



FIRE DETECTION

VISION 2020P

CONVENTIONAL OPTICAL SMOKE DETECTOR

PRODUCT OVERVIEW

Features

- Low profile design
- Low current draw
- Automatic drift compensation
- Remote alarm trigger feature
- Easy maintenance
- Range of detector bases available
- Remote LED Option
- Approved to EN54-7:2000 (Amendment 1)



Description

The 2020P optical smoke detector is part of the Vision range of detectors. Vision is a range of conventional detectors, which have been produced using the latest in manufacturing technology and supplied with an array of installer-friendly advanced features, making them ideal for all your conventional fire detection requirements.

The 2020P optical smoke detector uses a state of the art optical chamber combined with an application specific integrated circuit (ASIC) to provide quick and accurate detection of fires. A combination of the unique chamber design and other technically advanced features will significantly extend the service intervals before cleaning of the detector becomes necessary.

A hand held laser tool can also be used in conjunction with the Vision range of detectors for triggering the Vision detector. With a range of several metres, the hand held unit provides an effortless way of remotely triggering the Vision detector.

The 2020P detector has an integral LED, which illuminates to provide a local alarm signal. This latches on, and remains illuminated until the detector is reset by a momentary power interruption. An optional remote LED annunciator may be used to repeat any alarm signal.

A variety of detector bases can be used with the 2020P detector, providing application flexibility and compatibility with a wide range of conventional fire alarm panels, including our SMS range. All bases are fitted with a shorting spring to permit circuit testing prior to fitting the detector and have a tamper resistant feature, which when activated prevents removal of the detector without the use of a tool.

Please note: the laser triggering tool does not negate the requirement to test the detector as specified in BS 5839 Pt 1:2002.



FIRE DETECTION

VISION 2020P

CONVENTIONAL OPTICAL SMOKE DETECTOR

TECHNICAL SPECIFICATION

ELECTRICAL

Operating Voltage Range	14 to 28VDC (Nominal 24VDC)
Typical Standby Current @ 25°C	45µA @ 24VDC
Maximum Alarm Current	70mA @ 28VDC

ENVIRONMENTAL

Application Temperature Range	-30°C to +70°C
Humidity	5 to 95% Relative Humidity (non-condensing)

MECHANICAL

Height	32.5mm (plus 9.5mm for standard base)
Diameter	102mm
Weight	75g (plus 45g for standard base)
Max Wire Gauge for Terminals	1.5mm ²
Colour	Approximates RAL9016
Material	ABS
Approvals	LPCB pending, CE pending

DIMENSIONS (mm)



PRODUCT RANGE

Bases

Standard Base – adds 9.5mm to detector height 2020B

Standard base with Schottky diode 2020BSD

Deep Base – adds 21mm to detector height 2020DB

Deep Base with Schottky diode 2020DBSD

Accessories

Laser Triggering Tool 2020LT

Other Detectors

Optical Heat Detector 2020PT

Rate of Rise Heat Detector 2020R

58°C Fixed Temperature Heat Detector 2020F

78°C Fixed Temperature Heat Detector 2020HF

NOTES

It is essential to ensure that only known compatible components are used in a fire detection system. If in doubt, always consult the fire control panel supplier/manufacturer.



FIRE DETECTION

VISION 2020PT

OPTICAL HEAT DETECTOR

PRODUCT OVERVIEW

Features

- Low profile design
- Low current draw
- Automatic drift compensation
- Remote alarm trigger feature
- Easy maintenance
- Range of detector bases available
- Remote LED Option
- Approved to EN54 – 7:2000 (Amendment 1)
- EN54 – 5:2000 (Amendment 1) Class A1R; CEA 4021



Description

The 2020PT multi-functional detector is part of the Vision range of detectors. Vision is a range of conventional detectors, which have been produced using the latest in manufacturing technology and supplied with an array of installer-friendly advanced features, making them ideal for all your conventional fire detection requirements.

The 2020PT multi-functional detector uses a state of the art optical chamber and heat element combined with sophisticated algorithms to provide quick and accurate detection of fires. The combination of optical and heat detection provides a faster response to 'real fire' situations, while at the same time reducing the risk of unwanted environmentally generated alarms.

A hand held laser tool can also be used in conjunction with the Vision range of detectors for triggering the Vision detector. With a range of several metres, the hand held unit provides an effortless way of remotely triggering the Vision detector.

The 2020PT detector also has an integral LED, which illuminates to provide a local alarm signal. This latches on, and remains illuminated until the detector is reset by a momentary power interruption. An optional remote LED annunciator may be used to repeat any alarm signal.

A variety of detector bases can be used with the Vision detector, providing application flexibility and compatibility with a wide range of conventional fire alarm panels, including our SMS range. All bases are fitted with a shorting spring to permit circuit testing prior to fitting the detector and have a tamper resistant feature, which when activated prevents removal of the detector without the use of a tool.

Please note: the laser triggering tool does not negate the requirement to test the detector as specified in BS 5839 Pt 1:2002.



FIRE DETECTION

VISION 2020PT

OPTICAL HEAT DETECTOR

TECHNICAL SPECIFICATION

ELECTRICAL

Operating Voltage Range	14 to 28VDC (Nominal 24VDC)
Typical Standby Current @ 25°C	60µA @ 24VDC
Maximum Alarm Current	70mA @ 28VDC

ENVIRONMENTAL

Application Temperature Range (see note 1)	-30°C to +70°C
Humidity	5 to 95% Relative Humidity (non-condensing)

MECHANICAL

Height	40.5mm (plus 9.5mm for standard base)
Diameter	102mm
Weight	78g (plus 45g for standard base)
Max Wire Gauge for Terminals	1.5mm ²
Colour	Approximates RAL9016
Material	ABS
Approvals	LPCB pending, CE pending

DIMENSIONS (mm)

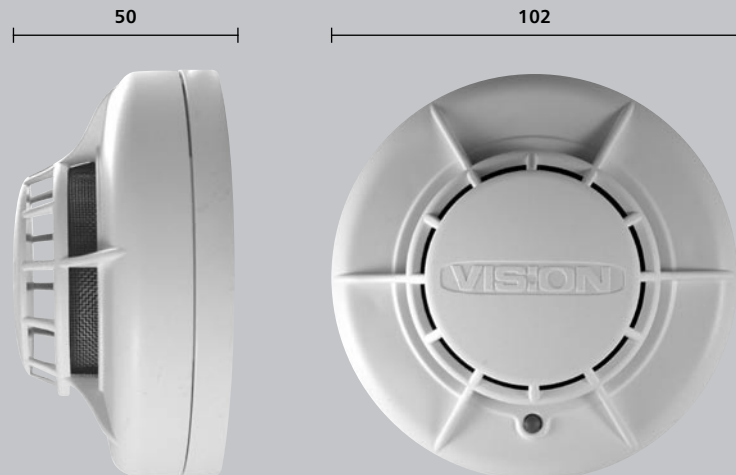

PRODUCT RANGE

Bases

Standard Base – adds 9.5mm to detector height	2020B
Standard base with Schottky diode	2020BSD
Deep Base – adds 21mm to detector height	2020DB
Deep Base with Schottky diode	2020DBSD

Accessories

Laser Triggering Tool	2020LT
-----------------------	--------

Other Detectors

Optical Detector	2020P
Rate of Rise Heat Detector	2020R
58°C Fixed Temperature Heat Detector	2020F
78°C Fixed Temperature Heat Detector	2020HF

NOTES

1. To avoid unwanted alarm conditions being triggered by class A1R detectors, the maximum ambient operating temperature should not exceed 45°C.

2. It is essential to ensure that only known compatible components are used in a fire detection system. If in doubt, always consult the fire control panel supplier/manufacturer.



FIRE DETECTION

VISION 2020R

RATE OF RISE HEAT DETECTOR

PRODUCT OVERVIEW

Features

- Low profile design
- Low current draw
- Remote alarm trigger feature
- Easy maintenance
- Range of detector bases available
- Remote LED Option
- Approved to EN54 – 5:2000 (Amendment 1) Class A1R



Description

The 2020R rate of rise heat detector is part of the Vision range of detectors. Vision is a range of conventional detectors, which have been produced using the latest in manufacturing technology and supplied with an array of installer-friendly advanced features, making them ideal for all your conventional fire detection requirements.

The 2020R heat detector uses a state of the art heat element combined with an application specific integrated circuit (ASIC) to provide quick and accurate detection of fires. The detector incorporates both rate of rise and static elements and is suitable for all areas where the ambient conditions do not normally exhibit rapid changes in temperature.

A hand held laser tool can also be used in conjunction with the Vision range of detectors for triggering the Vision detector. With a range of several metres, the hand held unit provides an effortless way of remotely triggering the Vision detector.

The 2020R detector also has an integral LED, which illuminates to provide a local alarm signal. This latches on, and remains illuminated until the detector is reset by a momentary power interruption. An optional remote LED annunciator may be used to repeat any alarm signal.

A variety of detector bases can be used with the 2020R detector, providing application flexibility and compatibility with a wide range of conventional fire alarm panels, including our SMS range. All bases are fitted with a shorting spring to permit circuit testing prior to fitting the detector and have a tamper resistant feature, which when activated prevents removal of the detector without the use of a tool.

Please note: the laser triggering tool does not negate the requirement to test the detector as specified in BS 5839 Pt 1:2002.



FIRE DETECTION

VISION 2020R

RATE OF RISE HEAT DETECTOR

TECHNICAL SPECIFICATION

ELECTRICAL

Operating Voltage Range	14 to 28VDC (Nominal 24VDC)
Typical Standby Current @ 25°C	55µA @ 24VDC
Maximum Alarm Current	70mA @ 28VDC

ENVIRONMENTAL

Application Temperature Range (see note 1)	-30°C to +70°C
Humidity	5 to 95% Relative Humidity (non-condensing)

MECHANICAL

Height	40.5mm (plus 9.5mm for standard base)
Diameter	102mm
Weight	70g (plus 45g for standard base)
Max Wire Gauge for Terminals	1.5mm ²
Colour	Approximates RAL9016
Material	ABS
Approvals	LPCB pending, CE pending

DIMENSIONS (mm)

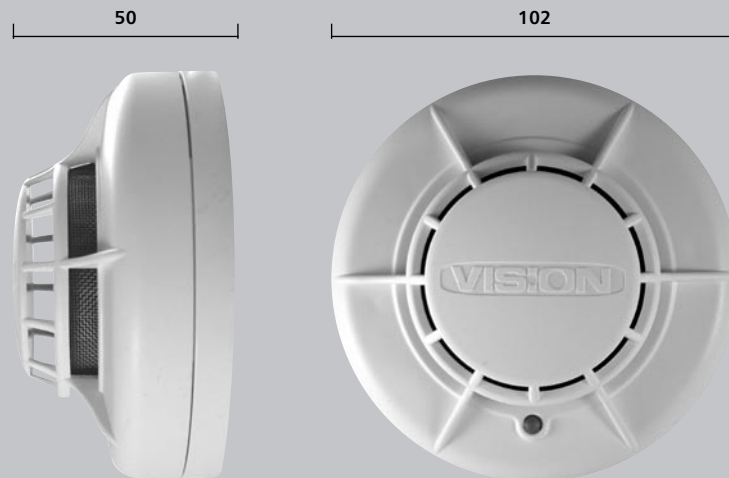

PRODUCT RANGE

Bases

Standard Base – adds 9.5mm to detector height	2020B
Standard base with Schottky diode	2020BSD
Deep Base – adds 21mm to detector height	2020DB
Deep Base with Schottky diode	2020DBSD

Accessories

Laser Triggering Tool	2020LT
-----------------------	--------

Other Detectors

Optical Heat Detector	2020PT
Optical Detector	2020P
58°C Fixed Temperature Heat Detector	2020F
78°C Fixed Temperature Heat Detector	2020HF

NOTES

1. To avoid unwanted alarm conditions being triggered by class A1R detectors, the maximum ambient operating temperature should not exceed 45°C.

2. It is essential to ensure that only known compatible components are used in a fire detection system. If in doubt, always consult the fire control panel supplier/manufacturer.



FIRE DETECTION

VISION 2020F

58°C FIXED TEMPERATURE HEAT DETECTOR

PRODUCT OVERVIEW

Features

- Low profile design
- Low current draw
- Easy maintenance
- Range of detector bases available
- Remote LED Option
- Approved to EN54 – 5:2000 (Amendment 1) Class A2S
- Remote alarm trigger feature



Description

The 2020F 58°C fixed temperature heat detector is part of the Vision range of detectors. Vision is a range of conventional detectors, which have been produced using the latest in manufacturing technology and supplied with an array of installer-friendly advanced features, making them ideal for all your conventional fire detection requirements.

The 2020F 58°C fixed temperature heat detector uses a state of the art heat element combined with an application specific integrated circuit (ASIC) to provide quick and accurate detection of fires. The detector incorporates a static element and is suitable where ambient conditions normally exhibit rapid changes in temperature e.g. kitchens.

A hand held laser tool can also be used in conjunction with the Vision range of detectors for triggering the Vision detector. With a range of several metres, the hand held unit provides an effortless way of remotely triggering the Vision detector.

The 2020F detector also has an integral LED, which illuminates to provide a local alarm signal. This latches on, and remains illuminated until the detector is reset by a momentary power interruption. An optional remote LED annunciator may be used to repeat any alarm signal.

A variety of detector bases can be used with the 2020F detector, providing application flexibility and compatibility with a wide range of conventional fire alarm panels, including our SMS range. All bases are fitted with a shorting spring to permit circuit testing prior to fitting the detector and have a tamper resistant feature, which when activated prevents removal of the detector without the use of a tool.

Please note: the laser triggering tool does not negate the requirement to test the detector as specified in BS 5839 Pt 1:2002.



FIRE DETECTION

VISION 2020F

58°C FIXED TEMPERATURE HEAT DETECTOR

TECHNICAL SPECIFICATION

ELECTRICAL

Operating Voltage Range	14 to 28VDC (Nominal 24VDC)
Typical Standby Current @ 25°C	55µA @ 24VDC
Maximum Alarm Current	70mA @ 28VDC

ENVIRONMENTAL

Application Temperature Range (see note 1)	-30°C to +70°C
Humidity	5 to 95% Relative Humidity (non-condensing)

MECHANICAL

Height	40.5mm (plus 9.5mm for standard base)
Diameter	102mm
Weight	70g (plus 45g for standard base)
Max Wire Gauge for Terminals	1.5mm ²
Colour	Approximates RAL9016
Material	ABS
Approvals	LPCB pending, CE pending

DIMENSIONS (mm)

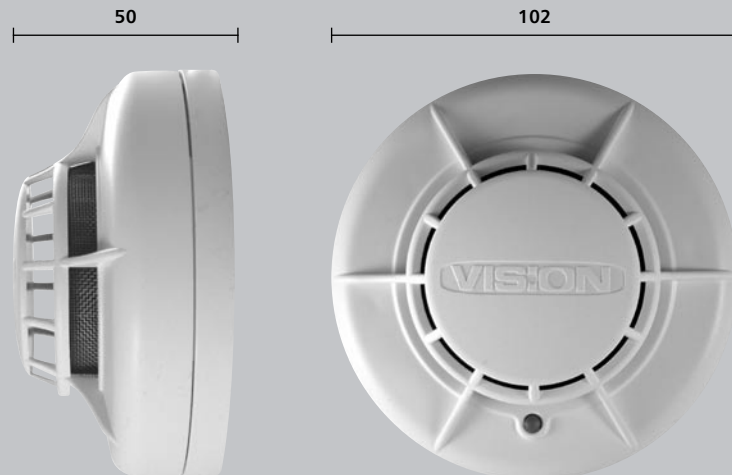

PRODUCT RANGE

Bases

Standard Base – adds 9.5mm to detector height	2020B
Deep Base – adds 21mm to detector height	2020DB
Standard base with Schottky diode	2020BSD
Deep Base with Schottky diode	2020DBSD

Accessories

Laser Triggering Tool	2020LT
-----------------------	--------

Other Detectors

Optical Heat Detector	2020PT
Optical Detector	2020P
Rate of Rise Heat Detector	2020R
78°C Fixed Temperature Heat Detector	2020HF

NOTES

1. To avoid unwanted alarm conditions being triggered by class A2S detectors the maximum ambient operating temperature should not exceed 45°C.

2. It is essential to ensure that only known compatible components are used in a fire detection system. If in doubt, always consult the fire control panel supplier/manufacturer.



FIRE DETECTION

VISION 2020HF

78°C FIXED TEMPERATURE HEAT DETECTOR

PRODUCT OVERVIEW

Features

- Low profile design
- Low current draw
- Easy maintenance
- Range of detector bases available
- Remote LED Option
- Approved to EN54 – 5:2000 (Amendment 1) Class BS
- Remote alarm trigger feature



Description

The 2020HF 78°C fixed temperature heat detector is part of the Vision range of detectors. Vision is a range of conventional detectors, which have been produced using the latest in manufacturing technology and supplied with an array of installer-friendly advanced features, making them ideal for all your conventional fire detection requirements.

The 2020HF 78°C fixed temperature heat detector uses a state of the art heat element combined with an application specific integrated circuit (ASIC) to provide quick and accurate detection of fires. The detector incorporates a static element and is suitable where ambient conditions normally exhibit rapid changes in temperature above 45°C e.g. boiler houses.

A hand held laser tool can also be used in conjunction with the Vision range of detectors for triggering the Vision detector. With a range of several metres, the hand held unit provides an effortless way of remotely triggering the Vision detector.

The 2020HF detector also has an integral LED, which illuminates to provide a local alarm signal. This latches on, and remains illuminated until the detector is reset by a momentary power interruption. An optional remote LED annunciator may be used to repeat any alarm signal.

A variety of detector bases can be used with the 2020HF detector, providing application flexibility and compatibility with a wide range of conventional fire alarm panels, including our SMS range. All bases are fitted with a shorting spring to permit circuit testing prior to fitting the detector and have a tamper resistant feature, which when activated prevents removal of the detector without the use of a tool.

Please note: the laser triggering tool does not negate the requirement to test the detector as specified in BS 5839 Pt 1:2002.



FIRE DETECTION

VISION 2020HF

78°C FIXED TEMPERATURE HEAT DETECTOR

TECHNICAL SPECIFICATION

ELECTRICAL

Operating Voltage Range	14 to 28VDC (Nominal 24VDC)
Typical Standby Current @ 25°C	60µA @ 24VDC
Maximum Alarm Current	70mA

ENVIRONMENTAL

Application Temperature Range (see note 1)	-30°C to +70°C
Humidity	5 to 95% Relative Humidity (non-condensing)

MECHANICAL

Height	40.5mm (plus 9.5mm for standard base)
Diameter	102mm
Weight	70g (plus 45g for standard base)
Max Wire Gauge for Terminals	1.5mm ²
Colour	Approximates RAL9016
Material	ABS
Approvals	LPCB pending, CE pending

DIMENSIONS (mm)

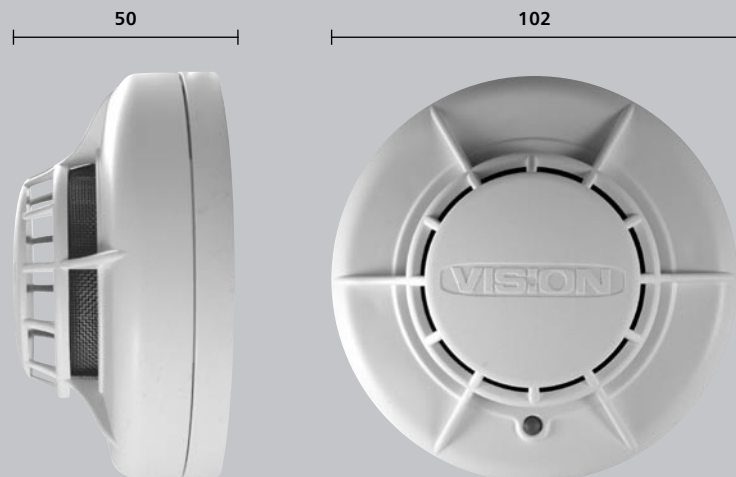

PRODUCT RANGE

Bases

Standard Base – adds 9.5mm to detector height 2020B

Standard base with Schottky diode 2020BSD

Deep Base – adds 21mm to detector height 2020DB

Deep Base with Schottky diode 2020DBSD

Accessories

Laser Triggering Tool 2020LT

Other Detectors

Optical Heat Detector 2020PT

Optical Detector 2020P

Rate of Rise Heat Detector 2020R

58°C Fixed Temperature Heat Detector 2020F

NOTES

1. To avoid unwanted alarm conditions being triggered by class BS detectors the maximum ambient operating temperature should not exceed 65°C.

2. It is essential to ensure that only known compatible components are used in a fire detection system. If in doubt, always consult the fire control panel supplier/manufacturer.