



全漢企業股份有限公司  
FSP TECHNOLOGY INC.

台灣桃園市建國東路22號  
No. 22, Jianguo East Road., Taoyuan City, Taiwan, R.O.C.  
TEL:+886-3-375-9888  
FAX:+886-3-375-6966

統一編號：84239055  
Website : www.FSP-group.com  
Email : sales@fsp-group.com.tw

# SPECIFICATION



FSP300-60GHS,(F22001)

Released Date:2009/10/12-16:27:33



全漢企業股份有限公司  
FSP TECHNOLOGY INC.

台灣 桃園市建國東路 22 號  
NO.22, Jianguo E. Rd., Taoyuan City, Taiwan, R.O.C.  
TEL:+886-3-375-9888 FAX:+886-3-375-6966

# SPECIFICATION

## **FSP300-60GHS(85)**

**(For FSP(GB) LTD)**

**9PA300CW01**

### **Main Feature:**

**Meet 80 Plus Bronze  
High Efficiency  
High Power Density  
Active PFC Circuit  
Full Range Input  
Small Size**

**OCT. 07, 2009**

**REV: 1.00**



全漢企業股份有限公司  
FSP TECHNOLOGY INC.

---

**MODEL: FSP300-60GHS(85)**

**Revision History**

<u>Rev</u>	<u>Description</u>	<u>Date</u>	<u>Author</u>
1.00	Initial	2009/10/07	

## **1. GENERAL DESCRIPTION AND SCOPE**

This is the specification of Model FSP300-60GHS(85); AC-line powered switching power supply with active PFC (Power Factor Correction) circuit, meet EN61000-3-2 and with Full Range Input features.

The specification below is intended to describe as detailedly as possible the functions and performance of the subject power supply. Any comment or additional requirements to this specification from our customers will be highly appreciated and treated as a new target for us to approach.

## **2. REFERENCE DOCUMENTS**

The subject power supply will meet the EMI requirements and obtain main safety approvals as following:

### **2.1. EMI REGULATORY**

### **2.2. SAFETY**

### 3. INPUT ELECTRICAL SPECIFICATIONS

#### 3.1. AC INPUT

Parameter	Min.	Nom. <sup>(1)</sup>	Max.	Unit
V <sub>in</sub> (115VAC)	90	115	132	VAC <sub>rms</sub>
V <sub>in</sub> (230VAC)	180	230	264	VAC <sub>rms</sub>
V <sub>in</sub> Frequency	47	--	63	HZ

◆ Nominal voltages for test purposes are considered to be within  $\pm 1.0V$  of nominal.

#### 3.2. INRUSH CURRENT

Maximum inrush current from power-on (with power on at any point on the AC sine) and including, but not limited to, three line cycles, shall be limited to a level below the surge rating of the input line cord, AC switch if present, bridge rectifier, fuse, and EMI filter components. Repetitive ON/OFF cycling of the AC input voltage should not damage the power supply or cause the input fuse to blow.

#### 3.3. INPUT LINE CURRENT & POWER FACTOR (P.F.)

(At Full load)

AC input	Input line current	P.F.@ Full Load	P.F.@ Pin=75W
115V	< 3.5 Amps – rms	> 0.95	> 0.8
230V	< 2.0 Amps – rms	> 0.9	> 0.65

#### 3.4. EFFICIENCY

##### 3.4.1 General

Under the load conditions defined in Table 1. and Table 2. The loading condition for testing efficiency shown in Table 1 represents a fully loaded system. ~ 50% (typical) loaded system. and ~ 20% (light) loaded system.

**Table 1. Loading Table for Efficiency Measurements**

<b>300W(loading shown in Amps)</b>						
<b>Loading</b>	<b>+12V1</b>	<b>+12V2</b>	<b>+5V</b>	<b>+3.3V</b>	<b>-12V</b>	<b>+5Vsb</b>
<b>Full</b>	<b>8.72</b>	<b>9.97</b>	<b>7.58</b>	<b>7.96</b>	<b>0.31</b>	<b>1.56</b>
<b>Typical</b>	<b>4.36</b>	<b>4.98</b>	<b>3.79</b>	<b>3.98</b>	<b>0.16</b>	<b>0.78</b>
<b>Light</b>	<b>1.74</b>	<b>1.99</b>	<b>1.52</b>	<b>1.59</b>	<b>0.06</b>	<b>0.31</b>

**Table 2. Minimum Efficiency Vs Load**

<b>Loading</b>	<b>Voltage</b>	<b>Full load</b>	<b>Typical load</b>	<b>Light load</b>
<b>Required Minimum Efficiency</b>	<b>115V</b>	<b>82%</b>	<b>85%</b>	<b>82%</b>
<b>Required Minimum Efficiency</b>	<b>230V</b>	<b>82%</b>	<b>85%</b>	<b>82%</b>

◆ **Minimum Efficiency for test purposes are considered to be within  $\pm 1.0\%$  of nominal.**

#### **4 . OUTPUT ELECTRICAL REQUIREMENTS**

##### **4.1. OUTPUT VOLTAGE AND CURRENT RATING**

<b>Output</b>	<b>MINIMUM LOAD</b>	<b>NORMAL LOAD</b>	<b>MAXIMUM LOAD</b>	<b>PEAK LOAD</b>	<b>LOAD REG</b>	<b>LINE REG.</b>	<b>RIPPLE &amp; NOISE</b>
+3.3V	0.1A	10.5A	21A		$\pm 5\%$	$\pm 1\%$	70mV P-P
+5V	0.2A	10A	20A		$\pm 5\%$	$\pm 1\%$	70mV P-P
+12V1	0.1A	7A	14A		$\pm 5\%$	$\pm 1\%$	140mV P-P
+12V2	0.5A	8A	16A	19A	$\pm 5\%$	$\pm 1\%$	140mV P-P
-12V	0A	0.25A	0.5A		$\pm 10\%$	$\pm 1\%$	140mV P-P
+5VSB	0A	1.25A	2.5A	3A	$\pm 5\%$	$\pm 1\%$	70mV P-P

- ( 1 ) +3.3V & 5V total output not exceed 103W.
- ( 2 ) Total output continuous shall not exceed 300W watts.
- ( 3 ) +12V2 peak current is 19A(less then 10m sec.) , minimum voltage during peak is  $> 10.8V_{dc}$ .
- ( 4 ) +5Vsb peak current is 3A(less then 500m sec.) , minimum voltage during peak is  $> 4.5V_{dc}$ .
- ( 5 ) Voltages and ripple are measured at the load side of mating connectors with a 0.1 uF monolithic ceramic capacitor paralleled by a 10 uF electrolytic capacitor across the measuring terminals.

## 4.2. LOAD CAPACITY SPECIFICATIONS

The cross regulation defined as follows, the voltage regulation limits DC include DC Output ripple & noise.

LOAD	+3.3V	+5V	+12V1	+12V2	-12V	+5VSB
condition_1	X	X	X	X	X	2.5A
condition_2	0.1A	1.5A	0.1A	0.5A	0A	0A
condition_3	1.5A	0.2A	0.1A	0.5A	0.5A	0A
condition_4	1 A	10A	1A	16A	0.1A	0.1A
condition_5	1 A	2A	14A	1A	0.1A	0.1A
condition_6	1 A	14A	2A	2A	0.1A	0.1A
condition_7	0.9A	20A	7.85A	7.85A	0.3A	1A
condition_8	18A	2A	1A	1A	0A	0.1A
condition_9	21A	6.74A	7.85A	7.85A	0.3A	1A

## 4.3. HOLD-UP TIME (@80% of Full load of Table 1.)

115V / 60Hz : 17 m sec. minimum.

230V / 50Hz : 17 m sec. minimum.

The output voltage will remain within specification, in the event that the input power is removed or interrupted, for the duration of one cycle of the input frequency. The interruption may occur at any point in the AC voltage cycle. The power good signal shall remain high during this test.

#### 4.4. OUTPUT RISE TIME

(10% TO 95% OF FINAL OUTPUT VALUE, @FULL LOAD)

115V-rms or 230V-rms      + 3.3Vdc : 20ms Maximum  
    + 5Vdc : 20ms Maximum  
    + 12Vdc : 20ms Maximum  
    + 5Vsb : 20ms Maximum  
    - 12Vdc : 20ms Maximum

#### 4.5. OVER VOLTAGE PROTECTION

voltage source	protection point
+3.3V	3.76V-4.8V
+5V	5.6V-7.0V
+12V	13.0V-16.5V

#### 4.6. OVER CURRENT PROTECTION

output voltage	max. over current limit
+3.3V	60A
+5V	48A
+12V1	30A
+12V2	30A

#### 4.7. SHORT CIRCUIT PROTECTION

Output short circuit is defined to be a short circuit load of less than 0.1 ohm.

In the event of an output short circuit condition on +3.3V, +5V, +12V or -12V output, the power supply will shutdown and latch off without damage to the power supply. The power supply shall return to normal operation after the short circuit has been removed and the power switch has been turned off for no more than 2 seconds.

#### 4.8. POWER SIGNAL

POWER GOOD @115/230V,FULL LOAD	100 –500m sec.
POWER FAIL @115/230V,FULL LOAD	1m sec. minimum

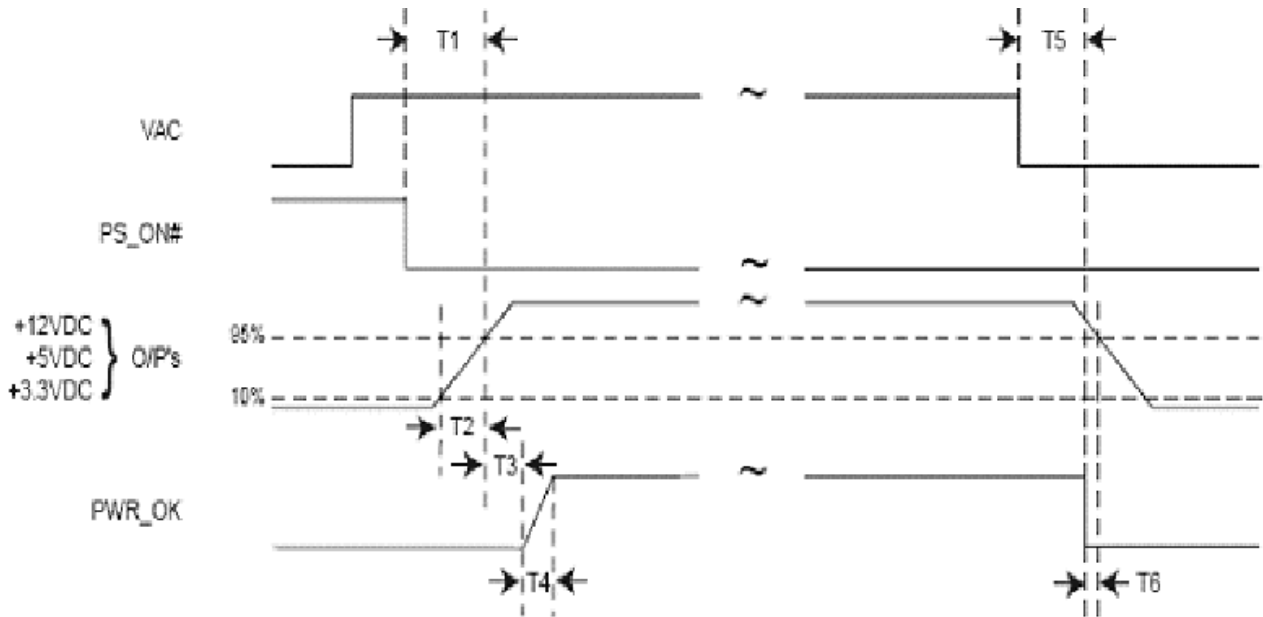

Figure:

- T1: Power-on time shall be less than 500 ms ( $T1 < 500 \text{ ms}$ ).
- T2: Rise time : 0.1 ms to 20 ms ( $0.1 \text{ ms} \leq T2 \leq 20 \text{ ms}$ ).
- T3: Power-ok delay time:  $100 \text{ ms} < T3 < 500 \text{ ms}$
- T4: Power-ok rise time:  $T4 \leq 1 \text{ ms}$
- T5 + T6: AC loss to output hold-up time :  $T5 + T6 \geq 17 \text{ ms}$

#### 5. FAN NOISE REQUIREMENTS

5.1.The subject power supply is cooled by a self-contained, 80mm×15mm, 12VDC fan.

#### 6. ENVIRONMENTAL REQUIREMENTS

The power supply will be compliant with each item in this specification for the following Environmental conditions.

##### 6.1. TEMPERATURE RANGE

Operating	+10 to +50 deg. C
Storage	-20 to +80 deg. C

The maximum continuous power rating of supply is 300W at 50°C.

## 6.2. HUMIDITY

Operating	5 –95% RH, Non-condensing
Storage	5 –95% RH, Non-condensing

## 6.3. VIBRATION

The subject power supply will withstand the following imposed conditions without experiencing non-recoverable failure or deviation from specified output characteristics.

Vibration Operating – Sine wave excited, 0.25 G maximum acceleration, 10-250 Hz swept at one octave / min. Fifteen minute dwell at all resonant points, where resonance is defined as those exciting frequencies at which the device under test experiences excursions two times large than non-resonant excursions.

Plane of vibration to be along three mutually perpendicular axes.

## 6.4. GROUND LEAKAGE CURRENT

The power supply ground leakage current shall be less than 3.5 mA.

## 6.5. RELIABILITY

The power supply reliability, when calculated by MIL-HDBK-217;latest revision, are exceed 100,000 hours with all output at Typical load and an ambient temperature of 25°C.

## 6.6. DIELECTRIC STRENGTH

Primary to Frame Ground : 1800 Vac for 1 sec.

Primary to Secondary : 1800Vac for 1 sec

## 6.7. INSULATION RESISTANCE

Primary to Frame Ground : 20 Meg.ohms Minimum

Primary to Secondary : 20 Meg.ohms Minimum

## **7. LABELLING**

Label marking will be permanent, legible and complied with all agency requirements.

### **7.1. MODEL NUMBER LABEL**

Labels will be affixed to the sides of the power supply showing the following:

- Manufacturer's name and logo.
- Model no., serial no., revision level, location of manufacturer.
- The total power output and the maximum load for each output.
- AC input rating.

## **8. MECHANICAL SPECIFICATIONS**

The mechanical drawing of the subject power supply, which indicate the form factor, location of the mounting holes, location, the length of the connectors, and other physical specifications of the subject power supply. Please refer to the attachment drawing.