

# Modular Type Lubricator *Series AL*

## Lubricator Series AL



Pages 50 through 54

Model	Port size	Accessory
<b>AL10</b>	M5 x 0.8	Bracket
<b>AL20</b>	1/8, 1/4	
<b>AL30</b>	1/4, 3/8	
<b>AL40</b>	1/4, 3/8, 1/2	
<b>AL40-06</b>	3/4	
<b>AL50</b>	3/4, 1	
<b>AL60</b>	1	

# Lubricator

# AL10 to 60

## How to Order

AL 30 - F 03 B - 2R

Lubricator

Body size

10 20 30 40 50 60

Thread type

Nil	Metric thread (M5)
	Rc
N	NPT
F	G

Port size

Symbol	Port size	Body size					
		10	20	30	40	50	60
M5	M5	●	—	—	—	—	—
01	1/8	—	●	—	—	—	—
02	1/4	—	●	●	—	—	—
03	3/8	—	—	●	●	—	—
04	1/2	—	—	—	—	—	—
06	3/4	—	—	—	—	●	—
10	1	—	—	—	—	●	●

Optional specifications

Symbol	Description	Applicable model
1	1000cm <sup>3</sup> tank	AL30 to 60
10	1000cm <sup>3</sup> tank with level switch (lowest limit ON)	AL30 to 60
11	1000cm <sup>3</sup> tank with level switch (lowest limit OFF)	AL30 to 60
2	Metal bowl	AL10 to 60
3	With drain cock	AL10 to 60
6	Nylon bowl (including sight dome)	AL10 to 60
8	Metal bowl with level gauge	AL30 to 60
C	With bowl guard	AL20
R	Flow direction: Right to left	AL10 to 60
3W	Drain cock with barb fitting: ø6 x ø4 nylon tubing	AL30 to 60
Z <sup>Note 2)</sup>	Name plate and caution plate for bowl in imperial units (PSI, °F)	AL10 to 60

Accessory \* When more than one specification is required, indicate in alphanumeric order.

Symbol	Description	Applicable model
Nil	—	—
B <sup>Note 1)</sup>	With bracket	AL20 to AL 60

Note 2) For M5 and NPT thread types. This product is for overseas use only according to the new Measurement Law. (The SI unit type is provided for use in Japan.)

Note 1) Bracket is not assembled and is supplied loose at the time of shipment.

⊙ : Combination available

□ : Combination not available

○ : Varies depending on the model

△ : Available only with NPT thread

### Accessory/Optional specification combinations

Accessory/Optional specifications	Combination	Symbol	Accessory	Optional specification											Applicable lubricator						
				B	1	10	11	2	3	6	8	C	R	3W	Z	AL10	AL20	AL30 to 60			
Accessory	With bracket	B		○	○	○	○	○	○	○	○	○	○	○	○	○	○	○	○		
Optional specifications	1000cm <sup>3</sup> tank	-1	⊙																⊙		
	1000cm <sup>3</sup> tank with level switch (lowest limit ON)	-10	⊙																	⊙	
	1000cm <sup>3</sup> tank with level switch (lowest limit OFF)	-11	⊙																	⊙	
	Metal bowl	-2	⊙																	⊙	
	With drain cock	-3	⊙					⊙												⊙	
	Nylon bowl (including sight dome)	-6	⊙																	⊙	
	Metal bowl with level gauge	-8	⊙																		⊙
	With bowl guard	-C	⊙																		⊙
	Flow direction: Right to left	-R	⊙		⊙	⊙	⊙	⊙	⊙	⊙	⊙	⊙	⊙	⊙	⊙	⊙	⊙	⊙	⊙	⊙	⊙
	Drain cock with barb fitting: ø6 x ø4 nylon tubing	-3W	⊙																		⊙
Name plate and caution plate for bowl in imperial units (PSI, °F)	-Z	△	△	△	△	△	△	△	△	△	△	△	△	△	△	△	△	△	△	△	

Note) -1, -10, -11 are for a metal bowl with level gauge that comes with drain cock.



AL20



AL40

JIS symbol

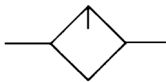

### Standard specifications

Model	AL10	AL20	AL30	AL40	AL40-06	AL50	AL60
Port sizes	M5 x 0.8	1/8, 1/4	1/4, 3/8	1/4, 3/8, 1/2	3/4	3/4, 1	1
Fluid	Air						
Proof pressure	1.5MPa						
Maximum operating pressure	1.0MPa						
Minimum dripping flow rate [L/min (ANR)] <sup>Note 1)</sup>	4	15	1/4: 30 3/8: 40	1/4: 30 3/8: 40 1/2: 50	50	190	220
Oil capacity (cm <sup>3</sup> )	7	25	55	135	135	135	135
Recommended lubricant	Class 1 turbine oil (ISO VG32)						
Ambient and fluid temperature	-5 to 60°C (with no freezing)						
Bowl material	Polycarbonate						
Bowl guard	—	Option	Standard				
Weight (kg)	0.07	0.20	0.24	0.47	0.52	1.06	1.13



Notes 1) • The flow rate is 5 drips/min under the following conditions: Inlet pressure of 0.5MPa; Class 1 turbine oil (ISO VG32); Temperature at 20°C; Oil adjustment valve fully open.

• Use air consumption flow rate for minimum dripping flow rate.

### Accessory part no.

Accessory	Applicable model	AL10	AL20	AL30	AL40	AL40-06	AL50	AL60
Bracket assembly <sup>Note)</sup>		—	AF20P-050AS	AF30P-050AS	AF40P-050AS	AF40P-070AS	AF50P-050AS	AF50P-050AS



\* The part number for Bracket assembly for 1000cm<sup>3</sup> is AF50P-050AS (applicable to AL30 to AL60).

Note) Assembly includes a bracket and 2 mounting screws.

# AL10 to 60

## Flow Characteristics (Representative values)

Condition: Inlet pressure 0.7MPa

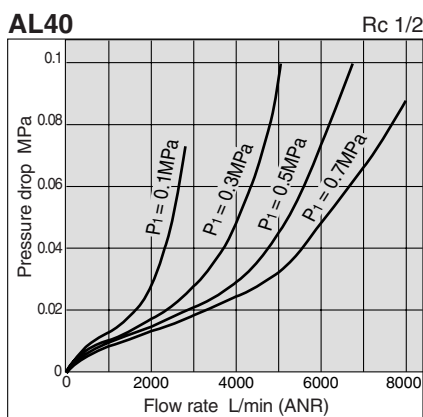
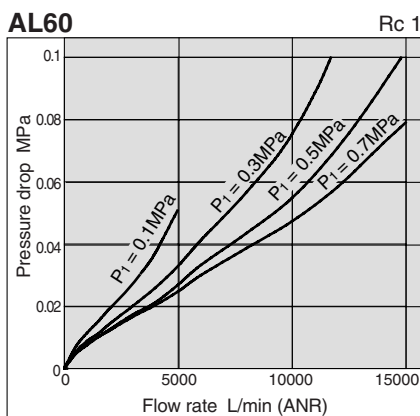
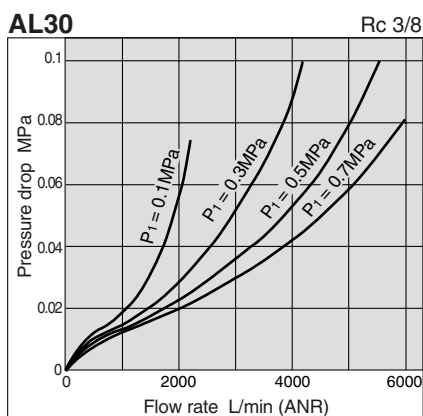
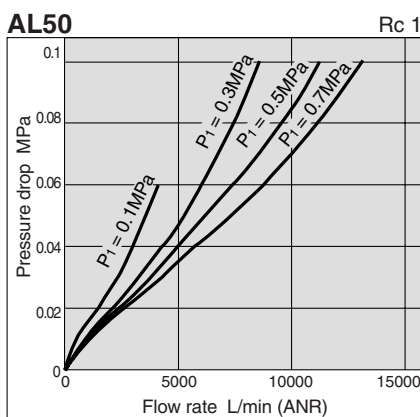
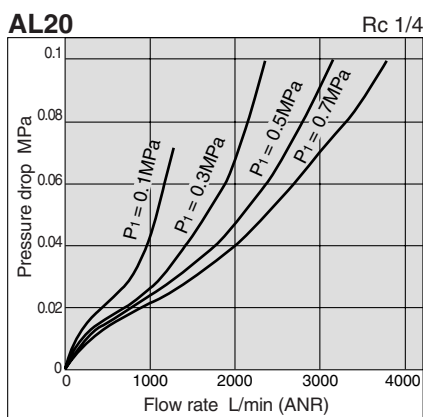
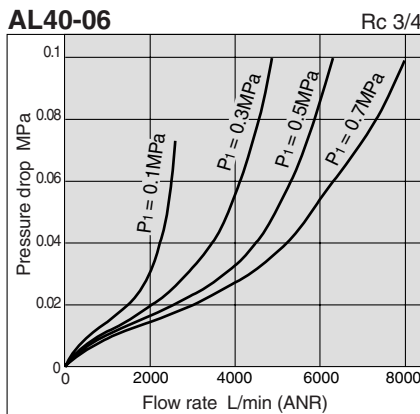
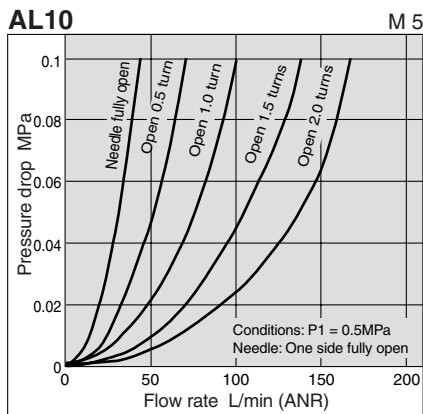

## Operating Principle: AL10 Type

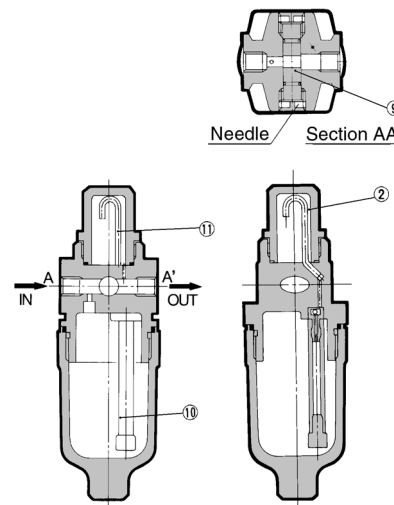

A portion of the air introduced from the IN side pressurizes the lubricant inside the bowl. The remainder of the air passes through the needles ⑨, and flows to the OUT side. The pressure differential between the inside of the bowl and the inside of the sight dome ②, causes the lubricant inside the bowl into the oil passage ⑩. The lubricant drips from the dripping tube ⑪, and lubricate the OUT side. The amount of lubricant is adjusted by the needle ⑨, on the front face. Turning the needle clockwise increases the amount of the lubricant, and turning it counterclockwise until fully opened shuts off the lubricant. The needle on the side that is not used should be left fully opened.

Note) The operating principle for AL20 to 60 types is different from that of AL10 type.

### ⚠ Specific Product Precautions

Be sure to read before handling. Refer to pages 75 through 78 for safety instructions and F.R.L. unit precautions.

### Selection

### ⚠ Warning

1. Do not introduce air from the outlet side as this can damage the damper.

### ⚠ Caution

1. Use a check valve (series AKM) to prevent back flow of the lubricant when redirecting the air flow before the lubricator.

### Maintenance

### ⚠ Warning

1. For AL10 type, replenish the lubricant after releasing the inlet pressure. Lubrication cannot take place under a pressurized condition.

### ⚠ Caution

1. Check the dripping amount once a day. Drip failure can cause damage to the components that need lubrication.

**Construction**

JIS symbol



**AL10**

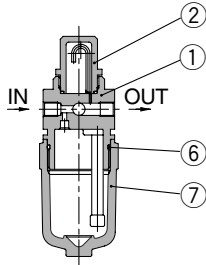

**AL20**

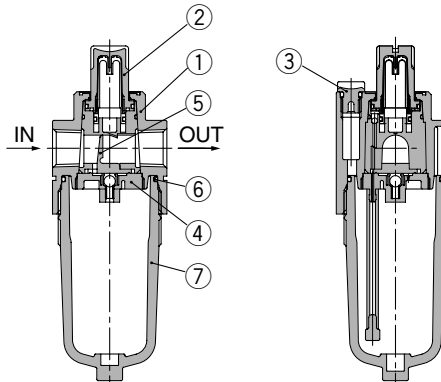

**AL30, 40**

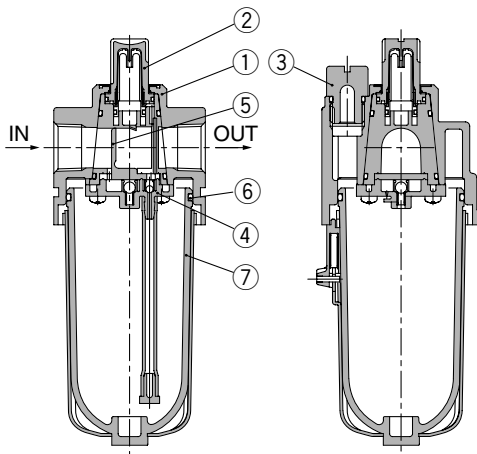

**AL50, 60**

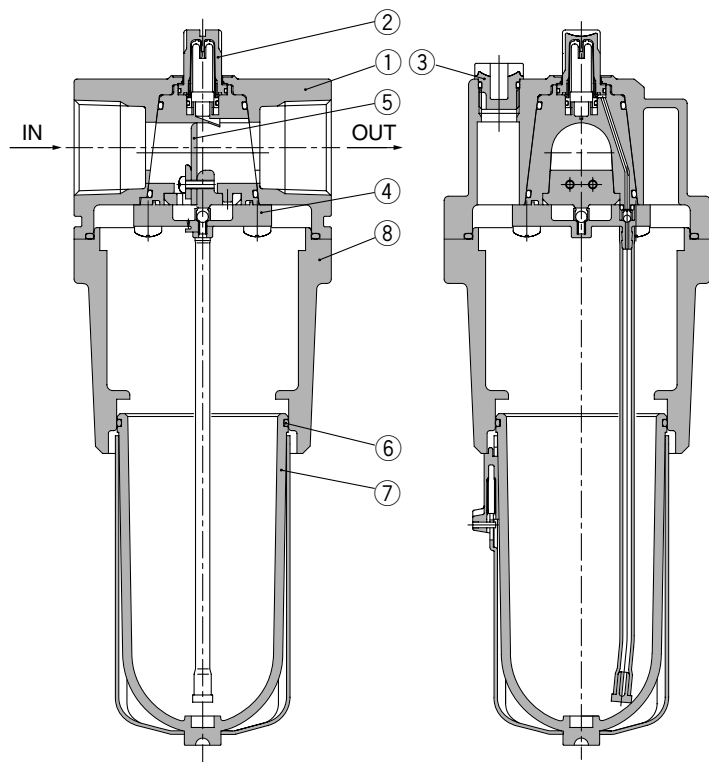

**Parts list**

No.	Description	Material			Note
		AL10, 20	AL30, 40, 40-06	AL50, 60	
1	Body	Zinc die-cast	Aluminum die-cast		Platinum silver
8	Housing	—		Aluminum die-cast	Platinum silver

**Replacement parts**

No.	Description	Material	Part no.						
			AL10	AL20	AL30	AL40	AL40-06	AL50	AL60
2	Sight dome assembly	PC	AL10P-080AS	AL20P-080AS	AL20P-080AS	AL20P-080AS	AL20P-080AS	AL20P-080AS	AL20P-080AS
3	Lubrication plug assembly	—	—	AL20P-060AS	AL30P-060AS	AL40P-060AS	AL40P-060AS	AL40P-060AS	AL40P-060AS
4	Damper retainer assembly <sup>Note 1)</sup>	—	—	AL20P-030AS	AL30P-030AS	AL40P-030AS	AL40P-030AS	AL50P-030AS	AL60P-030AS
5	Damper assembly	Synthetic resin	—	AL20P-040S	AL30P-040S	AL40P-040S	AL40P-040S	AL50P-040AS	AL60P-040AS
6	Bowl O-ring	NBR	C1SFP-260S	C2SFP-260S	C3SFP-260S	C4SFP-260S	C4SFP-260S	C4SFP-260S	C4SFP-260S
7	Bowl assembly <sup>Note 2)</sup>	PC	C1SL	C2SL	C3SL <sup>Note 3)</sup>	C4SL <sup>Note 3)</sup>	C4SL <sup>Note 3)</sup>	C4SL <sup>Note 3)</sup>	C4SL <sup>Note 3)</sup>

Note 1) Add "-1" at the end of the part number when ordering a damper retainer assembly for 1000cm<sup>3</sup>.  
Example) AL30P-030AS-1

Note 2) Including O-Ring. Contact P/A regarding the bowl assembly supply for PSI and °F unit specifications.

Note 3) Bowl assembly for AL30 to AL60 comes with a bowl guard (steel band material).

# AL10 to 60

## Dimensions

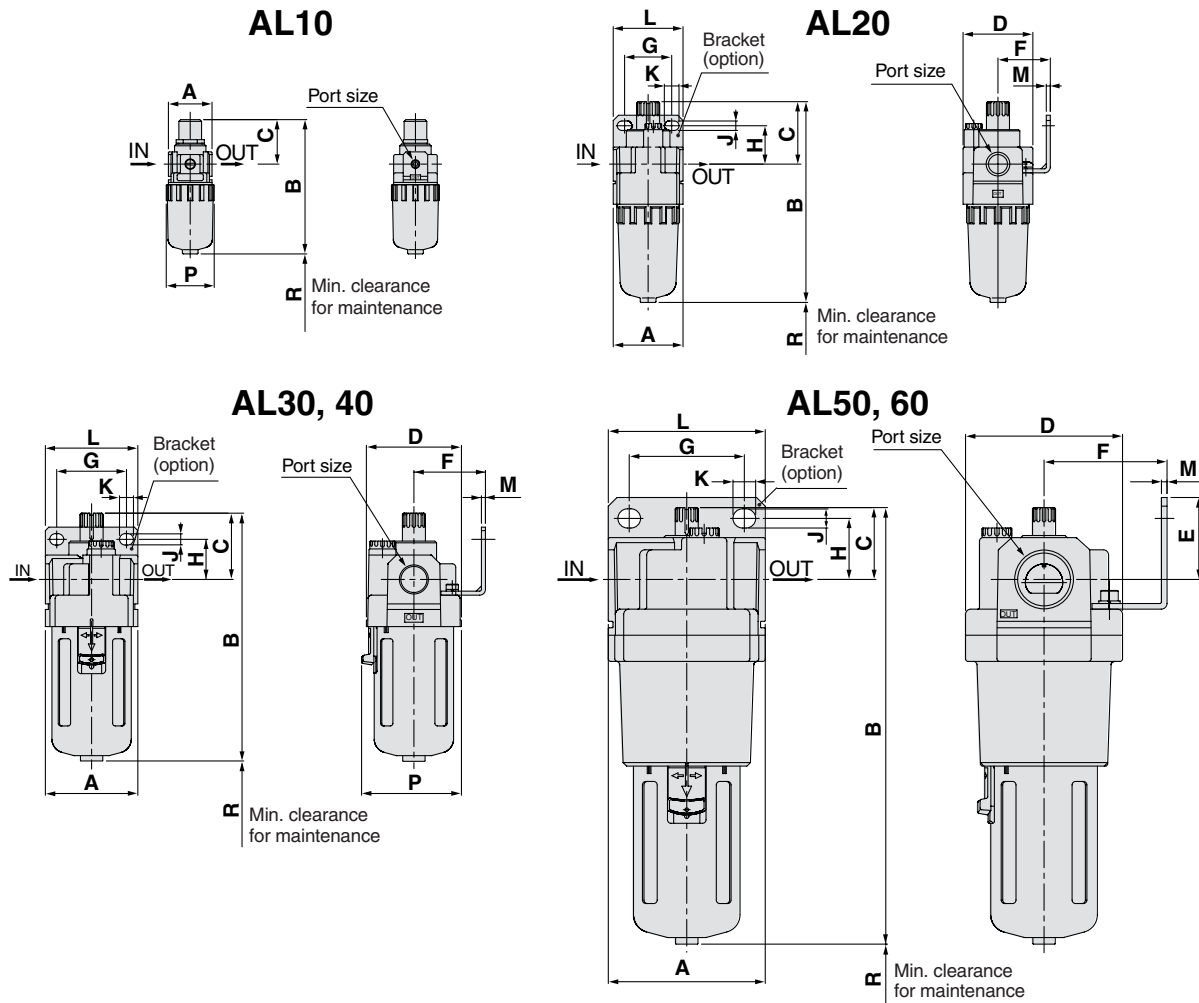

Applicable model	AL10, AL20				AL30, AL40, AL40-06, AL50, AL60				
Optional specifications	With drain cock	Metal bowl with drain cock	Metal bowl	With drain cock	Metal bowl with level gauge	Metal bowl with drain cock	Metal bowl with drain cock & level gauge	Drain cock with barb fitting	
									Barb fitting Applicable tubing: T0604

Model	Port size	Standard specification						Accessory specification							
		A	B	C	D	P	R	Bracket mounting size							
								E	F	G	H	J	K	L	M
AL10	M5 x 0.8	25	77	26	25	28	35	—	—	—	—	—	—	—	—
AL20	1/8, 1/4	40	115	36	40	—	60	—	30	27	22	5.4	8.4	40	2.3
AL30	1/4, 3/8	53	142	38	53	57	80	—	41	40	23	6.5	8	53	2.3
AL40	1/4, 3/8, 1/2	70	176	40	70	73	110	—	50	54	26	8.5	10.5	70	2.3
AL40-06	3/4	75	176	38	70	73	110	—	50	54	25	8.5	10.5	70	2.3
AL50	3/4, 1	90	250	41	90	—	110	47	70	66	35	11	13	90	3.2
AL60	1	95	268	45	95	—	110	47	70	66	35	11	13	90	3.2

Model	Optional specification					
	With drain cock	With barb fitting	Metal bowl	Metal bowl with drain cock	Metal bowl with level gauge	Metal bowl with drain cock & level gauge
	B	B	B	B	B	B
AL10	85	—	82	85	—	—
AL20	123	—	121	124	—	—
AL30	153	161	142	166	162	186
AL40	187	195	176	200	196	220
AL40-06	187	195	176	200	196	220
AL50	261	269	250	274	270	294
AL60	279	287	268	292	288	312

## Dimensions

### Optional specifications: 1000cm<sup>3</sup> tank

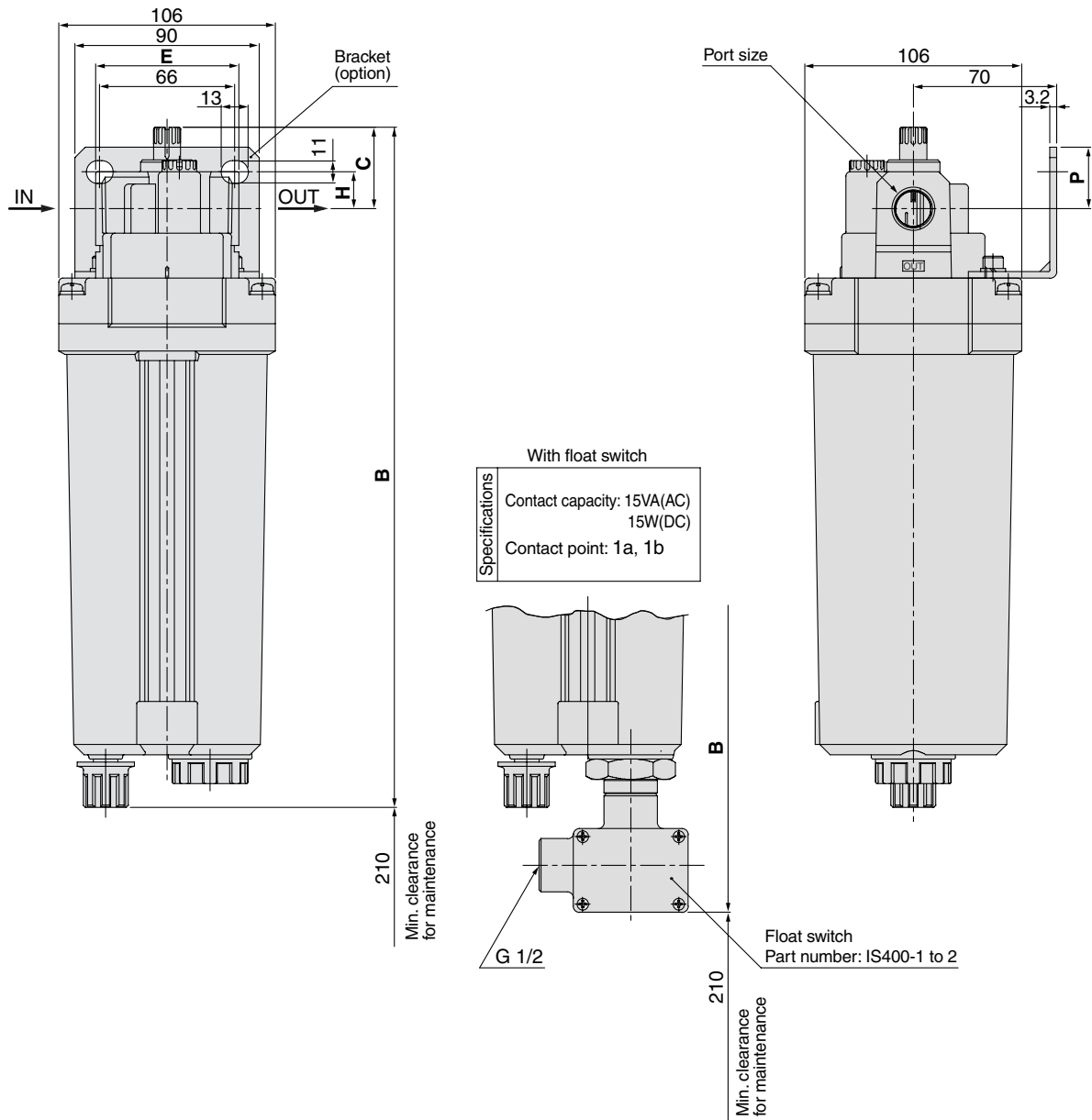

Model	Port size	B	C	E	With bracket		With float switch
					H	P	B
AL30	1/4, 3/8	324	38	53	25	—	374
AL40	1/4, 3/8, 1/2	333	40	70	18	—	383
AL40-06	3/4	333	38	75	16	—	383
AL50	3/4, 1	332	41	90	35	47	382
AL60	1	335	45	95	35	47	385