



FSA831 — USB2.0 High-Speed (480Mbps) Charger Detection with Isolation Switch

Features

USB Detection	USB Battery Charging Rev. 1.2 Supports Data Contact Detect (DCD) Dead Battery Provision (DBP) with 30-Minute Timer
Switch Type	Isolation Switch Closes for Charging Downstream Port (CDP) Standard Downstream Port (SDP)
V _{BUS}	28V Over-Voltage Tolerance -2V Under-Voltage Tolerance
Package	10-Lead MicroPak™ 1.6 x 2.1mm, 0.5mm Pitch
Ordering Information	FSA831L10X

Description

The FSA831 is a charger-detection IC with an integrated isolation switch for use with a micro/mini USB port. The FSA831 detects battery chargers and is compliant with USB Battery Charging Specification, Rev 1.2 (BC1.2). The algorithm incorporates Data Contact Detection (DCD), which ensures that the shorter, inner pins of the USB connector are making contact prior to continuing with battery charger detection. The device determines if a Dedicated Charging Port (DCP), Charging Downstream Port (CDP), or a typical PC host, called a Standard Downstream Port (SDP), is connected. If a charger is detected, the FSA831 determines whether the charger is a DCP or CDP. For SDP and CDP detection, an internal isolation switch is closed to connect the D+/D- lines of the USB cable to the resident USB transceiver within the portable device. The FSA831 conforms to all the constraints for the Dead Battery Provision (DBP) within the BC1.2 specification, including a 30-minute timer that cannot exceed 45 minutes, per BC1.2.

Applications

- MP3, Mobile Internet Device (MID), Cell Phone, PDA, Digital Camera, Notebook and Netbook

Related Resources

- For samples and questions, please contact: analogswitch@fairchildsemi.com.

Typical Application

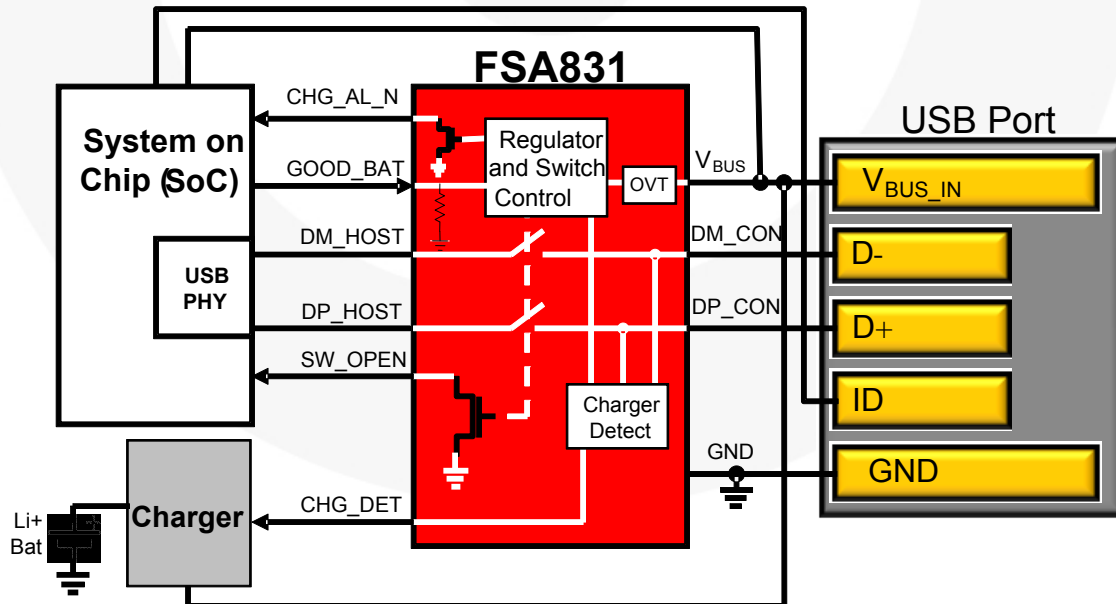

Figure 1. Mobile Phone Example

Physical Dimensions

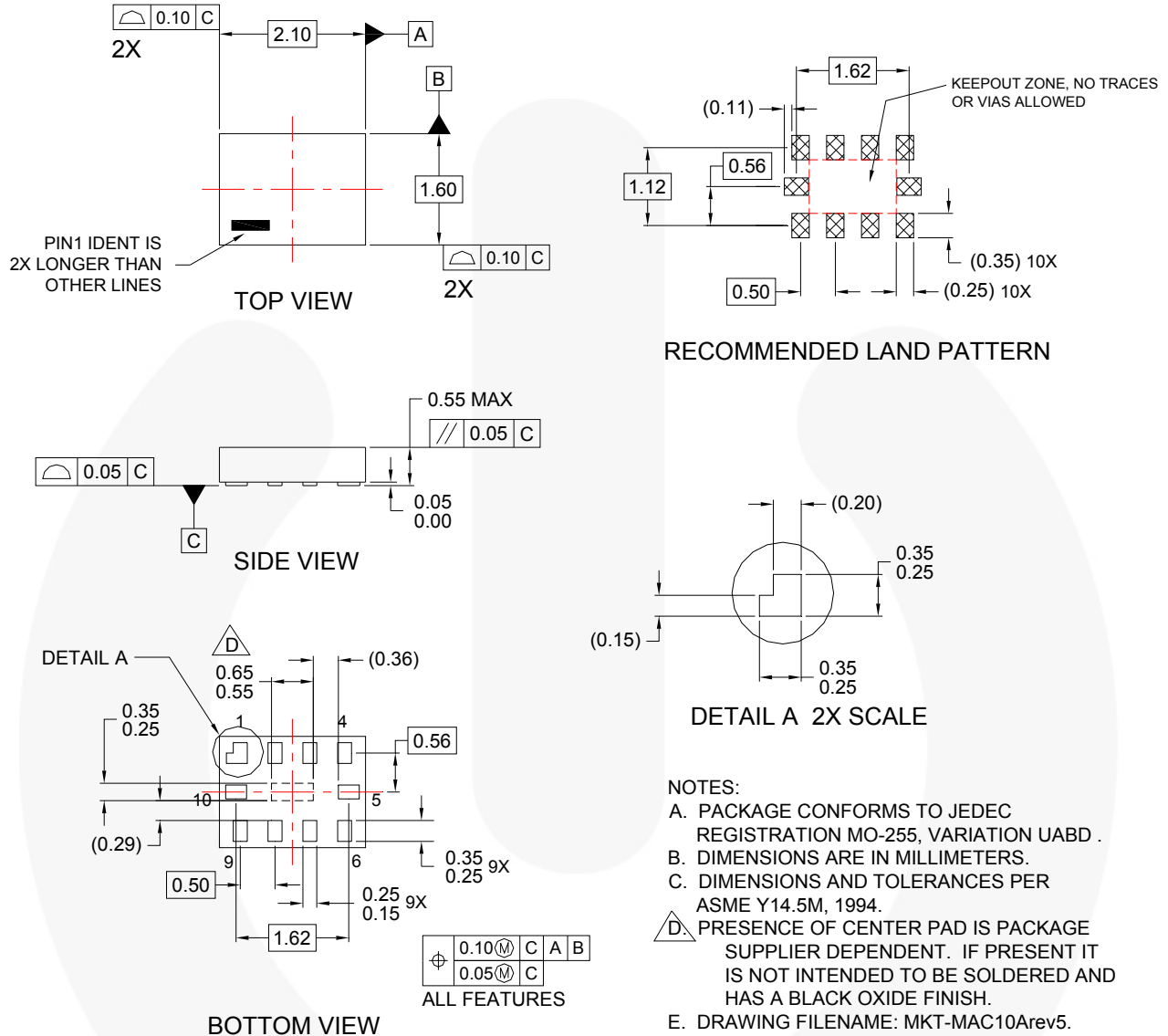

Figure 10. 10-Lead, MicroPak™

Part Number	Top Mark	Operating Temperature Range	Package Description	Packing Method
FSA831L10X	KY	-40 to 85°C	10-Lead, MicroPak™ 1.6 x 2.1mm, 0.5mm Pitch	Tape & Reel

Package drawings are provided as a service to customers considering Fairchild components. Drawings may change in any manner without notice. Please note the revision and/or date on the drawing and contact a Fairchild Semiconductor representative to verify or obtain the most recent revision. Package specifications do not expand the terms of Fairchild's worldwide terms and conditions, specifically the warranty therein, which covers Fairchild products.

Always visit Fairchild Semiconductor's online packaging area for the most recent package drawings:
<http://www.fairchildsemi.com/packaging/>



TRADEMARKS

The following includes registered and unregistered trademarks and service marks, owned by Fairchild Semiconductor and/or its global subsidiaries, and is not intended to be an exhaustive list of all such trademarks.

- | | | | |
|---|--|---|---|
| 2Cool™ | FlashWriter®* |  | The Power Franchise® |
| AccuPower™ | FPS™ | PowerTrench® | the power franchise |
| Auto-SPM™ | F-PFS™ | PowerXS™ | TinyBoost™ |
| AX-CAP™* | FRFET® | Programmable Active Droop™ | TinyBuck™ |
| BitSiC™ | Global Power Resource™ | QFET® | TinyCalc™ |
| Build it Now™ | Green FPS™ | QS™ | TinyLogic® |
| CorePLUS™ | Green FPS™ e-Series™ | Quiet Series™ | TINYOPTO™ |
| CorePOWER™ | Gmax™ | RapidConfigure™ | TinyPower™ |
| CROSSVOLT™ | GTO™ |  | TinyPWM™ |
| CTL™ | IntelliMAX™ | Saving our world, 1mW/W/kW at a time™ | TinyWire™ |
| Current Transfer Logic™ | ISOPLANAR™ | SignalWise™ | TranSiC™ |
| DEUXPEED® | Making Small Speakers Sound Louder and Better™ | SmartMax™ | TriFault Detect™ |
| Dual Cool™ | MegaBuck™ | SMART START™ | TRUECURRENT®* |
| EcoSPARK® | MICROCOUPLER™ | Solutions for Your Success™ | µSerDes™ |
| EfficientMax™ | MicroFET™ | SPM® |  |
| ESBC™ | MicroPak™ | STEALTH™ | UHC® |
|  | MicroPak2™ | SuperFET® | Ultra FRFET™ |
| Fairchild® | MillerDrive™ | SuperSOT™-3 | UniFET™ |
| Fairchild Semiconductor® | MotionMax™ | SuperSOT™-6 | Vcx™ |
| FACT Quiet Series™ | Motion-SPM™ | SuperSOT™-8 | VisualMax™ |
| FACT® | mWSaver™ | SupreMOS® | VoltagePlus™ |
| FAST® | OptoHiT™ | SyncFET™ | XS™ |
| FastvCore™ | OPTOLOGIC® | Sync-Lock™ | |
| FETBench™ | OPTOPLANAR® |  | |

* Trademarks of System General Corporation, used under license by Fairchild Semiconductor.

DISCLAIMER

FAIRCHILD SEMICONDUCTOR RESERVES THE RIGHT TO MAKE CHANGES WITHOUT FURTHER NOTICE TO ANY PRODUCTS HEREIN TO IMPROVE RELIABILITY, FUNCTION, OR DESIGN. FAIRCHILD DOES NOT ASSUME ANY LIABILITY ARISING OUT OF THE APPLICATION OR USE OF ANY PRODUCT OR CIRCUIT DESCRIBED HEREIN; NEITHER DOES IT CONVEY ANY LICENSE UNDER ITS PATENT RIGHTS, NOR THE RIGHTS OF OTHERS. THESE SPECIFICATIONS DO NOT EXPAND THE TERMS OF FAIRCHILD'S WORLDWIDE TERMS AND CONDITIONS, SPECIFICALLY THE WARRANTY THEREIN, WHICH COVERS THESE PRODUCTS.

LIFE SUPPORT POLICY

FAIRCHILD'S PRODUCTS ARE NOT AUTHORIZED FOR USE AS CRITICAL COMPONENTS IN LIFE SUPPORT DEVICES OR SYSTEMS WITHOUT THE EXPRESS WRITTEN APPROVAL OF FAIRCHILD SEMICONDUCTOR CORPORATION.

As used herein:

1. Life support devices or systems are devices or systems which, (a) are intended for surgical implant into the body or (b) support or sustain life, and (c) whose failure to perform when properly used in accordance with instructions for use provided in the labeling, can be reasonably expected to result in a significant injury of the user.
2. A critical component in any component of a life support, device, or system whose failure to perform can be reasonably expected to cause the failure of the life support device or system, or to affect its safety or effectiveness.

ANTI-COUNTERFEITING POLICY

Fairchild Semiconductor Corporation's Anti-Counterfeiting Policy. Fairchild's Anti-Counterfeiting Policy is also stated on our external website, www.fairchildsemi.com, under Sales Support.

Counterfeiting of semiconductor parts is a growing problem in the industry. All manufacturers of semiconductor products are experiencing counterfeiting of their parts. Customers who inadvertently purchase counterfeit parts experience many problems such as loss of brand reputation, substandard performance, failed applications, and increased cost of production and manufacturing delays. Fairchild is taking strong measures to protect ourselves and our customers from the proliferation of counterfeit parts. Fairchild strongly encourages customers to purchase Fairchild parts either directly from Fairchild or from Authorized Fairchild Distributors who are listed by country on our web page cited above. Products customers buy either from Fairchild directly or from Authorized Fairchild Distributors are genuine parts, have full traceability, meet Fairchild's quality standards for handling and storage and provide access to Fairchild's full range of up-to-date technical and product information. Fairchild and our Authorized Distributors will stand behind all warranties and will appropriately address any warranty issues that may arise. Fairchild will not provide any warranty coverage or other assistance for parts bought from Unauthorized Sources. Fairchild is committed to combat this global problem and encourage our customers to do their part in stopping this practice by buying direct or from authorized distributors.

PRODUCT STATUS DEFINITIONS

Definition of Terms

Datasheet Identification	Product Status	Definition
Advance Information	Formative / In Design	Datasheet contains the design specifications for product development. Specifications may change in any manner without notice.
Preliminary	First Production	Datasheet contains preliminary data; supplementary data will be published at a later date. Fairchild Semiconductor reserves the right to make changes at any time without notice to improve design.
No Identification Needed	Full Production	Datasheet contains final specifications. Fairchild Semiconductor reserves the right to make changes at any time without notice to improve the design.
Obsolete	Not In Production	Datasheet contains specifications on a product that is discontinued by Fairchild Semiconductor. The datasheet is for reference information only.

Rev. I59