

Verpackt in Gurtverpackung
Verpackungseinheit: 280 Stück

- Tape on Reel Packaging
- Packaging unit: 280 pcs

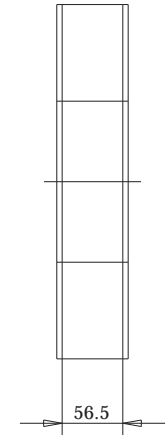

Abspulrichtung - Reel off Direction

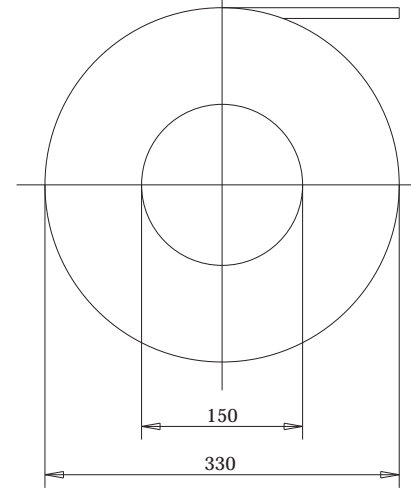
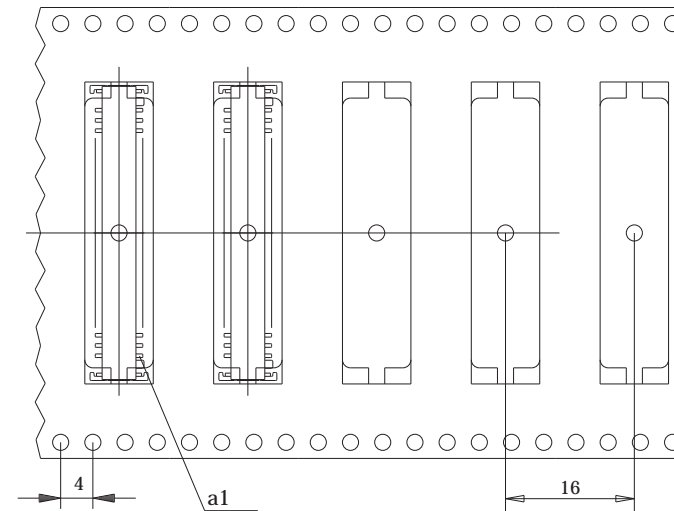

Anforderungsstufe 1
Performance Level 1
Kontaktbereich vergoldet
Mating Area gold plating
Anschlussbereich verzinkt 4-6 µm
Terminal Area 4-6 µm tin plating
Koplanarität der Anschlüsse ≤ 0.1 mm
Coplanarity Area of Termination ≤ 0.1 mm

Leiterplatten-Layout Vorschlag für SMT
PCB-Layout Proposal for SMT

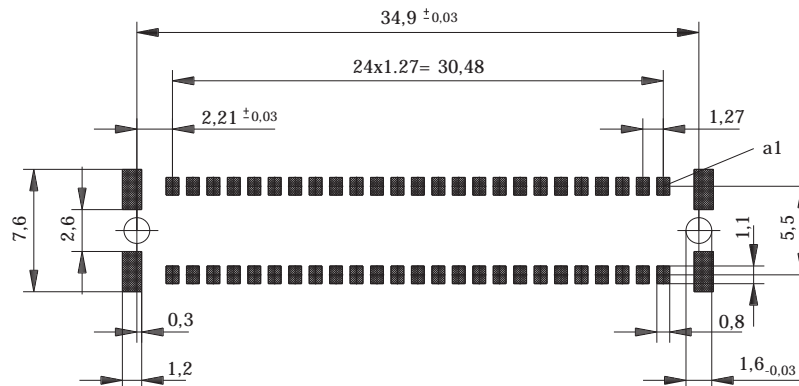

8mm Bauhöhe
low profile

Consider protection memo from DIN 34

All rights reserved.
Only for information.
To insure that this is the latest version of this drawing, please contact one of the ERNI companies before using.
Subject to modification without prior notice.
Drawing will not be updated.

Tolerances



All Dimensions in mm

Scale 3:1

Designation

Federleiste SMC-B, 50 polig
Fem. Conn. SMC-B, 50 contacts

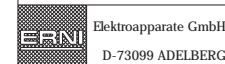

064316

1

O:00010160.SZN