



GERM/GELM

mm

igubal® Clevis Joints

Phone +44 (0) 16 04 - 67 72 40
Fax +44 (0) 16 04 - 67 72 45

igubal® UK Ltd.

Internet www.igus.co.uk
E-mail sales@igus.co.uk

52.4



Data in mm

Structure – part no.

GE ... M - 04

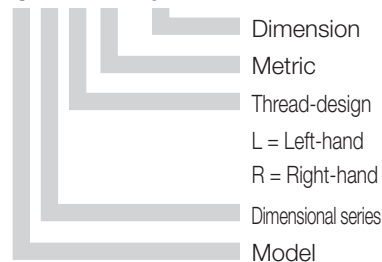

Special Properties

- Light weight
- Universal corrosion resistance
- High tensile strength
- Can be used in combination with series E rod ends
- Vibration dampening
- Noise dampening
- Available in left and right hand thread



Material

igumid G

▶ Page 70.6

Load Data

igubal® – Clevis Joints

Part Number		Max. Static Axial Tensile Strength GER(L)M		Max. Radial Load		Max. Torque Strength
		Short term	Long term	Short term	Long term	
Right-hand-thread	Left-hand-thread	[N]	[N]	[Nm]	[N]	[N]
GERM-04 M3.5	GELM-04 M3.5	650	325	250	125	0,4
GERM-04	GELM-04	650	325	250	125	0,4
GERM-05 DIN M4	GELM-05 DIN M4	1000	500	250	125	0,4
GERM-05 DIN M5	GELM-05 DIN M5	1000	500	250	125	0,5
GERM-05	GELM-05	1200	600	250	125	0,5
GERM-05 DIN M5 LS	GELM-05 DIN M5 LS	1000	500	130	65	0,5
GERM-06	GELM-06	1400	700	300	150	1,5
GERM-06 LS	GELM-06 LS	1400	700	130	65	1,5
GERM-08	GELM-08	2700	1350	650	325	5
GERM-10	GELM-10	4700	2350	800	400	15
GERM-10 F	GELM-10 F	4700	2350	800	400	6
GERM-12	GELM-12	5700	2850	900	450	20
GERM-12 F	GELM-12 F	5700	2850	900	450	15
GERM-14	GELM-14	6600	3300	1000	500	25
GERM-15	GELM-15	3200	1600	1000	500	25
GERM-16	GELM-16	7500	3750	1200	600	30
GERM-16 F	GELM-16 F	7500	3750	1200	600	27,5
GERM-17	GELM-17	3600	1800	1200	600	30
GERM-17 F	GELM-17 F	3600	1800	1200	600	27,5
GERM-20	GELM-20	9500	4750	3000	1500	60
GERM-20 M20	GELM-20 M20	9500	4750	3000	1500	80

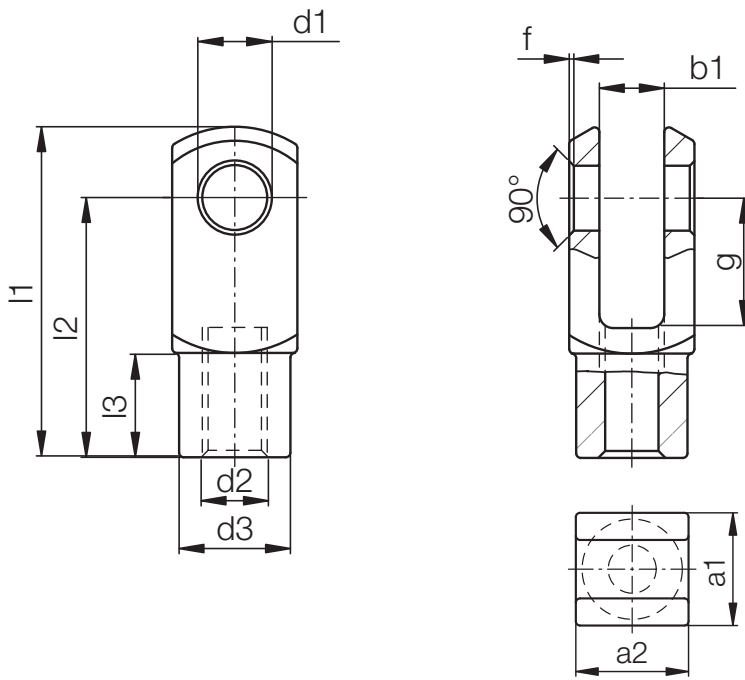

igubal® Clevis Joints

GERM/GELM

mm

Phone +44 (0) 16 04 - 67 72 40

Fax +44 (0) 16 04 - 67 72 45

Dimensions [mm]

igubal® – Clevis Joints Dimensional Series E – Clevis Joints only (GERM / GELM), without clevis pin and circlip

Part Number		d1	g	a1	a2	b1	d2	d3	f	l1	l2	l3
		H9	h11		+0,3 -0,16	B13	Thread- tolerance 6H	+0,3 -0,3	+0,3 -0,3	+0,5 -0,5	+0,3 -0,3	+0,2 -0,2
	Right-hand-thread / Left-hand-thread											
GERM-04 M3.5	GELM-04 M3.5	4	8	8	8	4	M3.5	8,0	0,5	21,0	16,0	6,0
GERM-04	GELM-04	4	8	8	8	4	M04	8,0	0,5	21,0	16,0	6,0
GERM-05 DIN M4	GELM-05 DIN M4	5	10	10	10	5	M04	9,0	0,5	25,0	20,0	7,5
GERM-05 DIN M5	GELM-05 DIN M5	5	10	10	10	5	M05	9,0	0,5	25,0	20,0	7,5
GERM-05	GELM-05	5	12	12	12	6	M05	10,0	0,5	31,0	24,0	9,0
GERM-05 DIN M5 LS	GELM-05 DIN M5 LS	5	20	10	10	5	M05	9,0	0,5	36,0	30,0	7,5
GERM-06	GELM-06	6	12	12	12	6	M06	10,0	0,5	31,0	24,0	9,0
GERM-06 LS	GELM-06 LS	6	24	12	12	6	M06	10,0	0,5	43,0	36,0	9,0
GERM-08	GELM-08	8	16	16	16	8	M08	14,0	0,5	42,0	32,0	12,0
GERM-10	GELM-10	10	20	20	20	10	M10	18,0	0,5	52,0	40,0	15,0
GERM-10 F	GELM-10 F	10	20	20	20	10	M10x1,25	18,0	0,5	52,0	40,0	15,0
GERM-12	GELM-12	12	24	24	24	12	M12	20,0	0,5	62,0	48,0	18,0
GERM-12 F	GELM-12 F	12	24	24	24	12	M12x1,25	20,0	0,5	62,0	48,0	18,0
GERM-14	GELM-14	14	28	27	27	14	M14	24,0	0,5	72,0	56,0	22,5
GERM-15	GELM-15	15	28	27	27	14	M14	24,0	0,5	72,0	56,0	22,5
GERM-16	GELM-16	16	32	32	32	16	M16	26,0	1,0	83,0	64,0	24,0
GERM-16 F	GELM-16 F	16	32	32	32	16	M16x1,5	26,0	1,0	83,0	64,0	24,0
GERM-17	GELM-17	17	32	32	32	16	M16	26,0	1,0	83,0	64,0	24,0
GERM-17 F	GELM-17 F	17	32	32	32	16	M16x1,5	26,0	1,0	83,0	64,0	24,0
GERM-20	GELM-20	20	40	40	40	20	M20x1,5	34,0	1,0	105,0	80,0	30,0
GERM-20 M20	GELM-20 M20	20	40	40	40	20	M20x2,5	34,0	1,0	105,0	80,0	30,0

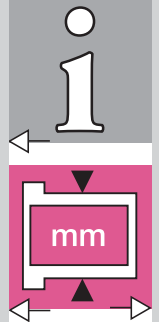



Data in mm

Structure – part no.

G E ... M F-04

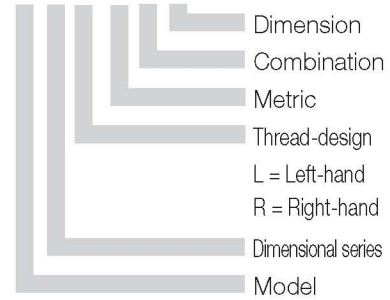

Special Properties

- Single piece design
- Easy to assemble
- Maintenance-free
- Can be used in combination with series E rod ends
- High stability



Material

igumid G

▶ Page 70.6

Load Data

igubal® – Clevis Joints with Spring-Loaded-Pins

Part Number		Max. Static Axial Tensile Strength		Max. Radial Load	
Right-hand-thread	Left-hand-thread	Short Term	Long Term	Short Term	Long Term
		[N]	[N]	[N]	[N]
GERMF-04	GELMF-04	500	250	250	125
GERMF-04 M3.5	GELMF-04 M3.5	500	250	250	125
GERMF-05 DIN M4	GELMF-05 DIN M4	800	400	250	125
GERMF-05 DIN M5	GELMF-05 DIN M5	800	400	250	125
GERMF-05 DIN M5 LS	GELMF-05 DIN M5 LS	800	400	250	125
GERMF-05	GELMF-05	900	450	250	125
GERMF-05 LS	GELMF-05 LS	800	400	130	65
GERMF-06	GELMF-06	1300	650	300	150
GERMF-06 LS	GELMF-06 LS	1300	650	130	65
GERMF-08	GELMF-08	2100	1050	650	325
GERMF-10	GELMF-10	3000	1500	800	400
GERMF-10 F	GELMF-10 F	3000	1500	800	400
GERMF-12	GELMF-12	3500	1750	900	450
GERMF-12 F	GELMF-12 F	3500	1750	900	450
GERMF-16	GELMF-16	7000	3500	1200	600
GERMF-16 F	GELMF-16 F	7000	3500	1200	600

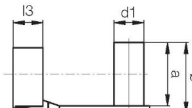
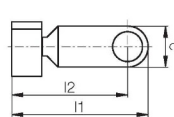

Material

igumid G

▶ Seite 70.6

Dimensions [mm]

igubal® Spring-Loaded-Pins GEFM

Part Number	d1 h11	d2	a	b	c	l1 ±0.5	l2	l3
GEFM-04	4	8	9,5	10,5	8	19	15	4,5
GEFM-05 DIN	5	9	12	13,5	8	23	19	5,5
GEFM-05	5	10	14	15,5	8	27	23	6,5
GEFM-06	6	10	14	15,5	8	27	23	6,5
GEFM-08	8	14	19	21,0	11	35,5	30	8,0
GEFM-10	10	18	23	25,5	14	45	38	10,0
GEFM-12	12	20	28	31,0	16	53	45	12,0
GEFM-16	16	26	36	40,0	22	73	62	16,0



Single components:

Spring-Loaded Pin GEFM

▶ Page 52.9

igubal® Clevis Joints

GERMK/GELMK

mm

Phone +44 (0) 1604 - 67 72 40

Fax +44 (0) 1604 - 67 72 45

