

TEST/CHARACTERISTICS	MIL-C-39012 A	VALUES/REMARKS
----------------------	---------------	----------------

### ELECTRICAL CHARACTERISTICS

Impedance		50 Ω			
Frequency range		DC-4 GHz			
V.S.W.R. (typ.) Straight models	cable group: Frequency .085" 2 2.6	3-14	1 GHz 1.12 1.10 1.12	2.5 GHz 1.22 1.22 1.22	4 GHz 1.33 1.33 1.35
Right angle models	.085" 2		1.10 1.10	1.18 1.20	1.26 1.25
Insertion loss (typ.) Straight models	cable group: .085" 2 2.6	3-27	0.05 0.05 0.05	0.07 0.10 0.05	0.15 0.25 0.05
Right angle models	.085"		0.05	0.07	0.12
RF leakage		3-26	-55 dB min from 2 to 3 GHz		
Insulation resistance		3-11	1000 MΩ min		
Contact resistance	center contact (mΩ) outer contact (mΩ)	3-16	Initial 6 1	After test 8 1.5	
Working voltage	Cable group at sea level at 70000 ft (21000 m)		2/50 250 V rms 60 V rms	2.6/50 335 V rms 85 V rms	
Dielectric withstanding voltage	Cable group at sea level at 70000 ft (21000 m)	3-17	2/50 750 V rms 185 V rms	2.6/50 1000 V rms 250 V rms	
RF withstanding voltage (5 MHz sine wave)	Cable group at sea level	3-23	2/50 500 V rms	2.6/50 700 V rms	

### MECHANICAL CHARACTERISTICS

Durability		3-15	500 matings		
Mating / unmating		3-5-1	axial force : 62 N max (14 Lbf)		
Cabling retention force	cable group: 2/50 2.6/50	3-24	58 N (13 Lbf) 110 N (25 Lbf)		
Center contact retention			Axial : 10 N (2.25 Lbf)		

### ENVIRONMENTAL CHARACTERISTICS

Temperature range	standard models hermetic sealed models models for semi-rigid cables		-65° C / + 165° C -65° C / +165° C -65° C / +105° C		
Combined climate tests			MIL-STD-202. method 102. condition C		
Thermal shock		3-20	MIL-STD-202. method 107. condition B		
High temperature endurance			MIL-STD-202. method 108		
Corrosion (salt spray)		3-13	MIL-STD-202. method 101. condition B, 5%		

All dimensions are given in millimeters

Standard packaging : 100 pieces (Same part number). For unit packaging, add "W" after the P/N.

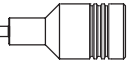

### ENVIRONMENTAL CHARACTERISTICS

Vibrations	3-18	MIL-STD-202. method 204. condition B, 15g
Shocks	3-19	MIL-STD-202. method 213. condition B, 75g
Low pressure	3-22	MIL-STD-202. method 105. condition C
Hermetic seal		applied vacuum $10^{-6}$ mm of Hg (Torr) leakage rate $< 10^{-6}$ atm/cm <sup>3</sup> /s

### MATERIALS

Body and center pin contact		half hard brass as per QQ-B-626
Center socket contact		beryllium copper as per QQ-C-530
Ferrules		brass
Insulators		PTFE teflon
Gaskets		silicone elastomer

### PLATING

Body		gold or nickel
Center contacts		gold

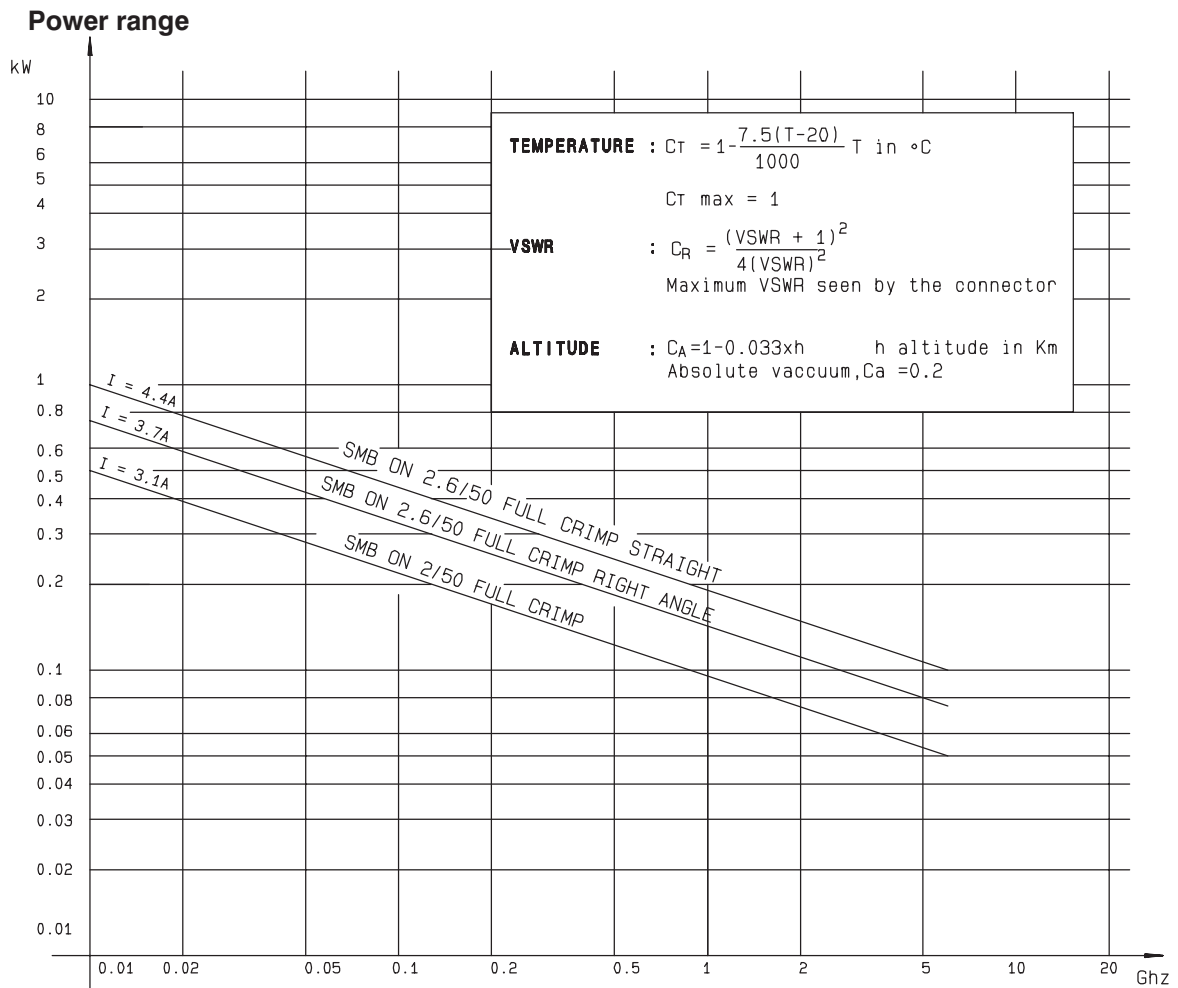

All dimensions are given in millimeters

Standard packaging : 100 pieces (Same part number). For unit packaging, add "W" after the P/N.



## STRAIGHT PLUG SOLDER TYPE FOR SEMI RIGID CABLE

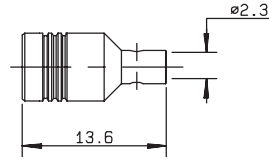

cable	part number	captive center contact	assembly	finish
.085"	R114 053 000	no	M08	Gold

## RIGHT ANGLE PLUGS CRIMP TYPE FOR FLEXIBLE CABLES

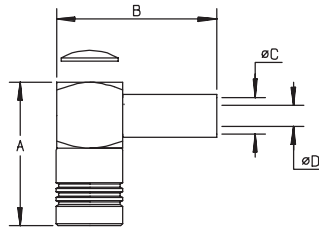

Fig. 1

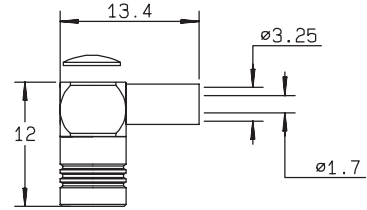

Fig. 2

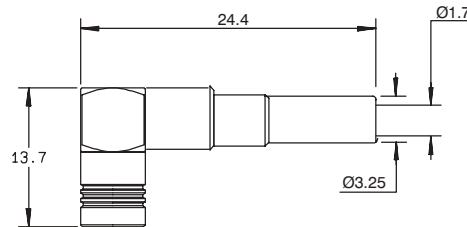

Fig. 3

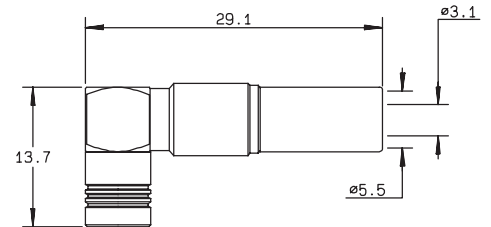

Fig. 4

cable	part number	fig.	dimensions				captive center contact	assembly	finish	note
			A	B	C	D				
2/50/S	R114 183 000	1	13.8	15.7	2.55	0.95	yes	M06	Gold	
2/50/S	R114 183 020	1	13.8	15.7	2.55	0.95	yes	M06	Nickel	
2/50/S	R114 183 430	1	13.7	15.3	3.25	0.95	yes	M06	Nickel	1/2 body Zamak
2.6/50+75/S	R114 185 000	2					yes	M06	Gold	short version
2.6/50+75/S	R114 185 020	2					yes	M06	Nickel	short version
2.6/50+75/S	R114 186 000	1	13.8	15.7	3.25	1.7	yes	M06	Gold	
2.6/50+75/S	R114 186 020	1	13.8	15.7	3.25	1.7	yes	M06	Nickel	
2.6/50+75/S	R114 186 420*●	3					yes	M10	Nickel	full crimp
2.6/50+75/S	R114 186 730	1	13.7	15.3	3.25	1.7	yes	M06	Nickel	1/2 body Zamak
2.6/50+75/S	R114 187 000	1	15.1	15.7	3.25	1.7	yes	M09	Gold	full crimp
2.6/50+75/S	R114 187 020	1	15.1	15.7	3.25	1.7	yes	M09	Nickel	full crimp
2.6/50/D	R114 182 000	1	13.8	15.7	3.25	1.7	yes	M06	Gold	
2.6/50/D	R114 191 130	1	13.7	15.3	3.5	1.7	yes	M06	Nickel	1/2 body Zamak
3.6/75/D	R114 191 300	1	13.7	18.3	4.4	2.1	yes	M06	Gold	cable BT 3002
5/50/S	R114 192 420*●	4					yes	M10	Nickel	full crimp

● upon request

\* packaging: unit

## M 06

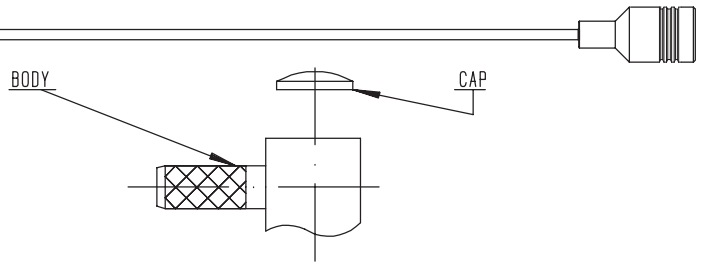
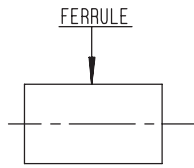

P/N	STRIPPING DIM.			HEX. DIM. H	CRIMP TOOLS			
	a	b	c		DIES INCLUDED	MIL STANDARD R282 293 000 (M22520/5-01)+DIES		
R114 182 000	1.5	2.7	5.4	3.25	R282 211 000	R282 235 003 (M22520/5-03)		
R114 183 000				2.67				
R114 183 020								
R114 183 430								
R114 185 000	1.5	2.5	4.5	3.25				
R114 185 020								
R114 186 000	1.5	2.7	5.4	3.84			R282 271 000	R282 235 037 (M22520/5-37)
R114 186 020				4.53			R282 211 000	R282 235 009 (M22520/5-09)
R114 186 730				3.25				R282 235 003 (M22520/5-03)
R114 191 130				3.84			R282 271 000	R282 235 037 (M22520/5-37)
R114 191 300				2.67	R282 211 000	R282 235 003 (M22520/5-03)		
R114 373 020				3.25				
R114 373 120				3.84	R282 271 000	R282 235 037 (M22520/5-37)		
R116 372 000				2.67	R282 211 000	R282 235 003 (M22520/5-03)		
R116 373 000				3.25				

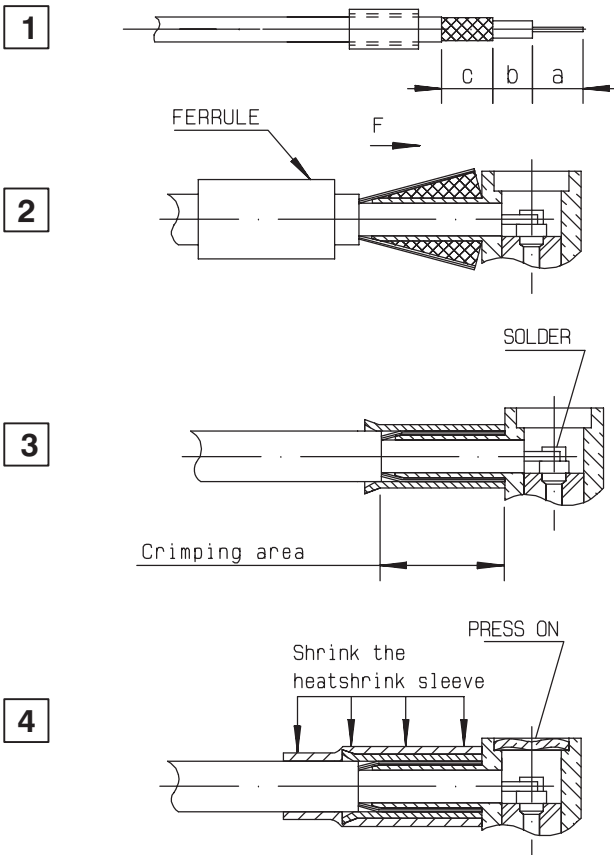

- 1.1 Slide the ferrule onto the cable.
- 1.2 Strip the cable.
- 2.1 Fan the braid
- 2.2 Push the connector body under the braid.
- 2.3 Slide the ferrule over the braid (in direction F).
- 3.1 Crimp the ferrule.
- 3.2 Solder the inner conductor.
- 4.1 Press the cap into the body.
- 4.2 Press the cap flush or slightly below surface of body assembly.