



FAN8303

2A 23V Non-Synchronous Step-Down DC/DC Regulator

Features

- 2A Output Current
- 0.22Ω Internal Power MOSFET Switch
- Wide 5V to 23V Operating Input Range
- Output Adjustable from 0.6 to 20V
- Stable with Low ESR Output Ceramic Capacitors
- Up to 90% Efficiency
- Less than 40μA Shutdown Current
- Fixed 370kHz Frequency
- Thermal Shutdown with Hysteresis
- Cycle-by-Cycle Over-Current Protection
- Available in 8-Pin SOIC Package

Applications

- Set-Top Box
- DSL and Cable Modems
- Distributed Power Systems
- Consumer Appliances (DVD)
- Auxiliary supplies

Description

The FAN8303 is a monolithic, non-synchronous, step-down (buck) regulator with internal power MOSFETs. It achieves 2A continuous output current over a wide input supply range with excellent load and line regulation. Current-mode operation provides fast transient response and eases loop stabilization. Fault condition protection includes cycle-by-cycle current limiting and thermal shutdown. The regulator draws less than 40μA shutdown current. FAN8303 requires a minimum number of readily available standard external components.

External compensation, enable, and programmable soft-start features allow design optimization and flexibility. Cycle-by-cycle current limit, frequency foldback, and thermal shutdown provide protection against shorted outputs.

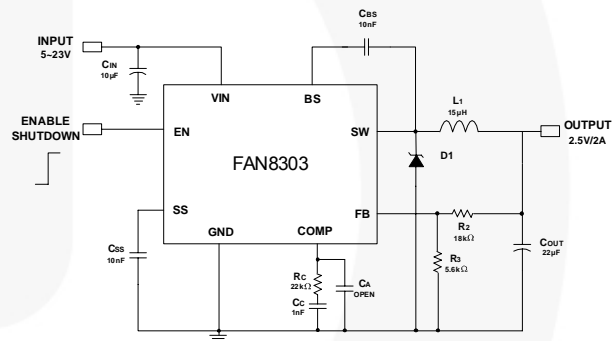

Figure 1. Typical Application

Ordering Information

Part Number	Eco Status	Operating Temperature Range	Package	Packing Method
FAN8303MX	RoHS	-40°C to +85°C	8-SOIC	Reel

For Fairchild's definition of "green" Eco Status, please visit: http://www.fairchildsemi.com/company/green/rohs_green.html.

Internal Block Diagram

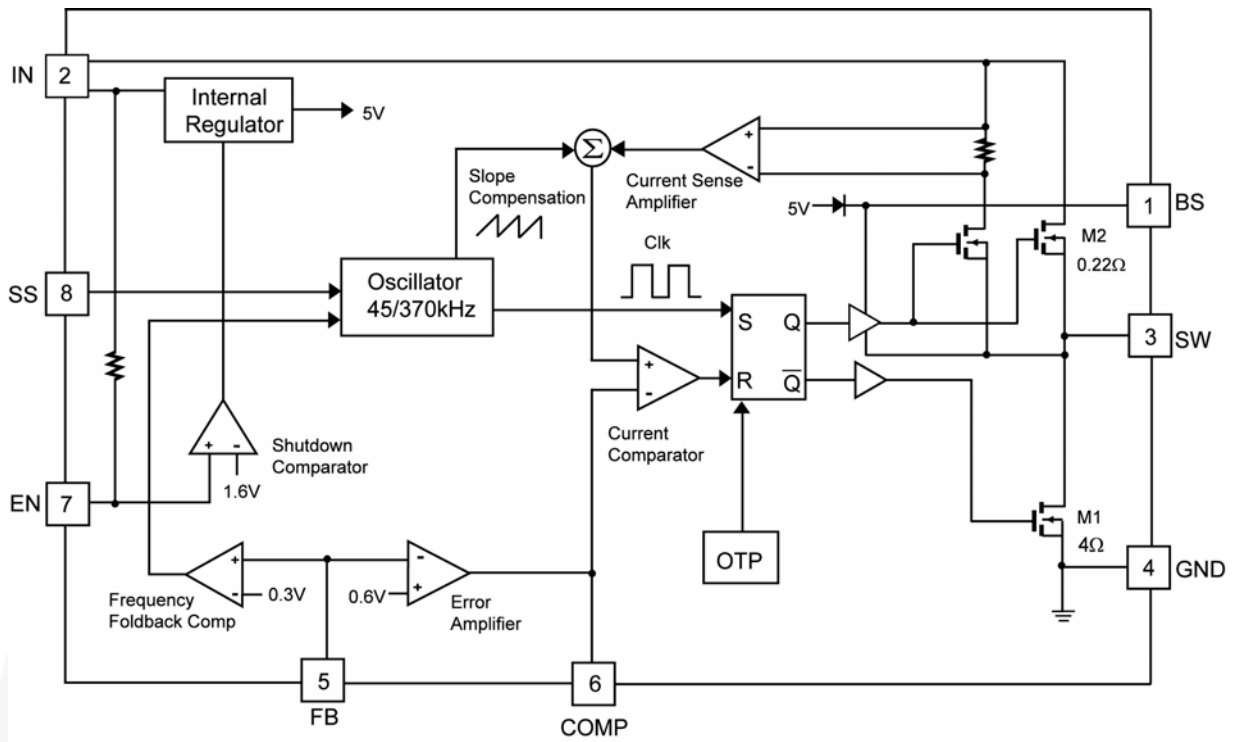

Figure 2. Functional Block Diagram

Pin Configuration

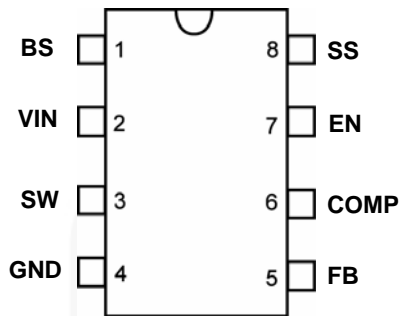

Figure 3. Pin Configuration (Top View)

Pin Definitions

Name	Pin #	Type	Description
BS	1	Bootstrap	High-Side Drive BOOT Voltage. Connect through capacitor (C_{BS}) to SW. The IC includes an internal synchronous bootstrap diode to recharge the capacitor on this pin to V_{CC} when SW is LOW.
V_{IN}	2	Supply Voltage	Power Input. This pin needs to be closely decoupled to the GND pin with a $10\mu\text{F}$ or greater ceramic capacitor.
SW	3	Switch	Power Switching Output. SW is the switching node that supplies power to the output.
GND	4	Ground	Power Return and Signal Ground for the IC. All internal control voltages are referred to this pin. Tie this pin to the ground island / plane through the lowest impedance connection. This pin is the ground reference for the regulated output voltage.
FB	5	Feedback	Feedback Input. This pin is the center tap of the external feedback voltage resistive divider across the output.
COMP	6	Compensation	Compensation Node. Frequency compensation is accomplished at this node by connecting a series R-C to ground.
EN	7	Enable	Enable Input. EN is a digital input that turns the regulator on or off. Drive EN HIGH to turn on the regulator, drive it LOW to turn it off. For automatic startup, leave EN unconnected.
SS	8	Soft Start	External Soft-Start. A capacitor connected between this pin and GND can be used to set soft-start time.

Absolute Maximum Ratings

Stresses exceeding the absolute maximum ratings may damage the device. The device may not function or be operable above the recommended operating conditions and stressing the parts to these levels is not recommended. In addition, extended exposure to stresses above the recommended operating conditions may affect device reliability. The absolute maximum ratings are stress ratings only. All voltage values, except differential voltages, are given with respect to the network ground terminal. Stresses beyond those listed under Absolute Maximum Ratings may cause permanent damage to the device

Symbol	Parameter		Min.	Max.	Unit
V_{IN}	Supply Voltage, VIN to GND			25	V
V_{SW}	Switch Voltage, SW to GND		-0.3	$V_{IN}+0.3$	V
V_{BS}	Boost Voltage			$V_{SW} + 6$	V
V_{FB}	Feedback Voltage		-0.3	6.0	V
V_{EN}	Enable Voltage		-0.3	6.0	V
V_{COMP}	Compensation Voltage		-0.3	6.0	V
V_{SS}	Soft-Start Voltage		-0.3	6.0	V
Θ_{JA}	Thermal Resistance, Junction-Air			105	°C/W
Θ_{JC}	Thermal Resistance, Junction-Case			40	°C/W
T_J	Operating Junction Temperature		-40	+125	°C
T_L	Lead Temperature (Soldering, 5 Seconds)			+260	°C
T_{STG}	Storage Temperature Range		-65	+150	°C
ESD	Electrostatic Discharge Protection Level	Human Body Model, JEDEC JESD22-A114	3.0		kV
		Charged Device Model, JEDEC JESD22-C101	2.5		

Recommended Operating Conditions

The Recommended Operating Conditions table defines the conditions for actual device operation. Recommended operating conditions are specified to ensure optimal performance to the datasheet specifications. Fairchild does not recommend exceeding them or designing to absolute maximum ratings.

Symbol	Parameter	Min	Max.	Unit
V_{IN}	Supply Voltage	5	23	V
T_A	Operating Ambient Temperature	-40	+85	°C

Electrical Characteristics

$V_{IN}=12V$, $T_A=-40$ to $+85^{\circ}C$, unless otherwise noted.

Symbol	Parameter	Condition	Min.	Typ.	Max.	Unit
V_{FB}	Feedback Voltage	$25^{\circ}C$, $5V < V_{IN} < 23V$	0.58	0.60	0.62	V
R_{ON_H}	Upper Switch On Resistance			0.22		Ω
R_{ON_L}	Lower Switch On Resistance			4		Ω
I_{LKG}	Upper Switch Leakage Current	$V_{EN}=0V$, $V_{SW}=0V$		0	10	μA
I_{PK}	Peak Inductor Current			3.5		A
f_{OSC}	Oscillator Frequency	$V_{FB} > 0.3V$	315	370	435	kHz
V_{UVLO}	Under-Voltage Lockout	Rising V_{IN}	4.2	4.6	5.0	V
f_{SHORT}	Short Circuit Frequency	$V_{FB} < 0.3V$	25	45	55	kHz
D_{MAX}	Maximum Duty Cycle			90		%
T_{ON_MIN}	Minimum On Time			210		ns
V_{EN}	Enable Threshold		1.2	1.6	2.0	V
V_{EN_H}	Enable Threshold Hysteresis			150		mV
I_{OFF}	Supply Current (Shutdown)	$V_{EN}=0V$		10	40	μA
I_Q	Supply Current (Quiescent)	$V_{EN} > 1.6V$; $V_{FB}=0.8V$		1.0	2.0	mA
G_{CS}	Current Sense Gain			2		A/V
G_{EA}	Error Amplifier Transconductance			380		$\mu A/V$
A_{VEA}	Error Amplifier Voltage Gain			400		V/V
I_{SS}	Soft-Start Current			6		μA
TSD	Thermal Shutdown Temperature			155		$^{\circ}C$

Typical Performance Characteristics

$V_{IN} = 12V$, $V_{OUT} = 5V$, $L1 = 15\mu H$, $C_{IN} = 10\mu F$, $C_{OUT} = 22\mu F$, $T_A = +25^\circ C$, unless otherwise noted.

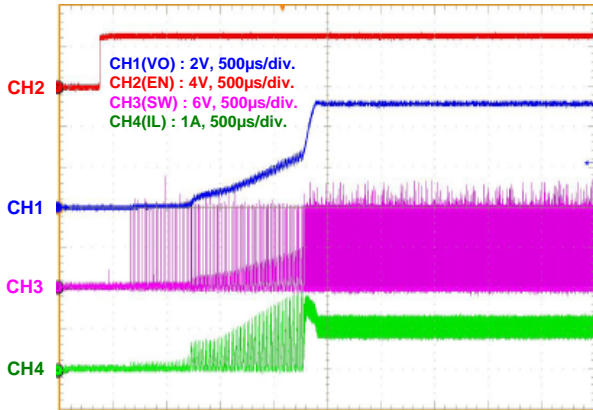

Figure 4. EN Startup with 2A Load

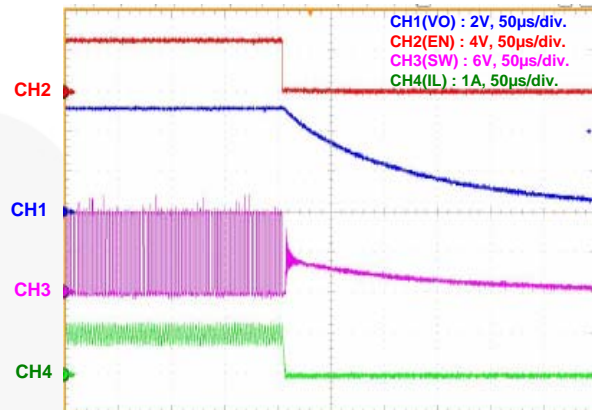

Figure 5. EN Turn-off with 2A Load

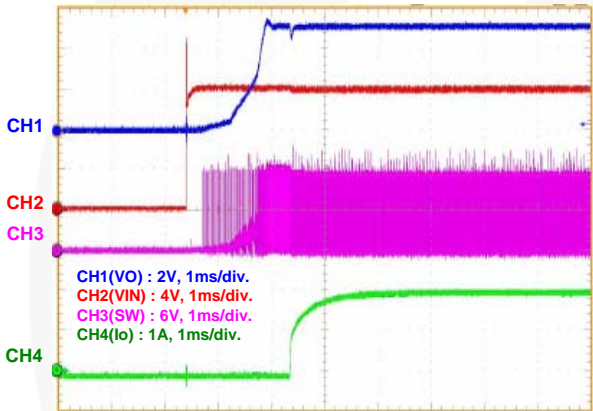

Figure 6. Power-on with 2A Load

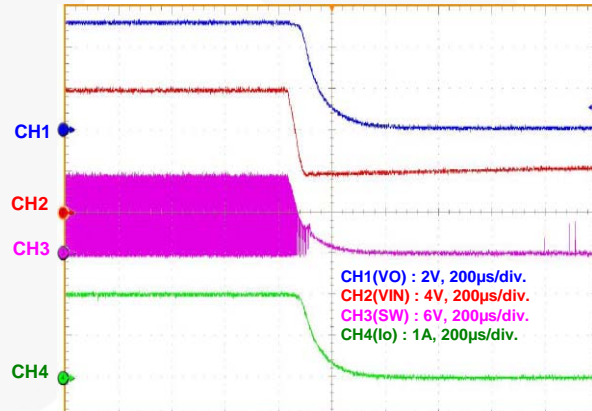

Figure 7. Power-off with 2A Load

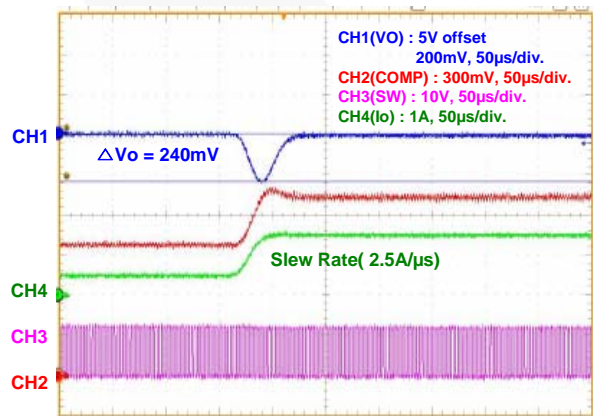

Figure 8. Load Transient Response (0.5A to 1.5A)

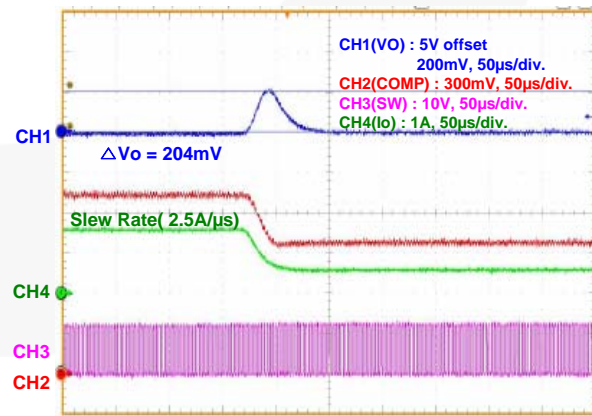

Figure 9. Load Transient Response (1.5A to 0.5A)

Typical Performance Characteristics (Continued)

$V_{IN} = 12V$, $V_{OUT} = 5V$, $L1 = 15\mu H$, $C_{IN} = 10\mu F$, $C_{OUT} = 22\mu F$, $T_A = +25^\circ C$, unless otherwise noted.

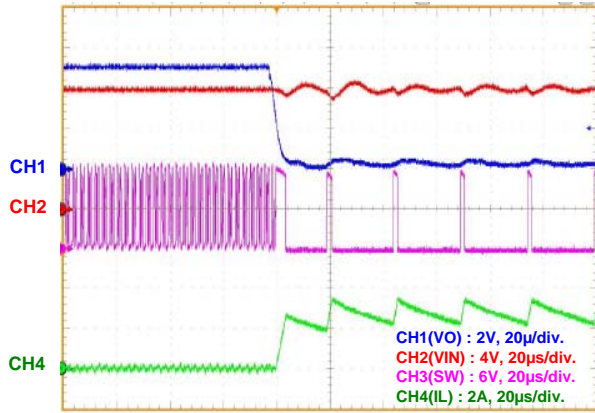

Figure 10. Hard-Short at Output (OCP)

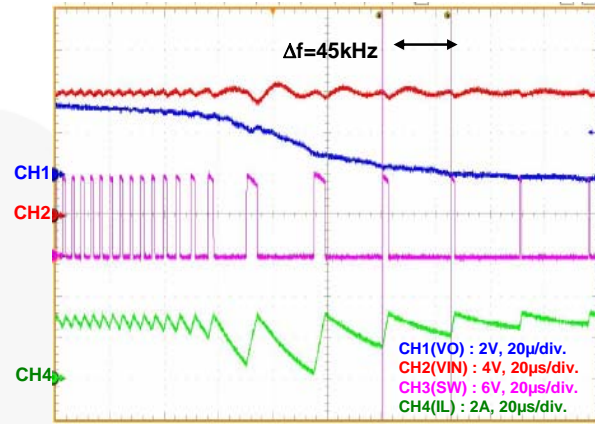

Figure 11. Overload at Output (OCP)

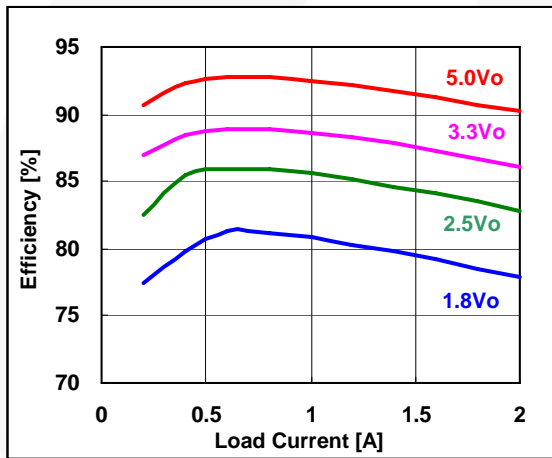

Figure 12. Efficiency Curve

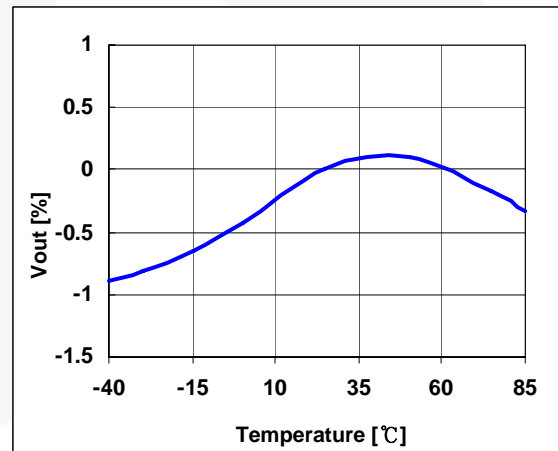

Figure 13. Normalized Output Voltage vs. Temperature

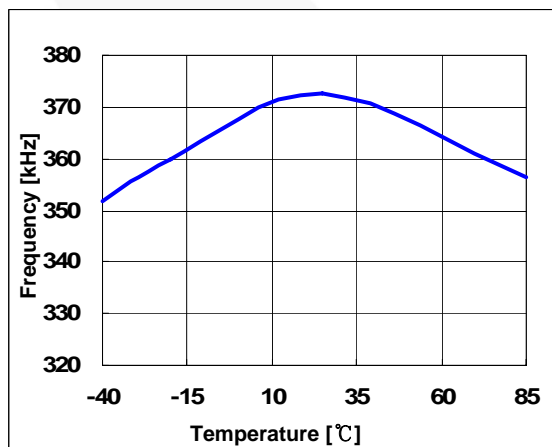

Figure 14. Oscillator Frequency vs. Temperature

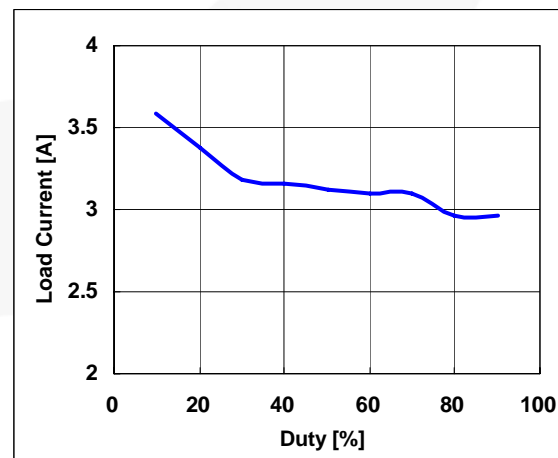

Figure 15. Current Limited Level vs. Duty Ratio

Functional Description

The FAN8303 is a monolithic, non-synchronous, current-mode, step-down regulator with internal power MOSFETs. It achieves 2A continuous output current over a wide input supply range from 5V to 23V with excellent load and line regulation. The output voltage can be regulated as low as 0.6V. The FAN8303 uses current-mode operation that provides fast transient response and eases loop stabilization. The FAN8303 requires a minimum number of readily available standard external components.

Current Mode PWM Control Loop

FAN8303 uses current-mode PWM control scheme. The peak inductor current is modulated in each switching cycle by an internal op-amp output signal to achieve the output voltage regulation. An internal slope compensation circuit is included to avoid sub-harmonic oscillation at duty cycle greater than 50%. Current-mode control provides cycle-by-cycle current limit protection and superior regulation control loop response compared to the traditional voltage-mode control.

In normal operation, the high-side MOSFET is turned on at the beginning of each switching cycle, which causes the current in the inductor to build up. The current-control loop senses the inductor current by sensing the voltage across the high-side senseFET during on time. The output of the current-sense amplifier is summed with the slope compensation signal and the combined signal is compared with the error amplifier output to generate the PWM signal. As the inductor current ramps up to the controlled value, the high-side MOSFET is turned off and the inductor current reaches zero through a freewheeling diode. In light-load condition, the high-side switch may be kept off for several cycles to improve efficiency.

Short-Circuit Protection

The FAN8303 protects output short circuit by switching frequency fold-back. The oscillator frequency is reduced to about 45kHz when the output is shorted to ground. This frequency fold-back allows the inductor current more time to decay to prevent potential run-away condition. The oscillator frequency switches to 370kHz as V_{OUT} rises gradually from 0V back to regulated level.

Slope Compensation and Inductor Peak Current

The slope compensation provides stability in constant frequency architecture by preventing sub-harmonic oscillations at high duty cycles. It is accomplished internally by adding a compensating ramp to the inductor current signal at duty cycles in excess of 50%.

Maximum Load Current at Low V_{IN}

The FAN8303 is able to operate with input supply voltage as low as 5V, although the maximum allowable output current is reduced as a function of duty cycle (see Figure 15). Additionally, at this low input voltage; if the duty cycle is greater than 50%, slope compensation reduces allowable output current.

Inductor Selection

A higher inductor value lowers ripple current. The inductor value can be calculated as:

$$L = \frac{V_{OUT}}{f_s \cdot \Delta I_L} \left(1 - \frac{V_{OUT}}{V_{IN}} \right) \quad (1)$$

where:

f_s is the switching frequency;

V_{OUT} is the output voltage;

V_{IN} is the input supply voltage; and

ΔI_L is the inductor ripple current.

Considering worst case, the equation is changed to:

$$L = \frac{V_{OUT}}{f_s \cdot \Delta I_{L,MAX}} \left(1 - \frac{V_{OUT}}{V_{IN,MAX}} \right) \quad (2)$$

Input Capacitor Selection

To prevent high-frequency switching current passing to the input, the input capacitor impedance at the switching frequency must be less than input source impedance. High-value, small, inexpensive, lower-ESR ceramic capacitors are recommended. 10 μ F ceramic capacitors should be adequate for 2A applications.

Output Capacitor Selection

A larger output capacitor value keeps the output ripple voltage smaller. The formula of output ripple ΔV_{OUT} is:

$$\Delta V_{OUT} \cong \Delta I_L \left(ESR + \frac{1}{8 \cdot C_{OUT} \cdot f_s} \right) \quad (3)$$

where C_{OUT} is the output capacitor and ESR is the equivalent series resistance of the output capacitor.

Output Voltage Programming

The output voltage is set by a resistor divider, according to the following equation:

$$V_{OUT} = 0.6 \left(1 + \frac{R2}{R3} \right) \quad (4)$$

Freewheeling Diode

An output freewheeling diode carries load current when the high-side switch is turned off. Therefore, use a Schottky diode to reduce loss due to diode forward voltage and recovery time. The diode should have at least 2A current rating and a reverse blocking voltage greater than the maximum input voltage. The diode should be close to the SW node to keep traces short and reduce ringing.

Soft-Start

A capacitor, C_{SS} , connected between the SS pin and GND helps control the rate of rise on the output voltage. When EN is HIGH and V_{IN} is within the operating range, a trimmed bias current charges the capacitor connected to the SS pin, causing the voltage to rise.

The time it takes this voltage to reach 0.6V and the PWM output to reach regulation is given by:

$$t_{RISE}(ms) \approx 0.1 \cdot C_{SS} \quad (5)$$

where C_{SS} is in nF.

Loop Compensation

The goal of the compensation design is to shape the converter frequency response to achieve high DC gain and fast transient, while maintaining loop stability. FAN8303 employs peak current-mode control for fast transient response and to help simplify the loop to a one-pole and one-zero system.

The system pole is calculated by the equation:

$$f_{P1} = \frac{1}{2\pi \cdot C_{OUT} \cdot R_L} \quad (6)$$

where R_L is the load resistor value (V_{OUT}/I_{OUT}).

The system zero is due to the output capacitor and its ESR system zero is calculated by following equation:

$$f_{Z1} = \frac{1}{2\pi \cdot C_{OUT} \cdot ESR} \quad (7)$$

The characteristics of the control system are controlled by a series capacitor and resistor network connected to the COMP pin to set the pole and zero.

The pole is calculated by the following equation:

$$f_{P2} = \frac{G_{EA}}{2\pi \cdot C_C \cdot A_{VEA}} \quad (8)$$

where:

G_{EA} is the error amplifier transconductance (380 μ A/V);

A_{VEA} is the error amplifier voltage gain (400V/V); and

C_C is the compensation capacitor.

Zero is due to the compensation capacitor (C_C) and resistor (R_C) calculated by the following equation:

$$f_{Z2} = \frac{1}{2\pi \cdot C_C \cdot R_C} \quad (9)$$

where R_C is compensation resistor.

The system crossover frequency (f_c), where the control loop has unity gain, is recommended for setting the 1/10th of switching frequency. Generally, higher f_c means faster response to load transients, but can result in instability if not properly compensated.

The first step of the compensation design is choosing the compensation resistor (R_C) to set the crossover frequency by the following equation:

$$R_C = \frac{2\pi \cdot C_{OUT} \cdot f_c \cdot V_{OUT}}{G_{CS} \cdot G_{EA} \cdot V_{FB}} \quad (10)$$

where V_{FB} is reference voltage and G_{CS} is the current sense gain, which is roughly the output current divided by the voltage at COMP (2A/V).

The next step is choosing the compensation capacitor (C_C) to achieve the desired phase margin. For applications with typical inductor values, setting the compensation zero, f_{Z2} , to below one fourth of the crossover frequency provides sufficient phase margin. Determine the (C_C) value by the following equation:

$$C_C = \frac{2}{\pi \cdot R_C \cdot f_c} \quad (11)$$

Determine if the second compensation capacitor (C_A) is required. It is required if the ESR zero of the output capacitor is located at less than half of the switching frequency.

$$\frac{1}{2\pi \cdot C_{OUT} \cdot ESR} < \frac{f_S}{2} \quad (12)$$

If required, add the second compensation capacitor (C_A) to set the pole f_{P3} at the location of the ESR zero. Determine the (C_A) value by the equation:

$$C_A = \frac{C_{OUT} \cdot ESR}{R_C} \quad (13)$$

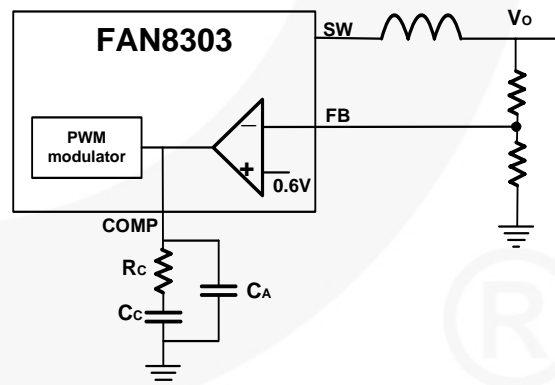

Figure 16. Block Diagram of Compensation

Design example

Assume the V_{IN} voltage is 12V with a 10% tolerance. The maximum load current is 2A and the output voltage is set to 2.5V at 2A maximum load. Calculate the inductor value from the following formula:

$$L = \frac{V_{OUT}}{f_{OSC} \cdot \Delta I_{L,MAX}} \left(1 - \frac{V_{OUT}}{V_{IN,MAX}} \right) \quad (14)$$

Substituting $V_{OUT}=2.5V$, $V_{IN,MAX}=12V$, $\Delta I_{L,MAX}=0.4A$, and $f_S = 370kHz$ in the formula gives:

$$L = \frac{2.5}{370kHz(0.4A)} \left(1 - \frac{2.5}{12} \right) = 13\mu H \quad (15)$$

A 15 μH inductor is chosen for this application.

If the V_{OUT} voltage is 2.5V, choose $R_2=18k\Omega$ (1%), and R_3 can be calculated from:

$$R_3 = 18k\Omega \left(\frac{0.6}{2.5 - 0.6} \right) = 5.68k\Omega \quad (16)$$

Choose $R_3=5.6k\Omega$ (1%).

In this application, with the desired crossover frequency at 30kHz, R_C value is calculated as follows:

$$R_C = \frac{2\pi \cdot 22\mu F \cdot 30kHz \cdot 2.5V}{2A/V \cdot 380\mu A/V \cdot 0.6V} \quad (17)$$

If $R_C=22.72k\Omega$, choose 22k Ω for the design.

If $R_C=22k\Omega$, use the following equation to get C_C :

$$C_C = \frac{2}{\pi \cdot 22k\Omega \cdot 30kHz} \quad (18)$$

$C_C=0.965nF$, choose 1nF for the design.

Table 1. Recommended Compensation Values ($V_{IN}=12V$)

V_O	L	C_{OUT}	R_2	R_3	R_C	C_C
1.8V	10 μH	22 μF MLCC	18k Ω	9k Ω	16k Ω	1.5nF
2.5V	15 μH			5.6k Ω	22k Ω	1nF
3.3V	15 μH			4k Ω	27k Ω	820pF
5V	22 μH			2.45k Ω	43k Ω	560pF

Layout Consideration

As with all switching power supplies, careful attention to PCB layout is important to the design. A few design rules should be implemented to ensure good layout:

- Keep the high-current traces and load connections as short as possible.
- Place the input capacitor, the inductor, the freewheeling diode, and the output capacitor as close as possible to the IC terminals.
- Keep the loop area between the SW node, freewheeling diode, inductor, and output capacitor as small as possible. Minimizing ground loops reduces EMI issues.
- Route high-dV/dt signals, such as SW node, away from the error amplifier input/output pins. Keep components connected to these pins close to the pins.
- To effectively remove heat from the MOSFETs, use wide land areas with appropriate thermal vias.

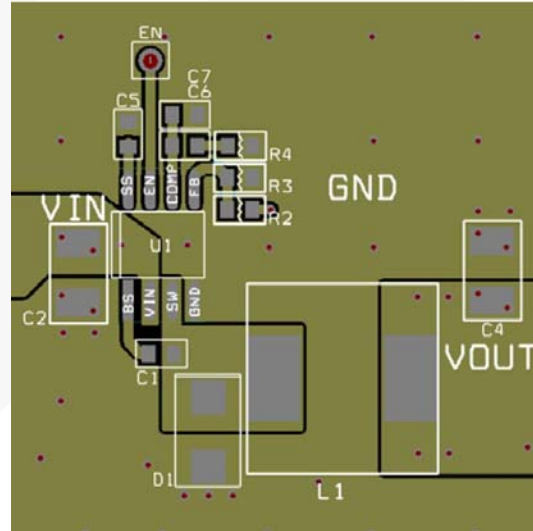

Figure 17. Recommended PCB Layout

Physical Dimensions

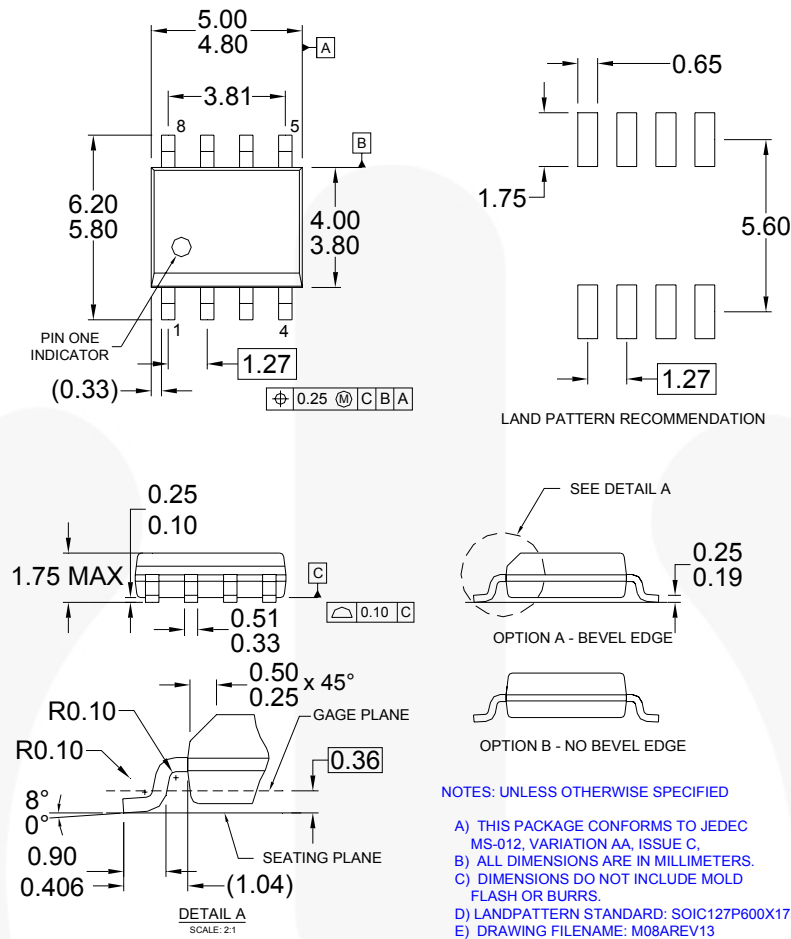

Figure 18.8-Lead, Small Outline Integrated Circuit (SOIC-8)

Dimensions

Symbol	Millimeter			Inch		
	Min.	Typ.	Max.	Min.	Typ.	Max.
A	1.346		1.752	0.053		0.069
A1	0.101		0.254	0.004		0.010
b		0.406			0.016	
c		0.203			0.008	
D	4.648		4.978	0.183		0.196
E	3.810		3.987	0.150		0.157
e		1.270			0.050	
F		0.381X45°			0.015X45°	
H	5.791		6.197	0.228		0.244
L	0.406		1.270	0.016		0.050
θ°	0°		8°	0°		8°

Package drawings are provided as a service to customers considering Fairchild components. Drawings may change in any manner without notice. Please note the revision and/or date on the drawing and contact a Fairchild Semiconductor representative to verify or obtain the most recent revision. Package specifications do not expand the terms of Fairchild's worldwide terms and conditions, specifically the warranty therein, which covers Fairchild products.

Always visit Fairchild Semiconductor's online packaging area for the most recent package drawings:
<http://www.fairchildsemi.com/packaging/>.





TRADEMARKS

The following includes registered and unregistered trademarks and service marks, owned by Fairchild Semiconductor and/or its global subsidiaries, and is not intended to be an exhaustive list of all such trademarks.

Build it Now™
CorePLUS™
CorePOWER™
CROSSVOLT™
CTL™
Current Transfer Logic™
EcoSPARK®
EfficientMax™
EZSWITCH™ *
™
®
Fairchild®
Fairchild Semiconductor®
FACT Quiet Series™
FACT®
FAST®
FastvCore™
FlashWriter® *
FPS™
F-PFS™

FRFET®
Global Power Resource™
Green FPST™
Green FPS™ e-Series™
GTO™
IntelliMAX™
ISOPLANAR™
MegaBuck™
MICROCOUPLER™
MicroFET™
MicroPak™
MillerDrive™
MotionMax™
Motion-SPM™
OPTOLOGIC®
OPTOPLANAR®
®
PDP SPM™
Power-SPM™
PowerTrench®
PowerXS™

Programmable Active Droop™
QFET®
QS™
Quiet Series™
RapidConfigure™
™
Saving our world, 1mW/W/kW at a time™
SmartMax™
SMART START™
SPM®
STEALTH™
SuperFET™
SuperSOT™.3
SuperSOT™.6
SuperSOT™.8
SupreMOS™
SyncFET™
 SYSTEM GENERAL
The Power Franchise®

™
TinyBoost™
TinyBuck™
TinyLogic®
TINYOPTO™
TinyPower™
TinyPWM™
TinyWire™
µSerDes™
 SerDes™
UHC®
Ultra FRFET™
UniFET™
VCX™
VisualMax™
XS™

* EZSWITCH™ and FlashWriter® are trademarks of System General Corporation, used under license by Fairchild Semiconductor.

DISCLAIMER

FAIRCHILD SEMICONDUCTOR RESERVES THE RIGHT TO MAKE CHANGES WITHOUT FURTHER NOTICE TO ANY PRODUCTS HEREIN TO IMPROVE RELIABILITY, FUNCTION, OR DESIGN. FAIRCHILD DOES NOT ASSUME ANY LIABILITY ARISING OUT OF THE APPLICATION OR USE OF ANY PRODUCT OR CIRCUIT DESCRIBED HEREIN; NEITHER DOES IT CONVEY ANY LICENSE UNDER ITS PATENT RIGHTS, NOR THE RIGHTS OF OTHERS. THESE SPECIFICATIONS DO NOT EXPAND THE TERMS OF FAIRCHILD'S WORLDWIDE TERMS AND CONDITIONS, SPECIFICALLY THE WARRANTY THEREIN, WHICH COVERS THESE PRODUCTS.

LIFE SUPPORT POLICY

FAIRCHILD'S PRODUCTS ARE NOT AUTHORIZED FOR USE AS CRITICAL COMPONENTS IN LIFE SUPPORT DEVICES OR SYSTEMS WITHOUT THE EXPRESS WRITTEN APPROVAL OF FAIRCHILD SEMICONDUCTOR CORPORATION.

As used herein:

1. Life support devices or systems are devices or systems which, (a) are intended for surgical implant into the body or (b) support or sustain life, and (c) whose failure to perform when properly used in accordance with instructions for use provided in the labeling, can be reasonably expected to result in a significant injury of the user.
2. A critical component in any component of a life support, device, or system whose failure to perform can be reasonably expected to cause the failure of the life support device or system, or to affect its safety or effectiveness.

ANTI-COUNTERFEITING POLICY

Fairchild Semiconductor Corporation's Anti-Counterfeiting Policy. Fairchild's Anti-Counterfeiting Policy is also stated on our external website, www.fairchildsemi.com, under Sales Support.

Counterfeiting of semiconductor parts is a growing problem in the industry. All manufacturers of semiconductor products are experiencing counterfeiting of their parts. Customers who inadvertently purchase counterfeit parts experience many problems such as loss of brand reputation, substandard performance, failed applications, and increased cost of production and manufacturing delays. Fairchild is taking strong measures to protect ourselves and our customers from the proliferation of counterfeit parts. Fairchild strongly encourages customers to purchase Fairchild parts either directly from Fairchild or from Authorized Fairchild Distributors who are listed by country on our web page cited above. Products customers buy either from Fairchild directly or from Authorized Fairchild Distributors are genuine parts, have full traceability, meet Fairchild's quality standards for handling and storage and provide access to Fairchild's full range of up-to-date technical and product information. Fairchild and our Authorized Distributors will stand behind all warranties and will appropriately address any warranty issues that may arise. Fairchild will not provide any warranty coverage or other assistance for parts bought from Unauthorized Sources. Fairchild is committed to combat this global problem and encourage our customers to do their part in stopping this practice by buying direct or from authorized distributors.

PRODUCT STATUS DEFINITIONS

Definition of Terms

Datasheet Identification	Product Status	Definition
Advance Information	Formative / In Design	Datasheet contains the design specifications for product development. Specifications may change in any manner without notice.
Preliminary	First Production	Datasheet contains preliminary data; supplementary data will be published at a later date. Fairchild Semiconductor reserves the right to make changes at any time without notice to improve design.
No Identification Needed	Full Production	Datasheet contains final specifications. Fairchild Semiconductor reserves the right to make changes at any time without notice to improve the design.
Obsolete	Not In Production	Datasheet contains specifications on a product that is discontinued by Fairchild Semiconductor. The datasheet is for reference information only.

Rev. I37