



Illum.push-but.conic.green,inscript.



Powering Business Worldwide™



**Part no.**  
**Article no.**  
**Catalog No.**

**M22-DLH-G-X1**  
**216977**  
**M22-DLH-G-X1Q**

## Delivery programme

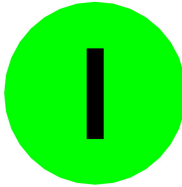

Product range			RMQ-Titan (drilling dimensions 22.5 mm)
Basic function			Illuminated pushbutton actuators
Single unit/Complete unit			Single unit
Design			Extended
Function			momentary
Colour			
Button plate			
Protection type			IP67, IP69K
Front ring			Front ring: titanium
Connection to SmartWire-DT			yes

## Approvals

Product Standards  
UL File No.  
UL Category Control No.  
CSA File No.  
CSA Class No.  
North America Certification  
Degree of Protection

IEC/EN 60947-5; UL 508; CSA-C22.2 No. 14-05; CSA-C22.2 No. 94-91; CE marking  
E29184  
NKCR  
012528  
3211-03  
UL listed, CSA certified  
UL/CSA Type 3R, 4X, 12, 13

## General

Standards			IEC/EN 60947 VDE 0660
Lifespan, mechanical	Operations	x 10 <sup>6</sup>	> 5
Operating frequency	Operations/ h		 3600
Actuating force		n	 5
Protection type			IP67, IP69K
Climatic proofing			Damp heat, constant, to IEC 60068-2-78 Damp heat, cyclic, to IEC 60068-2-30
Ambient temperature		°C	
Open		°C	- 25 - + 70
Mounting position			As required
Mechanical shock resistance		g	30 Shock duration 11 ms Sinusoidal according to IEC 60068-2-27

## Technical data ETIM 5.0

Low-voltage industrial components (EG000017) / Front element for push button (EC000221)  
Electric engineering, automation, process control engineering / Low-voltage switch technology / Command and alarm device / Front element for push-button actuators  
(ecl@ss8-27-37-12-10 [AKF028010])

Colour button			Green
Number of command positions			1
Construction type lens			Round
Hole diameter		mm	22
Width opening		mm	22
Height meter opening		mm	6
Degree of protection (IP), front side			IP67
Type of button			High

Suitable for illumination		Yes
Switching function latching		No
Spring-return		Yes
With front ring		Yes
Material front ring		Plastic
Colour front ring		Chrome

## Dimensions

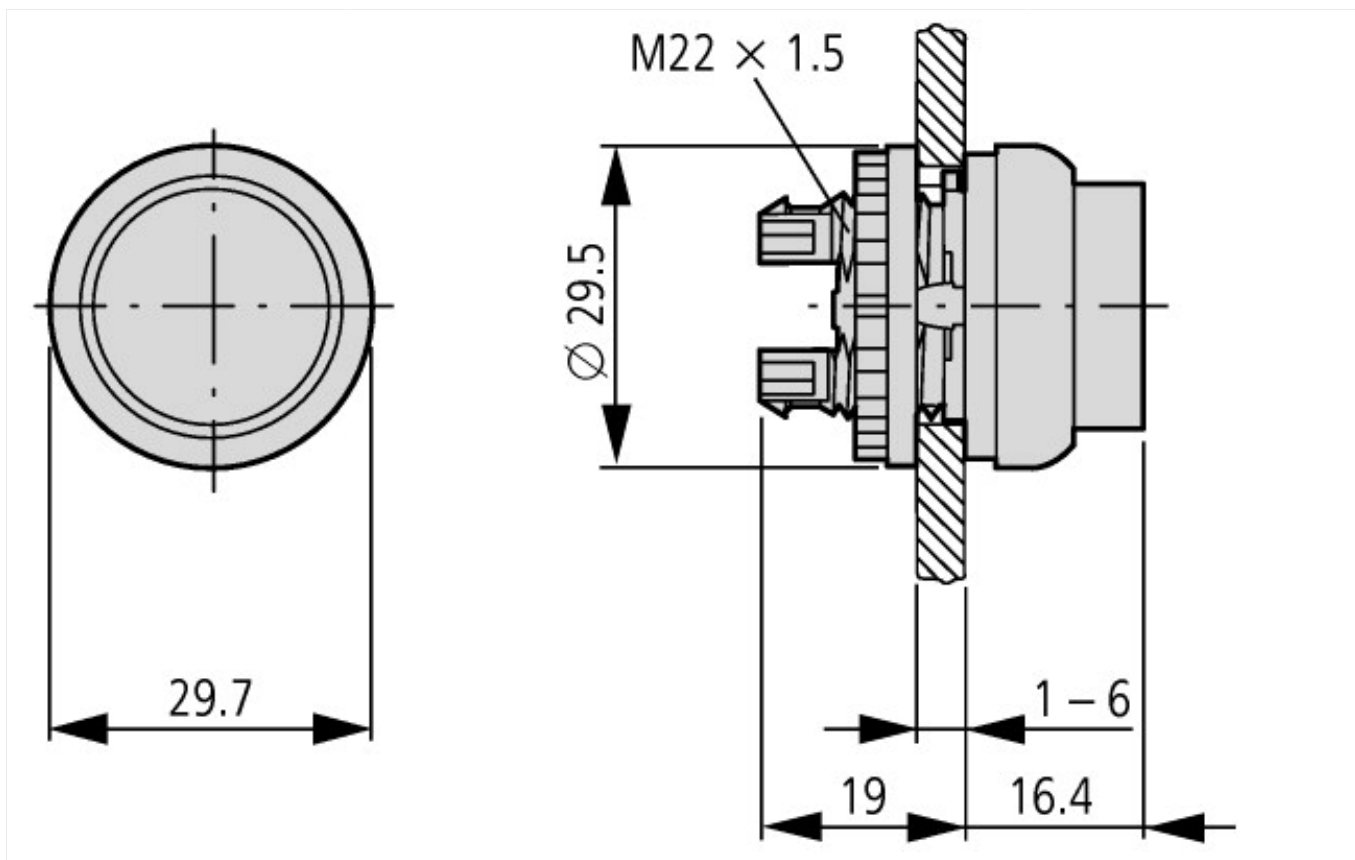

## Additional product information (links)

**IL04716002Z (AWA1160-1745) RMQ-Titan System**

IL04716002Z (AWA1160-1745) RMQ-Titan System

[ftp://ftp.moeller.net/DOCUMENTATION/AWA\\_INSTRUCTIONS/IL04716002Z2013\\_08.pdf](ftp://ftp.moeller.net/DOCUMENTATION/AWA_INSTRUCTIONS/IL04716002Z2013_08.pdf)