

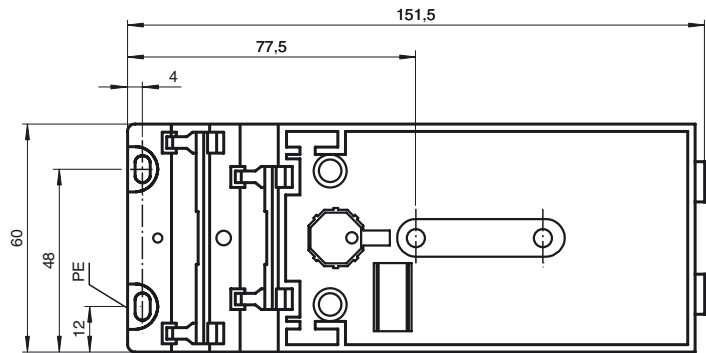

Dimensions



Model Number

U-G2FF

AS-Interface module mounting base for connection to flat cable (AS-Interface and external auxiliary power)

Function

The U-G2FF base is used for the connection of the G2 modules with long design to AS-Interface. In case of mounting the module the inserted flat cables are pressed into the contact prongs of the module and connected. For some modules this upper part establishes the connection to earth.

Test-fuer-tabsepattrib

Connection cable

VBA-4E3A-G2-ZA/EA2

AS-Interface sensor/actuator module

VAA-4E4A-G2-ZA/EA2

AS-Interface sensor/actuator module

VBA-4E2A-G2-ZA/EA2-Ex

AS-Interface sensor/actuator module

VBA-4E4A-G2-ZA/EA2

AS-Interface sensor/actuator module

VBA-4E3A-G2-ZA0/EA0

AS-Interface sensor/actuator module

VBA-8E-G2-ZA

AS-Interface sensor module

VAA-4EA-G2-ZE/E2

AS-Interface sensor/actuator module

TESTPRODUKT VBA

Test data sheet

Technical data

Ambient conditions

Ambient temperature	-25 ... 60 °C (248 ... 333 K)
Storage temperature	-25 ... 85 °C (248 ... 358 K)

Mechanical specifications

Protection degree	IP67 according to EN 60529 (only in connection with module or cover)
Connection	AS-Interface flat cable
Material	
Housing	PBT
Dimensions	about 80, 45, 34 mm (L, W, H)

Notes

Do not connect inputs and outputs, which are supplied via the module from AS-interface or via auxiliary power, with power supply and signal circuits with external potentials.