

OV5653 5-megapixel product brief



available in
a lead-free
package

Best In Class Still Capture and 1080p Full HD Digital Video

Introducing the OV5653, OmniVision's latest 5-megapixel imaging solution for digital still camera (DSC) and digital video (DV) applications, featuring 1.75 μm OmniBSI™ (backside illumination) technology. OmniBSI technology delivers a number of performance improvements over front-side illumination (FSI) technology, including increased sensitivity per unit area, improved quantum efficiency, reduced crosstalk and photo response non-uniformity, which all lead to significant improvements in image quality.

The OV5653 delivers the industry's best low-light sensitivity of $>1300 \text{ mV/lux-sec}$ – a 40 percent improvement over previous FSI devices – and a 2x improvement in signal-to-noise ratio ($<70 \text{ lux}$). Ideal for both 5-megapixel DSC and DV applications, the OV5653 delivers 720p at 60 frames per second (fps) and full HD 1080p at 30 fps, resulting in vivid still and video images, even in the most challenging lighting conditions.

Although the OV5653 is a RAW sensor, it includes a variety of automatic image control functions such as automatic exposure control, automatic 50/60 Hz luminance detection, and auto black level calibration.

The OV5653 also includes programmable user controls for image quality, formatting and output data transfer, mirror and flip, cropping, windowing and panning. 256 bytes of embedded one-time programmable memory provide storage for custom information such as calibration parameters.

The OV5653 offers support for horizontal and vertical sub-sampling, and 2 x 2 binning. The embedded 1.5 volt regulator eliminates the need for additional power components.

The OV5653 – simply the best 5-megapixel solution in its class. Find out more at www.ovt.com.

Applications

- Digital Still and Video Cameras
- Security Cameras

Product Features

- 1.75 μm OmniBSI™ technology for high performance (high sensitivity, low crosstalk, low noise)
- industry's best low light sensitivity
- 720p at 60 fps and full HD 1080p at 30 fps
- 256 bytes of embedded one-time programmable (OTP) memory
- support for horizontal and vertical sub-sampling and 2 x 2 binning
- image quality controls: lens shading correction, 2-D defective pixel cancelling
- support for output formats: 8/10-bit RAW RGB data
- support for video or snapshot operations
- support for internal and external frame synchronization for frame exposure mode
- standard serial SCCB interface
- digital video port (DVP) parallel output interface
- MIPI interface (two lanes)
- on-chip phase lock loop (PLL)
- embedded 1.5 V regulator for core power
- programmable I/O drive capability, I/O tri-state configurability
- support for black sun cancellation
- programmable controls for frame rate, AEC/AGC 16-zone size/position/weight control, mirror and flip, cropping, windowing, and panning

OV5653

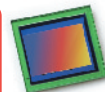

Ordering Information

- OV05653-A66A (color, lead-free, 66-pin CSP3)

Product Specifications

- active array size: 2592 x 1944
- S/N ratio: 37 dB
- power supply:
 - core: 1.5 V \pm 5% (with embedded 1.5 V regulator)
 - analog: 2.6 - 3.0 V (2.8 V typical)
 - I/O: 1.8 V/2.8 V
- power requirements:
 - active: 150 mA
 - standby: 40 μA
- temperature range:
 - operating: -30°C to 70°C
 - stable image: 0°C to 50°C
- output formats: 8/10-bit RAW RGB output
- lens size: 1/3.2"
- lens chief ray angle: 11.2° non-linear
- input clock frequency: 6 - 27 MHz
- dynamic range: 69 dB
- maximum image transfer rate:
 - QSXGA (2592x1944): 15 fps
 - 1080p: 30 fps
 - 720p: 60 fps
 - VGA (640x480): 90 fps
 - QVGA (320x240): 120 fps
- sensitivity: >1300 mV/lux-sec
- shutter: rolling shutter
- pixel size: 1.75 μm x 1.75 μm
- well capacity: 7.5 Ke⁻
- dark current: <8 mV/sec @ 50°C
- image area: 4592 μm x 3423 μm
- package dimensions: 6505 μm x 6005 μm

Functional Block Diagram

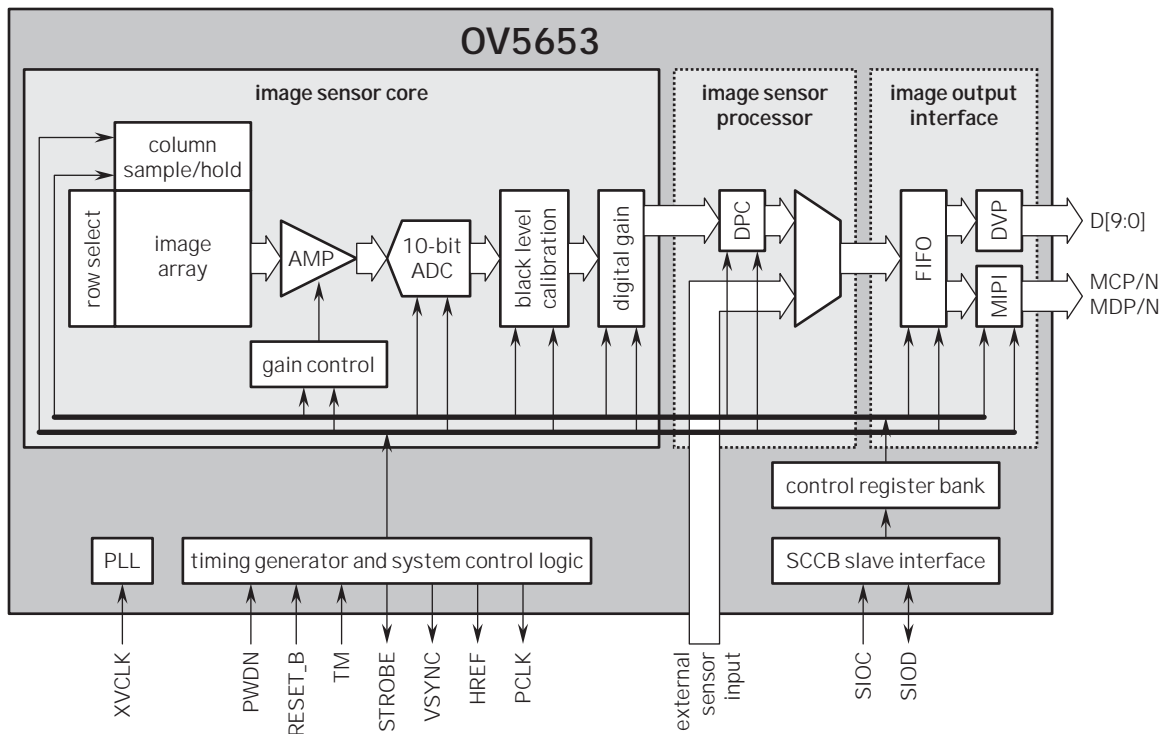

4275 Burton Drive
Santa Clara, CA 95054
USA

Tel: + 1 408 567 3000
Fax: + 1 408 567 3001
www.ovt.com

OmniVision reserves the right to make changes to their products or to discontinue any product or service without further notice. OmniVision and the OmniVision logo are registered trademarks of OmniVision Technologies, Inc. OmniBSI is a trademark of OmniVision Technologies, Inc. All other trademarks are the property of their respective owners.

OmniVision