

Standard SMD LED PLCC-2

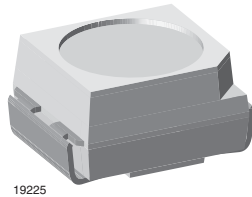

19225

DESCRIPTION

This device has been designed to meet the increasing demand for white SMD LED.

The package of the VLMW41.. is the PLCC-2.

It consists of a lead frame which is embedded in a white thermoplast. The reflector inside this package is filled with a mixture of epoxy and TAG phosphor.

The TAG phosphor converts the blue emission partially to yellow, which mixes with the remaining blue to give white.

PRODUCT GROUP AND PACKAGE DATA

- Product group: LED
- Package: SMD PLCC-2
- Product series: standard
- Angle of half intensity: $\pm 60^\circ$

FEATURES

- High efficient InGaN technology
- Very narrow chromaticity coordinate group categorization according to CIE1931 per packing unit
- Typical color temperature 5500 K
- EIA and ICE standard package
- Compatible with reflow, vapor phase and wave solder processes acc. to CECC 00802 and J-STD-020
- Available in 8 mm tape reel
- Preconditioning: according to JEDEC level 2a
- ESD-withstand voltage: up to 2 kV according to JESD22-A114-B
- Compliant to RoHS Directive 2002/95/EC and in accordance to WEEE 2002/96/EC
- AEC-Q101 qualified

RoHS
COMPLIANT

GREEN
(5-2008)**

APPLICATIONS

- Camera flash light
- Signal and symbol luminaire
- Marker lights
- Interior and exterior automotive lighting: brake lights, turn lights, backlighting, side markers
- Indicator lighting

PARTS TABLE

PART	COLOR, LUMINOUS INTENSITY	CHROMATICITY COORDINATES	TECHNOLOGY
VLMW41S1T2-JKPL-08	White, $I_V = (180 \text{ to } 450) \text{ mcd}$	x/y typ.: 0.33/0.33	InGaN/Sapphire and TAG
VLMW41S1T2-JKPL-18	White, $I_V = (180 \text{ to } 450) \text{ mcd}$	x/y typ.: 0.33/0.33	InGaN/Sapphire and TAG
VLMW41S1T2-JKLL-08	White, $I_V = (180 \text{ to } 450) \text{ mcd}$	x/y typ.: 0.30/0.28	InGaN/Sapphire and TAG
VLMW41S1T2-KKLL-08	White, $I_V = (180 \text{ to } 450) \text{ mcd}$	x/y typ.: 0.31/0.30	InGaN/Sapphire and TAG
VLMW41S1T2-LKML-08	White, $I_V = (180 \text{ to } 450) \text{ mcd}$	x/y typ.: 0.32/0.31	InGaN/Sapphire and TAG
VLMW41S1T2-LKML-18	White, $I_V = (180 \text{ to } 450) \text{ mcd}$	x/y typ.: 0.32/0.31	InGaN/Sapphire and TAG
VLMW41S1T2-MKNL-08	White, $I_V = (180 \text{ to } 450) \text{ mcd}$	x/y typ.: 0.33/0.33	InGaN/Sapphire and TAG
VLMW41S1T2-NKOL-08	White, $I_V = (180 \text{ to } 450) \text{ mcd}$	x/y typ.: 0.34/0.34	InGaN/Sapphire and TAG
VLMW41S1T2-OKPL-08	White, $I_V = (180 \text{ to } 450) \text{ mcd}$	x/y typ.: 0.35/0.36	InGaN/Sapphire and TAG

** Please see document "Vishay Material Category Policy": www.vishay.com/doc?99902

ABSOLUTE MAXIMUM RATINGS ($T_{amb} = 25\text{ }^{\circ}\text{C}$, unless otherwise specified)
VLMW41..

PARAMETER	TEST CONDITION	SYMBOL	VALUE	UNIT
DC forward current	$T_{amb} \leq 80\text{ }^{\circ}\text{C}$	I_F	20	mA
Surge forward current	$t_p \leq 10\text{ }\mu\text{s}$	I_{FSM}	0.1	A
Power dissipation		P_V	84	mW
Junction temperature		T_j	110	$^{\circ}\text{C}$
Storage temperature range		T_{stg}	- 40 to + 100	$^{\circ}\text{C}$
Operating temperature range		T_{amb}	- 40 to + 100	$^{\circ}\text{C}$
Thermal resistance junction/ ambient	Mounted on PC board (pad size > 16 mm ²)	R_{thJA}	360	K/W

OPTICAL AND ELECTRICAL CHARACTERISTICS ($T_{amb} = 25\text{ }^{\circ}\text{C}$, unless otherwise specified)
VLMW41.., WHITE

PARAMETER	TEST CONDITION	PART	SYMBOL	MIN.	TYP.	MAX.	UNIT
Luminous intensity	$I_F = 10\text{ mA}$	VLMW41S1T2	I_V	180		450	mcd
Chromaticity coordinates acc. to CIE 1931	$I_F = 10\text{ mA}$	VLMW41S1T2-JKPL	x/y		0.33/0.33		
		VLMW41S1T2-JKKL			0.30/0.28		
		VLMW41S1T2-KKLL			0.31/0.30		
		VLMW41S1T2-LKML			0.32/0.31		
		VLMW41S1T2-MKNL			0.33/0.33		
		VLMW41S1T2-NKOL			0.34/0.34		
		VLMW41S1T2-OKPL			0.35/0.36		
Angle of half intensity	$I_F = 10\text{ mA}$		φ		± 60		deg
Forward voltage	$I_F = 20\text{ mA}$		V_F	2.7	3.3	4.2	V
Temperature coefficient of V_F	$I_F = 10\text{ mA}$		TC_{VF}		- 3		mV/K
Temperature coefficient of I_V	$I_F = 10\text{ mA}$		TC_{IV}		- 0.4		%/K

Note:

Not designed for reverse operation

LUMINOUS INTENSITY CLASSIFICATION

GROUP	LIGHT INTENSITY (mcd)		
	OPTIONAL	MIN.	MAX.
S	1	180	224
	2	224	280
T	1	280	355
	2	355	450

Note:

Luminous intensity is tested at a current pulse duration of 25 ms and an accuracy of $\pm 11\%$.

The above type numbers represent the order groups which include only a few brightness groups. Only one group will be shipped on each reel (there will be no mixing of two groups on each reel). In order to ensure availability, single brightness groups are not be orderable.

In a similar manner for colors where wavelength groups are measured and binned, single wavelength groups will be shipped on any one reel.

In order to ensure availability, single wavelength groups are not be orderable.

CROSSING TABLE

VISHAY	OSRAM
VLMW41..	LWT67C..

CHROMATICITY COORDINATED GROUPS FOR WHITE SMD LED					
	X	Y		X	Y
JK	0.2960	0.2590	ML	0.3189	0.3302
	0.2910	0.2680		0.3288	0.3452
	0.3005	0.2825		0.3288	0.3282
	0.3045	0.2715		0.3197	0.3131
JL	0.2910	0.2680	NK	0.3288	0.3081
	0.2850	0.2790		0.3288	0.3282
	0.2960	0.2955		0.3386	0.3426
	0.3005	0.2825		0.3386	0.3235
KK	0.3045	0.2715	NL	0.3288	0.3282
	0.3005	0.2825		0.3288	0.3453
	0.3100	0.2970		0.3386	0.3591
	0.3130	0.2840		0.3386	0.3426
KL	0.3005	0.2825	OK	0.3386	0.3235
	0.2960	0.2955		0.3386	0.3426
	0.3070	0.3120		0.3484	0.3571
	0.3100	0.2970		0.3484	0.3388
LK	0.3100	0.2970	OL	0.3386	0.3426
	0.3197	0.3131		0.3386	0.3591
	0.3205	0.2956		0.3484	0.3730
	0.3130	0.2840		0.3484	0.3571
LL	0.3070	0.3120	PK	0.3484	0.3388
	0.3189	0.3302		0.3484	0.3571
	0.3197	0.3131		0.3582	0.3715
	0.3100	0.2970		0.3582	0.3542
MK	0.3197	0.3131	PL	0.3484	0.3571
	0.3288	0.3282		0.3484	0.3730
	0.3288	0.3081		0.3582	0.3792
	0.3205	0.2956		0.3582	0.3715

Note:

Chromaticity coordinate groups are tested at a current pulse duration of 25 ms and a tolerance of ± 0.01 .

TYPICAL CHARACTERISTICS ($T_{amb} = 25\text{ }^{\circ}\text{C}$, unless otherwise specified)

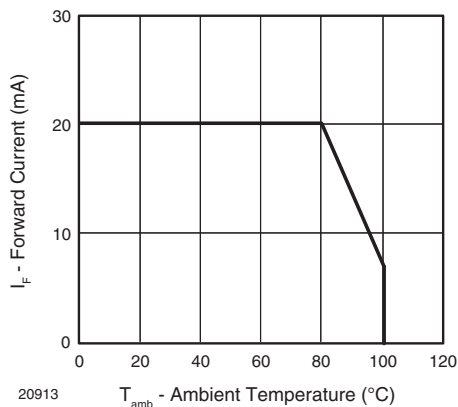

Figure 1. Forward Current vs. Ambient Temperature

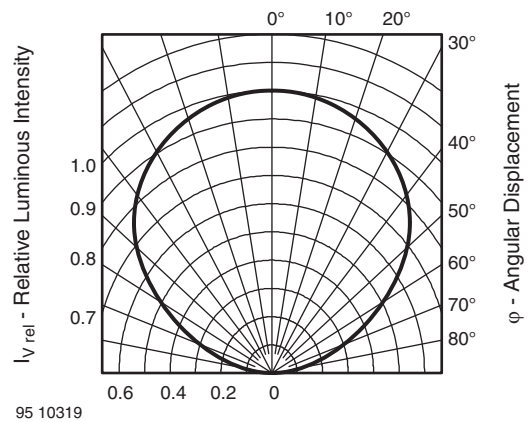

Figure 2. Rel. Luminous Intensity vs. Angular Displacement

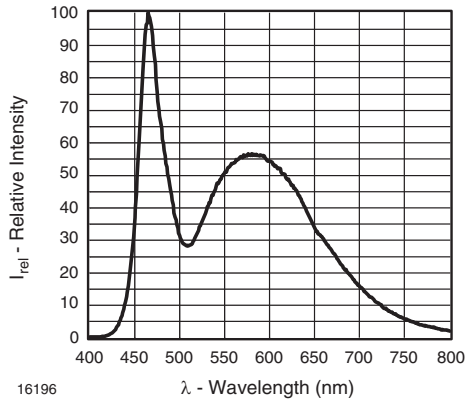

Figure 3. Relative Intensity vs. Wavelength

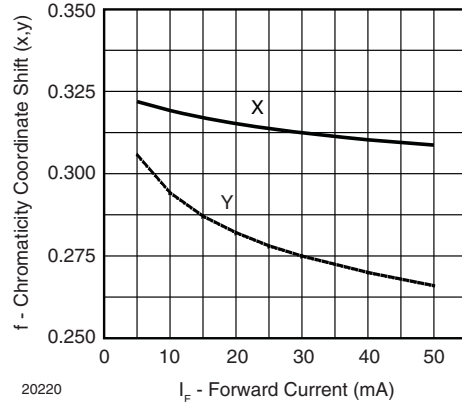

Figure 6. Chromaticity Coordinate Shift vs. Forward Current

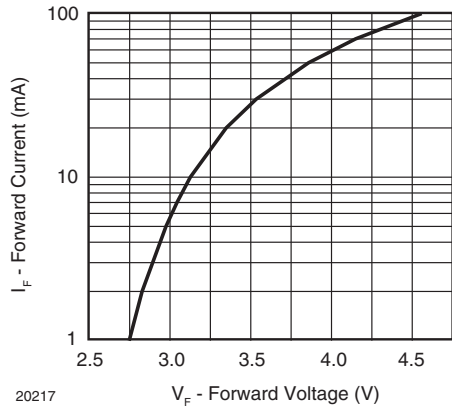

Figure 4. Forward Current vs. Forward Voltage

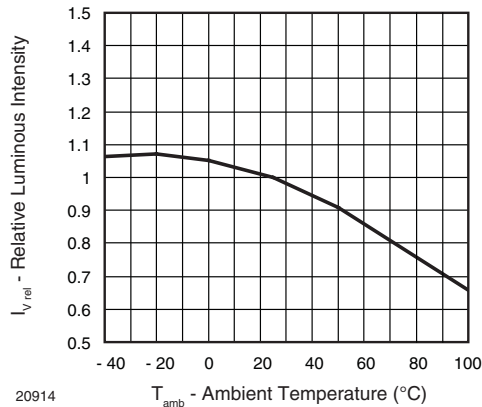

Figure 7. Rel. Luminous Intensity vs. Ambient Temperature

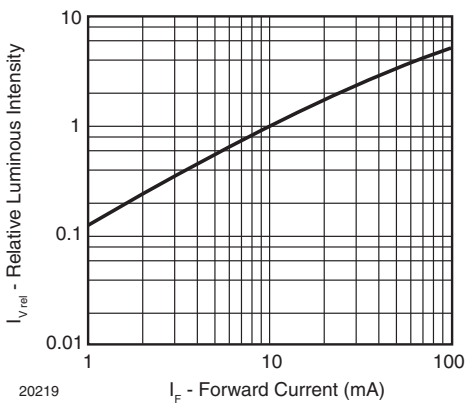

Figure 5. Relative Luminous Intensity vs. Forward Current

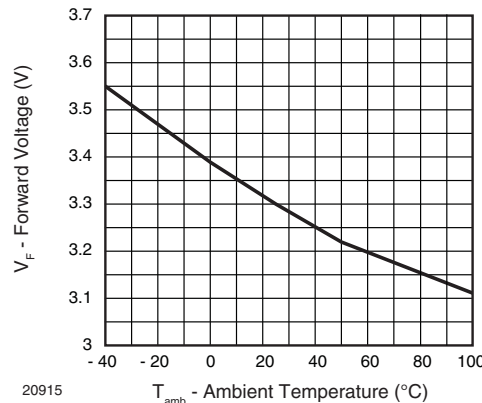

Figure 8. Forward Voltage vs. Ambient Temperature

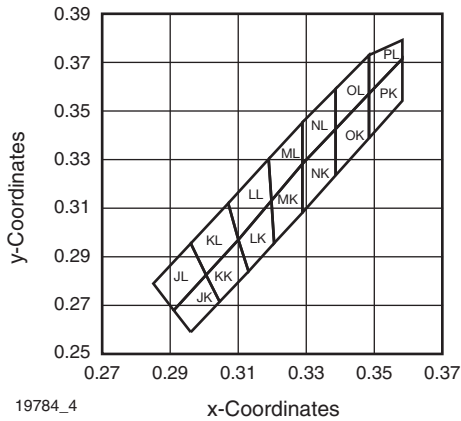
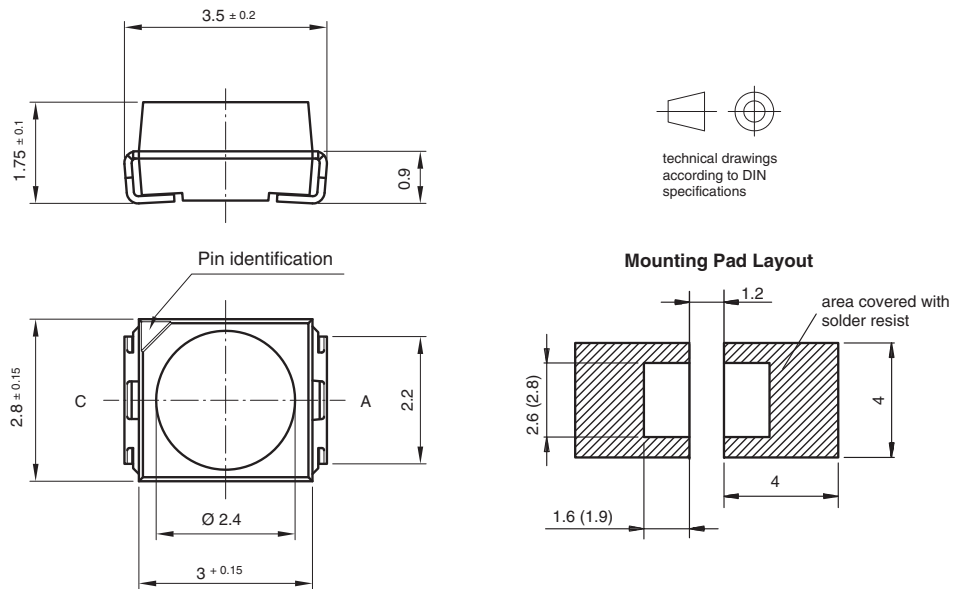
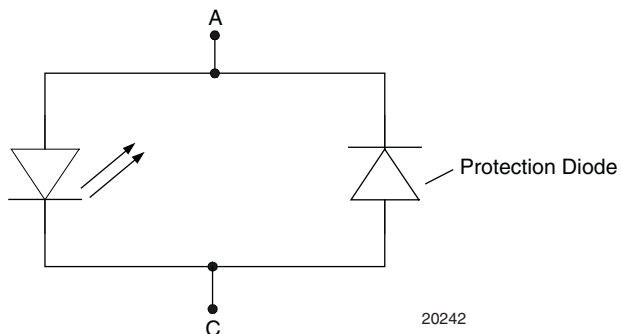

Figure 9. Coordinates of Colorgroups

PACKAGE DIMENSIONS in millimeters



Drawing-No.: 6.541-5089.01-4
Issue: 1; 10.06.10
22174



20242

METHOD OF TAPING/POLARITY AND TAPE AND REEL

SMD LED (VLM.3.../.4... - SERIES)

Vishay's LEDs in SMD packages are available in an antistatic 8 mm blister tape (in accordance with DIN IEC 40 (CO) 564) for automatic component insertion. The blister tape is a plastic strip with impressed component cavities, covered by a top tape.

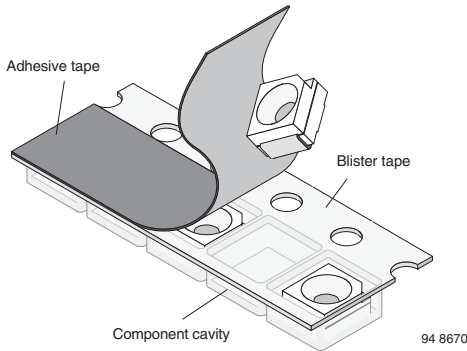

TAPING OF VLM.3.../.4...

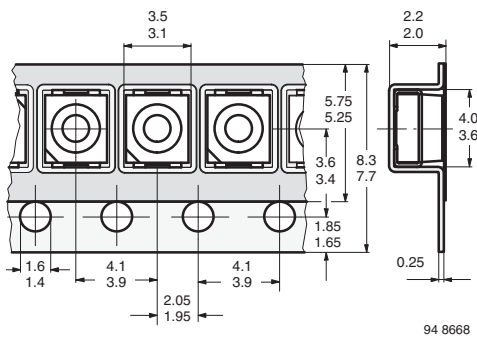

Figure 10. Tape Dimensions in mm for PLCC-2

REEL PACKAGE DIMENSION IN MILLIMETERS FOR SMD LEDs, TAPE OPTION GS08 (= 1500 PCS.)

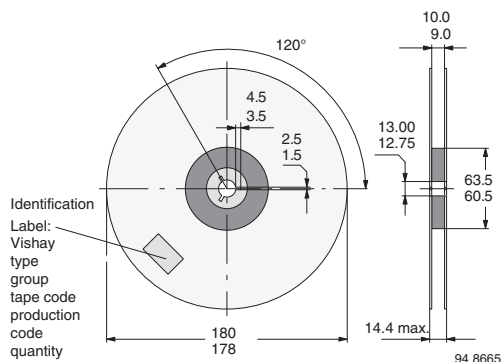

Figure 11. Reel Dimensions - GS08

REEL PACKAGE DIMENSION IN MILLIMETERS FOR SMD LEDs, TAPE OPTION GS18 (= 8000 PCS.) PREFERRED

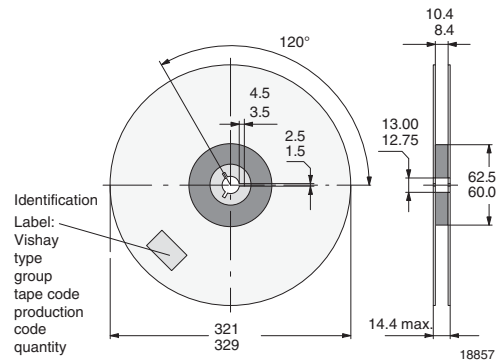

Figure 12. Reel Dimensions - GS18

SOLDERING PROFILE

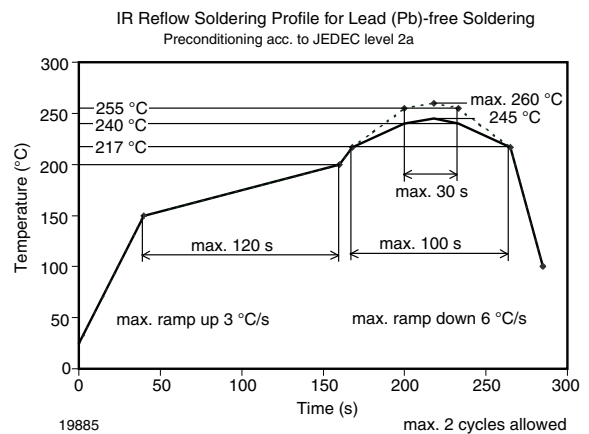

Figure 13. Vishay Lead (Pb)-free Reflow Soldering Profile (acc. to J-STD-020)

6

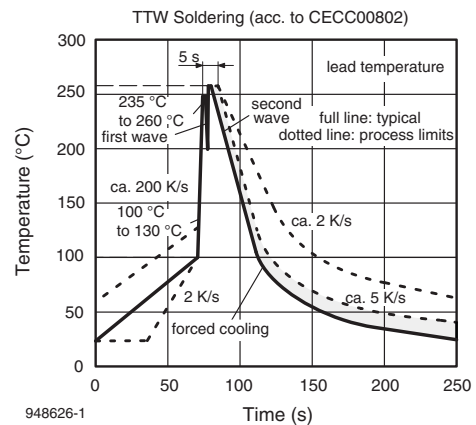
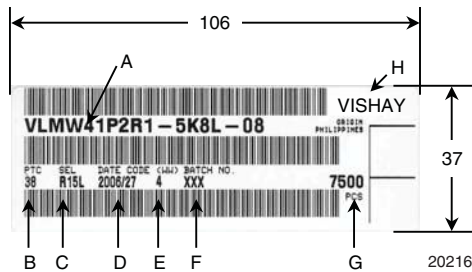

Figure 14. Double Wave Soldering of Opto Devices (all Packages)

**BAR CODE PRODUCT LABEL
EXAMPLE:**



- A) Type of component
- B) Manufacturing plant
- C) SEL - selection code (bin):
e.g.: R1 = code for luminous intensity group
5L = code for chrom. coordinate group
- D) Date code year/week
- E) Day code (e.g. 4: Thursday)
- F) Batch no.
- G) Total quantity
- H) Company code

DRY PACKING

The reel is packed in an anti-humidity bag to protect the devices from absorbing moisture during transportation and storage.

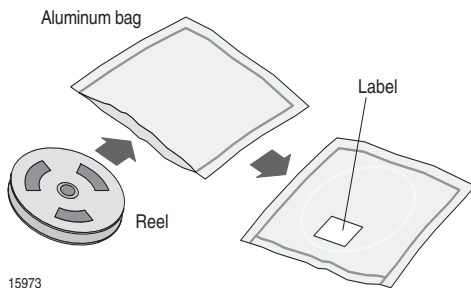

FINAL PACKING

The sealed reel is packed into a cardboard box. A secondary cardboard box is used for shipping purposes.

RECOMMENDED METHOD OF STORAGE

Dry box storage is recommended as soon as the aluminum bag has been opened to prevent moisture absorption. The following conditions should be observed, if dry boxes are not available:

- Storage temperature 10 °C to 30 °C
- Storage humidity ≤ 60 % RH max.

After more than 672 h under these conditions moisture content will be too high for reflow soldering.

In case of moisture absorption, the devices will recover to the former condition by drying under the following condition:

- 192 h at 40 °C + 5 °C/- 0 °C and < 5 % RH (dry air/nitrogen) or
- 96 h at 60 °C + 5 °C and < 5 % RH for all device containers or
- 24 h at 100 °C + 5 °C not suitable for reel or tubes.

An EIA JEDEC standard JESD22-A112 level 2a label is included on all dry bags.

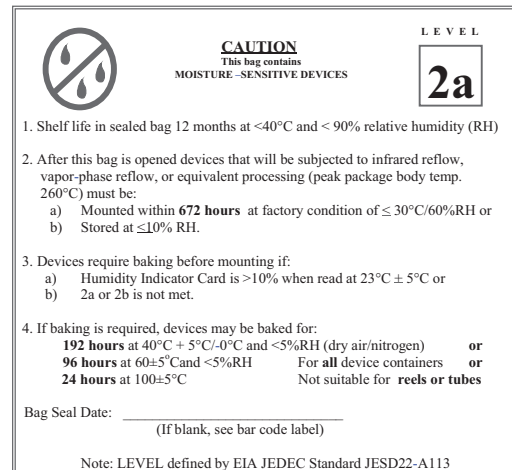

Example of JESD22-A112 level 2a label

ESD PRECAUTION

Proper storage and handling procedures should be followed to prevent ESD damage to the devices especially when they are removed from the antistatic shielding bag. Electro-static sensitive devices warning labels are on the packaging.

**VISHAY SEMICONDUCTORS STANDARD
BAR CODE LABELS**

The Vishay Semiconductors standard bar code labels are printed at final packing areas. The labels are on each packing unit and contain Vishay Semiconductors specific data.



Disclaimer

ALL PRODUCT, PRODUCT SPECIFICATIONS AND DATA ARE SUBJECT TO CHANGE WITHOUT NOTICE TO IMPROVE RELIABILITY, FUNCTION OR DESIGN OR OTHERWISE.

Vishay Intertechnology, Inc., its affiliates, agents, and employees, and all persons acting on its or their behalf (collectively, "Vishay"), disclaim any and all liability for any errors, inaccuracies or incompleteness contained in any datasheet or in any other disclosure relating to any product.

Vishay makes no warranty, representation or guarantee regarding the suitability of the products for any particular purpose or the continuing production of any product. To the maximum extent permitted by applicable law, Vishay disclaims (i) any and all liability arising out of the application or use of any product, (ii) any and all liability, including without limitation special, consequential or incidental damages, and (iii) any and all implied warranties, including warranties of fitness for particular purpose, non-infringement and merchantability.

Statements regarding the suitability of products for certain types of applications are based on Vishay's knowledge of typical requirements that are often placed on Vishay products in generic applications. Such statements are not binding statements about the suitability of products for a particular application. It is the customer's responsibility to validate that a particular product with the properties described in the product specification is suitable for use in a particular application. Parameters provided in datasheets and/or specifications may vary in different applications and performance may vary over time. All operating parameters, including typical parameters, must be validated for each customer application by the customer's technical experts. Product specifications do not expand or otherwise modify Vishay's terms and conditions of purchase, including but not limited to the warranty expressed therein.

Except as expressly indicated in writing, Vishay products are not designed for use in medical, life-saving, or life-sustaining applications or for any other application in which the failure of the Vishay product could result in personal injury or death. Customers using or selling Vishay products not expressly indicated for use in such applications do so at their own risk and agree to fully indemnify and hold Vishay and its distributors harmless from and against any and all claims, liabilities, expenses and damages arising or resulting in connection with such use or sale, including attorneys fees, even if such claim alleges that Vishay or its distributor was negligent regarding the design or manufacture of the part. Please contact authorized Vishay personnel to obtain written terms and conditions regarding products designed for such applications.

No license, express or implied, by estoppel or otherwise, to any intellectual property rights is granted by this document or by any conduct of Vishay. Product names and markings noted herein may be trademarks of their respective owners.

Material Category Policy

Vishay Intertechnology, Inc. hereby certifies that all its products that are identified as RoHS-Compliant fulfill the definitions and restrictions defined under Directive 2011/65/EU of The European Parliament and of the Council of June 8, 2011 on the restriction of the use of certain hazardous substances in electrical and electronic equipment (EEE) - recast, unless otherwise specified as non-compliant.

Please note that some Vishay documentation may still make reference to RoHS Directive 2002/95/EC. We confirm that all the products identified as being compliant to Directive 2002/95/EC conform to Directive 2011/65/EU.