

Available from Midas Components LTD
Telephone Number: +44(0) 1493 602602
Website: www.midascomponents.co.uk
Email: sales@midascomponents.co.uk

Specification for BTHQ 21605V-FSRE-I2C-COG

Version October 2003

OCT/2003

PAGE 2 OF 11

DOCUMENT REVISION HISTORY 1:

DOCUMENT REVISION FROM TO	DATE	DESCRIPTION	CHANGED BY	CHECKED BY
A	2003.10.16	First release.	SUNNY LEE	MICHAEL TSE

CONTENTS

	<u>Page No.</u>
1. GENERAL DESCRIPTION	4
2. MECHANICAL SPECIFICATIONS	4
3. INTERFACE SIGNALS	7
4. ABSOLUTE MAXIMUM RATINGS	7
4.1 ELECTRICAL MAXIMUM RATINGS (Ta=25°C)	7
4.2 ENVIRONMENTAL CONDITION	7
5. ELECTRICAL SPECIFICATIONS	8
5.1 TYPICAL ELECTRICAL CHARACTERISTICS	8
5.2 TIMING SPECIFICATIONS	9
6. CHARACTER SET 'R' IN CGROM	11

**Specification
of
LCD Module Type
Model No.: COG-BTHQ21605-02**

1. General Description

- 16 characters (5 x 8 dots) x 2 lines FSTN Positive Black & White Reflective LCD Character module.
- Driving scheme: 1:18 multiplexed drive, 1/4 bias.
- Optimal view direction: 6 O'clock.
- Driving IC: 'PHILIPS' PCF 2119RU/2/F2 COG form LCD controller/driver.
- Data interface: I²C-bus.
- RTV coating.

2. Mechanical Specifications

The mechanical detail is shown in Fig. 2 and summarized in Table 1 below.

Table 1

Parameter	Specifications	Unit
Outline dimensions	67.00(W) x 27.8(H) x 2.80(D) (Excluded pins and epoxy)	mm
Viewing area	61.0(W) x 15.8(H)	mm
Active area	56.20(W) x 11.50(H)	mm
Display format	16 characters (5 x 8 dots) x 2 lines	-
Character size	2.95(W) x 5.553(H)	mm
Character spacing	0.60(W) x 0.394(H)	mm
Character pitch	3.55(W) x 5.947(H)	mm
Dot size	0.578(W) x 0.681(H)	mm
Dot spacing	0.015(W) x 0.015(H)	mm
Dot pitch	0.593(W) x 0.696(H)	mm
Weight	Approx. 10.0	grams

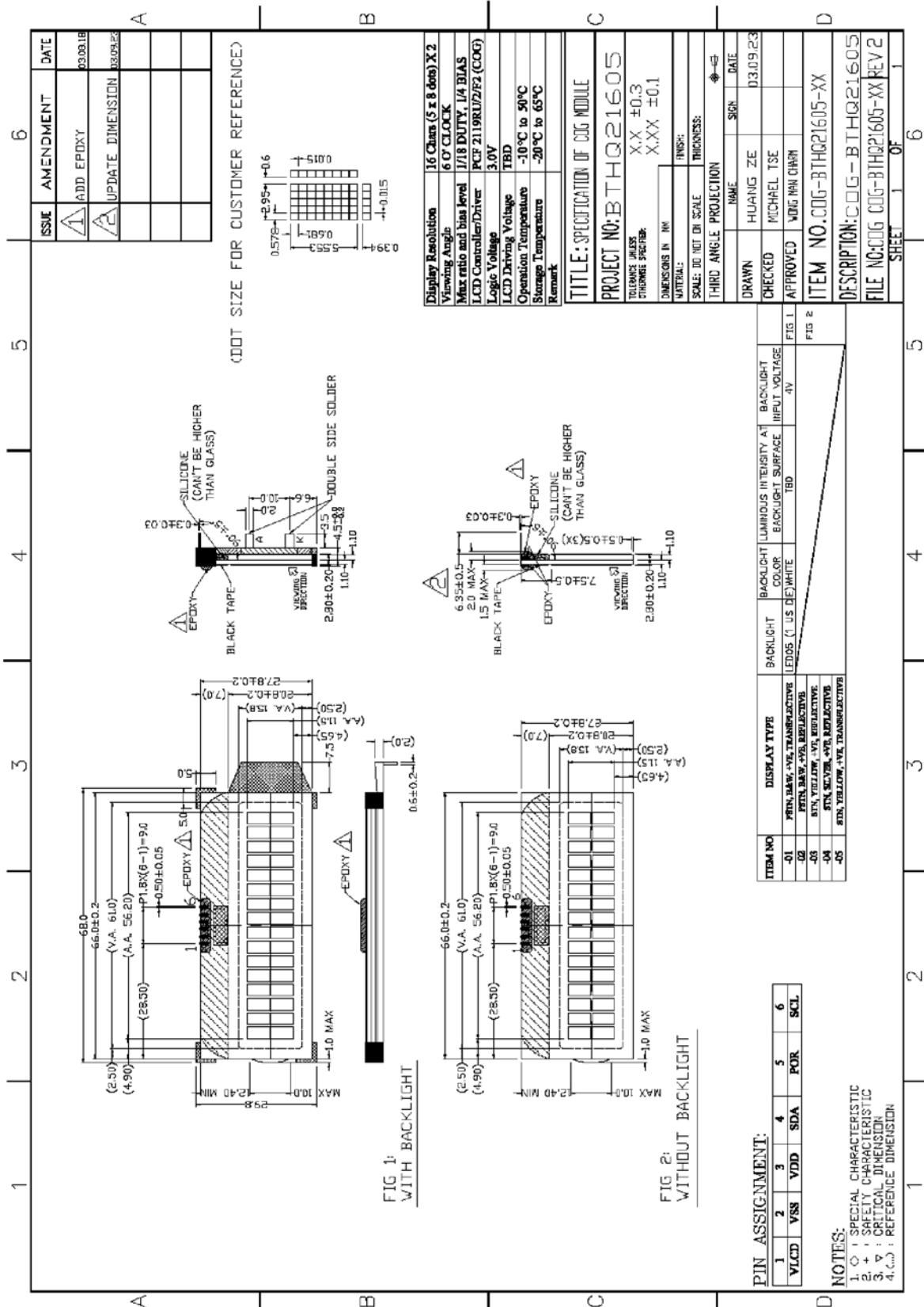

Figure 1 and Figure 2: Specification Drawing

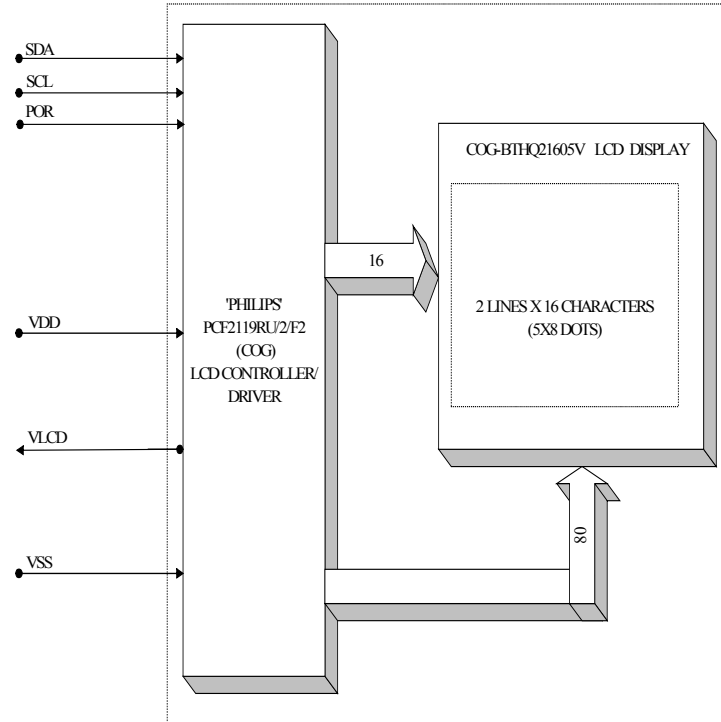
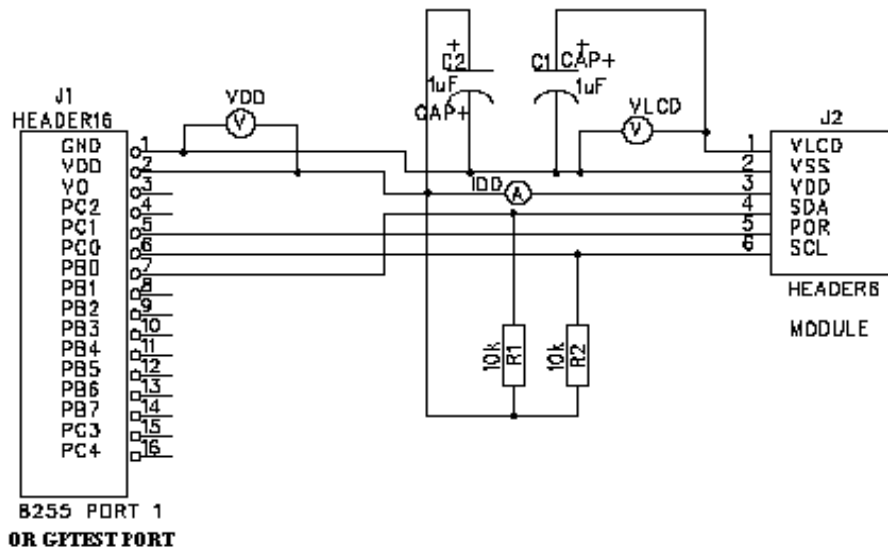

Figure 3: Block Diagram



NOTES

1. VLCD is measured between pin 1 (VLCD) & pin 2 (VSS) of module
2. IDD is measured in series between pin 2 (VDD) of B255 or gpttest and pin 3 (VDD) of module
3. VDD=3V is measured between pin 2 (VDD) & pin 1 (GND) of B255 or gpttest

Figure 4: Reference Circuit

3. Interface signals

Table 2

Pin No.	Symbol	Description
1	VLCD	LCD driver voltage
2	VSS	Ground (0V)
3	VDD	Power supply for logic.
4	SDA	I ² C serial data input/output
5	POR	External power –on reset input. Active High.
6	SCL	I ² C serial clock input

4. Absolute Maximum Ratings

4.1 Electrical Maximum Ratings (Ta = 25 °C)

Table 3

Parameter	Condition	Symbol	Min.	Max.	Unit
Supply voltage range (Logic)	-	VDD - VSS	-0.5	+4.0	V
Input voltage range	OSC,SCL,SDA	Vi	-0.5	VDD +0.5	V
Input voltage range (LCD)		V _{LCD}	-0.5	+6.5	V

Note:

The modules may be destroyed if they are used beyond the absolute maximum ratings.

All voltage values are referenced to VSS = 0V.

4.2 Environmental Condition

Table 4

Item	Operating Temperature (Topr)		Storage Temperature (Tstg)		Remark
	Min.	Max.	Min.	Max.	
Ambient Temperature	-10°C	+50°C	-20°C	+65°C	Dry
Humidity	95% max. RH for Ta ≤ 40°C < 95% RH for Ta > 40°C				no condensation
Vibration (IEC 68-2-6) cells must be mounted on a suitable connector	Frequency: 10 ~ 55 Hz Amplitude: 0.75 mm Duration: 20 cycles in each direction.				3 directions
Shock (IEC 68-2-27) Half-sine pulse shape	Pulse duration : 11 ms Peak acceleration: 981 m/s ² = 100g Number of shocks : 3 shocks in 3 mutually perpendicular axes.				3 directions

5. Electrical Specifications

5.1 Typical Electrical Characteristics

At $T_a = 25\text{ }^\circ\text{C}$, $V_{DD} = 3\text{V}\pm 5\%$, $V_{SS}=0\text{V}$.

Table 5

Parameter	Symbol	Conditions	Min.	Typ.	Max.	Unit
Operating voltage (Logic)	VDD-VSS		2.85	3.0	3.15	V
Operating voltage for LCD (built-in)	VLCD-VSS	Note 1	5.0	5.3	5.6	V
Input signal voltage low (SDA, SCL)	Vil		0	-	0.3 VDD	V
Input signal voltage high (SDA, SCL)	Vih		0.7 VDD	-	5.5	V
Operating supply current	I _{DD}	Character mode, VDD =3.0V	-	0.17	0.26	mA
		Checker board mode, VDD =3.0V	-	0.18	0.27	mA

Note (1) : There is tolerance in optimum LCD driving voltage during production and it will be within the specified range.

5.2 Timing Specifications

Ta = -10 °C to +50 °C, VDD = 1.8 ~ 5.5V, VSS=0V; V_{LCD}= 2.2V to 6.5V.

Refer to Fig. 5, I²C Bus Timing Diagram of 'PHILIPS' PCF2119.

Table 6

Parameters	Symbol	Min.	Typ.	Max.	Unit
LCD frame frequency (internal clock) (note 1)	f _{FR}	45	81	147	Hz
Oscillator frequency(not available at any pin)	f _{OSC}	140	250	450	kHz
External clock frequency	f _{OSC(ext)}	tbf	-	450	kHz
Oscillator start-up time after power-down	t _{OSCST}	-	200	300	μs
Timing characteristics: I²C-bus interface; (note 2)					
SCL clock frequency	f _{SCL}	-	-	400	kHz
SCL clock LOW period	t _{LOW}	1.3	-	-	μs
SCL clock HIGH period	t _{HIGH}	0.6	-	-	μs
Data set-up time	t _{SU;DAT}	100	-	-	ns
Data hold time	t _{HD;DAT}	0	-	-	ns
SCL and SDA rise time	t _r	-	-	300	ns
SCL and SDA fall time	t _f	-	-	300	ns
Capacitive bus line load	C _B			400	pF
Set-up time for a repeated START condition	t _{SU;STA}	0.6	-	-	μs
START condition hold time	t _{HD;STA}	0.6	-	-	μs
Set-up time for STOP condition	t _{SU;STO}	0.6	-	-	μs
Tolerable spike width on bus	t _{SW}	-	-	50	ns

Notes :

1. VDD=5.0V.

2. All timing values are valid within the operating supply voltage and ambient temperature range and are referenced to V_{IL} and V_{IH} with an input voltage swing to VSS to VDD.

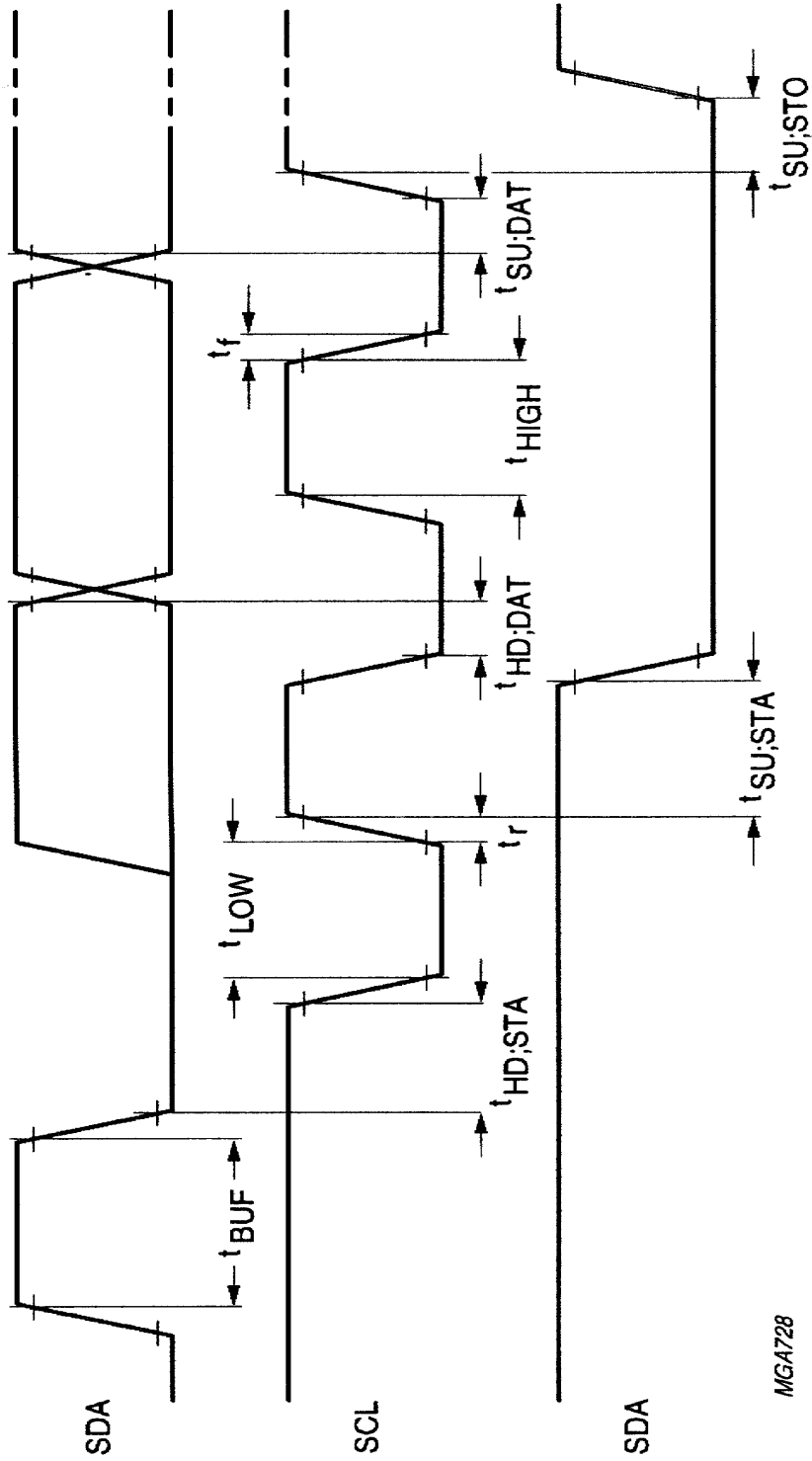

Figure 5: I²C Bus Timing Diagram of 'PHILIPS' PCF2119.

