

Description

The 74LVC2G04 is a dual inverter gate with standard push-pull outputs. The device is designed for operation with a power supply range of 1.65V to 5.5V. The inputs are tolerant to 5.5V allowing this device to be used in a mixed voltage environment. The device is fully specified for partial power down applications using I_{OFF}. The I_{OFF} circuitry disables the output preventing damaging current backflow when the device is powered down.

The gate performs the positive Boolean function:

$$Y = \overline{A}$$

Features

- Wide Supply Voltage Range from 1.65V to 5.5V
- ±24mA Output Drive at 3.0V
- CMOS low power consumption
- IOFF Supports Partial-Power-Down Mode Operation
- Inputs accept up to 5.5V
- ESD Protection Tested per JESD 22
 - Exceeds 200-V Machine Model (A115)
 - Exceeds 2000-V Human Body Model (A114)
 - Exceeds 1000-V Charged Device Model (C101)
- Latch-Up Exceeds 100mA per JESD 78, Class I
- DFN1409 package designed as a direct replacement for chip scale packaging.
- Range of Package Options SOT26, SOT353, DFN1010, DFN1409 and DFN1410
- Leadless packages per JESD30E
 - DFN1410 denoted as X2-DFN1410-6
 - DFN1409 denoted as X2-DFN1409-6
 - DFN1010 denoted as X2-DFN1010-6
- **Totally Lead-Free & Fully RoHS Compliant (Notes 1 & 2)**
- **Halogen and Antimony Free. "Green" Device (Note 3)**

- Notes:
1. No purposely added lead. Fully EU Directive 2002/95/EC (RoHS) & 2011/65/EU (RoHS 2) compliant.
 2. See http://www.diodes.com/quality/lead_free.html for more information about Diodes Incorporated's definitions of Halogen- and Antimony-free, "Green" and Lead-free.
 3. Halogen- and Antimony-free "Green" products are defined as those which contain <900ppm bromine, <900ppm chlorine (<1500ppm total Br + Cl) and <1000ppm antimony compounds.

Pin Assignment

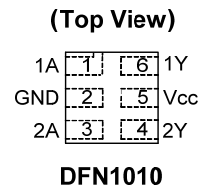
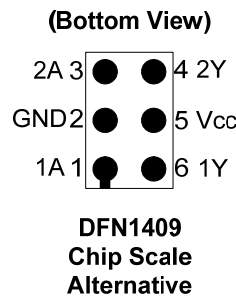
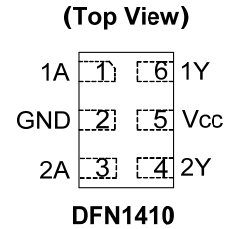
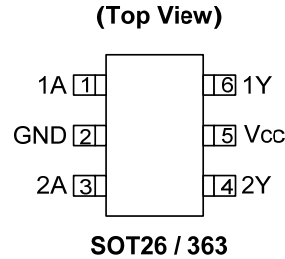

Applications

- Voltage Level Shifting
- General Purpose Logic
- Power Down Signal Isolation
- Wide array of products such as:
 - PCs, networking, notebooks, netbooks, tablets
 - Computer peripherals, hard drives, CD/DVD ROM
 - TV, DVD, DVR, set top box
 - Cell Phones, Personal Navigation / GPS
 - MP3 players, Cameras, Video Recorders

[Click here for ordering information, located at the end of datasheet](#)

Pin Descriptions

Pin Name	Pin NO	Function
1A	1	Data Input
GND	2	Ground
2A	3	Data Input
2Y	4	Data Output
V _{CC}	5	Supply Voltage
1Y	6	Data Output

Logic Diagram

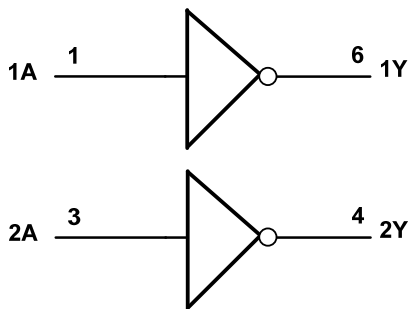

Function Table

Inputs	Output
A	Y
H	L
L	H

Absolute Maximum Ratings (Note 4) (@T_A = +25°C, unless otherwise specified.)

Symbol	Description	Rating	Unit
ESD HBM	Human Body Model ESD Protection	2	kV
ESD CDM	Charged Device Model ESD Protection	1	kV
ESD MM	Machine Model ESD Protection	200	V
V _{CC}	Supply Voltage Range	-0.5 to +6.5	V
V _I	Input Voltage Range	-0.5 to +6.5	V
V _O	Voltage applied to output in high impedance or I _{OFF} state	-0.5 to +6.5	V
V _O	Voltage applied to output in high or low state	-0.3 to V _{CC} +0.5	V
I _{IK}	Input Clamp Current V _I < 0	-50	mA
I _{OK}	Output Clamp Current V _O < 0	-50	mA
I _O	Continuous Output Current	-50	mA
	Continuous Current Through V _{DD} or GND	±100	mA
T _J	Operating Junction Temperature	-40 to +150	°C
T _{STG}	Storage Temperature	-65 to +150	°C

Note: 4. Stresses beyond the absolute maximum may result in immediate failure or reduced reliability. These are stress values and device operation should be within recommend values.

Recommended Operating Conditions (Note 5) (@ $T_A = +25^\circ\text{C}$, unless otherwise specified.)

Symbol	Parameter	Min	Max	Unit	
V_{CC}	Operating Voltage	Operating	1.65	5.5	V
		Data retention only	1.5		V
V_{IH}	High-Level Input Voltage	$V_{CC} = 1.65\text{V to }1.95\text{V}$	$0.65 \times V_{CC}$		V
		$V_{CC} = 2.3\text{V to }2.7\text{V}$	1.7		
		$V_{CC} = 3\text{V to }3.6\text{V}$	2		
		$V_{CC} = 4.5\text{V to }5.5\text{V}$	$0.7 \times V_{CC}$		
V_{IL}	Low-Level Input Voltage	$V_{CC} = 1.65\text{V to }1.95\text{V}$		$0.35 \times V_{CC}$	V
		$V_{CC} = 2.3\text{V to }2.7\text{V}$		0.7	
		$V_{CC} = 3\text{V to }3.6\text{V}$		0.8	
		$V_{CC} = 4.5\text{V to }5.5\text{V}$		$0.3 \times V_{CC}$	
V_I	Input Voltage	0	5.5	V	
V_O	Output Voltage	0	V_{CC}	V	
I_{OH}	High-Level Output Current	$V_{CC} = 1.65\text{V}$		-4	mA
		$V_{CC} = 2.3\text{V}$		-8	
		$V_{CC} = 3\text{V}$		-16	
				-24	
$V_{CC} = 4.5\text{V}$		-32			
I_{OL}	Low-Level Output Current	$V_{CC} = 1.65\text{V}$		4	mA
		$V_{CC} = 2.3\text{V}$		8	
		$V_{CC} = 3\text{V}$		16	
				24	
$V_{CC} = 4.5\text{V}$		32			
$\Delta t/\Delta V$	Input Transition Rise or Fall Rate	$V_{CC} = 1.8\text{V} \pm 0.15\text{V}, 2.5\text{V} \pm 0.2\text{V}$		20	ns/V
		$V_{CC} = 3.3\text{V} \pm 0.3\text{V}$		10	
		$V_{CC} = 5\text{V} \pm 0.5\text{V}$		5	
T_A	Operating free-air temperature	-40	125	$^\circ\text{C}$	

Note: 5. Unused inputs should be held at V_{CC} or Ground.

Electrical Characteristics

Symbol	Parameter	Test Conditions	V _{CC}	-40°C to +85°C		-40°C to +125°C		Unit
				Min	Max	Min	Max	
V _{OH}	High-Level Output Voltage	I _{OH} = -100μA	1.65V to 5.5V	V _{CC} - 0.1		V _{CC} - 0.1		V
		I _{OH} = -4mA	1.65V	1.2		0.95		
		I _{OH} = -8mA	2.3V	1.9		1.7		
		I _{OH} = -16mA	3V	2.4		1.9		
		I _{OH} = -24mA		2.3		2.0		
		I _{OH} = -32mA	4.5V	3.8		3.4		
V _{OL}	Low-Level Output Voltage	I _{OL} = 100μA	1.65V to 5.5V		0.1		0.1	V
		I _{OL} = 4mA	1.65V		0.45		0.70	
		I _{OL} = 8mA	2.3V		0.3		0.45	
		I _{OL} = 16mA	3V		0.4		0.60	
		I _{OL} = 24mA			0.55		0.80	
		I _{OL} = 32mA	4.5V		0.55		0.80	
I _I	Input Current	V _I = 5.5V or GND	0 to 5.5V		± 5		± 20	μA
I _{OFF}	Power Down Leakage Current	V _I or V _O = 5.5V	0		± 10		± 20	μA
I _{CC}	Supply Current	V _I = 5.5V or GND I _O = 0	1.65V to 5.5V		10		40	μA
ΔI _{CC}	Additional Supply Current	Input at V _{CC} -0.6V	3V to 5.5V		500		5000	μA

Package Characteristics (All typical values are at V_{CC} = 3.3V, T_A = 25°C.)

Symbol	Parameter	Package	Conditions	Min	Typ	Max	Unit
C _I	Input Capacitance	Typical of all packages	V _{CC} = 3.3V V _I = V _{CC} - or GND		3.5		pF
θ _{JA}	Thermal Resistance Junction-to-Ambient	SOT26	(Note 6)		204		°C/W
		SOT363			371		
		X2-DFN1410-6			430		
		X2-DFN1409-6			450		
		X2-DFN1010-6			510		
θ _{JC}	Thermal Resistance Junction-to-Case	SOT26	(Note 6)		52		°C/W
		SOT363			143		
		X2-DFN1410-6			190		
		X2-DFN1409-6			225		
		X2-DFN1010-6			250		

Note: 6. Test condition for SOT26, SOT363, X2-DFN1410-6, X2-DFN1409-6 and X2-DFN1010 -6: Device mounted on FR-4 substrate PC board, 2oz copper with minimum recommended pad layout.

Switching Characteristics

$T_A = -40^\circ\text{C}$ to $+85^\circ\text{C}$, $C_L = 30$ or 50pF (see Figure 1)

Parameter	From (Input)	TO (OUTPUT)	$V_{CC} = 1.8\text{V} \pm 0.15\text{V}$		$V_{CC} = 2.5\text{V} \pm 0.2\text{V}$		$V_{CC} = 3.3\text{V} \pm 0.3\text{V}$		$V_{CC} = 5\text{V} \pm 0.5\text{V}$		Unit
			Min	Max	Min	Max	Min	Max	Min	Max	
t_{pd}	A	Y	0.5	8.0	1.0	4.4	0.5	4.1	0.5	3.2	ns

$T_A = -40^\circ\text{C}$ to $+125^\circ\text{C}$, $C_L = 30$ or 50pF (see Figure 1)

Parameter	From (Input)	TO (OUTPUT)	$V_{CC} = 1.8\text{V} \pm 0.15\text{V}$		$V_{CC} = 2.5\text{V} \pm 0.2\text{V}$		$V_{CC} = 3.3\text{V} \pm 0.3\text{V}$		$V_{CC} = 5\text{V} \pm 0.5\text{V}$		Unit
			Min	Max	Min	Max	Min	Max	Min	Max	
t_{pd}	A	Y	0.5	9.5	0.5	5.4	0.5	5.5	0.5	3.8	ns

Operating Characteristics

$T_A = +25^\circ\text{C}$

Parameter		Test Conditions	$V_{CC} = 1.8\text{V}$	$V_{CC} = 2.5\text{V}$	$V_{CC} = 3.3\text{V}$	$V_{CC} = 5\text{V}$	Unit
			Typ	Typ	Typ	Typ	
C_{pd}	Power dissipation capacitance	$f = 10\text{MHz}$	17	19	20	21	pF

Parameter Measurement Information

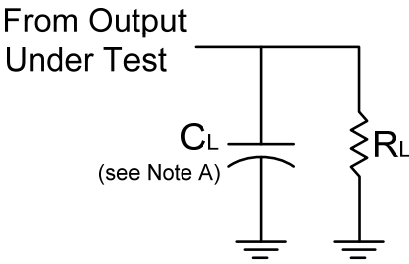

V_{CC}	Inputs		V_M	C_L	R_L
	V_I	t_r/t_f			
1.8V±0.15V	V_{CC}	≤2ns	$V_{CC}/2$	30 pF	1 kΩ
2.5V±0.2V	V_{CC}	≤2ns	$V_{CC}/2$	30 pF	500 Ω
3.3V±0.3V	3V	≤2.5ns	1.5 V	50 pF	500 Ω
5V±0.5V	V_{CC}	≤2.5ns	$V_{CC}/2$	50 pF	500 Ω

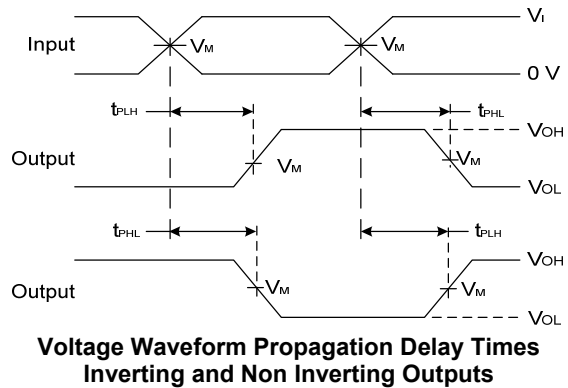
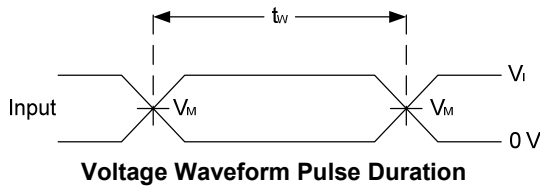
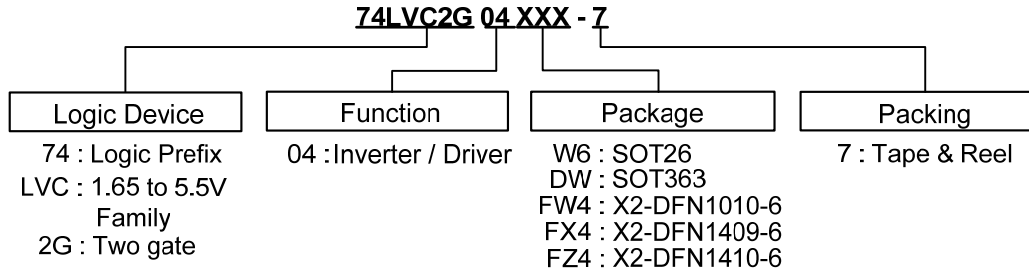

Figure 1. Load Circuit and Voltage Waveforms

- Notes:
- A. Includes test lead and test apparatus capacitance.
 - B. All pulses are supplied at pulse repetition rate ≤ 10 MHz.
 - C. Inputs are measured separately one transition per measurement.
 - D. t_{PLH} and t_{PHL} are the same as t_{PD} .

Ordering Information



Device	Package Code	Packaging (Note 7)	7" Tape and Reel	
			Quantity	Part Number Suffix
74LVC2G04W6-7	W6	SOT26	3000/Tape & Reel	-7
74LVC2G04DW-7	DW	SOT363	3000/Tape & Reel	-7
74LVC2G04FW4-7	FW4	X2-DFN1010-6	5000/Tape & Reel	-7
74LVC2G04FX4-7	FX4	X2-DFN1409-6	5000/Tape & Reel	-7
74LVC2G04FZ4-7	FZ4	X2-DFN1410-6	5000/Tape & Reel	-7

Note: 7. The taping orientation is located on our website at <http://www.diodes.com/datasheets/ap02007.pdf>

Marking Information

(1) SOT26, SOT363

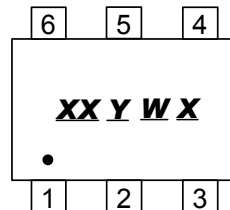

XX : Identification code
Y : Year 0~9
W : Week : A~Z : 1~26 week;
 a~z : 27~52 week; z represents
 52 and 53 week
X : A~Z : Internal Code

Part Number	Package	Identification Code
74LVC2G04W6	SOT26	Z2
74LVC2G04DW	SOT363	Z2

(2) X2-DFN1010-6, X2-DFN1409-6, X2-DFN1410-6

(Top View)

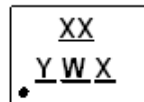

XX : Identification Code
Y : Year : 0~9
W : Week : A~Z : 1~26 week;
 a~z : 27~52 week; z represents
 52 and 53 week
X : A~Z : Internal code

Part Number	Package	Identification Code
74LVC2G04FW4	X2-DFN1010-6	Z2
74LVC2G04FX4	X2-DFN1409-6	X2
74LVC2G04FZ4	X2-DFN1410-6	Z2

Package Outline Dimensions (All dimensions in mm.)

Please see AP02002 at <http://www.diodes.com/datasheets/ap02002.pdf> for latest version.

(1) Package Type: SOT26

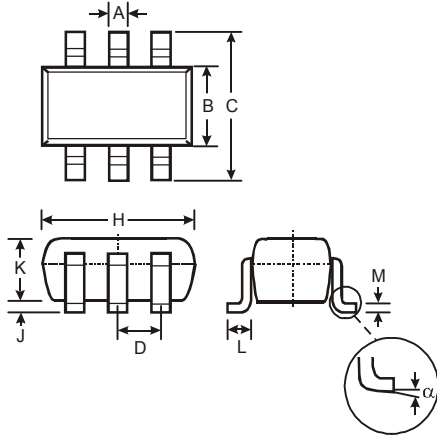

SOT26			
Dim	Min	Max	Typ
A	0.35	0.50	0.38
B	1.50	1.70	1.60
C	2.70	3.00	2.80
D	—	—	0.95
H	2.90	3.10	3.00
J	0.013	0.10	0.05
K	1.00	1.30	1.10
L	0.35	0.55	0.40
M	0.10	0.20	0.15
α	0°	8°	—
All Dimensions in mm			

(2) Package Type: SOT363

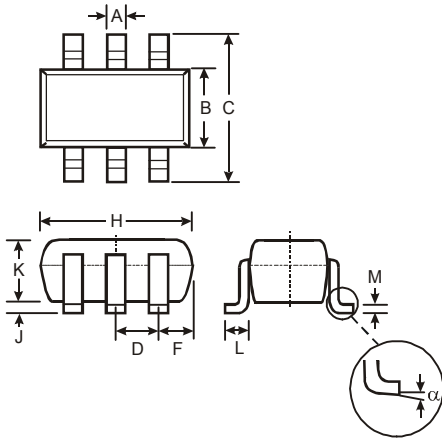

SOT363			
Dim	Min	Max	Typ
A	0.10	0.30	0.25
B	1.15	1.35	1.30
C	2.00	2.20	2.10
D	0.65 Typ		
F	0.40	0.45	0.425
H	1.80	2.20	2.15
J	0	0.10	0.05
K	0.90	1.00	1.00
L	0.25	0.40	0.30
M	0.10	0.22	0.11
α	0°	8°	-
All Dimensions in mm			

(3) Package Type: X2-DFN1010-6

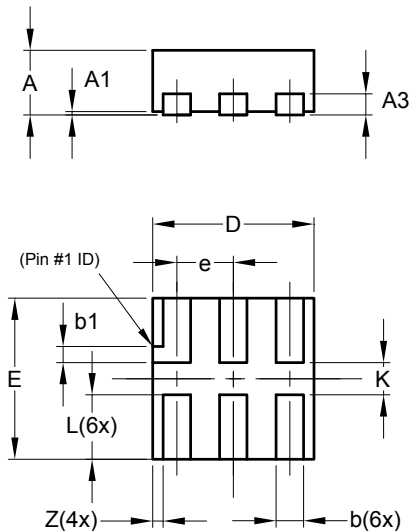

X2-DFN1010-6			
Dim	Min	Max	Typ
A	—	0.40	0.39
A1	0.00	0.05	0.02
A3	—	—	0.13
b	0.14	0.20	0.17
b1	0.05	0.15	0.10
D	0.95	1.05	1.00
E	0.95	1.05	1.00
e	—	—	0.35
L	0.35	0.45	0.40
K	0.15	—	—
Z	—	—	0.065
All Dimensions in mm			

Package Outline Dimensions (cont.) (All dimensions in mm.)

Please see AP02002 at <http://www.diodes.com/datasheets/ap02002.pdf> for latest version.

(4) Package Type X2-DFN1410-6

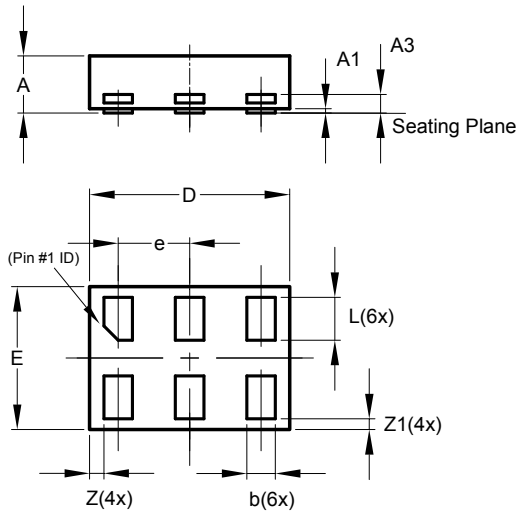

X2-DFN1410-6			
Dim	Min	Max	Typ
A	—	0.40	0.39
A1	0.00	0.05	0.02
A3	—	—	0.13
b	0.15	0.25	0.20
D	1.35	1.45	1.40
E	0.95	1.05	1.00
e	—	—	0.50
L	0.25	0.35	0.30
Z	—	—	0.10
Z1	0.045	0.105	0.075
All Dimensions in mm			

(5) Package Type: X2-DFN1409-6 Chip Scale Replacement

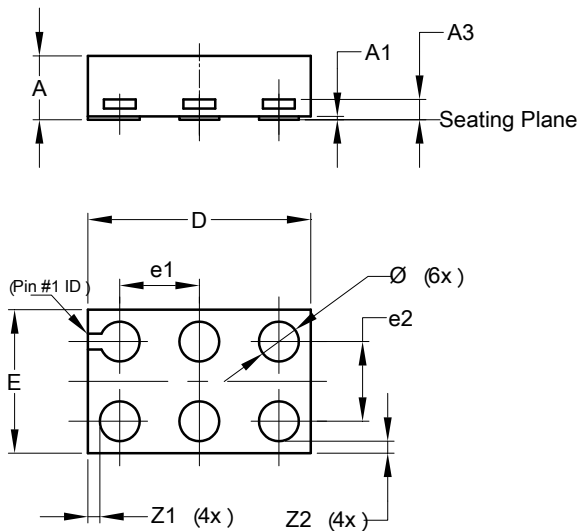

X2-DFN1409-6			
Dim	Min	Max	Typ
A	—	0.40	0.39
A1	0	0.05	0.02
A3	—	—	0.13
∅	0.20	0.30	0.25
D	1.35	1.45	1.40
E	0.85	0.95	0.90
e1	—	—	0.50
e2	—	—	0.50
Z1	—	—	0.075
Z2	—	—	0.075
All Dimensions in mm			

Suggested Pad Layout

Please see AP02001 at <http://www.diodes.com/datasheets/ap02001.pdf> for the latest version.

(1) Package Type: SOT26

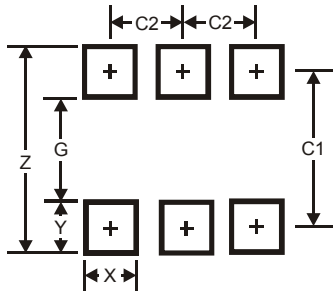

Dimensions	Value (in mm)
Z	3.20
G	1.60
X	0.55
Y	0.80
C1	2.40
C2	0.95

(2) Package Type: SOT363

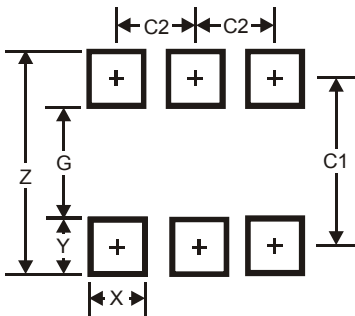

Dimensions	Value (in mm)
Z	2.5
G	1.3
X	0.42
Y	0.6
C1	1.9
C2	0.65

(3) Package Type: X2-DFN1010-6

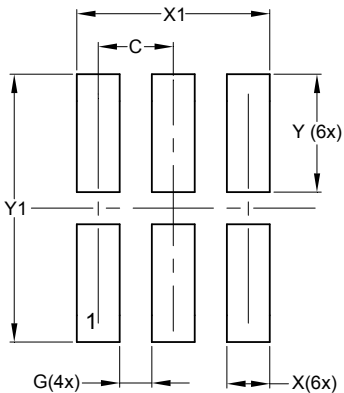

Dimensions	Value (in mm)
C	0.350
G	0.150
X	0.200
X1	0.900
Y	0.550
Y1	1.250

Suggested Pad Layout (cont.)

Please see AP02001 at <http://www.diodes.com/datasheets/ap02001.pdf> for the latest version.

(4) Package Type X2-DFN1410-6

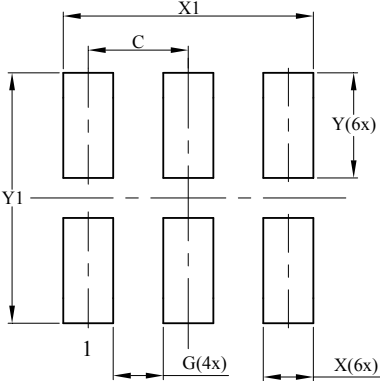

Dimensions	Value (in mm)
C	0.500
G	0.250
X	0.250
X1	1.250
Y	0.525
Y1	1.250

(5) Package Type: X2-DFN1409-6 Chip Scale Replacement

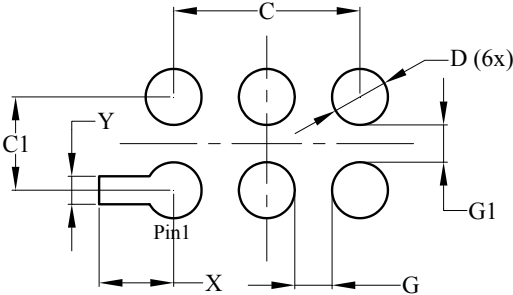

Dimensions	Value (in mm)
C	1.000
C1	0.500
D	0.300
G	0.200
G1	0.200
X	0.400
Y	0.150

IMPORTANT NOTICE

DIODES INCORPORATED MAKES NO WARRANTY OF ANY KIND, EXPRESS OR IMPLIED, WITH REGARDS TO THIS DOCUMENT, INCLUDING, BUT NOT LIMITED TO, THE IMPLIED WARRANTIES OF MERCHANTABILITY AND FITNESS FOR A PARTICULAR PURPOSE (AND THEIR EQUIVALENTS UNDER THE LAWS OF ANY JURISDICTION).

Diodes Incorporated and its subsidiaries reserve the right to make modifications, enhancements, improvements, corrections or other changes without further notice to this document and any product described herein. Diodes Incorporated does not assume any liability arising out of the application or use of this document or any product described herein; neither does Diodes Incorporated convey any license under its patent or trademark rights, nor the rights of others. Any Customer or user of this document or products described herein in such applications shall assume all risks of such use and will agree to hold Diodes Incorporated and all the companies whose products are represented on Diodes Incorporated website, harmless against all damages.

Diodes Incorporated does not warrant or accept any liability whatsoever in respect of any products purchased through unauthorized sales channel.

Should Customers purchase or use Diodes Incorporated products for any unintended or unauthorized application, Customers shall indemnify and hold Diodes Incorporated and its representatives harmless against all claims, damages, expenses, and attorney fees arising out of, directly or indirectly, any claim of personal injury or death associated with such unintended or unauthorized application.

Products described herein may be covered by one or more United States, international or foreign patents pending. Product names and markings noted herein may also be covered by one or more United States, international or foreign trademarks.

This document is written in English but may be translated into multiple languages for reference. Only the English version of this document is the final and determinative format released by Diodes Incorporated.

LIFE SUPPORT

Diodes Incorporated products are specifically not authorized for use as critical components in life support devices or systems without the express written approval of the Chief Executive Officer of Diodes Incorporated. As used herein:

A. Life support devices or systems are devices or systems which:

1. are intended to implant into the body, or
2. support or sustain life and whose failure to perform when properly used in accordance with instructions for use provided in the labeling can be reasonably expected to result in significant injury to the user.

B. A critical component is any component in a life support device or system whose failure to perform can be reasonably expected to cause the failure of the life support device or to affect its safety or effectiveness.

Customers represent that they have all necessary expertise in the safety and regulatory ramifications of their life support devices or systems, and acknowledge and agree that they are solely responsible for all legal, regulatory and safety-related requirements concerning their products and any use of Diodes Incorporated products in such safety-critical, life support devices or systems, notwithstanding any devices- or systems-related information or support that may be provided by Diodes Incorporated. Further, Customers must fully indemnify Diodes Incorporated and its representatives against any damages arising out of the use of Diodes Incorporated products in such safety-critical, life support devices or systems.

Copyright © 2013, Diodes Incorporated

www.diodes.com