

Lightning arrester type 1 - FLT 35 CTRL-0.9/I/50 - 2800174

Please be informed that the data shown in this PDF Document is generated from our Online Catalog. Please find the complete data in the user's documentation. Our General Terms of Use for Downloads are valid (<http://phoenixcontact.com/download>)



Type 1/Class I/B arrester (lightning arrester) with encapsulated arc chopping spark gap and ignition electronics with control lamp, single-channel. Housing width: 17.5 mm (1 div.)



Key commercial data

Packing unit	1
GTIN	 4 046356 498807
Custom tariff number	85363030

Technical data

Ambient conditions

Degree of protection	IP20
----------------------	------

General

Inflammability class according to UL 94	V0
Color	black
Type	Rail-mountable module, one-piece
Surge protection fault message	Optical
Direction of action	1L-N/PE

Protective circuit

IEC test classification	I
	T1
EN type	T1
Nominal voltage U_N	230 V AC
Maximum continuous operating voltage U_C	260 V AC
Maximum continuous operating voltage U_C (L-N)	260 V AC
Maximum continuous operating voltage U_C (L-PEN)	260 V AC
Nominal frequency f_N	50 Hz
	60 Hz

Lightning arrester type 1 - FLT 35 CTRL-0.9/I/50 - 2800174

Technical data

Protective circuit

Residual current I_{PE}	≤ 2.5 mA
Operating effective current I_C at U_N	≤ 2.5 mA
Nominal discharge current I_n (8/20) μ s	35 kA
Nominal discharge current I_n (8/20) μ s (L-N)	35 kA
Nominal discharge current I_n (8/20) μ s (L-PEN)	35 kA
Impulse discharge current (10/350) μ s charge	17.5 As
Impulse discharge current (10/350) μ s, specific energy	305 kJ/ Ω
Impulse discharge current (10/350) μ s, peak value I_{imp}	35 kA
100% lightning impulse sparkover voltage (1.2/50) μ s	≤ 0.9 kV
Voltage protection level U_p	≤ 0.9 kV
Voltage protection level U_p (L-N)	≤ 0.9 kV
Voltage protection level U_p (L-PEN)	≤ 0.9 kV
Response time	≤ 100 ns
Response time (L-N)	≤ 100 ns
Response time (L-PEN)	≤ 100 ns
Max. backup fuse with branch wiring	125 A (gL)
Short-circuit resistance I_P with max. backup fuse (effective)	25 kA
Short-circuit current self-quenching	3 kA (260 V)
Follow current quenching capacity I_f (L-N)	3 kA
Follow current quenching capacity I_f (L-PEN)	3 kA

Connection, protective circuit

Connection method	Screw connection
Connection type IN	Biconnect screw terminal block
Connection type OUT	Biconnect screw terminal block
Connection method	Biconnect terminal block
Screw thread	M5
Tightening torque	4.5 Nm
Stripping length	14.5 mm
Conductor cross section stranded min.	0.5 mm ²
Conductor cross section stranded max.	25 mm ²
Conductor cross section solid min.	0.5 mm ²
Conductor cross section solid max.	35 mm ²
Conductor cross section AWG/kcmil min.	20
Conductor cross section AWG/kcmil max	2

Classifications

eCl@ss

eCl@ss 4.0	27140201
eCl@ss 4.1	27140201

Lightning arrester type 1 - FLT 35 CTRL-0.9/I/50 - 2800174

Classifications

eCl@ss

eCl@ss 5.0	27130801
eCl@ss 5.1	27130801
eCl@ss 6.0	27130802
eCl@ss 7.0	27130802
eCl@ss 8.0	27130802

ETIM

ETIM 2.0	EC000381
ETIM 3.0	EC000381
ETIM 4.0	EC000381
ETIM 5.0	EC000381

UNSPSC

UNSPSC 6.01	30212010
UNSPSC 7.0901	39121610
UNSPSC 11	39121610
UNSPSC 12.01	39121610
UNSPSC 13.2	39121620

Approvals

Approvals

Approvals

EAC

Ex Approvals

Approvals submitted

Approval details

EAC

Accessories

Accessories

Device marking

Lightning arrester type 1 - FLT 35 CTRL-0.9/I/50 - 2800174

Accessories

Zack marker strip - ZBN 18:UNBEDRUCKT - 2809128



Zack marker strip, Strip, white, unlabeled, can be labeled with: Plotter, Mounting type: Snap into tall marker groove, for terminal block width: 18 mm, Lettering field: 18 x 5 mm

End block

End clamp - CLIPFIX 35 - 3022218



Quick mounting end clamp for NS 35/7,5 DIN rail or NS 35/15 DIN rail, with marking option, width: 9.5 mm, color: gray

Labeled device marker

Marker for terminal blocks - ZBN 18,LGS:ERDE - 2749589



Marker for terminal blocks, Strip, white, labeled, Horizontal: Grounding symbol, Mounting type: Snap into tall marker groove, for terminal block width: 18 mm, Lettering field: 18 x 5 mm

Marker for terminal blocks - ZBN 18,LGS:L1-N,ERDE - 2749576



Marker for terminal blocks, Strip, white, labeled, Horizontal: L1, L2, L3, N, GND, Mounting type: Snap into tall marker groove, for terminal block width: 18 mm, Lettering field: 18 x 5 mm

Marker pen

Marker pen - B-STIFT - 1051993



Marker pen, for manual labeling of unprinted Zack strips, smear-proof and waterproof, line thickness 0.5 mm

Drawings

Lightning arrester type 1 - FLT 35 CTRL-0.9/I/50 - 2800174

Dimensioned drawing

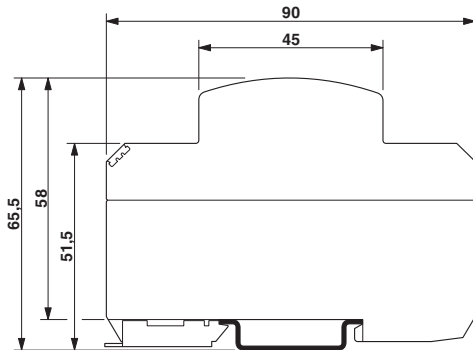

Circuit diagram

