



KIT COMPRISES:
HEATSHRINK BOOT
MAGNAFORM ADAPTOR 70MMTB-U-**-**-1-
(SUPPLIED WITH LOCKING HARDWARE)



27,00

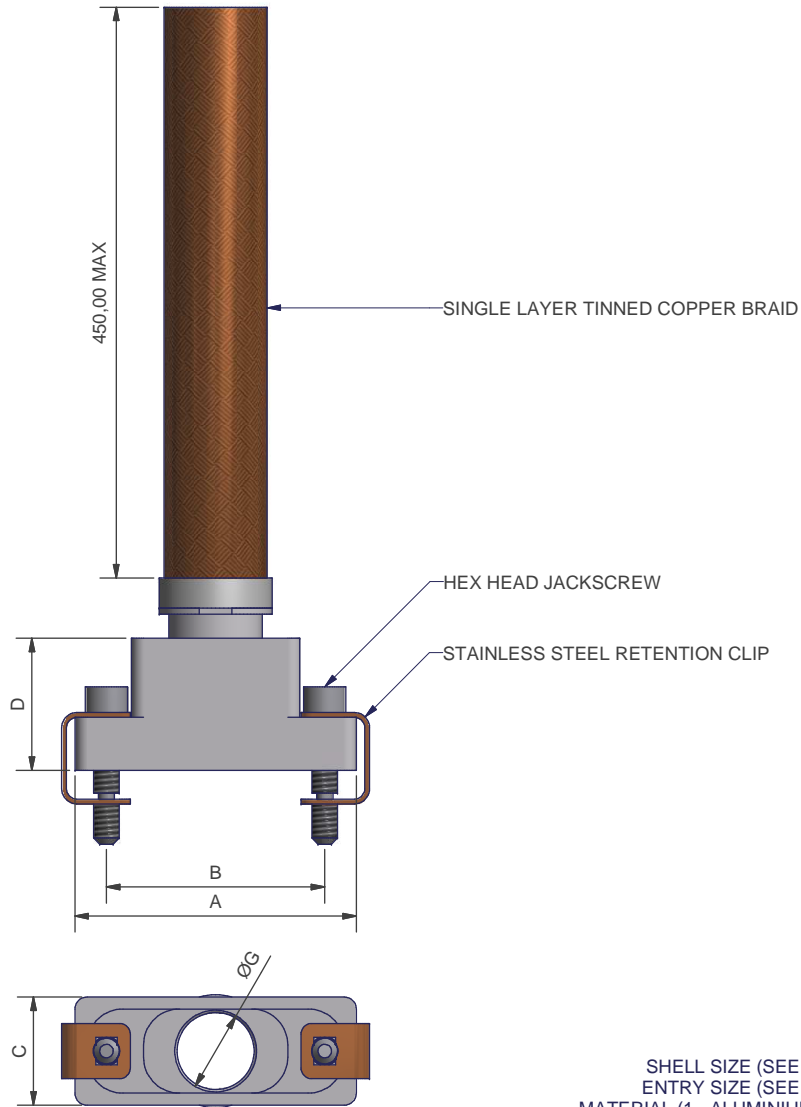

TABLE 1

SHELL SIZE	A	B	C	D
09	19,70	14,35	9,0	11,0
15	23,40	18,16	9,0	11,0
21	27,30	21,97	9,0	11,0
25	29,85	24,51	9,0	15,0
31	33,70	28,32	9,0	15,0
37	37,50	32,13	9,0	20,0
51	36,10	30,86	10,0	20,0

TABLE 2

ENTRY SIZE	G MAX
04	3,2
05	4,0
06	4,8
07	5,6
08	6,4

TABLE 3

CODE	PLATING
C	ELECTROLESS NICKEL AMS-C-26074 CLASS 4 GRADE B
M	BRIGHT CADMIUM OVER NICKEL QQ-P-416 TYPE II CLASS 3
Y	YELLOW CHROMATE OVER CADMIUM QQ-P-416 TYPE II CLASS 2

100P2554-15-08-1-C

SERIES _____
SHELL SIZE (SEE TABLE 1) _____
ENTRY SIZE (SEE TABLE 2) _____
MATERIAL (1 - ALUMINIUM ALLOY) _____
PLATING (TABLE 3) _____

ISSUE	DCR NO.	DATE	APPROVED
1		15/01/2009	NW
2	5635	09/12/2013	

MATERIAL

UNLESS OTHERWISE SPECIFIED
ALL DIMENSIONS IN MILLIMETRES
TOLERANCE ON DIMENSIONS +/-0.1MM
TOLERANCE ON ANGLES +/- 1 DEGREE

WEIGHT _____
DRAWN K.SHEPPARD

DO NOT SCALE THIS DRAWING

THIS DRAWING IS COPYRIGHT, AND THE PROPERTY OF POLAMCO LTD. IT MUST NOT BE COPIED, USED FOR MANUFACTURE OR OTHERWISE DISCLOSED WITHOUT PRIOR WRITTEN CONSENT OF THE COMPANY.

POLAMCO LTD

WESTON LOCK
LOWER BRISTOL ROAD
BATH BA2 1EP

TITLE
MICRO MIN MAGNAFORM ADAPTOR ASSEMBLY AND HEATSHRINK BOOT KIT

PART NO 100P2554-**-**-1-*

ASSY USED ON
MIL-C-83513

DRAWING NO
P9122

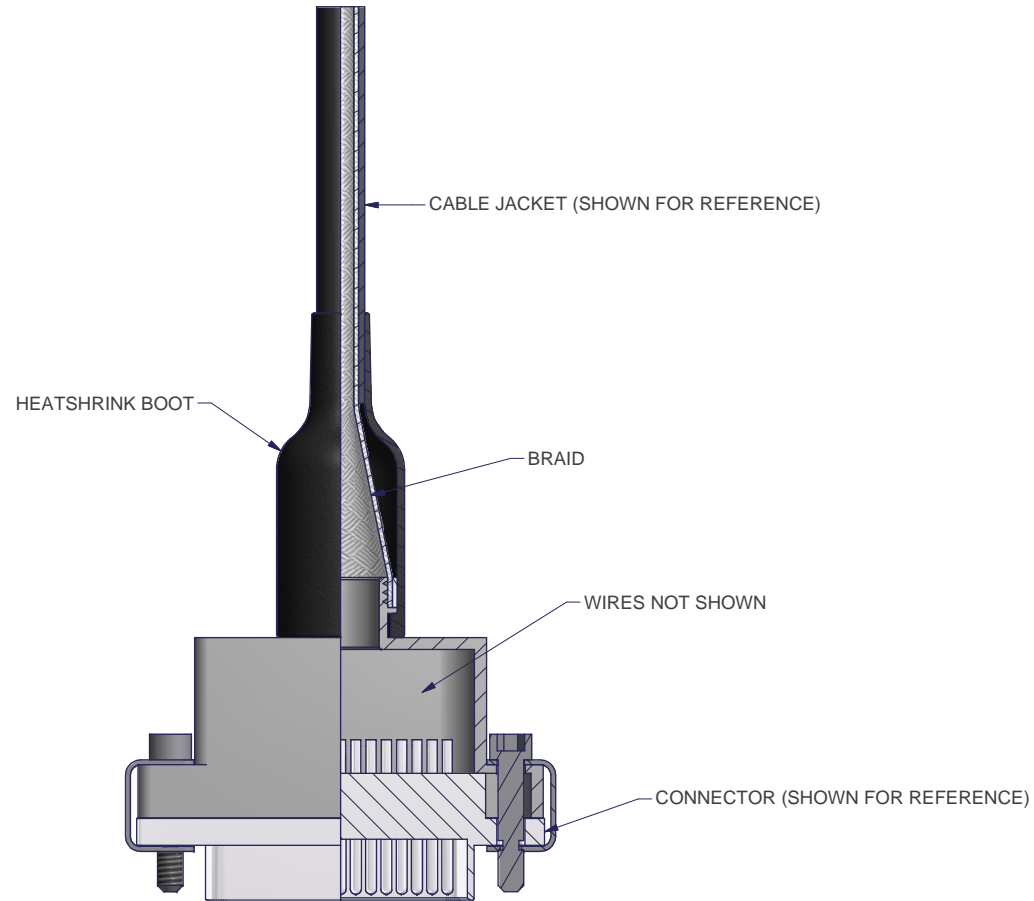

KIT ASSEMBLED WITH CONNECTOR

ISSUE	DCR NO.	DATE	APPROVED	MATERIAL	UNLESS OTHERWISE SPECIFIED ALL DIMENSIONS IN MILLIMETRES TOLERANCE ON DIMENSIONS +/-0.1MM TOLERANCE ON ANGLES +/- 1 DEGREE	DO NOT SCALE THIS DRAWING THIS DRAWING IS COPYRIGHT, AND THE PROPERTY OF POLAMCO LTD. IT MUST NOT BE COPIED, USED FOR MANUFACTURE OR OTHERWISE DISCLOSED WITHOUT PRIOR WRITTEN CONSENT OF THE COMPANY.	POLAMCO LTD WESTON LOCK LOWER BRISTOL ROAD BATH BA2 1EP	PART NO 100P2554-**-**-1-*
1		15/01/2009	NW					
2	5635	09/12/2013						ASSY USED ON MIL-C-83513
								DRAWING NO P9122
					WEIGHT			
					DRAWN	K.SHEPPARD		
					TITLE MICRO MIN MAGNAFORM ADAPTOR ASSEMBLY AND HEATSHRINK BOOT KIT			