



**Main switch Surface mounting**



Powering Business Worldwide™

**Part no.** T0-2-8900/11/SVB  
**Article no.** 207151

**Catalog No.** CT02-8900-11CRQ

**Delivery programme**

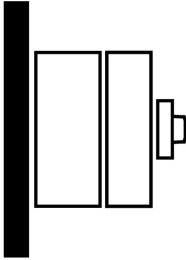
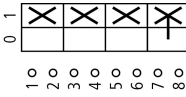
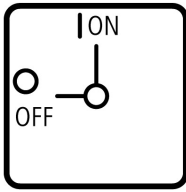
Product range			Switch-disconnectors
Basic function			Main switches Maintenance switches Manual override switches
Part group reference			T0
Design			Surface mounting 
Protection type			IP65 <b>totally insulated</b>
Emergency stop			As an emergency switching off/emergency stop device With red rotary handle and yellow locking ring
Standards			According to IEC/EN 60204-1, VDE 0113 Part 1
Locking facility			Lockable in the 0 (Off) position without auxiliary contacts
Contacts			Neutral pole
Contact sequence			 1 0 2 0 3 0 4 0 5 0 6 0 7 0 8 0
Front plate no.			 <b>FS 908</b>
Main conducting paths			
No. of poles		M	3 + N
Auxiliary contacts		N/O	0
		B	0
Max. motor rating			
AC-23A			
400/415 V 50-60 Hz	P	kW	6.5

Rated uninterrupted current	$I_u$	A	20
-----------------------------	-------	---	----

## General

Standards			IEC/EN 60947, VDE 0660, IEC/EN 60204, CSA, UL Switch-disconnectors to IEC/EN 60947-3 Load-break switches to IEC/EN 60947-3
Lifespan, mechanical	Operations	$\times 10^6$	0.4
Maximum operating frequency		Operations/h	3000
Climatic proofing			Damp heat, constant, to IEC 60068-2-78; Damp heat, cyclical, to IEC 60068-2-30
Ambient temperature		°C	
Open		°C	- 25 - 50
Enclosed		°C	- 25 - 40
Mounting position			As required
Mechanical shock resistance to IEC 60068-2-27	Half-sinusoidal shock 20 ms	g	> 15

## Contacts

Rated operational voltage	$U_e$	V AC	690
Rated impulse withstand voltage	$U_{imp}$	V AC	6000
Overvoltage category/pollution degree			III/3
Rated uninterrupted current	$I_u$	A	
open	$I_u$	A	20
Enclosed	$I_u$	A	20
Load rating with intermittent operation, class 12			
AB 25 % DF		$\times I_e$	2
AB 40 % DF		$\times I_e$	1.6
AB 60 % DF		$\times I_e$	1.3
Short-circuit rating			
Fuse		A gG/ gL	20
Rated short-time withstand current (1 s current)	$I_{cw}$	$A_{rms}$	320
Safe isolation to EN 61140			
between the contacts		V AC	440
Switching angles		°	90 60 45 30
Contact units			11
Double-break contacts			max. 22
Current heat loss per contact at $I_e$		W	0.6

## Terminal capacities

Solid or stranded		mm <sup>2</sup>	1 x (1 - 2.5) 2 x (1 - 2.5)
Flexible with ferrules to DIN 46228		mm <sup>2</sup>	
Flexible with ferrule		mm <sup>2</sup>	1 x (0.75 - 1.5) 2 x (0.75 - 1.5)
Terminal screw			M3.5
Tightening torque		Nm	1

## Switching capacity

AC		$\times U_s$	
Rated making capacity $\cos \varphi = 0.35$		A	130
Rated breaking capacity, motor load switch $\cos \varphi = 0.35$		A	
230 V		A	100
400 V		A	110

500 V		A	80
690 V		A	60
Rated operational current 440 V load-break switch AC-21A	I <sub>e</sub>	A	20
Rating, AC-3 motor load switch	P	kW	
220 V 230 V	P	kW	3
230 V Star-delta	P	kW	4
380 V 400 V	P	kW	4
400 V Star-delta	P	kW	5.5
500 V	P	kW	5.5
500 V Star-delta	P	kW	7.5
660 V 690 V	P	kW	4
690 V Star-delta	P	kW	5.5
AC-23A Motor load switches (main switches maintenance switches)	P	kW	
230 V	P	kW	3.5
400 V	P	kW	6.5
500 V	P	kW	7.5
Rated operational current control switch AC-15			
220 V 230 V 240 V	I <sub>e</sub>	A	6
380 V 400 V 415 V	I <sub>e</sub>	A	4
500 V	I <sub>e</sub>	A	2
DC		x U <sub>s</sub>	
DC-1, Load-break switches L/R = 1 ms			
Rated operational current	I <sub>e</sub>	A	10
Voltage per contact pair in series		V	60
DC-21A	I <sub>e</sub>	A	
Rated operational current 240 V	I <sub>e</sub>	A	1
240 V Contacts		Quantity	1
DC-23A, motor load switch L/R = 15 ms			
24 V			
Rated operational current	I <sub>e</sub>	A	10
Contacts		Quantity	1
48 V			
Rated operational current	I <sub>e</sub>	A	10
Contacts		Quantity	2
60 V			
Rated operational current	I <sub>e</sub>	A	10
Contacts		Quantity	3
120 V			
Rated operational current	I <sub>e</sub>	A	5
Contacts		Quantity	3
240 V			
Rated operational current	I <sub>e</sub>	A	5
Contacts		Quantity	5
DC-13, Control switches L/R = 50 ms			
Rated operational current	I <sub>e</sub>	A	10
Voltage per contact pair in series		V	32
Control circuit reliability at 24 V DC, 10 mA	Fault probability	H <sub>F</sub>	< 10 <sup>-5</sup> , < 1 fault in 100000 operations

### Auxiliary contacts

Standards

According to IEC/EN 60204-1, VDE 0113 Part 1

### Notes

**Notes** Isolating characteristics as specified in IEC/EN 60947 for rated operating voltage U<sub>e</sub> of up to 500 VAC

The following applies for solid, multiwire, and flexible terminal capacities:

If 2 conductors are being used, a max. difference of 2 cross-section categories is permissible

Version as switch disconnector compact			No
Version as main switch			Yes
Version as maintenance-/service switch			Yes
Version as safety switch			No
Version as emergency stop installation			Yes
Max. rated operation voltage Ue AC		V	690
Rated permanent current Iu		A	20
Rated operation power AC-3, 400 V		kW	4
Rated operation power at AC-23, 400V		kW	6,5
Conditioned rated short-circuit current Iq		kA	0
Number of poles			4
Number of auxiliary contacts as normally closed contact			0
Number of auxiliary contacts as normally open contact			0
Number of auxiliary contacts as change-over contact			0
Motor drive optional			No
Motor drive integrated			No
Voltage release optional			No
Device construction			Complete device in housing
Suitable for ground mounting			Yes
Suitable for front mounting			No
Suitable for front mounting center			No
Suitable for distribution board installation			No
Suitable for intermediate mounting			No
Type of control element			-
Interlockable			Yes
Connection type main current circuit			Screw connection
Degree of protection (IP), front side			IP65

## Characteristics

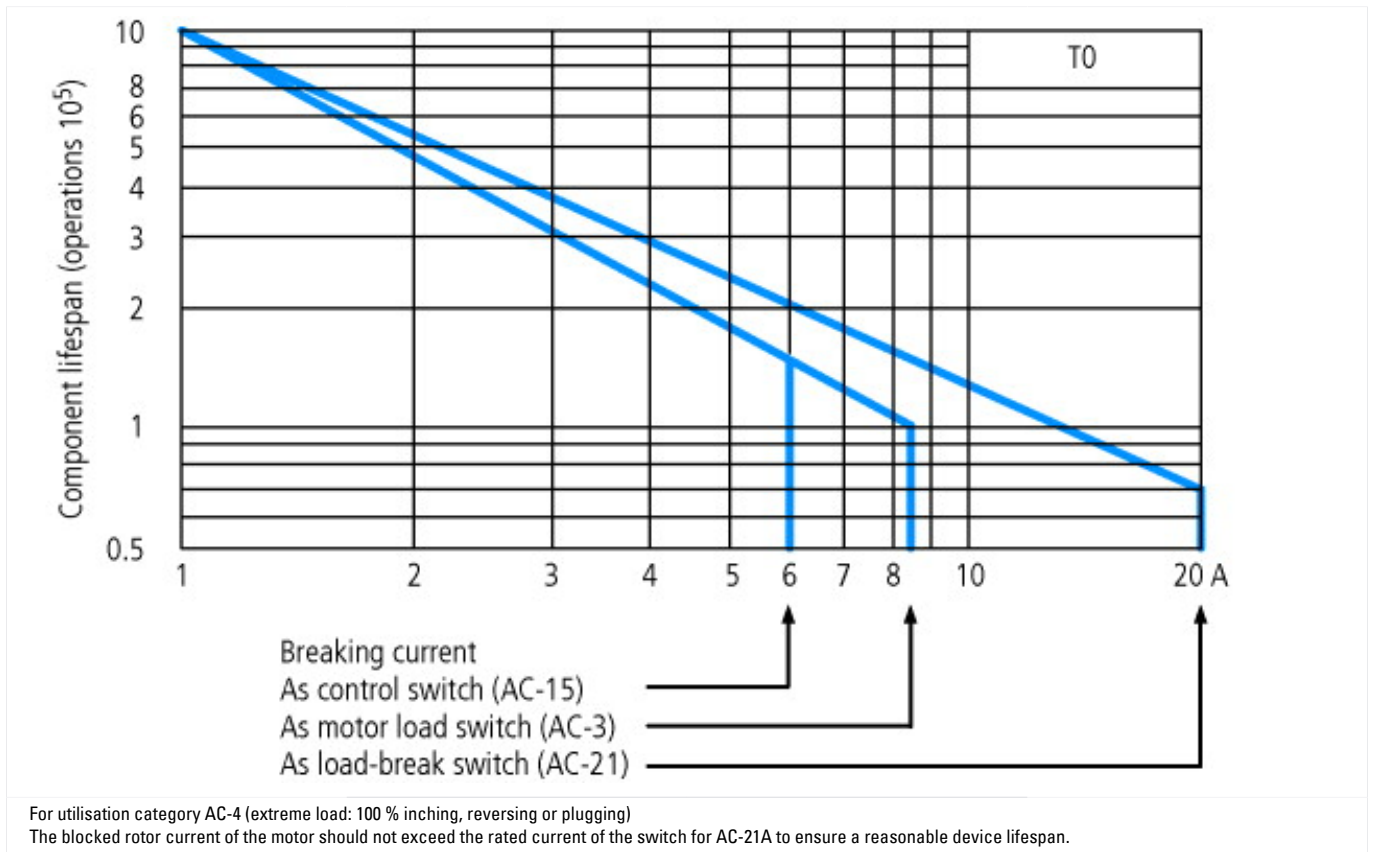

## Dimensions

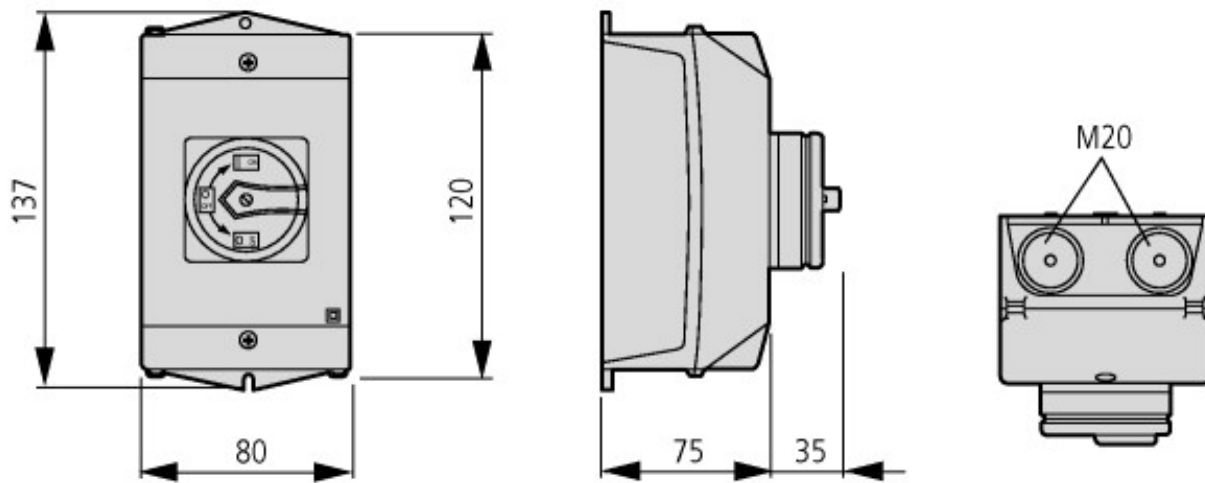

Depth of one contact unit: 9.5 mm

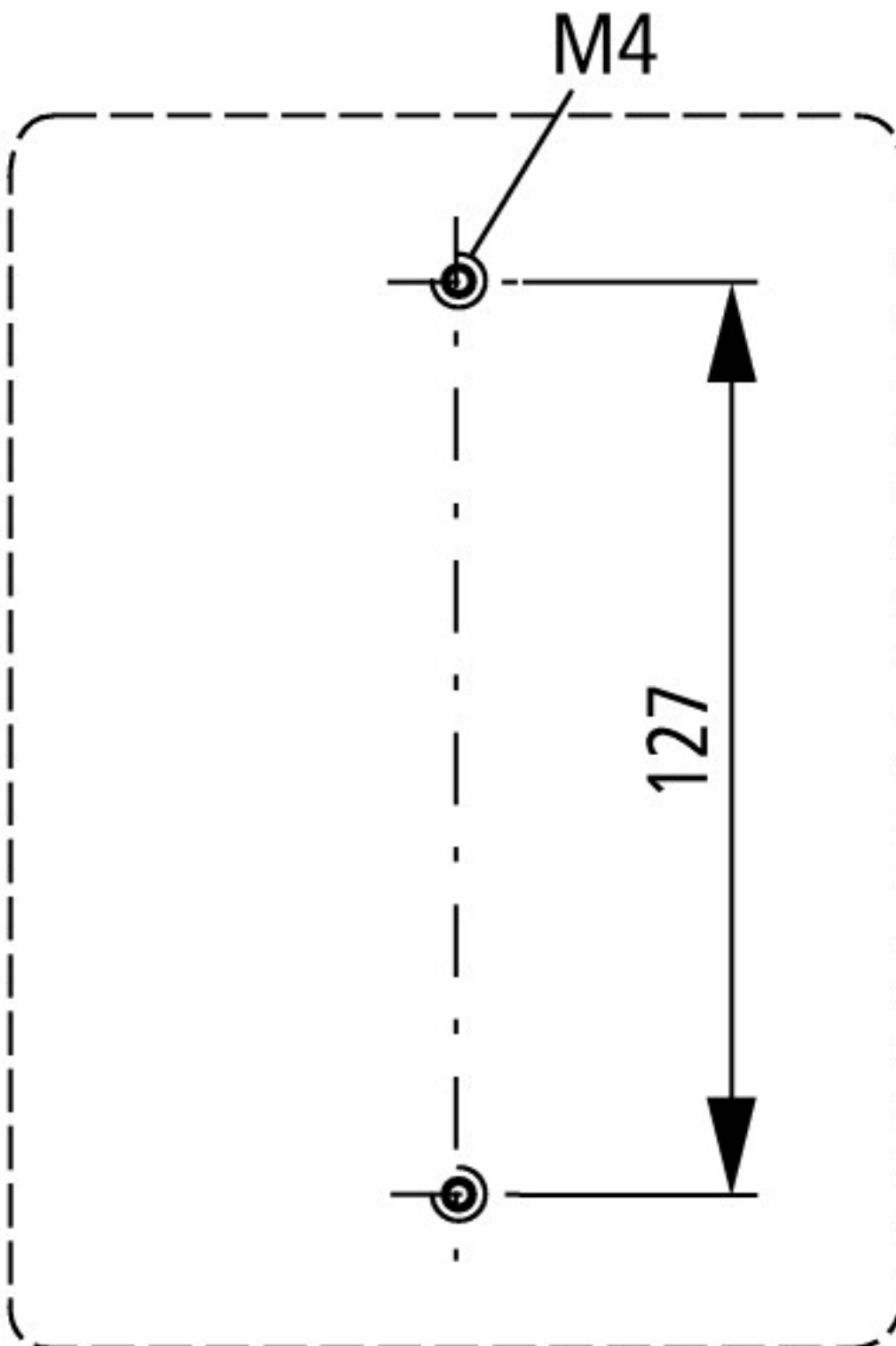

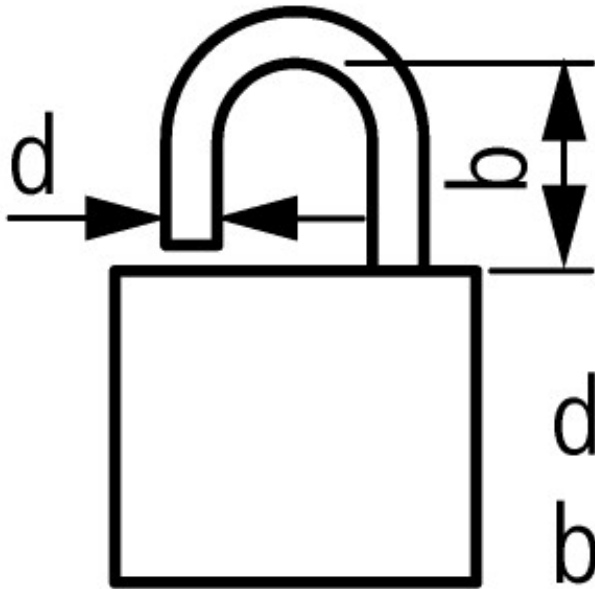

$$d = 4 - 8 \text{ mm}$$
$$b + d \leq 47 \text{ mm}$$

 3 Padlocks

#### Additional product information (links)

**IL03801007Z (AWA1150-1687) Cam switch: Surface mounting enclosure**

IL03801007Z (AWA1150-1687) Cam  
switch: Surface mounting enclosure

[ftp://ftp.moeller.net/DOCUMENTATION/AWA\\_INSTRUCTIONS/IL03801007Z2013\\_02.pdf](ftp://ftp.moeller.net/DOCUMENTATION/AWA_INSTRUCTIONS/IL03801007Z2013_02.pdf)

<http://ecat.moeller.net/flip-cat/?edition=HPLEN&startpage=4.87>