

Cree® XLamp® XB-E High-Voltage White LEDs



PRODUCT DESCRIPTION

Built on Cree’s SC³ Technology™ Platform, XLamp XB-E High-Voltage White (HVW) LED is optimized to lower cost for high-lumen, omnidirectional replacement lamps. The XB-E HVW LED delivers high efficacy in the small XB footprint and enables smaller and more efficient driver circuits than standard-voltage LEDs. In addition, the XB-E LED has a wider light distribution that can improve the omnidirectionality of ENERGY STAR replacement lamps.

FEATURES

- Binned @ 85 °C & 44mA
- Available in 80-minimum CRI
- 125 mA maximum drive current
- 23.5 V typical forward voltage @ 85 °C, 44 mA
- Wide viewing angle: 140°
- Reflow solderable - JEDEC J-STD-020C compatible
- Unlimited floor life at ≤ 30 °C/85% RH
- Electrically neutral thermal path

TABLE OF CONTENTS

Characteristics	2
Flux Characteristics.....	2
Relative Spectral Power Distribution.....	3
Electrical Characteristics	3
Relative Flux vs. Current	4
Typical Spatial Distribution.....	4
Thermal Design	5
Reflow Soldering Characteristics .	6
Notes.....	7
Mechanical Dimensions.....	8
Tape and Reel	9
Packaging.....	10

CHARACTERISTICS

Characteristics	Unit	Minimum	Typical	Maximum
Thermal resistance, junction to solder point	°C/W		6.5	
Viewing angle (FWHM)	degrees		140	
Temperature coefficient of voltage	mV/°C		-19	
ESD classification (HBM per Mil-Std-883D)			Class 2	
DC forward current	mA			125
Reverse voltage	V			0.1
Forward voltage (@ 44 mA, 85 °C)	V		23.5	26.5
LED junction temperature	°C			150

FLUX CHARACTERISTICS (T_j = 85 °C)

The following table provides several base order codes for XLamp XB-E HVW LEDs. It is important to note that the base order codes listed here are a subset of the total available order codes for the product family. For more order codes, as well as a complete description of the order-code nomenclature, please consult the XLamp XB Family Binning and Labeling document.

Color	CCT Range		Base Order Codes Min. Luminous Flux @ 44 mA			Calculated Minimum Luminous Flux (lm)**		Order Code
	Min.	Max.	Group	Flux (lm) @ 85 °C	Flux (lm) @ 25 °C*	66 mA	100 mA	
80 CRI Minimum	4750 K	5000 K	R3	122	140	171	236	XBEHVW-H0-0000-00000HFE3
			R2	114	131	160	221	XBEHVW-H0-0000-00000HEE3
	2700 K	3000 K	Q4	100	118	140	194	XBEHVW-H0-0000-00000HCE7
			Q3	93.9	108	132	182	XBEHVW-H0-0000-00000HBE7

Notes:

- Cree maintains a tolerance of ±7% on flux and power measurements, ±0.005 on chromaticity (CC_x, CC_y) measurements and ±2 on CRI measurements.
- Minimum CRI for 80 CRI Minimum is 80.
- * Flux values @ 25 °C are calculated and are for reference only.
- ** Calculated flux values at 66 mA and 100 mA are for 85 °C and are for reference only.

RELATIVE SPECTRAL POWER DISTRIBUTION

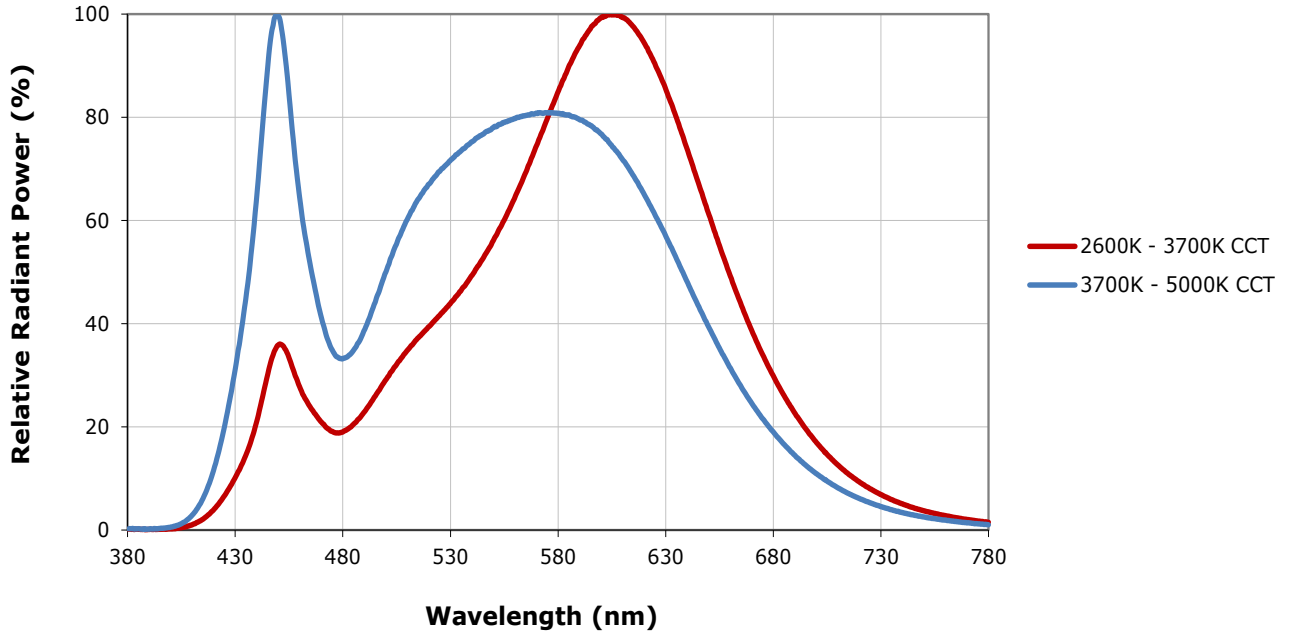

ELECTRICAL CHARACTERISTICS (T_j = 85 °C)

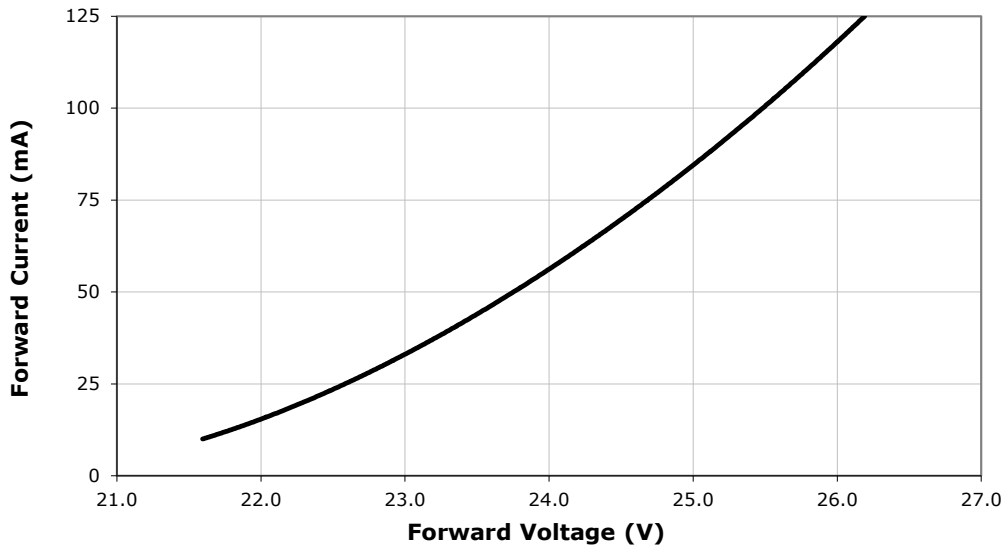

RELATIVE FLUX VS. CURRENT ($T_j = 85\text{ }^\circ\text{C}$)

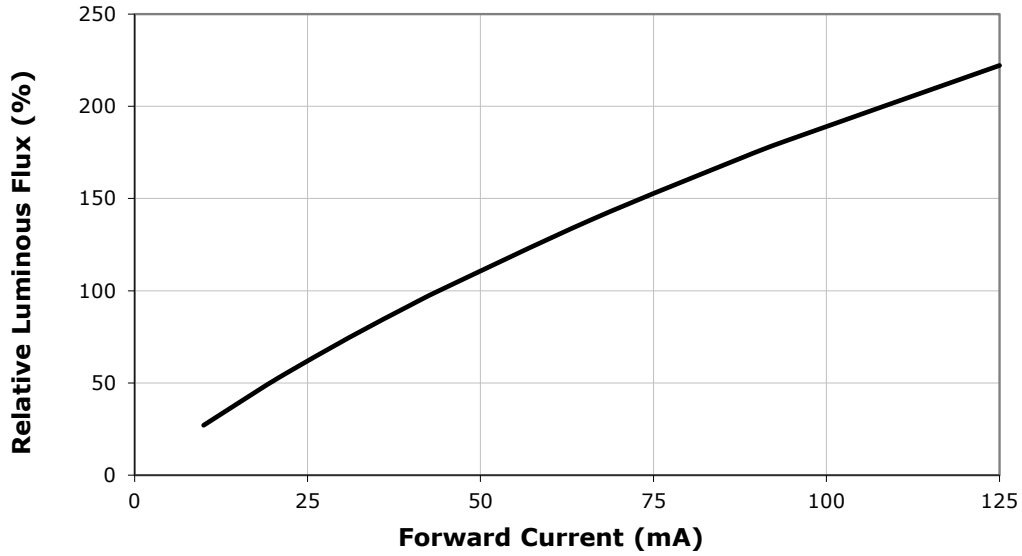

TYPICAL SPATIAL DISTRIBUTION

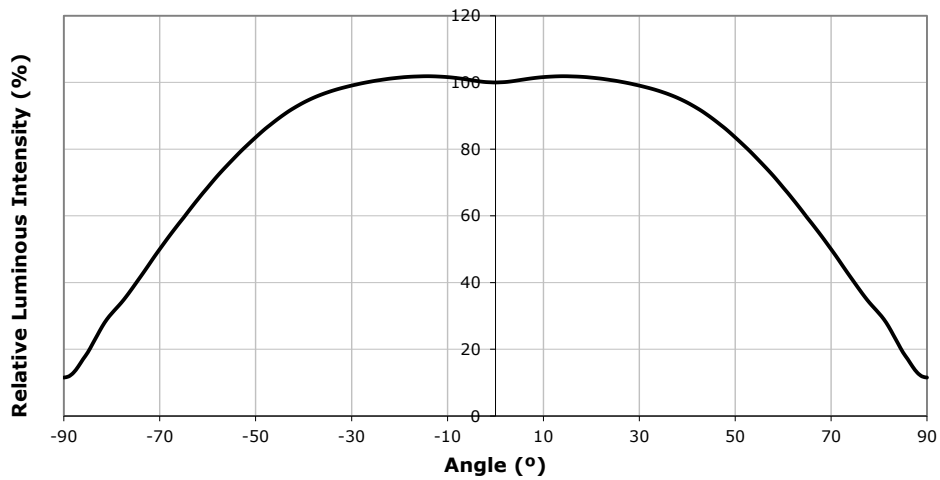

THERMAL DESIGN

The maximum forward current is determined by the thermal resistance between the LED junction and ambient. It is crucial for the end product to be designed in a manner that minimizes the thermal resistance from the solder point to ambient in order to optimize lamp life and optical characteristics.

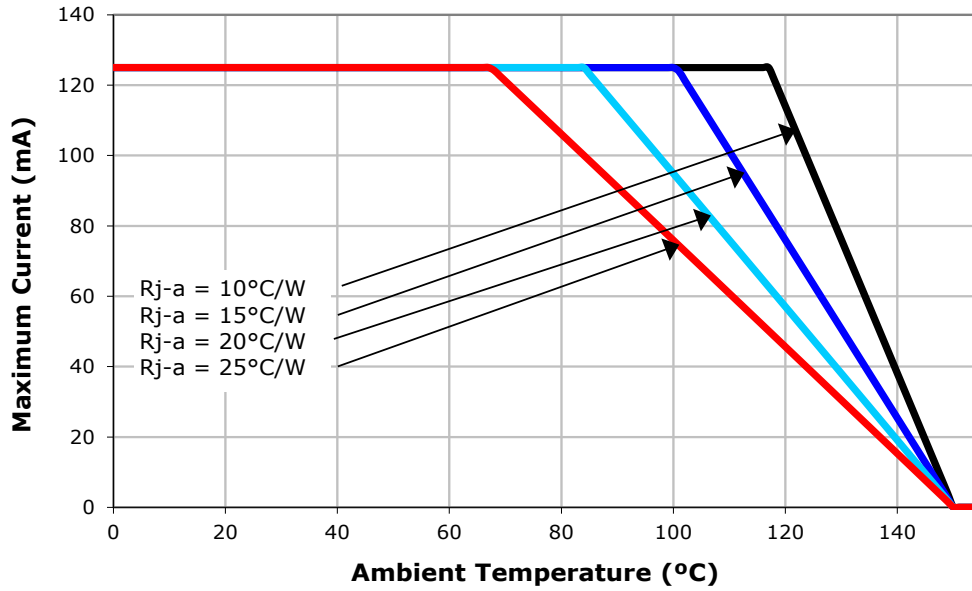

REFLOW SOLDERING CHARACTERISTICS

In testing, Cree has found XLamp XB-E HVW LEDs to be compatible with JEDEC J-STD-020C, using the parameters listed below. As a general guideline, Cree recommends that users follow the recommended soldering profile provided by the manufacturer of solder paste used.

Note that this general guideline may not apply to all PCB designs and configurations of reflow soldering equipment.

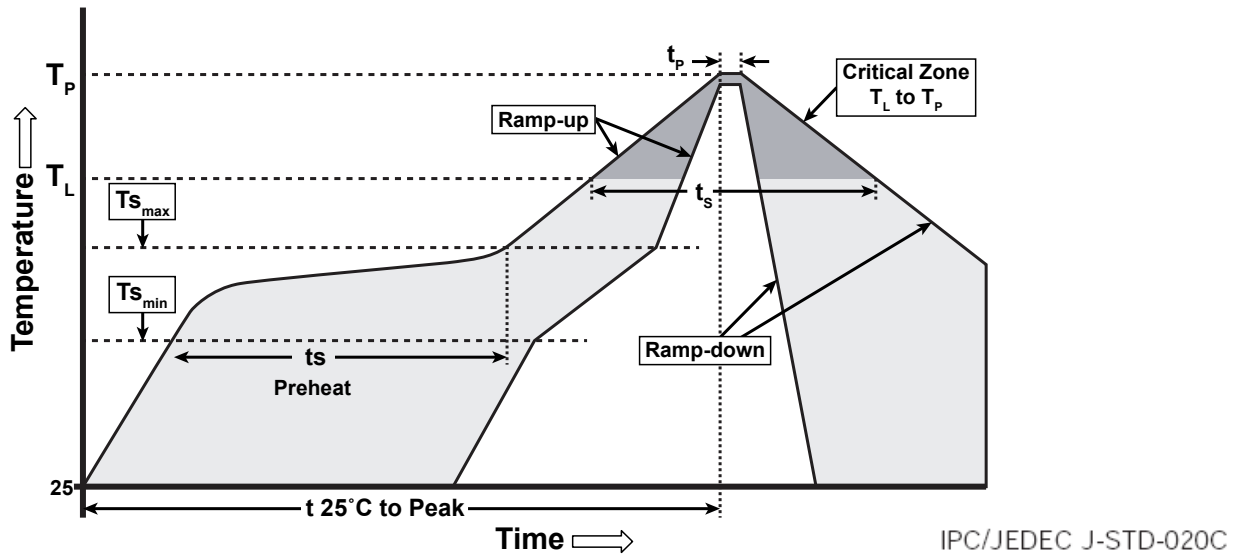

Profile Feature	Lead-Based Solder	Lead-Free Solder
Average Ramp-Up Rate (T_{s_max} to T_p)	3 °C/second max.	3 °C/second max.
Preheat: Temperature Min (T_{s_min})	100 °C	150 °C
Preheat: Temperature Max (T_{s_max})	150 °C	200 °C
Preheat: Time (t_{s_min} to t_{s_max})	60-120 seconds	60-180 seconds
Time Maintained Above: Temperature (T_L)	183 °C	217 °C
Time Maintained Above: Time (t_s)	60-150 seconds	60-150 seconds
Peak/Classification Temperature (T_p)	215 °C	260 °C
Time Within 5 °C of Actual Peak Temperature (t_p)	10-30 seconds	20-40 seconds
Ramp-Down Rate	6 °C/second max.	6 °C/second max.
Time 25 °C to Peak Temperature	6 minutes max.	8 minutes max.

Note: All temperatures refer to topside of the package, measured on the package body surface.

NOTES

Lumen Maintenance Projections

Cree now uses standardized IES LM-80-08 and TM-21-11 methods for collecting long-term data and extrapolating LED lumen maintenance. For information on the specific LM-80 data sets available for this LED, refer to the public LM-80 results document at www.cree.com/xlamp_app_notes/LM80_results.

Please read the XLamp Long-Term Lumen Maintenance application note at www.cree.com/xlamp_app_notes/lumen_maintenance for more details on Cree's lumen maintenance testing and forecasting. Please read the XLamp Thermal Management application note at www.cree.com/xlamp_app_notes/thermal_management for details on how thermal design, ambient temperature, and drive current affect the LED junction temperature.

Moisture Sensitivity

In testing, Cree has found XLamp XB-E HVW LEDs to have unlimited floor life in conditions ≤ 30 °C/85% relative humidity (RH). Moisture testing included a 168-hour soak at 85 °C/85% RH followed by 3 reflow cycles, with visual and electrical inspections at each stage.

Cree recommends keeping XLamp LEDs in their sealed moisture-barrier packaging until immediately prior to use. Cree also recommends returning any unused LEDs to the resealable moisture-barrier bag and closing the bag immediately after use.

Vision Advisory Claim

WARNING: Do not look at exposed lamp in operation. Eye injury can result. See the LED Eye Safety application note at www.cree.com/xlamp_app_notes/led_eye_safety.

MECHANICAL DIMENSIONS

All measurements are ± 0.13 mm unless otherwise indicated.

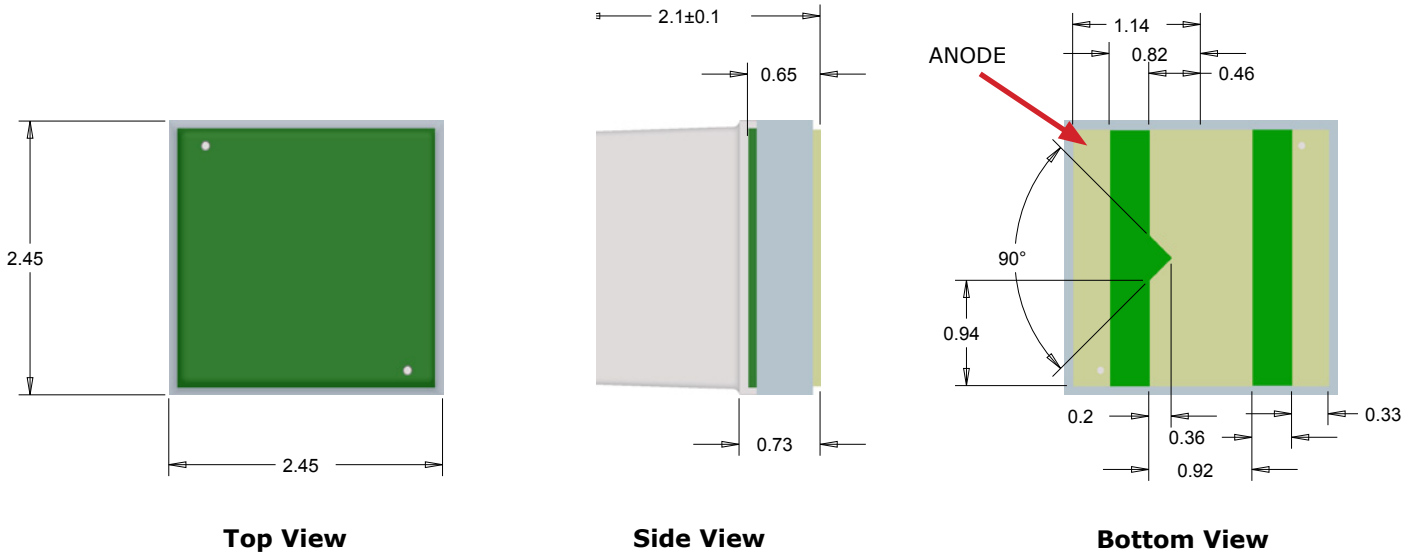

Top View

Side View

Bottom View

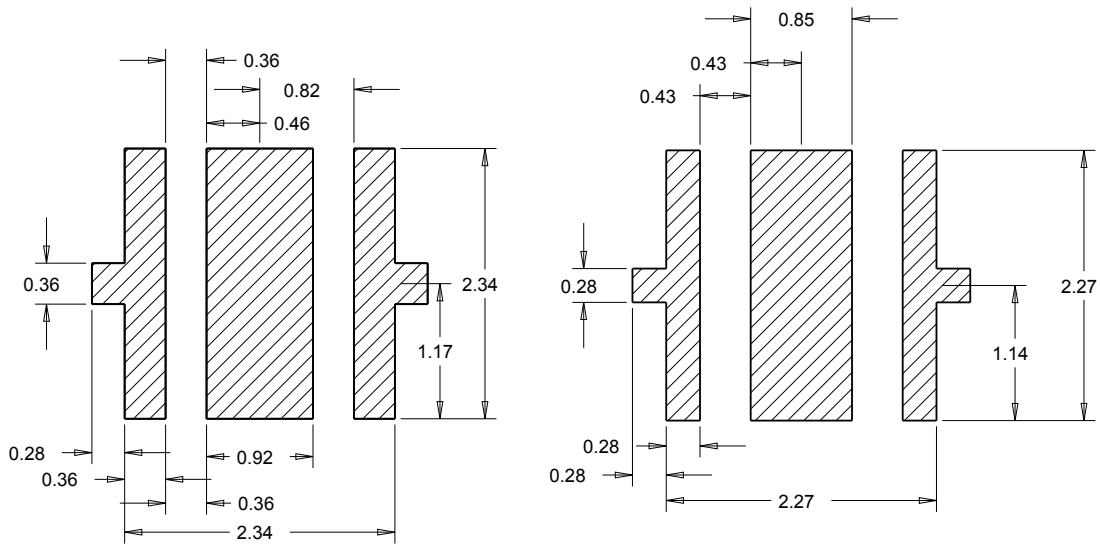

Recommended PCB Solder Pad

Recommended Stencil Pattern

TAPE AND REEL

All Cree carrier tapes conform to EIA-481D, Automated Component Handling Systems Standard.

All dimensions in mm

Tolerance unless specified: .XX ± .25, .XXX ± .125, X° ± .5°

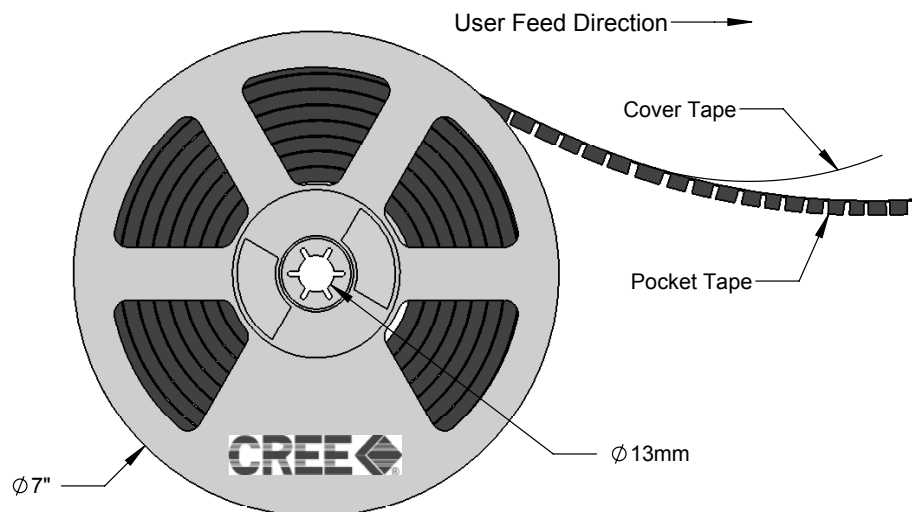
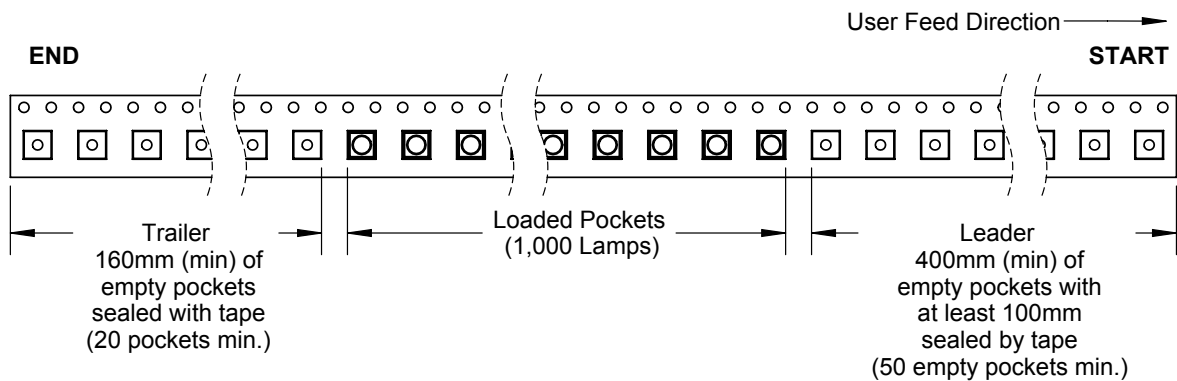
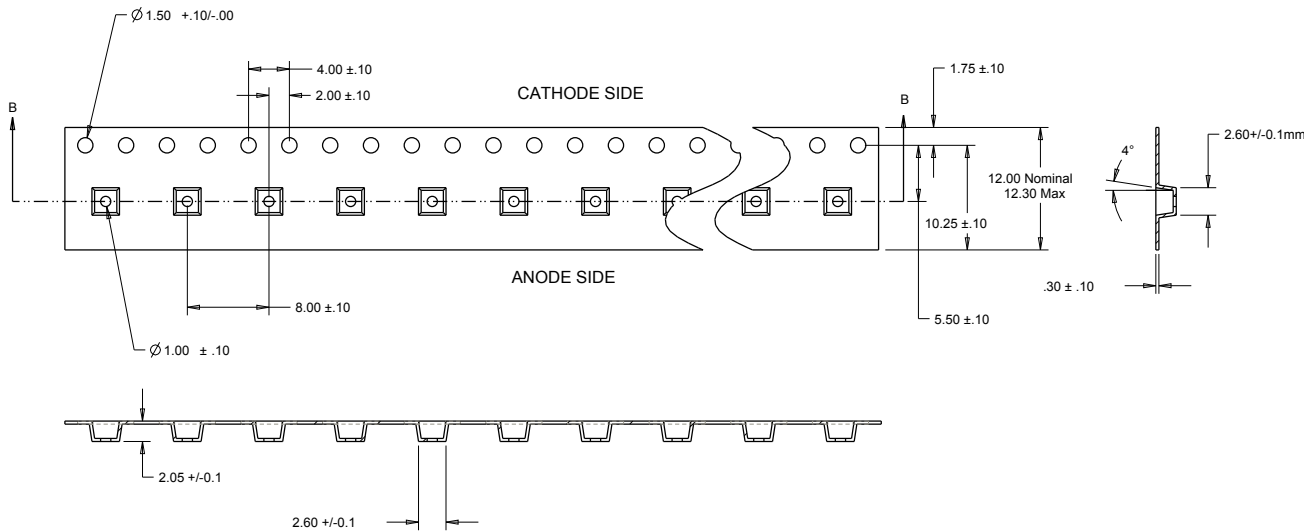

PACKAGING

Unpackaged Reel

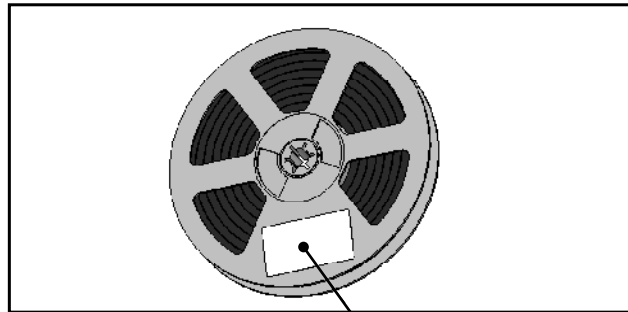

Label with Cree Bin Code, Qty, Reel ID

Packaged Reel

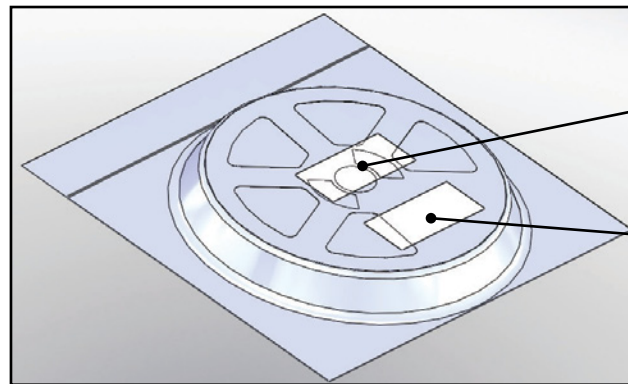

Label with Cree Order Code, Qty, Reel ID, PO #

Label with Cree Bin Code, Qty, Reel ID

Boxed Reel

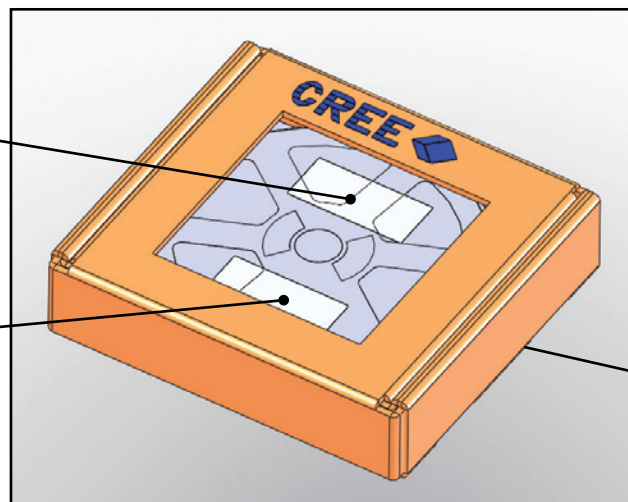

Label with Cree Order Code, Qty, Reel ID, PO #

Label with Cree Bin Code, Qty, Reel ID

Patent Label (on bottom of box)