

I/O module - AXL F DO16/3 2F - 2688048

Please be informed that the data shown in this PDF Document is generated from our Online Catalog. Please find the complete data in the user's documentation. Our General Terms of Use for Downloads are valid (<http://download.phoenixcontact.com>)



Axioline F digital output module, 16 outputs, 24 V DC, 500 mA, 2 or 3-wire connection method (including bus base module and connectors)

Product description

The module is designed for use within an Axioline station.
It is used to output digital signals.
The outputs are protected against short circuit and overload.

Why buy this product

- 16 digital outputs
- 24 V DC, 500 mA
- Connection of actuators in 2 and 3-wire technology
- Minimum update time of < 100 µs, bus synchronous
- Device rating plate stored
- Diagnostic and status indicators



Key commercial data

Packing unit	1 pc
GTIN	 4 046356 501583
Weight per Piece (excluding packing)	283.4 g
Custom tariff number	85389091
Country of origin	Germany

Technical data

Dimensions

Width	53.6 mm
Height	129.9 mm
Depth	54 mm
Note on dimensions	The depth is valid when a TH 35-7.5 DIN rail is used (according to EN 60715).

Ambient conditions

I/O module - AXL F DO16/3 2F - 2688048

Technical data

Ambient conditions

Ambient temperature (operation)	-25 °C ... 60 °C
Ambient temperature (storage/transport)	-40 °C ... 85 °C
Permissible humidity (operation)	5 % ... 95 % (non-condensing)
Permissible humidity (storage/transport)	5 % ... 95 % (non-condensing)
Air pressure (operation)	70 kPa ... 106 kPa (up to 3000 m above sea level)
Air pressure (storage/transport)	70 kPa ... 106 kPa (up to 3000 m above sea level)
Degree of protection	IP20

General

Weight	234 g
Note on weight specifications	with plugs and bus base module
Mounting type	DIN rail
Protection class	III, IEC 61140, EN 61140, VDE 0140-1
Test section	5 V communications power (logic), 24 V supply (I/O) 500 V AC 50 Hz 1 min
	5 V supply (logic)/functional earth ground 500 V AC 50 Hz 1 min
	24 V supply (I/O) / functional earth ground 500 V AC 50 Hz 1 min
Conformance with EMC directives	Noise immunity test in accordance with EN 61000-6-2 Electrostatic discharge (ESD) EN 61000-4-2/IEC 61000-4-2 Criterion B; 6 kV contact discharge, 8 kV air discharge
	Noise immunity test in accordance with EN 61000-6-2 Electromagnetic fields EN 61000-4-3/IEC 61000-4-3 Criterion A; Field intensity: 10 V/m
	Noise immunity test in accordance with EN 61000-6-2 Fast transients (burst) EN 61000-4-4/IEC 61000-4-4 Criterion B, 2 kV
	Noise immunity test in accordance with EN 61000-6-2 Transient surge voltage (surge) EN 61000-4-5/IEC 61000-4-5 Criterion B; DC supply lines: ±0.5 kV/±0.5 kV (symmetrical/asymmetrical)
	Noise immunity test in accordance with EN 61000-6-2 Conducted interference EN 61000-4-6/IEC 61000-4-6 Criterion A; Test voltage 10 V
	Noise emission test according to EN 61000-6-3 Radio interference properties EN 55022 Class B
Mechanical tests	Vibration resistance in acc. with EN 60068-2-6/IEC 60068-2-6 5 g
	Shock in acc. with EN 60068-2-27/IEC 60068-2-27 30 g
	Continuous shock according to EN 60068-2-27/IEC 60068-2-27 10 g
Diagnostics messages	Short-circuit / overload of the digital outputs Yes

Interfaces

Name	Axioline F local bus
Connection method	Bus base module
Transmission speed	100 MBit/s

Axioline potentials

Communications power U_{Bus}	5 V DC (via bus base module)
Current consumption from U_{bus}	max. 120 mA
Supply of digital output modules U_o	24 V DC

I/O module - AXL F DO16/3 2F - 2688048

Technical data

Axioline potentials

Current consumption from U ₀	8 A (external fuse)
---	---------------------

Digital outputs

Output name	Digital outputs
Connection method	Push-in technology
	2, 3-wire
Number of outputs	16
Protective circuit	Short-circuit protection, overload protection of the outputs Electronic
Output voltage	24 V
Nominal output voltage	24 V DC
Maximum output current per channel	500 mA
Maximum output current per module	8 A (external fuse)
Nominal load, inductive	max. 12 VA (1.2 H; 48 Ω; with nominal voltage)
Nominal load, lamp	max. 12 W (at nominal voltage)
Nominal load, ohmic	max. 12 W (48 Ω; with nominal voltage)

Classifications

eCl@ss

eCl@ss 4.0	27240404
eCl@ss 4.1	27240404
eCl@ss 5.0	27242204
eCl@ss 5.1	27242604
eCl@ss 6.0	27242604
eCl@ss 7.0	27242604
eCl@ss 8.0	27242604

ETIM

ETIM 3.0	EC001599
ETIM 4.0	EC001599
ETIM 5.0	EC001599

UNSPSC

UNSPSC 6.01	43172015
UNSPSC 7.0901	43201404
UNSPSC 11	39121311
UNSPSC 12.01	39121311
UNSPSC 13.2	39121311

Approvals

Approvals

I/O module - AXL F DO16/3 2F - 2688048

Approvals

Approvals

UL Listed / cUL Listed / BSH / RINA / GL / DNV / BV / cULus Listed

Ex Approvals

Approvals submitted

Approval details

UL Listed 

cUL Listed 

BSH

RINA

GL

DNV

BV

cULus Listed 

Accessories

Accessories

Connector set

I/O module - AXL F DO16/3 2F - 2688048

Accessories

Connector set - AXL CNS 8L-OBBG/D/UO/E1 - 2700981



AxioLine F plug set (for e.g., AXL F DO16/3 2F)

DIN rail connector

Bus connector - AXL F BS F - 2688129



AxioLine F bus base module for housing type F

Terminal marking

Zack marker strip - ZB 20,3 AXL UNPRINTED - 0829579



Zack marker strip for AxioLine F (device labeling), in 2 x 20.3 mm pitch, unprinted, 25-section, for individual labeling with B-STIFT 0.8, X-PEN, or CMS-P1-PLOTTER

Zack Marker strip, flat - ZBF 10/5,8 AXL UNPRINTED - 0829580



Zack marker strip, flat, in 10 mm pitch, unprinted, 10-section, for individual labeling with M-PEN 0,8, X-PEN, or CMS-P1-PLOTTER

Drawings

I/O module - AXL F DO16/3 2F - 2688048

Dimensioned drawing

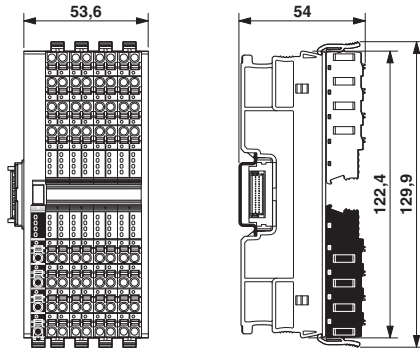

Connection diagram

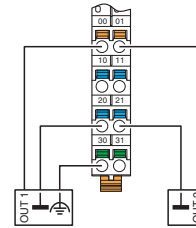

Block diagram

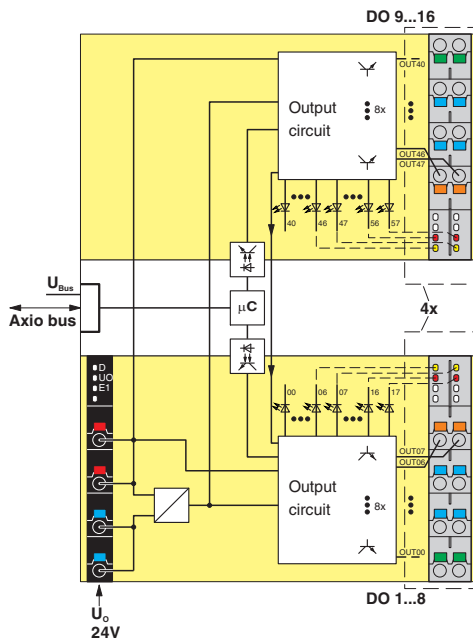

Internal wiring of the terminal points

Diagram

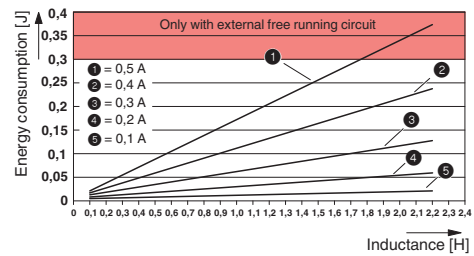

Maximum energy consumption of the outputs when switching off inductive loads
 The diagram shows the maximum amount of energy that may be fed back into the corresponding output groups (outputs 1 to 4, 5 to 8, 9 to 12, 13 to 16) for each switch off procedure when switching off an inductive load without external freewheeling circuit.
 The current data refers to the ohmic DC voltage component of the inductive load.
 Note: Restrict freewheeling voltage to a maximum of -15 V when using an external freewheeling circuit. The external freewheeling circuit has no function in the event of a higher negative voltage.