

Notes:

Castle Pocket Meters

GA213, GA215

and

GA256

Thank you for buying a Castle product, I am sure you will find both the goods and the service to be of the highest quality but if not, then please feel free to write to me personally and I will ensure that your needs are dealt with immediately.

This manual is designed to show you the operation of the goods you have purchased and a very brief insight into acoustics itself. If you would like to become a competent person in the eyes of the law, then you may like to know more about our Competent persons training course for the Noise at Work Regulations.

It is my intention for Castle Group Ltd to provide a complete range of Noise and Vibration products and Services of the highest standard. If you would like to know more about any of our other products and services then please complete the reply paid card and return it to us for prompt action or telephone on +44(0)1723 584250.

Simon Bull



Sales and Marketing Director

Warranty and After Sales Service

Castle Group Ltd design and manufacture precision instruments, which if treated with reasonable care and attention should provide many years of trouble free service.

In the event of a fault occurring, during the warranty period, the instrument should be returned to Castle Group Ltd, in its original packaging, or to an authorised agent. Please enclose a clear description of the fault or symptom.

Details of the warranty cover are available from Castle Group Ltd or an authorised agent.

All instruments are designed to meet rigid British and International Standards. An annual calibration is recommended to ensure that these high standards are maintained. This is particularly important for cases in which instrument readings are to be used in litigation or compliance work.

For warranty and service return to:

The Service Department
Castle Group Ltd
Salter Road
Cayton Low Road Industrial Estate
Scarborough
North Yorkshire
YO11 3UZ

Telephone	+44 (0)1723 584250
Fax	+44 (0)1723 583728
web	www.castlegroup.co.uk

Any misuse or unauthorised repairs will invalidate the warranty.

Damage caused by faulty or leaking batteries is not covered by the warranty.

Case Reflections of the popular range using the Aco 7052 microphone:

Stalk length 75mm from front of microphone grid to top of case body.

Frequency (Hz)	Case Effect (dB)	Frequency (Hz)	Case Effect (dB)
31.5	0.0	800	0.2
40	0.0	1000	0.0
50	0.0	1250	-0.3
63	0.0	1600	-0.2
80	0.0	2000	-0.5
100	0.0	2500	0.4
125	0.0	3150	-0.2
160	0.0	4000	-0.1
200	0.0	5000	0.1
250	0.1	6300	0.1
315	0.1	8000	0.0
400	0.1	10000	0.0
500	0.1	12500	-0.2
630	0.1	16000	0.0

PRECAUTIONS

- Only operate the instruments as described in this manual.
- These are precision instruments, protect from shocks and vibrations.
- Take special care with the microphone. The diaphragm is made from a very thin metal and is easily damaged.
- Ambient conditions for the operation of the unit are as follows:-

Temperature	-10°C to +50°C
Relative Humidity	30 to 90%
- Protect the unit from dust, water, extremes of temperature and humidity, direct sunlight and air with a high salt or sulphur content.
- Always turn the unit off after use. Remove the battery from the instrument if it is not to be used for an extended period (several days).
- Do not use any solvents or cleaning agents on the instrument. Use only a soft dry cloth or a soft cloth lightly moistened with water when necessary.
- Do not let any conductive objects, such as wire or metal scraps get into the unit.
- Do not try to disassemble the instrument or attempt any repairs as this may invalidate your warranty. Take a note of the condition of the instrument and contact your authorised Castle service station.
- To ensure continued precision performance of your instrument have it checked and serviced at regular intervals.

TITLE	CONTENTS	PAGE NO
KEYPAD LAYOUT		1
INTRODUCTION		2
USING THE MANUAL		2
BATTERY INSTALLATION		3
THE MICROPHONE		3
SWITCHING ON AND OFF		4
ACTIVATING BUTTONS		4
CALIBRATION		5
DISPLAYING PARAMETERS		6
LOCKING THE INSTRUMENT		8
CONTRAST CONTROL		8
PAUSING/ PLAYING		8
RESETTING PARAMETERS		9
CHANGING RANGE		10
FREQUENCY/ TIME WEIGHTING		10
CRITERION/ EXCHANGE		11
INSTRUMENT STATUS		12
TECHNICAL SPECIFICATIONS		13
WARRANTY AND AFTER SALES SERVICE		19

Effect of Temperature:

Accuracy better than ± 0.5 dB over the range -10 to +50°C when corrected as indicated here:

The temperature correction to be applied for GA601 / GA607 and microphone:

Corrected level = Actual level – 0.05(t-20)

Where t is the temperature in °C

Effects of Humidity:

Less than 0.5 dB over the range 25 to 90% relative humidity (provided there is no Condensation), relative to the value at 50% relative humidity and 40°C.

Storage range: 0 to 90% relative humidity in the absence of condensation

Vibration:

Effect From 20Hz to 1kHz at 1ms⁻² no noticeable effect

Humidity:

Effect < 0.5 dB from 30% RH to 90% RH

Magnetic Field:

Effect No noticeable effect

Body in Free Field:

Effect No noticeable effect

Windshield:

Attenuation < 0.2 dB

Battery:

1x MN1604 (size PP3) alkaline cell

Life:

20 hours continuous use (approx) based upon bench tests with procell MN1604 batteries

Overall Dimensions:

Dimensions 210mm x 60mm x 35mm (approx.)

Weight

220g including batteries

Crest factor capability:

13 dB at full scale deflection

Signal to Noise ratio:

> 5 dB at bottom of scale

EMC Performance:

Radiated emissions to EN 50 081-2 No significant emissions from the instrument

Calibration Reference Conditions:

- 23°C air temperature
- 50% relative humidity
- 101.325 kPa atmospheric pressure
- 94.0 dB at 1kHz nominal reference level
- 55 – 120dB reference range

Reference direction of incidence for all microphones perpendicular to the front face (diaphragm surface) of the microphone.

Detector Characteristics:

RMS and Peak

Warm up time

< 10 minutes

Operating range

-10°C to +50°C

Warning: DO NOT subject the instrument to temperatures greater than 70°C or less than -20°C for any length of time.

KEYPAD LAYOUT

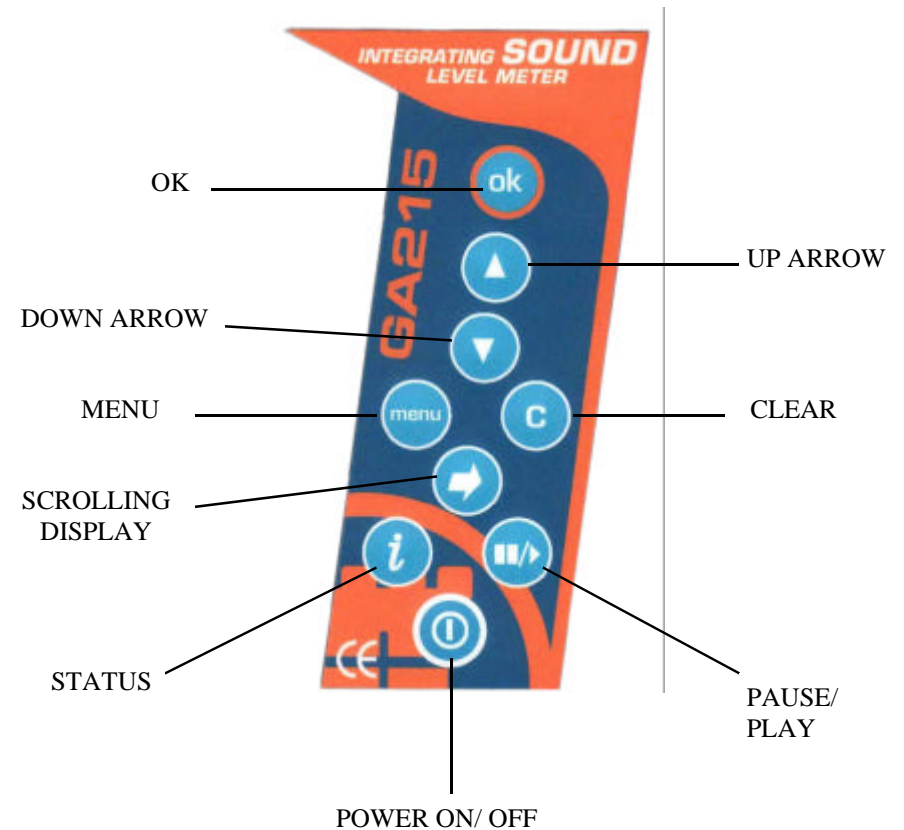

INTRODUCTION

The GA213, GA215 and GA256 are part of Castle's "Pocket Range" of meters and have been designed to surpass the requirements of the new international Class 2 sound level meter standards. They may be used in industry or for general purpose measurement to ascertain noise levels accurately yet economically.

This manual contains complete operating instructions for the above named instruments, read it carefully and you will quickly become familiar with your instrument. If you have problems with the operation of the instrument please call Castle Group Ltd on +44 (0)1723 584250 or fax +44 (0)1723 583728.

USING THE MANUAL

In the course of this manual a named button written in **BOLD** means press that button. E.g. **OK** means press the OK button.

Since this manual covers the operating instructions for three instruments the shaded areas of the title serves to inform the user which functions are present on your instrument.

E.g. The following title informs you that this function is only applicable to the GA213/215

CHANGING RANGE	GA213/215
----------------	-----------

Linear Operating Range:

GA213/GA215 65dB

GA256 67dB

Reference Level:

GA208, GA214 94dB

Reference Range:

GA213/GA215 55 – 120

Reference Frequency:

GA213/GA215 1kHz

Display:

Digital 1 x 8 alphanumeric, digit size 7mm x 5mm Liquid Crystal Display

Microphone:

Aco 1/2" Electret Condenser Microphone Cartridge Type 7052

Type

Diameter (inch)

Response Type

Polarisation (V)

Frequency Range (Hz)

Sensitivity (mV/Pa)

Sensitivity (dB re 1V/Pa)

Capacitance (pF)

Max. Sound Pressure Level (dB)

Temperature Coefficient (dB/°C)

Specification

0.5

Free-Field

0

20 - 8000

25

-32

18

146

-0.01

RMS Frequency Weighting:

- GA213** A and C weightings according to IEC 61672-1 Class 2, IEC60651 Type 2
- GA215** A and C weightings according to IEC 61672-1 Class 2, IEC60651 Type 2
- GA256** A weighting according to IEC 61672-1 Class 2

Time Weightings:

- GA213** S and F according to IEC 61672-1 Class 2, IEC 60651 Type 2
- GA215** S and F according to IEC 61672-1 Class 2, IEC 60651 Type 2

Level Ranges (dB)

	Linear Operating Range (IEC 61672-1 :2002 1kHz)	Primary Indicator Range (IEC 60651 : 2001 1kHz)
GA213/GA215	35 – 100	35 - 93
	55 – 120	55 - 113
	75 – 140	75 - 133
GA256	70 – 137	70 - 130
	Peak Hold Display Range	Display Range
GA213/GA215	63 - 103	34 – 101
	83 - 123	54 – 121
	103 - 143	74 – 141
GA256	100 - 140	69 – 141

(Primary Indicator Range allows for a crest factor of 10dB)

BATTERY INSTALLATION	All
-----------------------------	------------

To prepare the equipment for use a heavy duty alkaline battery type 6LR61 should be fitted, such as a Procell/Duracell MN1604, Ever Ready 6LF22 Gold Seal, or equivalent.

The battery door is located on the bottom left hand side of the instrument. Open the battery door cover by sliding the cover downward towards the bottom of the instrument. The cover will now swing open exposing the battery compartment. Insert the battery observing the correct polarity as marked on the case wall.

Close the battery compartment door by reversing the procedure above. The instrument is now ready for calibration and use.

THE MICROPHONE	All
-----------------------	------------

The microphone capsule fitted to your instrument is a class 2 instrumentation grade 1/2 inch capsule. **The microphone assembly is not removable.** The GA256 is fitted with a DOSE meter microphone assembly in order that it can be attached to the collar of a noise exposed worker.

WARNING: DO NOT TWIST THE MICROPHONE ASSEMBLY

SWITCHING ON AND OFF	All
-----------------------------	------------

Press the **POWER** button and the instrument name appears. Allow the instrument to scroll through its start-up sequence before pressing any other button, this will take approximately 3 seconds.

When the instrument has completed its start-up sequence the display will change to LP (or Lex on GA256) in PAUSED mode using the settings that were last selected.

To switch off, press and release the **POWER** button once and the display goes blank.

ACTIVATING BUTTONS	All
---------------------------	------------

Castle instruments operate with an intuitive menu and status system. The menu is selected by using the dedicated buttons on the keypad. A scrolling menu exists within this function, repeated pressing of the buttons will allow you to scroll through the menu.

The example below shows the status of the instrument. The displayed messages may vary due to different instrument functions and configurations.

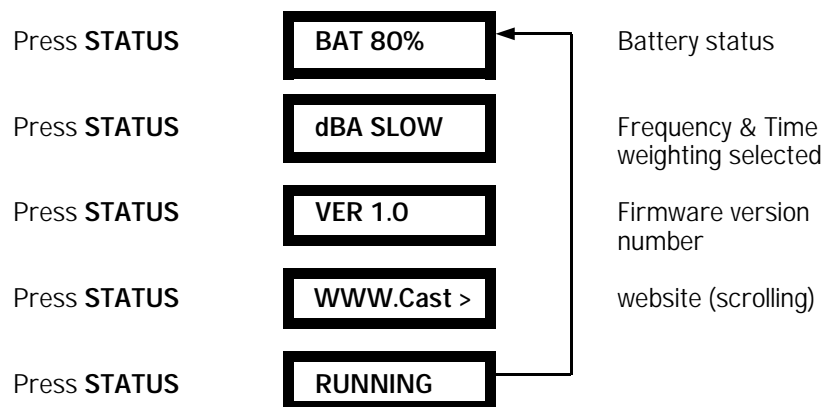

TECHNICAL SPECIFICATION	ALL
--------------------------------	------------

The individual characteristic applies to each instrument unless specifically worded otherwise.

Instrument Standards:

GA213 IEC 61672-1 : 2002 Class 2
IEC 60651 : 2001 Type 2
EN 60651 : 1994 Type 2

GA215 IEC 61672-1 : 2002 Class 2
IEC 60651 : 2001 Type 2
EN 60651 : 1994 Type 2
IEC 60804 : 2000 Type 2
EN 60804 : 2000 Type 2

GA256 IEC 61252 : 2002
EN 61252 : 1997

Measurement Parameters:

GA213 Lp, Lmax, Cpeak, Elapsed time.

GA215 Lp, Leq, Lmax, Cpeak, Lex, Elapsed time, SEL.

GA256 Pa²h, Lex, DOSE, Projected DOSE, DOHR, Cpeak, Projected Lex, Elapsed time,

Peak Frequency Weighting:

GA213 C weighting 20Hz to 20kHz to the tolerances of IEC 61672-1 Class 2

GA215 C weighting 20Hz to 20kHz to the tolerances of IEC 61672-1 Class 2

GA256 C weighting 20Hz to 20kHz

INSTRUMENT STATUS	All
--------------------------	------------

The STATUS button is used to display the status of the instrument.

Press **STATUS**

BAT 80%

Repeatedly pressing the **STATUS** button will scroll through the parameters listed below, depending on the instrument type.

BAT.80%	Percentage battery capacity remaining	ALL
dBA SLOW	Indicates the current frequency and time weighting	GA213/215
VER2.0	Indicates the firmware version number	ALL
RUNNING	Indicates the instrument is running	ALL
PAUSED	Indicates when the instrument is in pause mode (only displayed if instrument is in pause mode)	ALL
90/3	Indicates the current criterion and exchange level	GA256
www.castlegroup.co.uk	Scrolling web-site address	ALL

The STATUS menu is therefore circular and can be easily scrolled through by repeated pressing of the **STATUS** button. Press the **DISPLAY** button at any time to return to normal operation.

This format is repeated for the other functional buttons on your instrument.

CALIBRATION	All
--------------------	------------

The calibrators recommended for use are the Castle GA601/607 calibrators, which supply 94dB/ 104dB (relative to 20µPa pressure) at a frequency of 1kHz.

Turn the instrument on by pressing the **POWER** button.

Press **STATUS** to check the battery condition. Replace the battery if the indication is low.

Press **MENU**

CAL <OK

Press **OK** and the instrument will now display the previous calibration level e.g. >94.0. The calibration will be performed at the selected level e.g.94.0dB but may be changed in 0.1 dB steps to match the calibrator output by repeated pressing of the **UP/DOWN** arrow buttons or in 1dB steps by repeated pressing of the **STATUS/ PLAY** keys. Ensure the calibrator is attached firmly to the microphone. Ensure that the calibrator is set to the chosen level.

Press **OK** and the instrument will calibrate to the level of the calibrator. The display will show **SETTLING** while calibrating to the chosen level. When calibrated the display will show **COMPLETE**. Press **OK** and the display will return to LP for the GA213/215 and DOSE for the GA256.

If the input level is not within +/- 3dB of the chosen reference level then the display will show CAL.FAIL. Check to make sure the calibrator is switched on and emitting the correct level before proceeding as indicated above.

The instrument is now ready to take measurements.

DISPLAYING PARAMETERS	All
------------------------------	------------

The DISPLAY button displays the parameters that are being measured. Repeated pressing of the **DISPLAY** button scrolls round the parameters listed in the table below.

The display will also show the following message when appropriate:

- ** UR ** when the instrument is Under-range
- ** OR ** when the instrument is Over-range.
(Except GA256 since no range change facility present.)

The display will flash when the instrument is Under-range, Over-range or when the Crest factor is being exceeded, indicated by OVERLOAD.
You may leave the display menu by pressing any other button.

The table shown below lists the display parameters available on each of the Popular Range units as they appear by repeated pressing of the **DISPLAY** button.

GA213	GA215	GA256
Lp (SPL)	Lp (SPL)	Lex
Lmx	Leq	Plx
Pmx	Elapsed Time	DO %
Elapsed Time	Lmx	Pr %
Overload (if triggered)	Pmx	Mr %
	Lex	Elapsed Time
	Le	Pmx
	Overload (if triggered)	Psq
		Overload (if triggered)

The table on the following page is a breakdown of the display parameters and is accompanied by an explanation of each one.

CRITERION/ EXCHANGE	GA256
----------------------------	--------------

The Criterion and Exchange level can be changed by the use of the **MENU** button.

Press **MENU** repeatedly until

CRIT/EXC

 is displayed.

Press **OK** and the instrument will display the options available for CRIT/EXC SETUP.

To change the CRIT/EXC use either the up arrow or down arrow button. Pressing either of these two buttons allows you to scroll through the four available criterion and exchange choices, 90/3, 85/3, 90/5, or 85/5.

Note: The symbol > indicates the current selection as you move around the criterion/exchange options.

CHANGING RANGE	GA213/215
-----------------------	------------------

A range change can be performed by the use of the UP/DOWN arrow buttons while in any of the DISPLAY modes (instrument displaying LP dBA etc).

Press **UP ARROW** repeatedly until the required range comes into view, then press **OK** to select.

The instrument will return to the LP screen.

Note: The symbol > indicates the current selection as you move around the range options.

FREQUENCY/ TIME WEIGHTING	GA213/215
----------------------------------	------------------

A change to the frequency and time weightings can be performed by the use of the **MENU** button.

Press **MENU** repeatedly until

WTG < OK

is displayed.

Press **OK** and the instrument will display the options available for WTG SETUP.

To change WTG use either the up arrow or down arrow button. Pressing either of these two buttons allows you to scroll through the four available weighting choices, A SLOW, A FAST, C SLOW or C FAST.

Note: The symbol > indicates the current selection as you move around the weighting options.

DISPLAY	DESCRIPTION	INSTRUMENT
93.7dBC	Level Pressure (Lp)	GA213/215
LEQ 93.7	Displays the LEQ	GA215
00:01:33	Run time duration	All
Lmx 97.3	Maximum Lp	GA215
Pmx 98.8	Maximum Peak	GA213/256
DO % 67	Dose (dependent on exchange and criterion)	GA256
Pr % 0	Displays the projected DOSE assuming an 8 hour shift	GA256
LEX 87.1	Displays the Lex (Lep'd)	GA215
Plx 78.6	Displays the projected Lep'd assuming an 8 hour shift	GA256
Le 93.1	Sound Exposure Level (SEL)	GA215
Hr%	Dose per Hour	GA256
Pa2 0.02	Indicates the energy that has been received in Pa ² hours	GA256
OVERLOAD	Indicates if an OVERLOAD has occurred	All
---.-	Indicates when values are at 0 e.g. when instrument is first powered on or after a reset in PAUSED mode.	All

LOCKING THE INSTRUMENT

ALL

The LOCK feature is used to lock the instrument keypad. All functions are therefore disabled including the POWER button. The function is often used to avoid inadvertent operation or tampering while the instrument is being used.

To LOCK the instrument, press **MENU** until the instrument displays LOCK then press **OK**. The status of the battery will be displayed while the instrument is locked. To UNLOCK the instrument press **CLEAR**, **OK** then **CLEAR** respectively.

CONTRAST CONTROL

ALL

To change to contrast of the meter press **MENU** repeatedly until the display shows CONTRAST. Pressing the UP/DOWN arrow buttons will increase and decrease the contrast. When the desired contrast is reached, press the **DISPLAY** button to return to LP mode.

PAUSING/ PLAYING

ALL

Press **PAUSE/ PLAY** once

PAUSED

All functions can be held so that they do not update by pressing the **PAUSE** button. Once PAUSED, the display may be read as normal allowing the user to take note of any required readings.

For normal operation of the instrument to continue press the **PAUSE/ PLAY** button once more and the instrument will briefly show PAUSED before returning to the currently displayed parameter.

Please note instrument automatically powers on in **PAUSED** mode.

RESETTING PARAMETERS

ALL

The **CLEAR** button is used to reset data.

Press **CLEAR**

CLEAR?

To reset simply press the **OK** button and following message will be displayed:

CONFIRM?

Press **OK** again to reset the data or any other button to decline the RESET.

The instrument then returns to the previously displayed parameter.