



WISMO Series Development Kit User Guide

Wireless Standard M0dem

WA_DEV_W218_UGD_004
001
August 11, 2009

Important Notice

Due to the nature of wireless communications, transmission and reception of data can never be guaranteed. Data may be delayed, corrupted (i.e., have errors) or be totally lost. Although significant delays or losses of data are rare when wireless devices such as the Sierra Wireless modem are used in a normal manner with a well-constructed network, the Sierra Wireless modem should not be used in situations where failure to transmit or receive data could result in damage of any kind to the user or any other party, including but not limited to personal injury, death, or loss of property. Sierra Wireless accepts no responsibility for damages of any kind resulting from delays or errors in data transmitted or received using the Sierra Wireless modem, or for failure of the Sierra Wireless modem to transmit or receive such data.

Safety and Hazards

Do not operate the Sierra Wireless modem in areas where blasting is in progress, where explosive atmospheres may be present, near medical equipment, near life support equipment, or any equipment which may be susceptible to any form of radio interference. In such areas, the Sierra Wireless modem **MUST BE POWERED OFF**. The Sierra Wireless modem can transmit signals that could interfere with this equipment. Do not operate the Sierra Wireless modem in any aircraft, whether the aircraft is on the ground or in flight. In aircraft, the Sierra Wireless modem **MUST BE POWERED OFF**. When operating, the Sierra Wireless modem can transmit signals that could interfere with various onboard systems.

Note: Some airlines may permit the use of cellular phones while the aircraft is on the ground and the door is open. Sierra Wireless modems may be used at this time.

The driver or operator of any vehicle should not operate the Sierra Wireless modem while in control of a vehicle. Doing so will detract from the driver or operator's control and operation of that vehicle. In some states and provinces, operating such communications devices while in control of a vehicle is an offence.

Limitations of Liability

This manual is provided “as is”. Sierra Wireless makes no warranties of any kind, either expressed or implied, including any implied warranties of merchantability, fitness for a particular purpose, or noninfringement. The recipient of the manual shall endorse all risks arising from its use.

The information in this manual is subject to change without notice and does not represent a commitment on the part of Sierra Wireless. SIERRA WIRELESS AND ITS AFFILIATES SPECIFICALLY DISCLAIM LIABILITY FOR ANY AND ALL DIRECT, INDIRECT, SPECIAL, GENERAL, INCIDENTAL, CONSEQUENTIAL, PUNITIVE OR EXEMPLARY DAMAGES INCLUDING, BUT NOT LIMITED TO, LOSS OF PROFITS OR REVENUE OR ANTICIPATED PROFITS OR REVENUE ARISING OUT OF THE USE OR INABILITY TO USE ANY SIERRA WIRELESS PRODUCT, EVEN IF SIERRA WIRELESS AND/OR ITS AFFILIATES HAS BEEN ADVISED OF THE POSSIBILITY OF SUCH DAMAGES OR THEY ARE FORESEEABLE OR FOR CLAIMS BY ANY THIRD PARTY.





Notwithstanding the foregoing, in no event shall Sierra Wireless and/or its affiliates aggregate liability arising under or in connection with the Sierra Wireless product, regardless of the number of events, occurrences, or claims giving rise to liability, be in excess of the price paid by the purchaser for the Sierra Wireless product.

Copyright

© 2009 Sierra Wireless. All rights reserved.

Trademarks

AirCard® and “Heart of the Wireless Machine®” are filed or registered trademarks of Sierra Wireless. Watcher® is a trademark of Sierra Wireless, registered in the European Community. Sierra Wireless, the Sierra Wireless logo, the red wave design, and the red-tipped antenna are trademarks of Sierra Wireless.

   , WAVECOM®, WISMO®, Wireless Microprocessor®, Wireless CPU®, Open AT® are filed or registered trademarks of Wavecom S.A. in France and/or in other countries.

Windows® is a registered trademark of Microsoft Corporation.

QUALCOMM® is a registered trademark of QUALCOMM Incorporated. Used under license.

Other trademarks are the property of the respective owners.

Contact Information

Sales Desk:	Phone:	1-604-232-1488
	Hours:	8:00 AM to 5:00 PM Pacific Time
	E-mail:	sales@sierrawireless.com
Post:	Sierra Wireless 13811 Wireless Way Richmond, BC Canada V6V 3A4	
Fax:	1-604-231-1109	
Web:	www.sierrawireless.com	

Consult our website for up-to-date product descriptions, documentation, application notes, firmware upgrades, troubleshooting tips, and press releases:

www.sierrawireless.com

Document History

Version	Date	Updates
001	August 11, 2009	Creation

>> Contents

1. GENERAL DESCRIPTION.....	11
WISMO Series Development Kit Overview	11
Special Soldering for Jumper Pads	12
RoHS Compliance	12
2. WISMO SERIES DEVELOPMENT KIT	13
WISMO Series Development Kit Top View	14
WISMO Series Development Kit Bottom View	15
Test Ports Available on the WISMO Series Development Kit.....	16
3. WISMO SERIES SOCKET-UP BOARD	20
WISMO Series Socket-Up Board Top View.....	21
WISMO Series Socket-Up Board Bottom View	22
4. SETTING UP THE WISMO SERIES DEVELOPMENT KIT	23
Setting Up the WISMO Series Development Kit.....	23
Power Supply.....	25
Communication Test.....	25
5. INTERFACES/PERIPHERALS	27
Power Supplies.....	27
LED Signalization (“VBAT”)	28
External Supply	28
BAT-TEMP	29
Main Supply Adapter.....	30
Flash LED (“FLASH-LED”, D602)	30
UART1.....	31
UART1 Connector (J100)	31
UART1 Configuration	32
LED Signalization (D100, D101)	33
LED “UART1” (D100).....	33
LED “RING INDICATOR” (D101).....	33
Enabling the UART1 Function (SW101)	33
UART2.....	34
UART2 Connector (J200)	35
UART2 Configuration	36
LED Signalization (D200)	36
Enabling UART2 Function (SW200)	36
Switch “XMODEM” (SW100).....	36

SIM	37
SIM Connector (J400).....	37
Audio	38
AUDIO1 Connector (J701)	38
AUDIO2 Connector (J700)	39
Other Interfaces	42
Power Supply Function	42
Backup Battery Function	42
ADC Function	42
Antenna Function	42
External Board Connector (J1100)	43
WISMO218 and WISMO228 Signals	43
External Board Connector (J1100).....	43
6. ESD PROTECTIONS	48
7. CURRENT CONSUMPTION MEASUREMENT	49
8. SPI INTERFACE FOR DEBUGGING (SPYTRACER TOOL)	52
9. INSTALLING THE WISMO218 OR THE WISMO228 ON THE WMPXXX DEVELOPMENT KIT	55
10. REFERENCE DOCUMENTS	57
11. LIST OF ABBREVIATIONS	58
12. APPENDIX	59
WISMO Series Development Kit	59
WISMO Series Socket-Up Board	73

>> | List of Figures

Figure 1.	WISMO Series Development Kit.....	11
Figure 2.	Jumper Solder Pad.....	12
Figure 3.	WISMO Series Development Kit (Top View)	14
Figure 4.	WISMO Series Development Kit (Bottom View)	15
Figure 5.	WISMO Series Socket-Up Board	20
Figure 6.	WISMO Series Socket-Up Board (Top View)	21
Figure 7.	WISMO Series Socket-Up Board (Bottom View)	22
Figure 8.	Power Supply Voltage (J604 and J600).....	27
Figure 9.	Zoom on “J605”	28
Figure 10.	LED Signalization of “VBAT”	28
Figure 11.	Power Supply Voltage	29
Figure 12.	Main Supply Adapter	30
Figure 13.	FLASH-LED Location	30
Figure 14.	DB-9 Female Connector	31
Figure 15.	RS232 Main Serial Link	32
Figure 16.	LEDs Location (D100, D101).....	33
Figure 17.	UART1 Switch Configuration	34
Figure 18.	Enable UART2 Configuration	35
Figure 19.	RS232 Auxiliary Serial Link.....	36
Figure 20.	XMODEM Switch Configuration (SW100)	37
Figure 21.	SIM Connector	37
Figure 22.	Settings for a Differential Microphone on the WISMO Series Socket-Up Board	39
Figure 23.	Settings for a Differential Microphone on the WISMO Series Development Kit.....	40
Figure 24.	Settings for a Differential Speaker on the WISMO Series Development Kit	40
Figure 25.	Settings for a Single-Ended Microphone on the WISMO Series Socket-Up Board	41
Figure 26.	AUDIO2 Connector.....	41
Figure 27.	SMA Connector on the WISMO Series Socket-Up Board for Customer Applications ..	43
Figure 28.	Configuration of VBATT for Current Consumption Measurement.....	50
Figure 29.	Configuration of the WISMO Series Socket-Up Board for Current Consumption Measurement	50
Figure 30.	WISMO Series Socket-Up Board Settings for an Internal SPI Application.....	52
Figure 31.	SPI Connection to an External Application.....	53
Figure 32.	WMPXXX Development Kit and WISMO Series Socket-Up Board Set-Up	55

Figure 33. WISMO Series Socket-Up Board Assembly (Top View) 73
Figure 34. WISMO Series Socket-Up Board Assembly (Bottom View)..... 73

List of Tables

Table 1.	WISMO Series Development Kit Test Ports	16
Table 2.	LED of "VBAT"	28
Table 3.	Electrical Characteristics of VBATT	29
Table 4.	Electrical Characteristics of BAT-TEMP	29
Table 5.	UART1 Connector Pin Out	31
Table 6.	UART2 Connector Pin Out	35
Table 7.	XMODEM Configuration	37
Table 8.	SIM Connector Pin Out	38
Table 9.	AUDIO2 Connector Pin Out	41
Table 10.	External Board Connector (J1100) Pin Out	43

Overview

This document describes how the WISMO Series Development Kit integrates with the WISMO218 and the WISMO228 via the adaptor board, WISMO Series Socket-Up Board. It discusses the different interfaces within the WISMO Series Development Kit and provides schematics to facilitate the user's understanding and configuration of the development kit for their own use.

The WISMO Series Development Kit is equipment which can be used to develop both software and hardware based on the WISMO218 or the WISMO228. However, it needs to integrate with the WISMO Series Socket-Up Board to function with the WISMO218 or WISMO228.

Refer to the WISMO218 Product Technical Specification and Customer Design Guideline and the WISMO228 Product Technical Specification and Customer Design Guideline for further information about the WISMO218 and the WISMO228.

1. General Description

This section gives a brief overview of the WISMO Series Development Kit and briefly describes the interfaces and special jumper pads available.

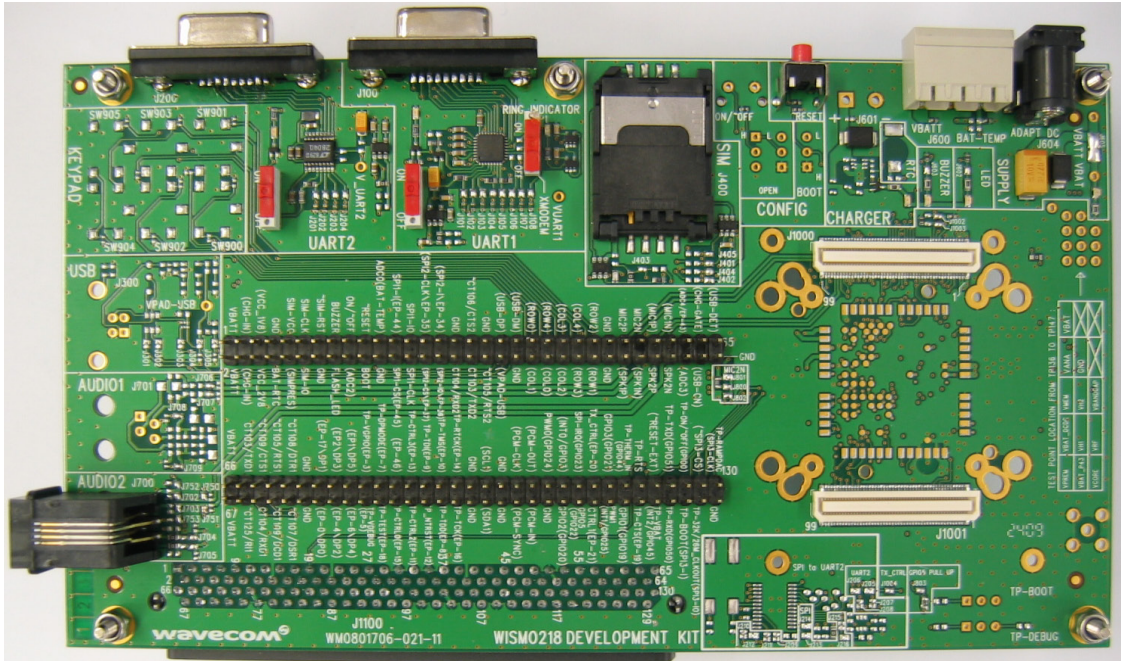

Figure 1. WISMO Series Development Kit

WISMO Series Development Kit Overview

The WISMO Series Development Kit is used to allow users to create and define applications using the WISMO218 or the WISMO228.

Interfaces on the WISMO Series Development Kit which are supported by the WISMO218 and the WISMO228 include:

- 1 external board to board connector and test point (TP) to access all signals for the adaptor board
- Serial link RS232, UART1(*) with full signals
- Ring Indicator
- UART-SPI interface, UART2 connector(*)
- SIM* (1.8/3V)
- 1 Audio connector (AUDIO2)
- LEDs for several indications
- Power supply connectors
- RESET Pushbutton

(*) These signals from the connector side can be electrically disconnected from the WISMO218 or the WISMO228 if the related jumper pads are dissociated. (Refer to the section discussing Special Soldering for Jumper Pads for more information.)

Special Soldering for Jumper Pads

PCB jumper prints are used for the electrical removal of peripherals from the WISMO218 or the WISMO228.

To connect signals between the WISMO218 or the WISMO228 (from J1000 and J1001) and the dedicated connectors on the WISMO Series Development Kit board, solder these PCB jumper prints.

To connect signals between the WISMO Series Socket-Up Board and the external board connector (J1100), it is recommended NOT to solder the PCB prints. Then, a daughter board can be prototyped to connect the WISMO Series Socket-Up Board directly through the board connector (J1100).

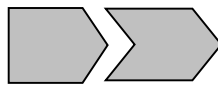

Figure 2. Jumper Solder Pad

The interfaces (or signals) listed below could be electrically removed by dissociating the following PCB jumper prints:

- UART1 (from J101 to J108)
- UART-SPI (UART2 connector, from J201 to J204)
- AUDIO2 (from J702 to J705)
- SIM (from J401 to J405)
- Power supply of the WISMO Series Development Kit interfaces (all components from J605, except the WISMO218 or the WISMO228. For more information, see § 7 Current Consumption Measurement).
- BUZZ-OUT signal (with J603)
- FLASH-LED signal (with J602)

RoHS Compliance

The WISMO Series Development Kit board is compliant with RoHS (Restriction of Hazardous Substances in Electrical and Electronic Equipment) Directive 2002/95/EC which sets limits for the use of certain restricted hazardous substances. This directive states that “from 1st July 2006, new electrical and electronic equipment put on the market does not contain lead, mercury, cadmium, hexavalent chromium, polybrominated biphenyls (PBB) or polybrominated diphenyl ethers (PBDE)”.

Both the WISMO218 and the WISMO228 are compliant with this directive and are identified by the RoHS logo on their labels.



2. WISMO Series Development Kit

This section provides a schematic of both the top and bottom views of the WISMO Series Development Kit. It shows the locations of the several ports and interfaces available, and lists all available test points.

WISMO Series Development Kit Bottom View

The J1101 connector can be used as a daughter board interface when implementing with the WISMO218 or the WISMO228. Please refer to the WMP100 Wireless Microprocessor® Development Kit User Guide for the pin assignments of this external board connector.

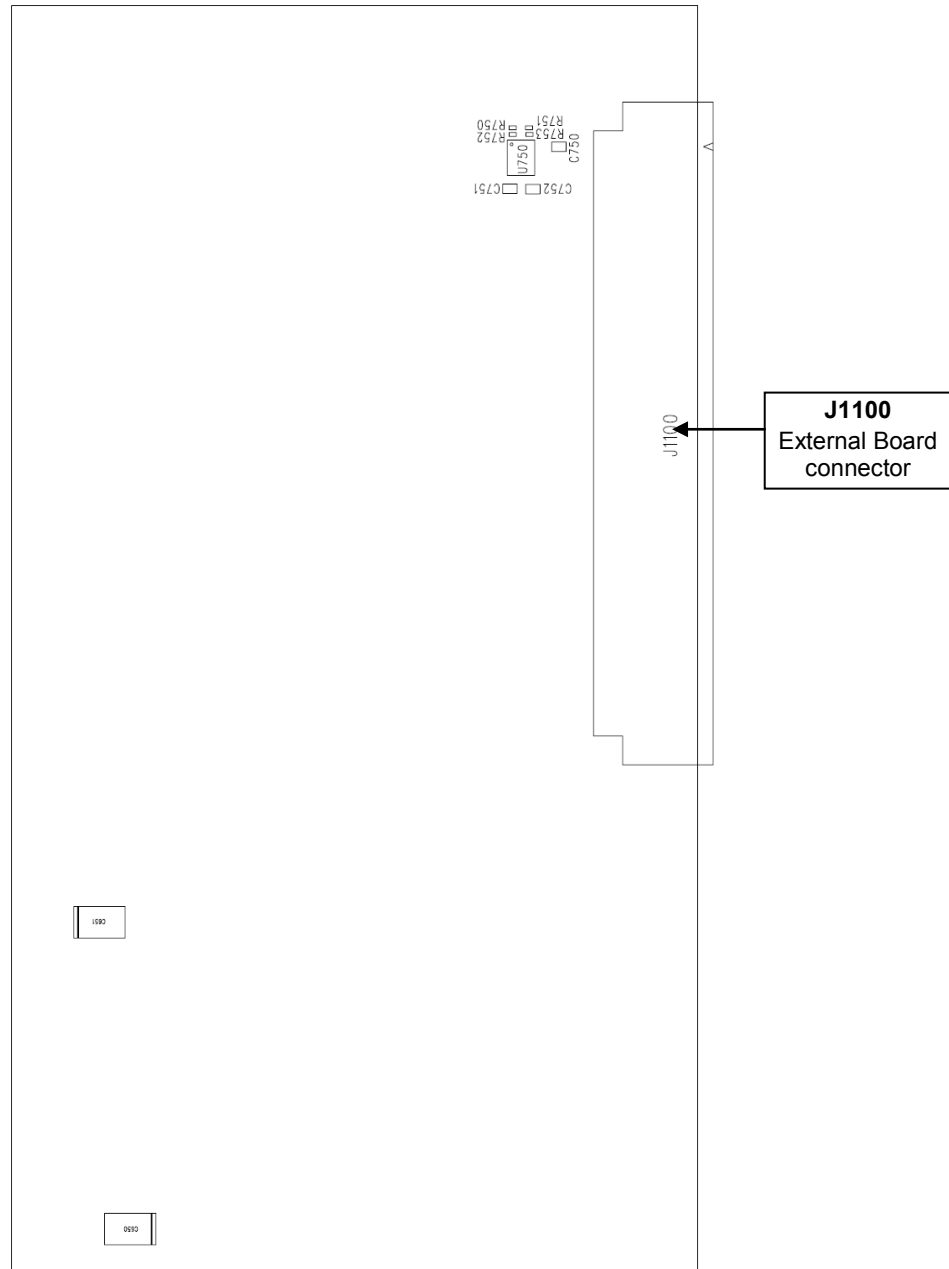

Figure 4. WISMO Series Development Kit (Bottom View)

Test Ports Available on the WISMO Series Development Kit

There are a total of 130 test ports available in the WISMO Series Development Kit. The following table lists the test ports and their corresponding pin assignments.

Table 1. WISMO Series Development Kit Test Ports

Test Port	Pin Assignments
1	VBATT
2	VBATT
3	(CHG-IN)
4	(CHG-IN)
5	(VCC_1V8)
6	VCC_2V8
7	GND
8	BAT_RTC
9	SIM-VCC
10	(SIMPRES)
11	SIM-CLK
12	SIM-IO
13	~SIM-RST
14	GND
15	BUZZER
16	FLASH-LED
17	ON/~OFF
18	(ADC2)
19	~RESET
20	BOOT
21	ADC0(BAT-TEMP)
22	GND
23	SPI1-I(EP-44)
24	SPI1-CS(EP-45)
25	SPI1-IO
26	SPI1-CLK
27	(SPI2-CLK)\EP-35)
28	(SPI2-CS\EP-37)
29	(SPI2-IO\EP-34)
30	(SPI2-IO\EP-36)
31	GND
32	CT104/RXD2
33	~CT106/CTS2
34	CT103/TXD2
35	GND

Test Port	Pin Assignments
36	~CT105/RTS2
37	(USB-DP)
38	(VPAD-USB)
39	(USB-DN)
40	GND
41	(ROW0)
42	(COL1)
43	(ROW4)
44	(COL0)
45	(COL2)
46	(COL3/)
47	(COL4)
48	(ROW3)
49	(ROW2)
50	(ROW1)
51	GND
52	GND
53	MIC2P
54	(SPK1P)
55	MIC2N
56	(SPK1N)
57	(MIC1P)
58	SPK2P
59	(MIC1N)
60	SPK2N
61	(ADC4/EP-43)
62	(ADC3)
63	(CHG-GATE)
64	(USB-CN)
65	(USB-DET)
66	VBATT
67	VBATT
68	CT103/TXD1
69	~CT125/RI1
70	~CT109/CTS1
71	CT104/RXD1
72	~CT105/RTS1
73	~CT109/DCD1
74	~CT108/DTR1
75	~CT107/DSR1
76	GND
77	GND

Test Port	Pin Assignments
78	(EP-17\DP1)
79	(EP-0\DP0)
80	(EP2\DP3)
81	(EP-4\DP2)
82	(EP1\DP5)
83	(EP-6\DP4)
84	TP-VGPIO(EP-3)
85	TP-VDEBUG(EP-5)
86	TP-DPMODE(EP-7)
87	TP-TEST(EP-18)
88	(EP-46)
89	TP-CTRL0(EP-15)
90	TP-CTRL3(EP-13)
91	TP-CTRL2(EP-11)
92	TP-TDI(EP-9)
93	TP_NTRST(EP-12)
94	TP-TMS(EP-10)
95	TP-TDD(EP-8)
96	TP-RTCK(EP-14)
97	TP-TCK(EP-16)
98	GND
99	GND
100	(SCL1)
101	(SDA1)
102	GND
103	GND
104	(PCM-CLK)
105	(PCM-SYNC)
106	(PCM-OUT)
107	(PCM-IN)
108	PWM0(GPIO3)
109	GND
110	(INT0/GPIO3)
111	GPIO2(GPIO20)
112	SPI-IRQ(GPIO23)
113	GPIO5(GPIO22)
114	TX-CTRL(EP-20)
115	CTRL1(EP-21)
116	GPIO3(GPIO21)
117	PWM1(INT1/GPIO25)
118	TP-THERM_IN(GPIO44)
119	GPIO1(GPIO19)

Test Port	Pin Assignments
120	TP-RTS
121	TP-CTS(EP-19)
122	(~RESET-EXT)
123	TP-VBAT(INT2/GPIO45)
124	TP-TXD(GPIO51)
125	TP-RXD(GPIO50)
126	TP-ON/~OFF(GPIO0)
127	TP-BOOT(SPI3-1)
128	(~SPI3-CS)
129	TP-32K/26M_CLKOUT(SPI3-IO)
130	TP-RAMPDAC(SPI3-CLK)

>> 3. WISMO Series Socket-Up Board

Both the WISMO218 and the WISMO228 can't be directly connected onto the WISMO Series Development Kit. An adaptor board, the WISMO Series Socket-Up Board, must be used as an interface between the modules and development kit.

Refer to § 12 Appendix for further information about the implementation of both the WISMO Series Development Kit and the WISMO Series Socket-Up Board.

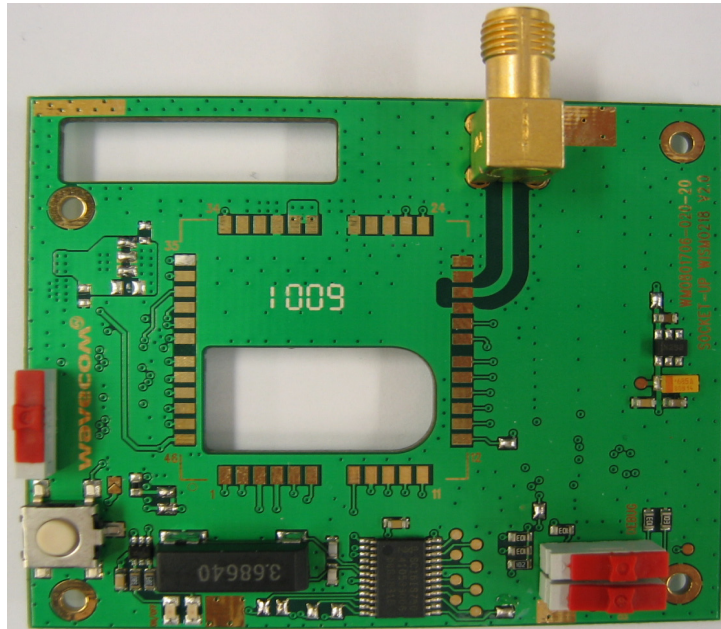

Figure 5. WISMO Series Socket-Up Board

WISMO Series Socket-Up Board Top View

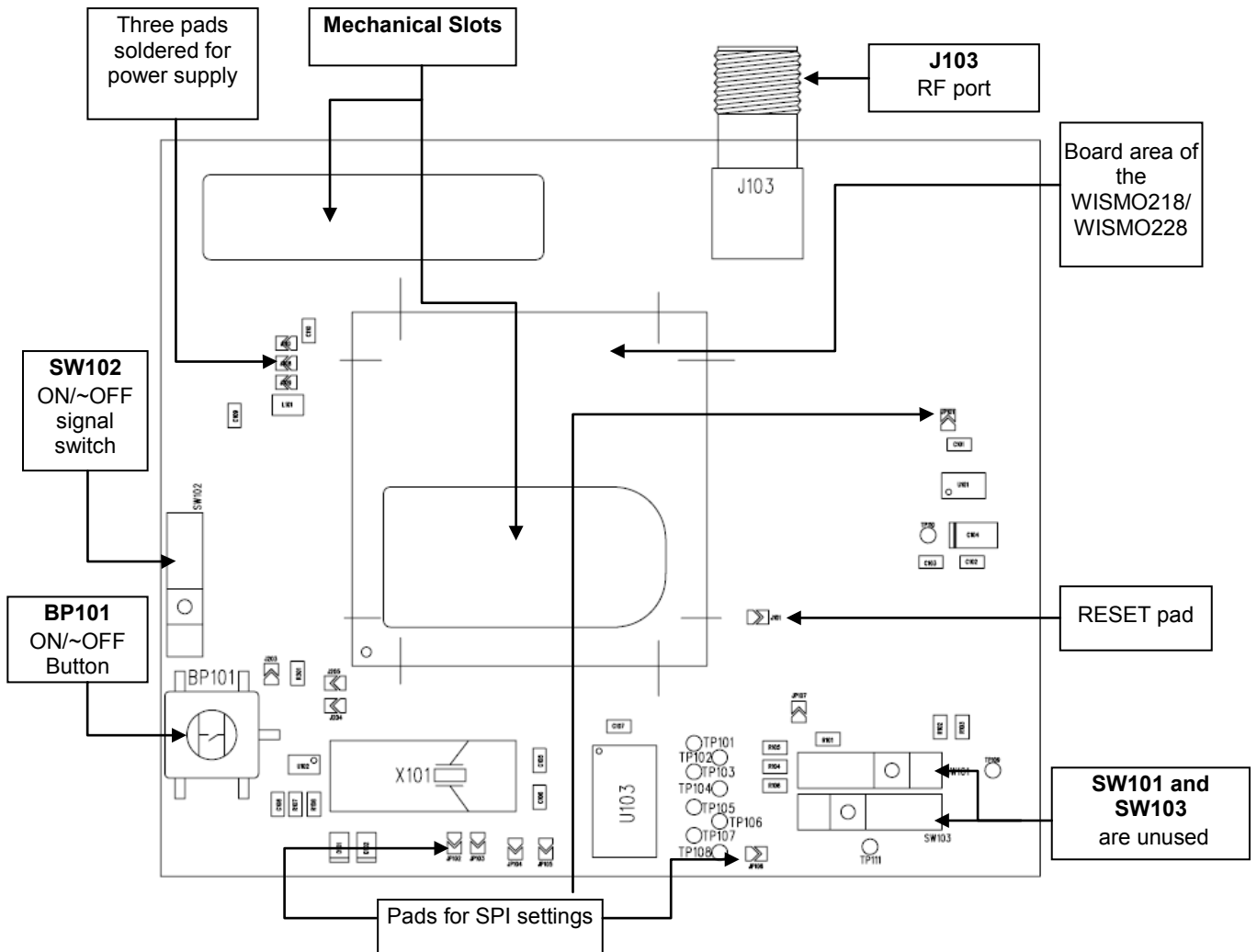

Figure 6. WISMO Series Socket-Up Board (Top View)

WISMO Series Socket-Up Board Bottom View

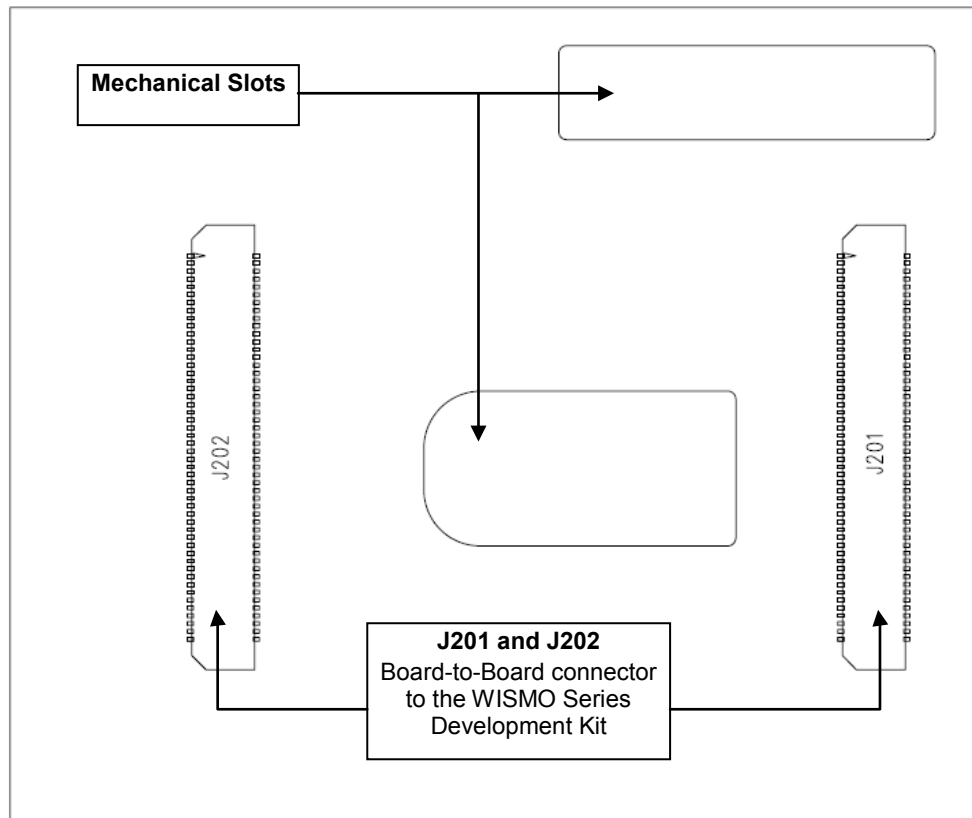

Figure 7. WISMO Series Socket-Up Board (Bottom View)

4. Setting Up the WISMO Series Development Kit

The following section describes how the WISMO Series Development Kit and the WISMO Series Socket-Up Board are setup. It also briefly describes how communication tests are done to ensure that the WISMO218 or the WISMO228 has been properly connected.

Setting Up the WISMO Series Development Kit

Prepare the WISMO Series Development Kit and the WISMO Series Socket-Up Board by following these instructions step by step.

1. Solder the WISMO218 or the WISMO228 onto the WISMO Series Socket-Up Board.
2. Turn SW102 to the "OFF" position.

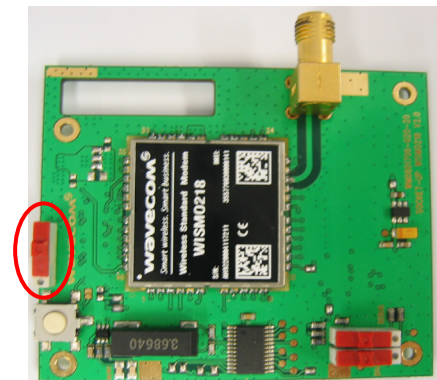
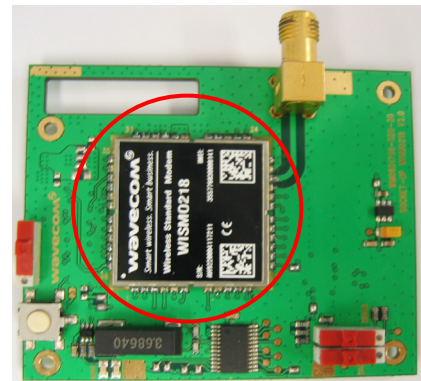

3. Plug the WISMO Series Socket-Up Board on the WISMO Series Development Kit.

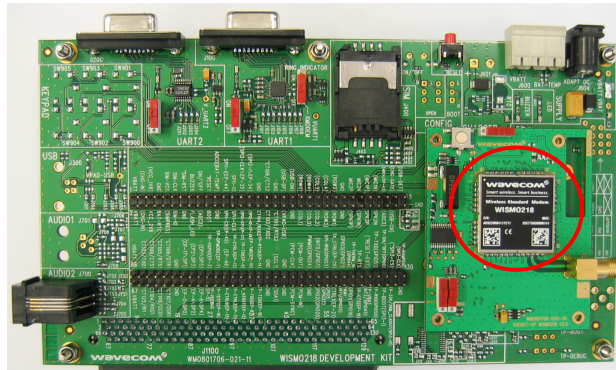

4. Insert a SIM card into the SIM card holder, J400 (if communication is required).

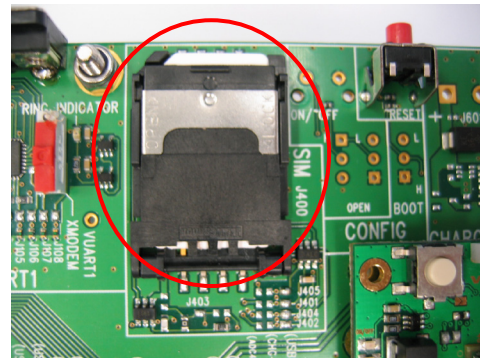

5. All jumper pads are soldered by default. (Refer to the section discussing Special Soldering for Jumper Pads for more information.) Retain these default settings.

6. Connect the RS232 cable between the PC port and J100 of the WISMO Series Development Kit and make sure that SW101 is in the "ON" position.

Note: Baud rate by default is 115200 kbps, 8, N, 1.

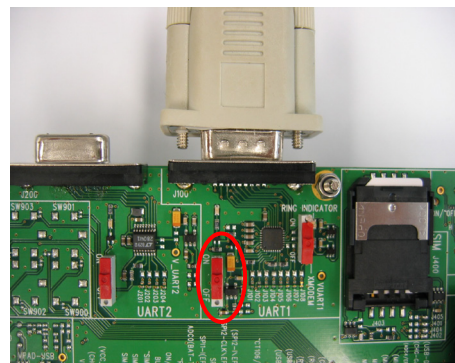

7. If communications is required, connect the J103 SMA connector to an external antenna or a Radio Communication Tester using a coaxial cable.

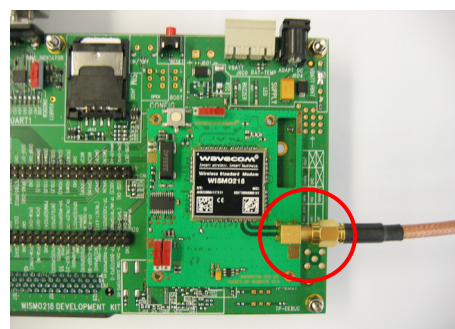

8. If audio communications is required, connect the handset to the Main Audio connector, J700.

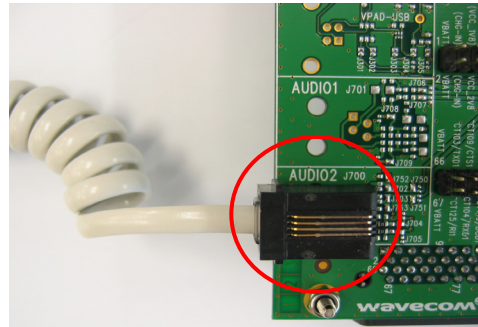

Power Supply

Plug in the AC/DC power supply provided in the J604 connector, or to an external DC power supply at 4V/2A (J600).

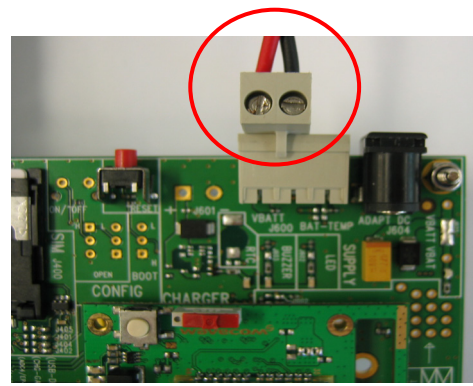

Communication Test

To perform a communication test after setting-up the WISMO Series Development Kit with the WISMO218 or the WISMO228, do the following:

1. Press BP101 to power ON the WISMO218 or the WISMO228.

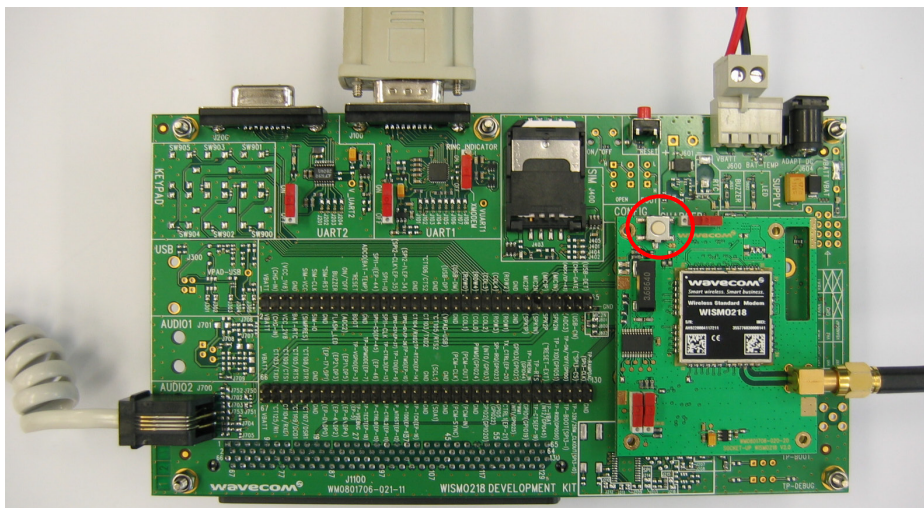

2. Using a PC terminal emulator, send the following command on a serial port to communicate with the WISMO218 or the WISMO228:

AT↵

3. When communication is established between the PC and the WISMO218 or the WISMO228, the command above sends the message "OK" as a reply. Verify that the message is displayed in the terminal emulator window.

Refer to the WISMO218 AT Commands Manual for more information about using AT commands to communicate between a PC and the WISMO Series Socket-Up Board.

5. Interfaces/Peripherals

This section describes the different interfaces/peripherals that are available in the WISMO Series Development Kit.

Power Supplies

Two power supply sources are available on the WISMO Series Development Kit:

- DC external supply (via J600)
- AC/DC adapter (via J604)

These power supplies are protected against electrostatic discharge (ESDs) and voltage or current transient surges by ESD diodes or varistors.

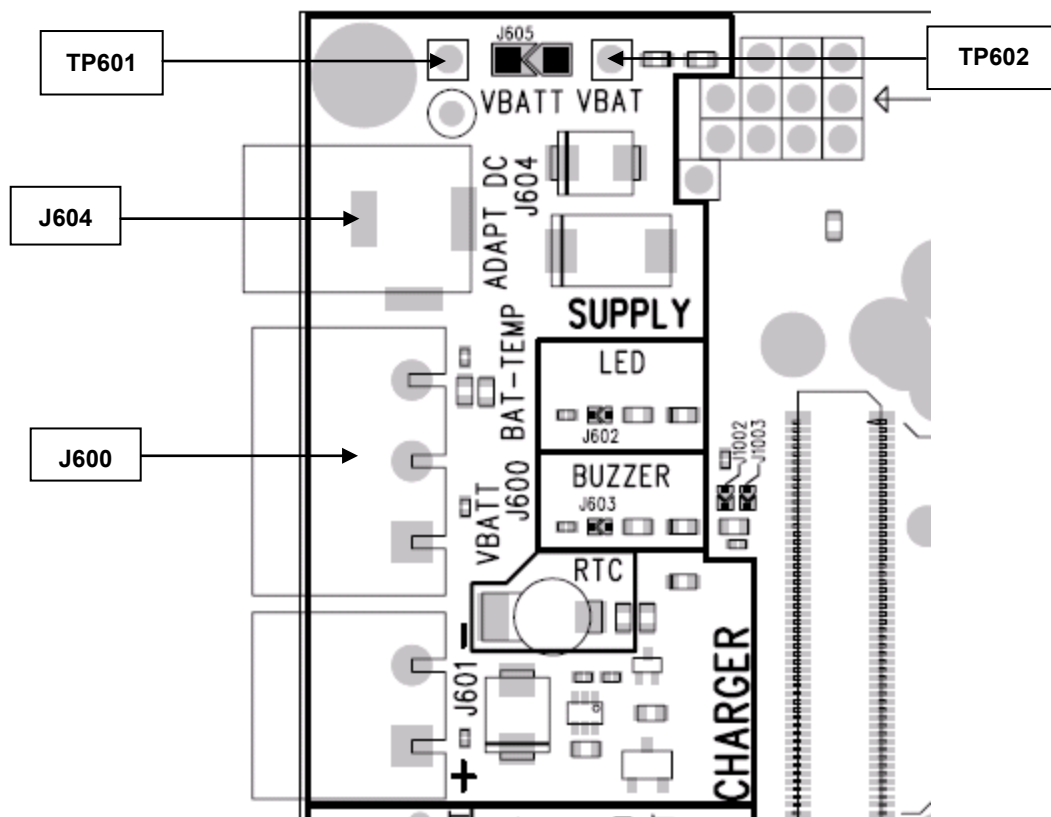

Figure 8. Power Supply Voltage (J604 and J600)

Each of these power supplies are used for *both* the WISMO218 and the WISMO228 and the peripherals on the WISMO Series Development Kit board.

It is possible to separate the power supply for the WISMO Series Socket-Up Board (“VBATT” via TP601) and the power supply for the peripherals (“VBAT” via TP602) by unsoldering J605. Current measurement is therefore possible for the WISMO Series Development Kit and for the WISMO218 or the WISMO228 (refer to § 7 Current Consumption Measurement for more information).

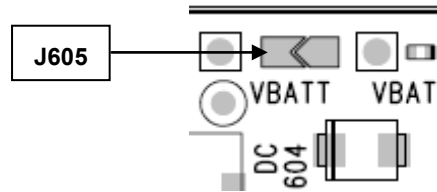

Figure 9. Zoom on “J605”

LED Signalization (“VBAT”)

The “VBAT” indicator is a green LED and it indicates the presence of a power supply at J600 or J604. Both the WISMO218 and the WISMO228 and peripherals are powered by this power source when J605 is soldered. If J605 is unsoldered, an extra external power supply should be connected to “VBAT” for the WISMO Series Development Kit. It is recommended to always use both VBATT and VBAT simultaneously.

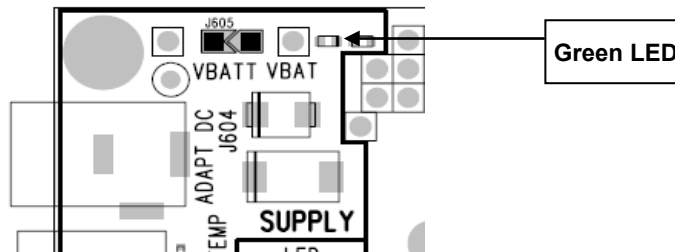

Figure 10. LED Signalization of “VBAT”

Table 2. LED of “VBAT”

LED	VBATT	VBAT
Light ON	ON	ON
Light OFF	Can be ON	OFF

External Supply

The J600 connector has three pins:

- **J600: Pins 1-2** are used to plug the power supply.
- **J600: Pins 2-3** are used to plug in BAT-TEMP. (Refer to the discussion on BAT-TEMP for more information.)

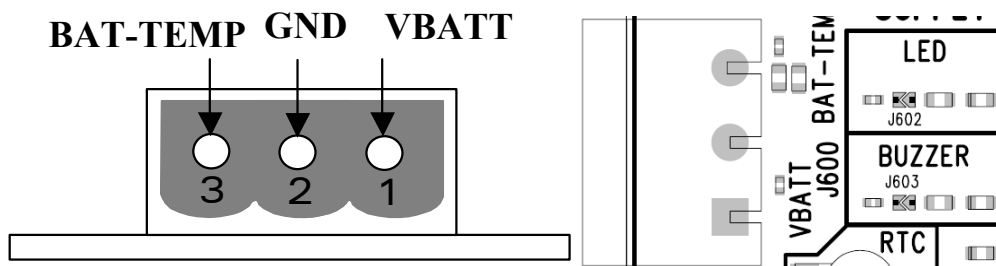

Figure 11. Power Supply Voltage

Table 3. Electrical Characteristics of VBATT

	V_{MIN}	V_{NOM}	V_{MAX}
VBATT ^{1,2}	3.2V	3.6V	4.8V

- 1: This value has to be guaranteed during the burst (with 1.5A Peak in GSM or GPRS mode).
- 2: Maximum operating Voltage Stationary Wave Ratio (VSWR) is 2:1.

For further information, refer to the WISMO218 Product Technical Specification and Customer Design Guideline and the WISMO228 Product Technical Specification and Customer Design Guideline.

BAT-TEMP

The BAT-TEMP signal is an input (ADC) to the WISMO218 or the WISMO228.

J600: Pins 2-3 also allows simulation of the temperature level from a sensor inside the battery

Table 4. Electrical Characteristics of BAT-TEMP

	V_{MIN}	V_{NOM}	V_{MAX}
BAT-TEMP	0	-	3V

For further information, refer to the WISMO218 Product Technical Specification and Customer Design Guideline and the WISMO228 Product Technical Specification and Customer Design Guideline.

Main Supply Adapter

The J604 connector powers the WISMO Series Development Kit using the AC/DC power supply cable.

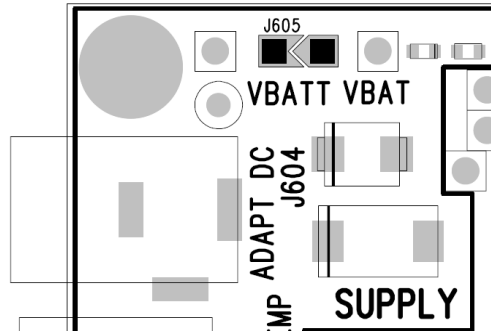

Figure 12. Main Supply Adapter

The only supported adapter is listed in the table below.

Manufacturer	Reference	Characteristics
SINPRO	SPU12C-101	4V DC / 2.5A

Flash LED (“FLASH-LED”, D602)

The “FLASH-LED” location is shown in the following figure.

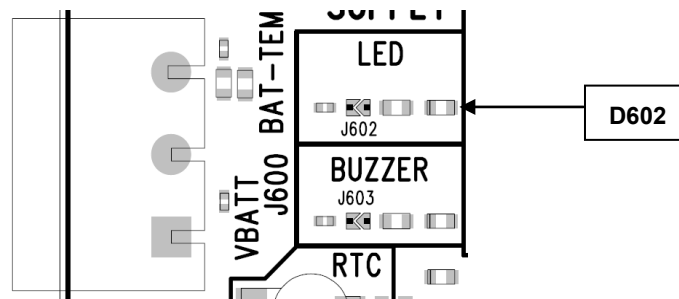

Figure 13. FLASH-LED Location

The “FLASH-LED” indicator, D602, is a green LED that indicates when the WISMO218 or the WISMO228 is in burst mode. The “FLASH-LED” indicates increased current consumption during uplink transmission bursts. However, the lighting might not be clearly visible as the period of each TX burst is very short.

For further information, refer to the WISMO218 Product Technical Specification and Customer Design Guideline and the WISMO228 Product Technical Specification and Customer Design Guideline.

UART1

UART1 of the WISMO Series Development Kit is connected to the RS232 serial link interface of the WISMO218 or the WISMO228. The voltage level of UART1 is 2.8V from the WISMO Series Development Kit side.

The eight UART1 signals in the WISMO Series Development Kit could be electrically disconnected from the WISMO218 or the WISMO228 if the eight tie pads, J101 to J108, are dissociated. Unsoldering them allows the UART1 signals to transmit via the external connector (J100) to an external interface board.

The UART1 is available by default on its dedicated connector, J100; as J101 to J108 are soldered.

UART1 Connector (J100)

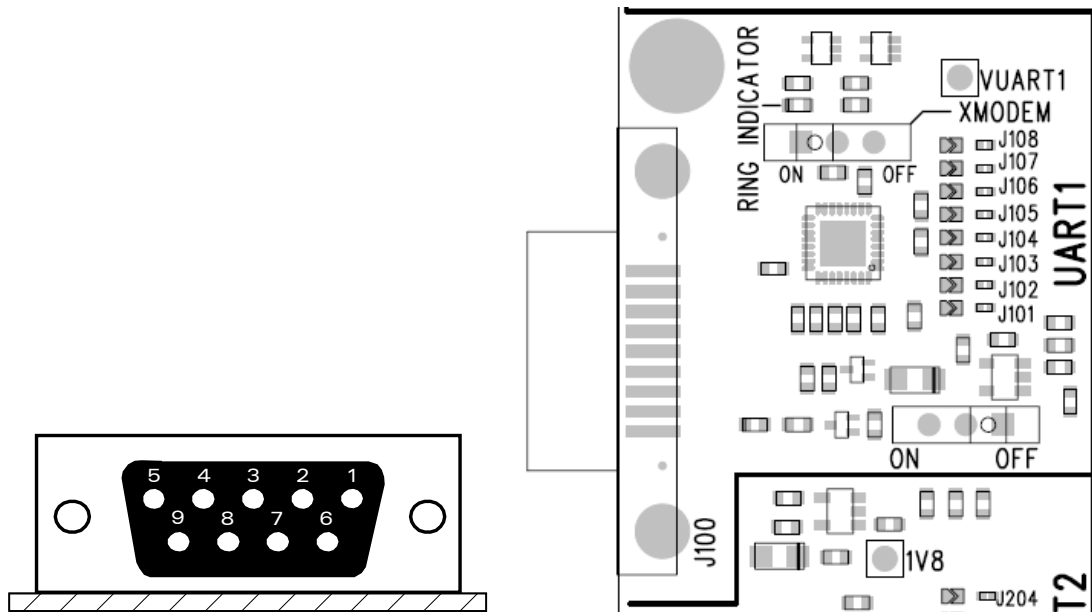

Figure 14. DB-9 Female Connector

J100 is a SUB-D 9-pin female connector. Connector signal details for the J100 are listed in the table below.

Table 5. UART1 Connector Pin Out

Pin #	Signal Name	I/O	I/O Type	Description
1	CT109 DCD	O	RS232 (V24/V28)	Data Carrier Detect
2	CT104 RXD	O	RS232 (V24/V28)	Receive serial data
3	CT103 TXD	I	RS232 (V24/V28)	Transmit serial data
4	CT108-2 DTR	I	RS232 (V24/V28)	Data Terminal Ready
5	GND			Ground
6	CT107 DSR	O	RS232 (V24/V28)	Data Set Ready

Pin #	Signal Name	I/O	I/O Type	Description
7	CT105 RTS	I	RS232 (V24/V28)	Request To Send
8	CT106 CTS	O	RS232 (V24/V28)	Clear To Send
9	CT125 RI	O	RS232 (V24/V28)	Ring Indicator

UART1 Configuration

The WISMO Series Development Kit acts as a DCE and is connected to a DTE (PC or terminal) with a “straight cable”. This is a full UART.

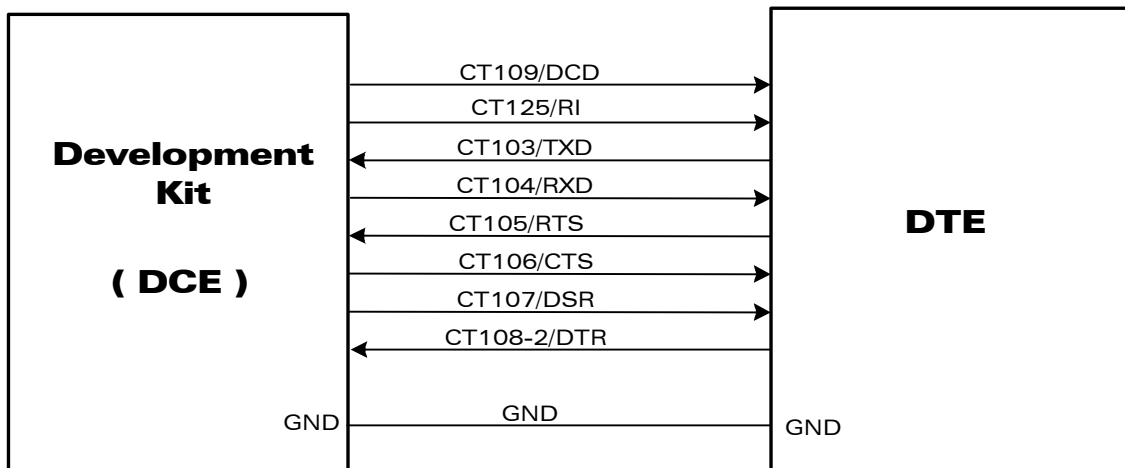

Figure 15. RS232 Main Serial Link

LED Signalization (D100, D101)

The LED signalization locations are shown in the following figure.

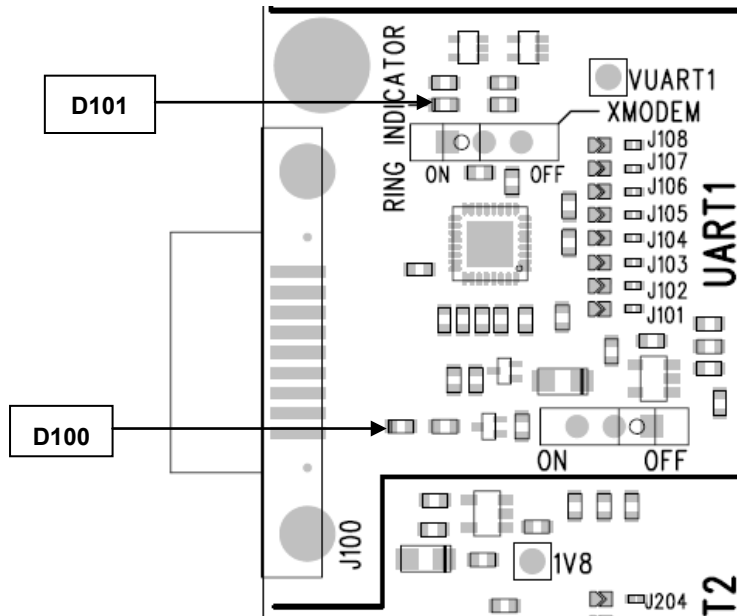

Figure 16. LEDs Location (D100, D101)

LED “UART1” (D100)

This green LED indicates the power supply state of UART1.

The interface can be used when it is lit, depending on which power supply is present (J600 or J604. Refer to the section discussing Power Supplies for more information).

LED “RING INDICATOR” (D101)

The “RING INDICATOR” indicator is a yellow LED controlled by the RI signal on the WISMO218 or the WISMO228.

When the WISMO218 or the WISMO228 receives an incoming call, the RI signal goes from high to low for 0.5sec alternately, hence making the D101 LED blink

Enabling the UART1 Function (SW101)

The UART1 interface can be enabled by switching SW101 to the “ON” position. Please refer to the following figure.

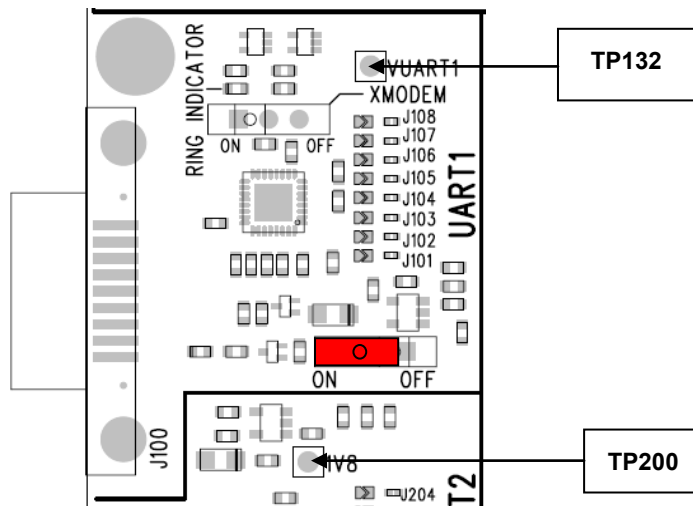

Figure 17. UART1 Switch Configuration

UART2

This interface is reserved for the software debugging tool, Spytracer. Please refer to § 8 SPI Interface for Debugging (Spytracer Tool) for more information. The UART2 in the WISMO Series Development Kit is provided by an SPI-to-serial converter, SC16IS750, in the WISMO Series Socket-Up Board. It interfaces with the SPI interface of the WISMO218 or the WISMO228 and performs SPI-to-serial conversion on data characters.

The four UART2 signals from the WISMO Series Socket-Up Board could be disconnected by dissociating the solder pads J201 to J205. Dissociating the four pads allows for transmission of undisturbed signals via the external connector (J1100) to an external interface board.

By default, the UART2 is available on its dedicated connector J200 (J201 to J204 soldered).

Please refer to the WISMO218 Product Technical Specification and Customer Design Guideline and the WISMO228 Product Technical Specification and Customer Design Guideline for detailed information on the characteristics of the SPI interface of the WISMO218 and the WISMO228.

UART2 Connector (J200)

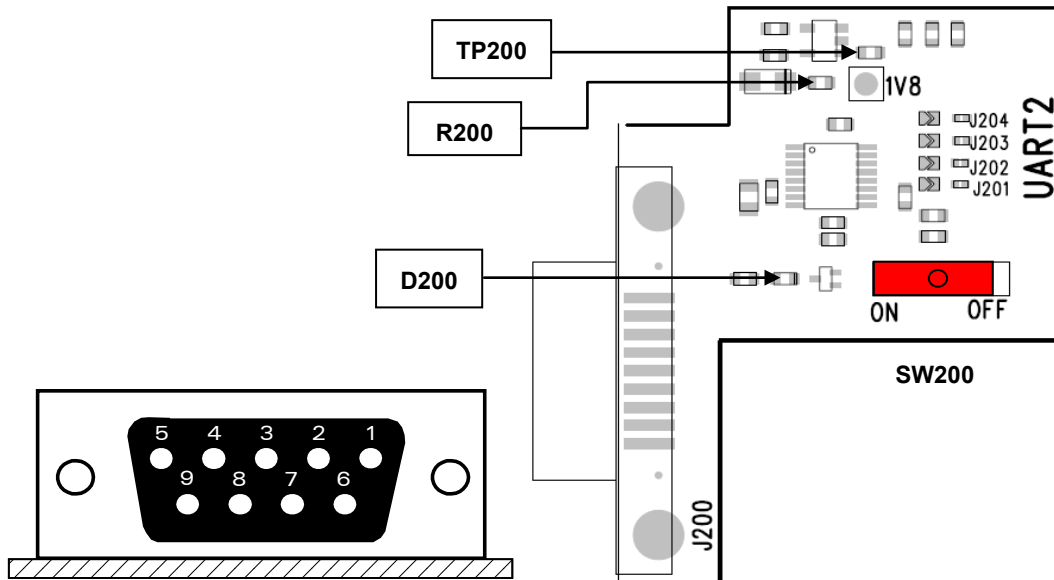

Figure 18. Enable UART2 Configuration

J200 is a SUB-D 9-pin female connector. The table below defines its connector signals.

Table 6. UART2 Connector Pin Out

Pin #	Signal Name	I/O	I/O Type	Description
1	Not used(*)	-	-	-
2	CT104 RXD	O	RS232 (V24/V28)	Receive serial data
3	CT103 TXD	I	RS232 (V24/V28)	Transmit serial data
4	Not used(*)	-	-	-
5	GND			Ground
6	Not used(*)	-	-	-
7	CT105 RTS	I	RS232 (V24/V28)	Request To Send
8	CT106 CTS	O	RS232 (V24/V28)	Clear To Send
9	Not used(*)	-	-	-

(*) Only 4 signals are used on this connector.

UART2 Configuration

The WISMO Series Development Kit acts as a DCE and is connected to a DTE (PC or terminal) with a “straight cable”. There are only 4 signals on the UART2 as shown in the figure below.

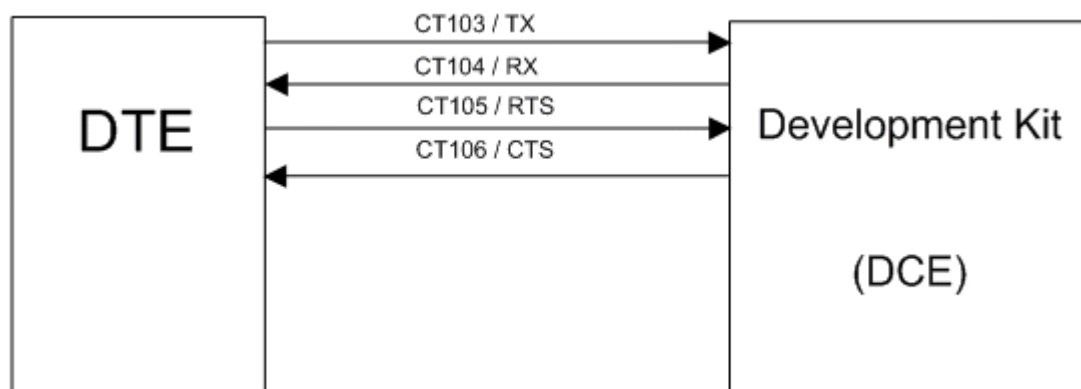

Figure 19. RS232 Auxiliary Serial Link

LED Signalization (D200)

This green LED indicates the UART2 state. The UART2 interface can be used when this LED is lit.

Enabling UART2 Function (SW200)

The UART2 interface can be enabled by switching the SW200 switch to the “ON” position. Refer to Figure 18 Enable UART2 Configuration for a visual representation.

Switch “XMODEM” (SW100)

Caution: The “XMODEM” switch must always be in the “OFF” position, as shown in the figure below. Do not use this switch. If SW100 is in the wrong position (“ON”), UART1 will not work properly.

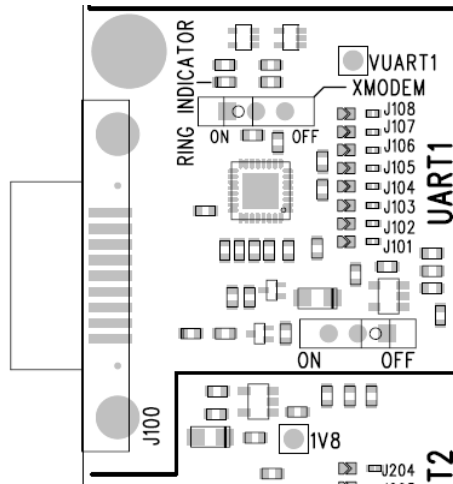

Figure 20. XMODEM Switch Configuration (SW100)

Table 7. XMODEM Configuration

Mode	XMODEM
Normal	OFF
-	-

SIM

SIM Connector (J400)

J400 is a standard 1V8 or 3V socket.

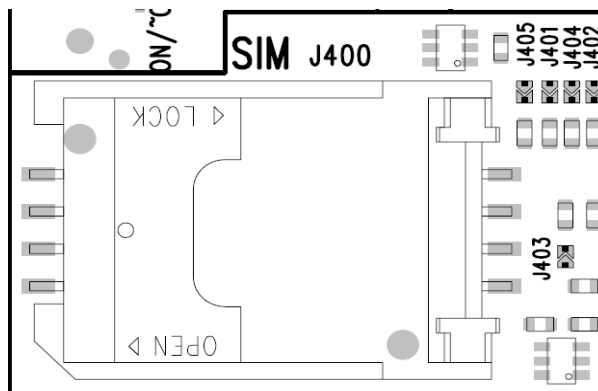

Figure 21. SIM Connector

The following table details the signals and relative pins for the SIM connector.

Table 8. SIM Connector Pin Out

Pin #	Signal Name	I/O	I/O Type	Description
1	SIM-VCC	O	1V8 or 2V9	SIM Power Supply
2	SIM-RST	O	1V8 or 2V9	SIM Reset
3	SIM-CLK	O	1V8 or 2V9	SIM Clock
4	SIMPRES	I	2V8 max(*)	SIM Card Detect (Not used)
5	GND			Ground
6	VPP	Not used		
7	SIM-IO	I/O	1V8 or 2V9	SIM Data
8	CC8		2V8	SIMPRES signal supply (Not used)

(*) For either 1V8 or 3V SIM cards.

The SIM interface controls both the 3V and 1.8V SIM cards.

ESD protections are available on all SIM signals.

The SIM interface of the WISMO218 and the WISMO228 could be electrically disconnected from the SIM card connector, J400, if the soldering pads, J401 to J405, are dissociated. That is, dissociating the four soldering pads allows for the transmission of undisturbed signals via the external connector (J1100) to an external interface board.

By default, the SIM signals are available on its dedicated connector, J400 (J401 to J405 are soldered).

Audio

There is one AUDIO interface in the WISMO218 and the WISMO228. Use J700 (AUDIO2) in the WISMO Series Development Kit to connect to this audio interface.

The audio connector could be disconnected from the WISMO218 or the WISMO228 when soldering pads, J702 to J709, are dissociated. That is, having it unsoldered allows for the transmission of undisturbed signals via the external connector (J1100) to an external interface board.

By default, AUDIO signals of the WISMO218 and the WISMO228 are available on its dedicated connector J700 (AUDIO2) when J702 to J705 are soldered.

AUDIO1 Connector (J701)

The audio function at AUDIO1 J701 is not available.

AUDIO2 Connector (J700)

The microphone signal of the WISMO218 and the WISMO228 can either be single ended or differential. By default, both microphone and speaker signals are set to be differential with the following WISMO Series Socket-Up Board and WISMO Series Development Kit configuration.

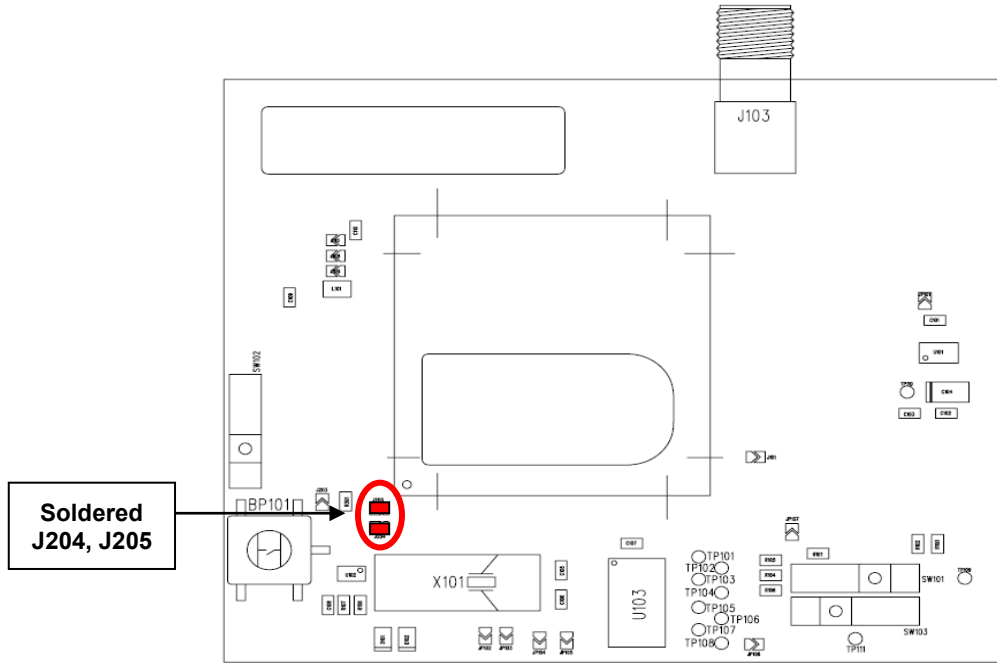
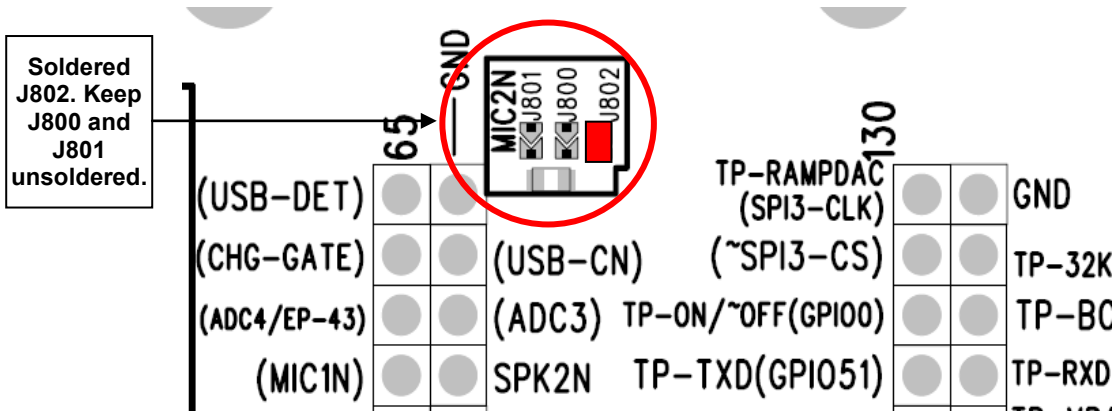

Figure 22. Settings for a Differential Microphone on the WISMO Series Socket-Up Board



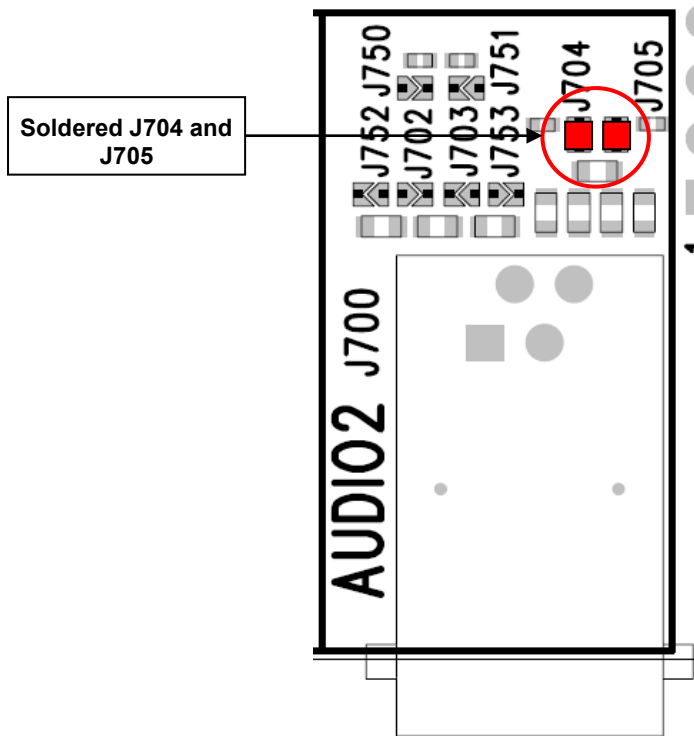

Figure 23. Settings for a Differential Microphone on the WISMO Series Development Kit

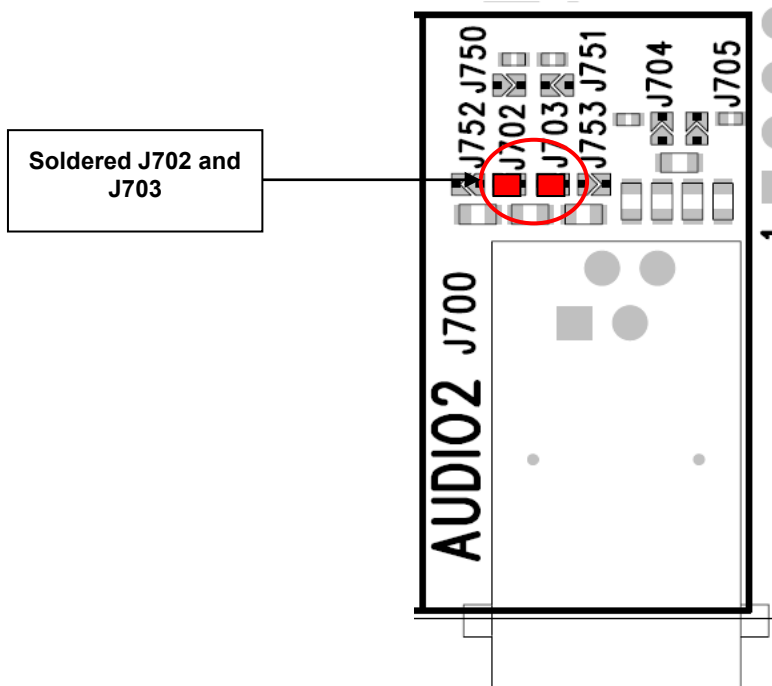

Figure 24. Settings for a Differential Speaker on the WISMO Series Development Kit

For a single-ended microphone, only the settings on the WISMO Series Socket-Up Board should be modified. Refer to the following figure.

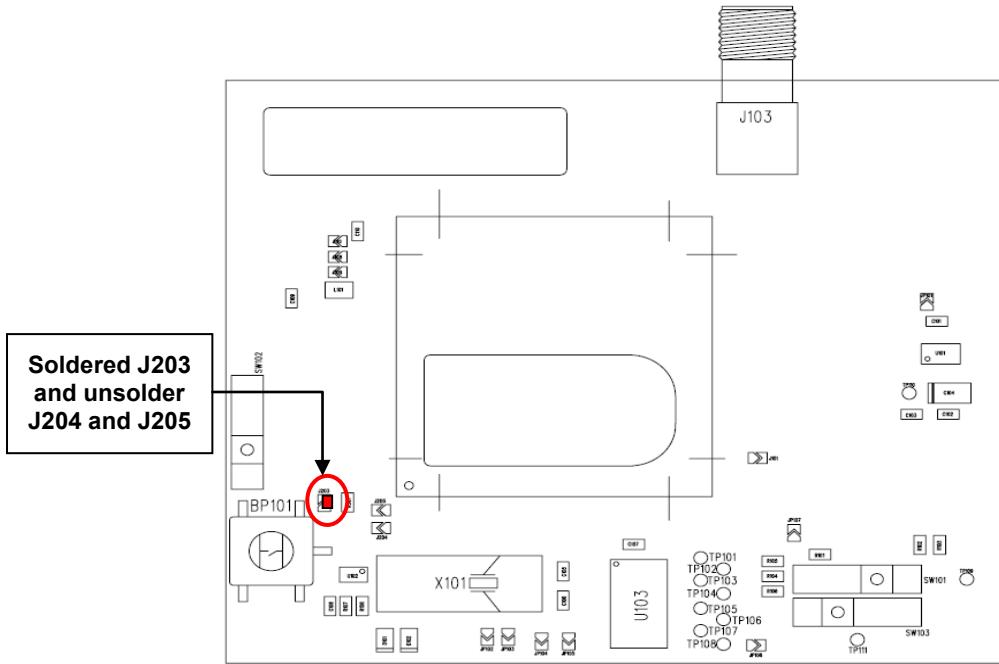

Figure 25. Settings for a Single-Ended Microphone on the WISMO Series Socket-Up Board

Note that J700 is an RJ9 4-pin connector.

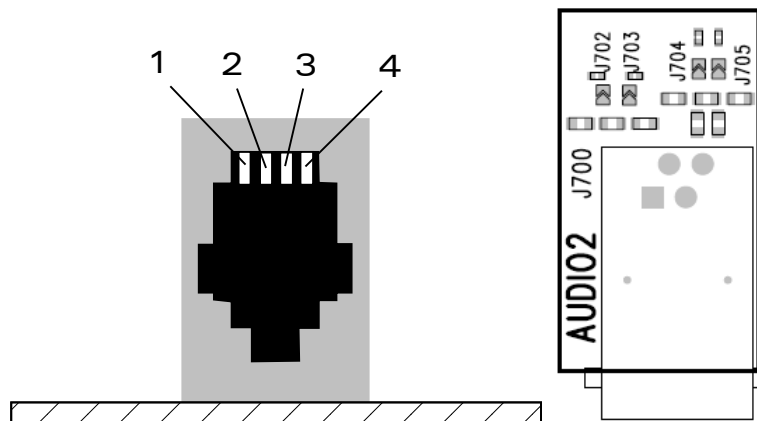

Figure 26. AUDIO2 Connector

The following table describes the signals and relative pins for the AUDIO2 connector.

Table 9. AUDIO2 Connector Pin Out

Pin #	Signal Name	I/O	I/O Type	Description
1	MIC Ground	GND	Analog	Microphone ground
2	HSET_OUTN	O	Analog	Main speaker negative output
3	HSET_OUTP	O	Analog	Main speaker positive output

Pin #	Signal Name	I/O	I/O Type	Description
4	INTMIC_P	I	Analog	Main microphone positive input

Other Interfaces

There are some other interfaces available on the WISMO Series Development Kit. These signals are available on the test points of the WISMO Series Development Kit, and also on the external board connector J1100.

Power Supply Function

VCC_2V8 is the VGPI0 output from the WISMO218 or the WISMO228. The voltage of VCC_2V8 is 2.8V. VCC_2V8 can be used to connect pull-up resistors, and it must only be used as a reference supply.

Backup Battery Function

The WISMO218 and the WISMO228 provides an input/output signal, VBAT-RTC, for connecting a Real Time Clock power supply. This pin is used as a backup power supply to preserve the date and time when VBATT is switched off (no VBATT).

ADC Function

The WISMO218 and the WISMO228 provides one analog to digital converter, AUX_ADC0. AUX_ADC0 of the WISMO218 and the WISMO228 is connected to ADC1/BAT-TEMP in the WISMO Series Development Kit.

Antenna Function

Use the SMA connector, J103, available on the WISMO Series Socket-Up Board for customer applications.

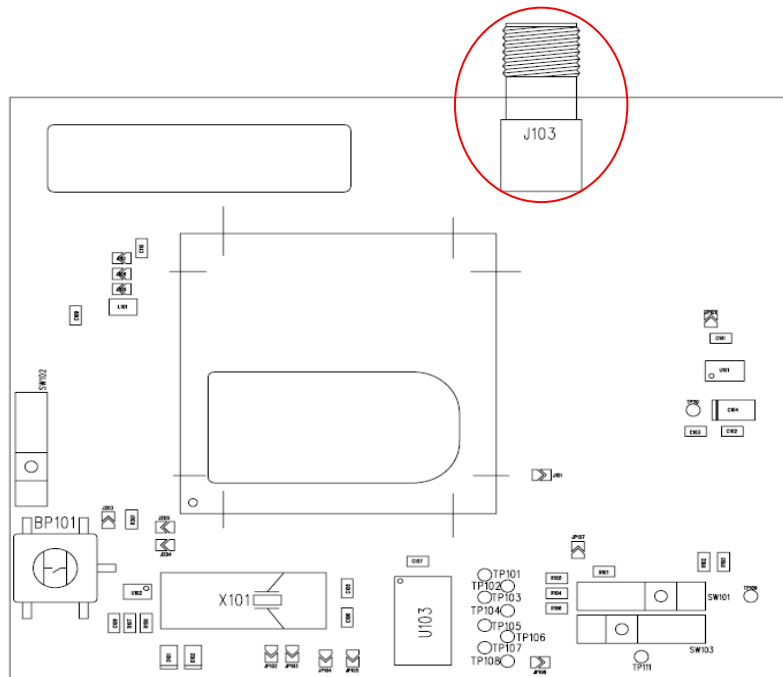

Figure 27. SMA Connector on the WISMO Series Socket-Up Board for Customer Applications

External Board Connector (J1100)

The external board connector is an interface to connect an external test bench for testing or debugging.

WISMO218 and WISMO228 Signals

Most of the WISMO Series Socket-Up Board signals are connected to the external board connector (J1100) and are available via TP from the center of the WISMO Series Development Kit. The J1100 connector pin out is listed in the table below.

For further information about the WISMO218 and the WISMO228 signals and multiplexing, please refer to the WISMO218 Product Technical Specification and Customer Design Guideline and the WISMO228 Product Technical Specification and Customer Design Guideline.

External Board Connector (J1100)

Table 10. External Board Connector (J1100) Pin Out

Pin #	Signal Name	I/O	I/O Type	Description
1	VBATT	I	Supply	Battery Input
2	VBATT	I	Supply	Battery Input
3	Not used	-	-	-
4	Not used	-	-	-

Pin #	Signal Name	I/O	I/O Type	Description
5	Not used	-	-	-
6	VCC_2V8	O	Supply	2.8V digital supply output ¹
7	GND	-	-	Ground
8	BAT-RTC	I/O	Supply	RTC back-up supply
9	SIM-VCC	O	Supply	SIM card supply
10	Not used	-	-	-
11	SIM-CLK	O	1V8 / 2V9	SIM clock
12	SIM-IO	I/O	1V8 / 2V9	SIM data
13	~SIM-RST	O	1V8 / 2V9	SIM reset
14	GND	-	-	Ground
15	BUZZER	O	2V8	PWM2 from the WISMO218 intended for controlling buzzer
16	FLASH-LED	O	2V8	Network status / Burst indication
17	ON / ~OFF	I	2V8	Power on signal from L38
18	Not used	-	-	-
19	~RESET	I	2V8	System Reset (Active Low)
20	Not used	-	-	-
21	BAT-TEMP	I	Analog	ADC0 input for battery temperature measurement
22	GND	-	-	Ground
23	SPI1-I	I/O	2V8	SPI interface MUXed with General purpose input / output
24	SPI1-CS	I/O	2V8	SPI interface MUXed with General purpose input / output
25	SPI1-IO	I/O	2V8	SPI interface MUXed with General purpose input / output
26	SPI1-CLK	I/O	2V8	SPI interface MUXed with General purpose input / output
27	Not used	-	-	-
28	Not used	-	-	-
29	Not used	-	-	-
30	Not used	-	-	-
31	GND	-	-	Ground
32	CT104-RXD2 / GPIO15	I/O	2V8	Auxiliary RS232 Receive Serial Data (According to PC view and Multiplexed)
33	~CT106-CTS2 / GPIO16	I/O	2V8	Auxiliary RS232 Clear To Send (According to PC view and Multiplexed)
34	CT103-TXD2 / GPIO14	I/O	2V8	Auxiliary RS232 Transmit Serial Data (According to PC view and Multiplexed)
35	GND	-	-	Ground
36	~CT105-RTS2 / GPIO17	I/O	2V8	Auxiliary RS232 Request To Send (According to PC view and Multiplexed)
37	Not used	-	-	-

Pin #	Signal Name	I/O	I/O Type	Description
38	Not used	-	-	-
39	Not used	-	-	-
40	GND	-	-	Ground
41	Not used	-	-	-
42	Not used	-	-	-
43	Not used	-	-	-
44	Not used	-	-	-
45	Not used	-	-	-
46	Not used	-	-	-
47	Not used	-	-	-
48	Not used	-	-	-
49	Not used	-	-	-
50	Not used	-	-	-
51	GND	-	-	Ground
52	GND	-	-	Ground
53	MIC2P	I	Analog	Microphone 2 positive input
54	Not used	-	-	-
55	Not used	-	-	-
56	Not used	-	-	-
57	Not used	-	-	-
58	SPK2P	O	Analog	Speaker 2 positive output
59	Not used	-	-	-
60	SPK2N	O	Analog	Speaker 2 negative output
61	Not used	-	-	-
62	Not used	-	-	-
63	Not used	-	-	-
64	Not used	-	-	-
65	Not used	-	-	-
66	VBATT	I	Supply	Battery Input
67	VBATT	I	Supply	Battery Input
68	CT103-TXD1 / GPIO36	I/O	2V8	Main RS232 Transmit Serial Data (According to PC view and Multiplexed)
69	~CT125-RI1 / GPIO42	I/O	2V8	Main RS232 Ring indicator (According to PC view and Multiplexed) MUXed with KEYOUT3
70	~CT106-CTS1 / GPIO39	I/O	2V8	Main RS232 Clear To Send (According to PC view and Multiplexed)
71	CT104-RXD1 / GPIO37	I/O	2V8	Main RS232 Receive Serial Data (According to PC view and Multiplexed)
72	~CT105-RTS1 / GPIO38	I/O	2V8	Main RS232 Request To Send (According to PC view and Multiplexed)
73	~CT109-DCD1 / GPIO43	I/O	2V8	Main RS232 Data Carrier Detect (According to PC view and Multiplexed) MUXed with KEYOUT1

Pin #	Signal Name	I/O	I/O Type	Description
74	~CT108-2-DTR1 / GPIO41	I/O	2V8	Main RS232 Data Terminal Ready (According to PC view and Multiplexed)
75	~CT107-DSR1 / GPIO40	I/O	2V8	Main RS232 Data Set Ready (According to PC view and Multiplexed) MUXed with KEYOUT2
76	GND	-	-	Ground
77	GND	-	-	Ground
78	Not used	-	-	-
79	Not used	-	-	-
80	Not used	-	-	-
81	Not used	-	-	-
82	Not used	-	-	-
83	Not used	-	-	-
84	Not used	-	-	-
85	Not used	-	-	-
86	Not used	-	-	-
87	Not used	-	-	-
88	Not used	-	-	-
89	Not used	-	-	-
90	Not used	-	-	-
91	Not used	-	-	-
92	Not used	-	-	-
93	Not used	-	-	-
94	Not used	-	-	-
95	Not used	-	-	-
96	Not used	-	-	-
97	Not used	-	-	-
98	GND	-	-	Ground
99	GND	-	-	Ground
100	Not used	-	-	-
101	Not used	-	-	-
102	GND	-	-	Ground
103	GND	-	-	Ground
104	Not used	-	-	-
105	Not used	-	-	-
106	Not used	-	-	-
107	Not used	-	-	-
108	PWM0(GPIO3)	I/O	2V8	PWM0 signal from L38
109	GND	-	-	Ground
110	Not used	-	-	-
111	GPIO2(GPIO20)	I/O	2V8	General purpose input / output
112	SPI-IRQ(GPIO23)	I/O	2V8	General purpose input / output MUXed with SPI interrupt
113	GPIO5(GPIO22)	I/O	2V8	General purpose input / output MUXed with KEYIO1

Pin #	Signal Name	I/O	I/O Type	Description
114	Not used	-	-	-
115	Not used	-	-	-
116	GPIO3(GPIO21)	I/O	2V8	General purpose input / output
117	PWM1 (INT1/GPIO25)	O	2V8	PWM1 signal from WISMO218
118	Not used	-	-	-
119	GPIO1(GPIO19)	I/O	2V8	General purpose input / output
120	Not used	-	-	-
121	Not used	-	-	-
122	Not used	-	-	-
123	Not used	-	-	-
124	Not used	-	-	-
125	Not used	-	-	-
126	Not used	-	-	-
127	Not used	-	-	-
128	Not used	-	-	-
129	Not used	-	-	-
130	Not used	-	-	-

1: This signal can be electrically disabled by not soldering the jumper soldering pads, J1002 and J1003.

>> | 6. ESD Protections

External ESD protections are available on the WISMO Series Development Kit for the following signals:

- SIM interface signals: SIM-VCC, SIM-IO, SIM-CLK, and SIM-RST

Other interface signals protected on the WISMO218 are as follows:

- UART1 signals with the ADM3307 transceiver
- UART2 signals with the LTC2804 transceiver

Caution: *As the test points at the center of the WISMO Series Development Kit are not protected against ESD discharge and they are directly connected to the signal pins of the WISMO218 or the WISMO228, users must be careful when using these TP signals.*

>> 7. Current Consumption Measurement

To measure the current consumption of the WISMO218 or the WISMO228, configure the WISMO Series Development Kit as shown in Figure 28 Configuration of VBATT for Current Consumption Measurement and Figure 29 Configuration of the WISMO Series Socket-Up Board for Current Consumption Measurement.

Caution: Before making any of the adjustments below, ensure that the WISMO Series Development Kit is disconnected from the power supply.

Around the Power Supply area:

- Unsolder jumper, J605 to disconnect VBATT and VBAT

Around the UART2 area:

- Disconnect UART2 from WISMO218 or the WISMO228 in the WISMO Series Socket-Up Board by dissociating J201 to J204.

Around BAT-TEMP (VBATT area):

- Remove R600, D603 and D604 in order to eliminate the current drawn by the application circuit on the WISMO Series Development Kit.
- Dissociate J605 in order to separate the power supplies of the WISMO Series Development Kit and the WISMO218 or the WISMO228.
- Connect a 4V external power supply to the test point TP602 (“VBAT”) and ground.

Note: The current from J600 is supplied to the WISMO218 or the WISMO228; while the current from TP602 is supplied to the development kit

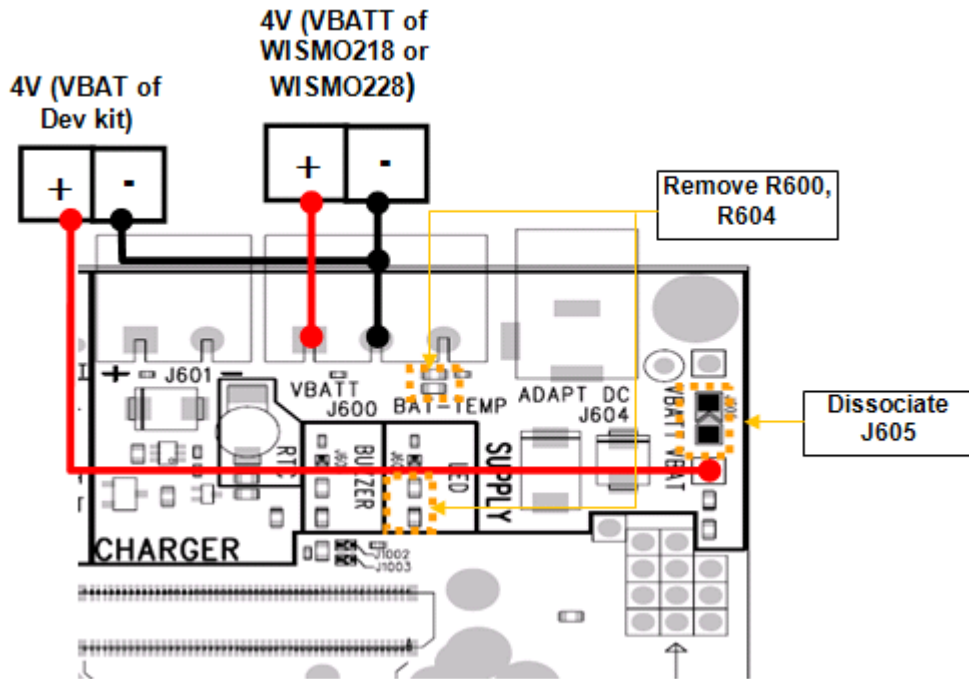

Figure 28. Configuration of VBATT for Current Consumption Measurement

Around the WISMO Series Socket-Up Board:

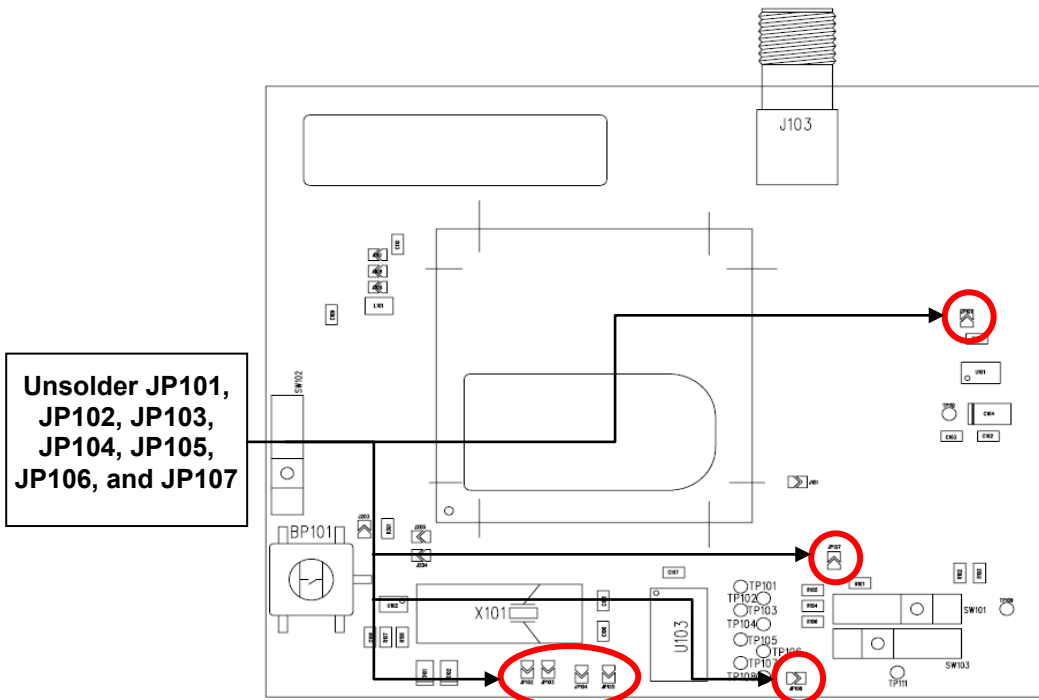

Figure 29. Configuration of the WISMO Series Socket-Up Board for Current Consumption Measurement

With this configuration, the consumption current from VBATT is ONLY* that of the WISMO218 or the WISMO228 plugged in. For further information, refer to the WISMO218 Product Technical Specification and Customer Design Guideline and the WISMO228 Product Technical Specification and Customer Design Guideline.

* Subtract a quiescent current of 50 μ A from T100.

Please note the following:

- T100 used for UART1 enable will affect power consumption on 4V (VBATT) by an additional 50 μ A.
- C600 and D604 connected on 4V (VBATT) may affect power consumption on 4V (VBATT). Disconnect these 2 components if necessary.
- Flash LED (D602) can affect power consumption and can be disconnected by opening jumper J602.

8. SPI Interface for Debugging (Spytracer Tool)

Spytracer is a PC tool that is used for debugging purposes and anomalies detection. It retrieves messages from the WISMO218 and the WISMO228, decodes these messages and then displays them for the user. It also traces messages exchanged by the different processes inside the WISMO218 or the WISMO228, which includes messages coming from the network infrastructures and specific messages from the WISMO218 or the WISMO228. An SPI-to-serial interface provides a link to connect the WISMO218 or the WISMO228 to a PC for Spytracer when using the WISMO Series Development Kit as a debug tool. (Please also refer to the section discussing UART2 for more information on the connection between a PC and the WISMO Series Development Kit.)

The following figures and procedures describe how to connect a customer product to the WISMO Series Development Kit and use it as a debug tool.

1. Prepare the WISMO Series socket-up board.

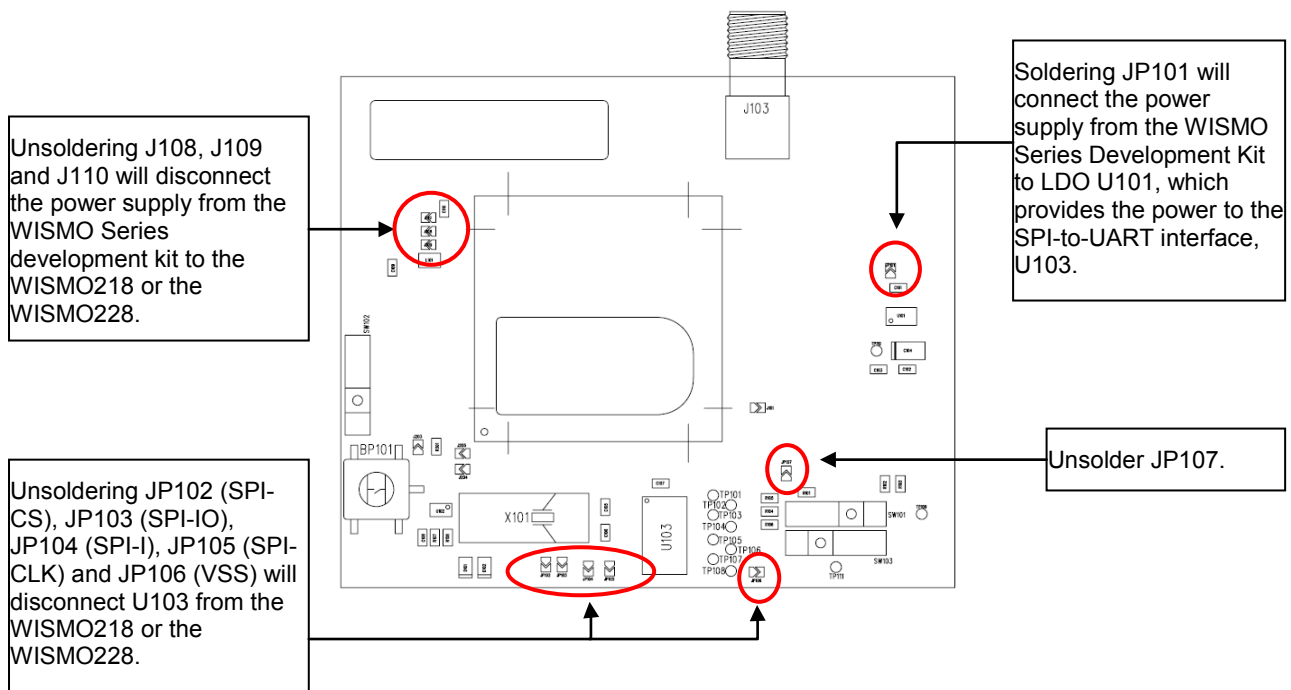

Figure 30. WISMO Series Socket-Up Board Settings for an Internal SPI Application

2. Connect the customer application and the WISMO Series socket-up board.

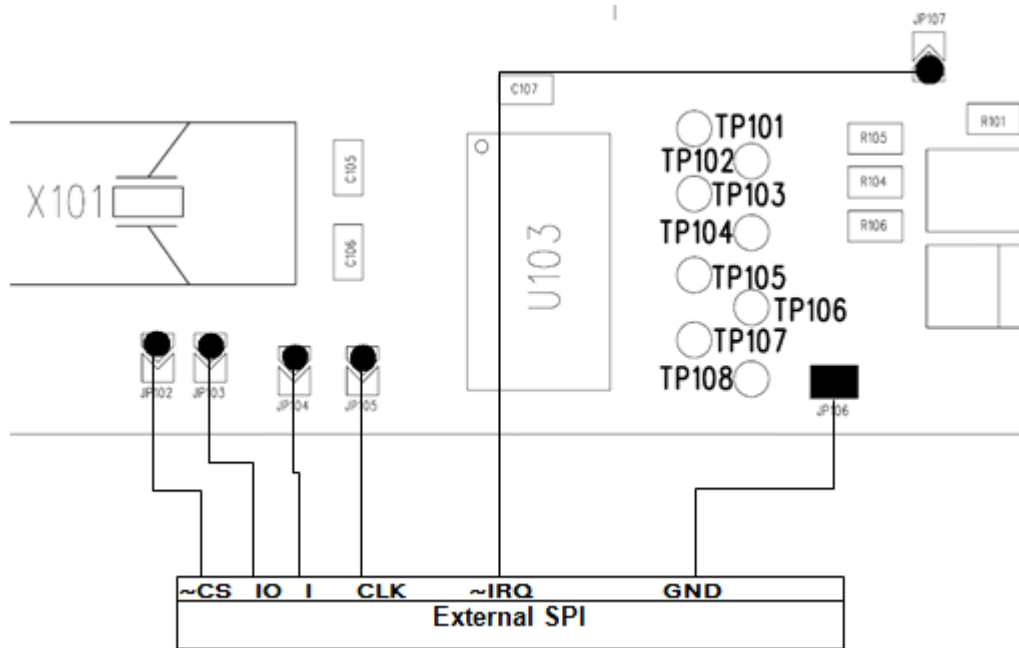
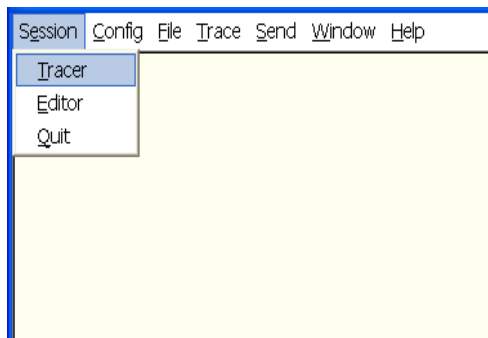
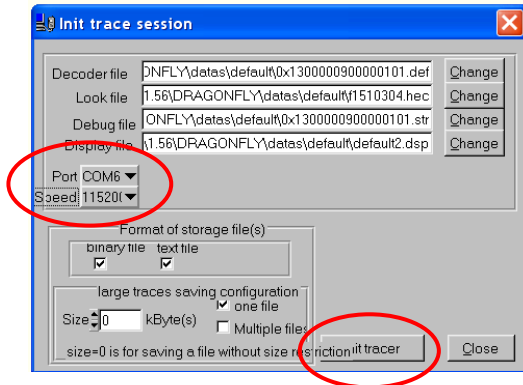

Figure 31. SPI Connection to an External Application

3. Use Spytracer to debug the WISMO218 or the WISMO228. (Please refer to the WISMO Spy Trace User Guide for additional details about Spytracer.)
 - a. Start "Spytracer".
 - b. Select "Session" → "Tracer".



- c. Select the Port and Speed, and Save. (In this example, COM6 and 115200 are selected respectively.)



- d. Accept the default values for all other settings.
- e. Switch ON the WISMO Series Development Kit.
- f. The software screen will refresh and scroll automatically as shown in the following figure if all connections and settings were properly configured.

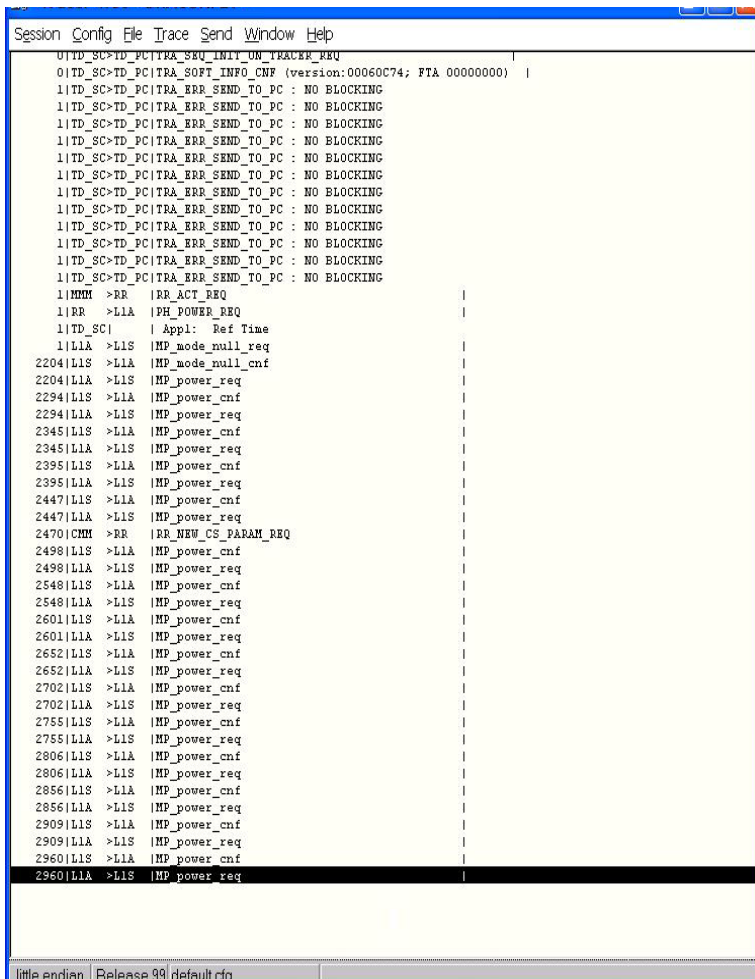

9. Installing the WISMO218 or the WISMO228 on the WMPXXX Development Kit

Note: This section is for users who have the WMPXXX Development Kit.

Both the WISMO218 and the WISMO228 can be readily used on either V20 or V21 version of the WMPXXX Development Kit, together with a WISMO Series Socket-Up Board.

Setup the WMPXXX Development Kit and the WISMO Series Socket-Up Board as follows:

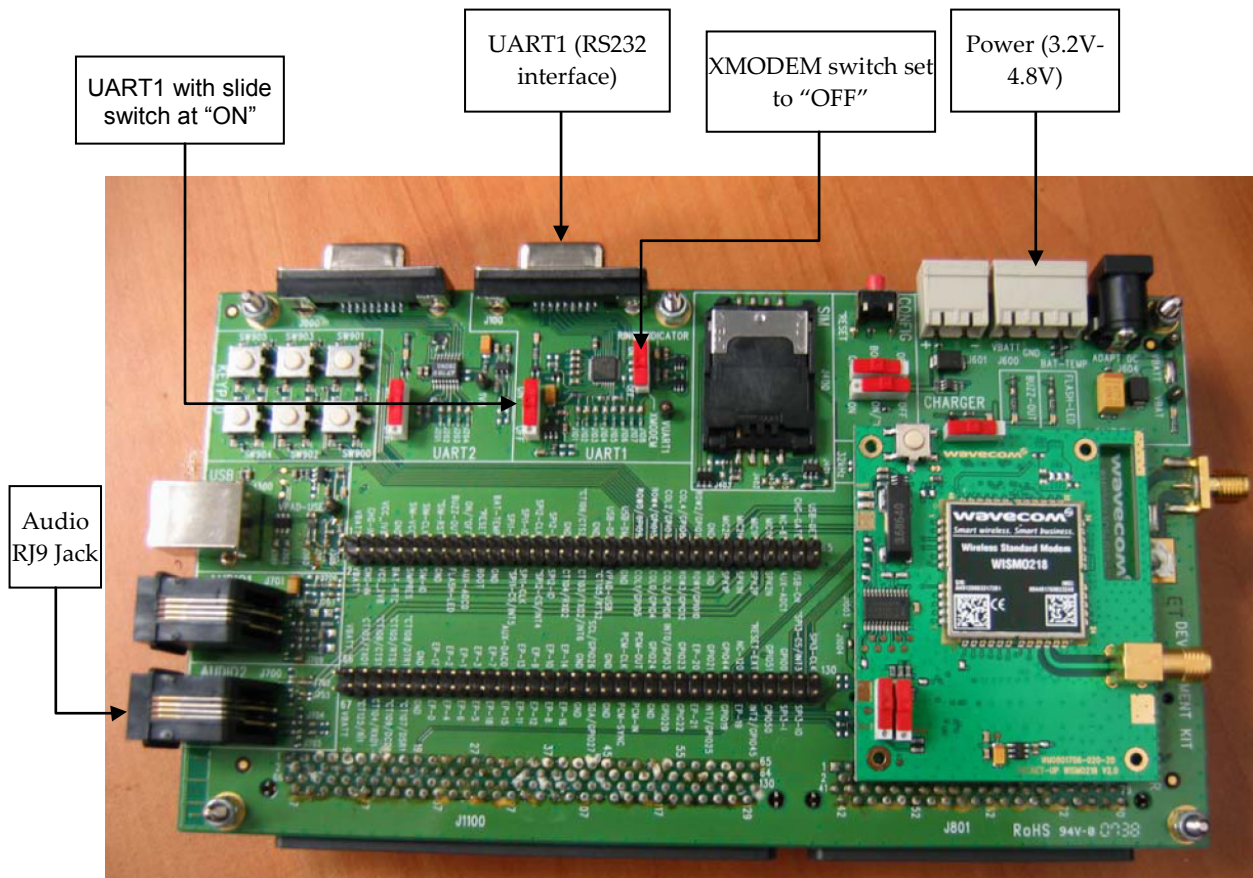

Figure 32. WMPXXX Development Kit and WISMO Series Socket-Up Board Set-Up

Caution: The ON~OFF slide switch on the WMPXXX development kit **MUST** be set to the “OFF” position, otherwise, it will short circuit the power supply when powering ON the WISMO218 or the WISMO228 using the tact switch, BP101 or the slide switch, SW102.

This slide switch on the WMPXXX development kit **MUST** be set to the "OFF" position, otherwise, it will short circuit the power supply when powering ON the WISMO218 or the WISMO228.

WMPXXX Development Kit

Not used



ON/~OFF control tact switch

ON/~OFF control Slide switch. If set to the:

- Left: Auto Power ON
- Right: Must press the tact switch to power ON

WISMO218 module or WISMO228 module

SMA connector on the WISMO Series Socket-Up board

WISMO Series Socket-Up Board

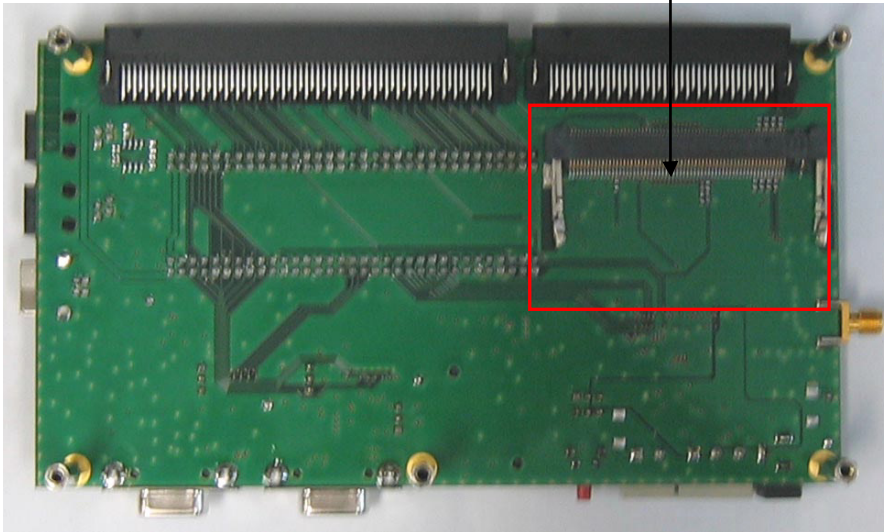

Remove the memory card from the WMPXXX development kit

10. Reference Documents

WISMO218 Product Technical Specification and Customer Design Guideline

Reference: WA_DEV_W218_PTS_002

WISMO228 Product Technical Specification and Customer Design Guideline

Reference: WA_DEV_W228_PTS_002

WISMO218 AT Commands Manual

Reference: WA_DEV_W218_UGD_003

WMP100 Wireless Microprocessor® Development Kit User Guide

Reference: WM_DEV_WUP_UGD_001

WISMO Spy Trace User Guide

Reference: WA_DEV_WISMO_UGD_006

>> 11. List of Abbreviations

Abbreviation	Definition
ADC	Analog to Digital Converter
AUX	AUXiliary
CLK	CLock
CPU	Central Process Unit
CTS	Clear To Send
DAC	Digital to Analog Converter
DC	Direct Current
DCD	Data Carrier Detect
DCE	Data Communication Equipment
DSR	Data Set Ready
DTE	Data Terminal Equipment
DTR	Data Terminal Ready
ESD	ElectroStatic Discharges
GND	GrouND
GPI	General Purpose Input
GPIO	General Purpose Input Output
GPO	General Purpose Output
IIC (I2C)	Inter IC Control bus
I/O	Input / Output
MIC	MICrophone
PC	Personal Computer
PCB	Printed Circuit Board.
PCM	Pulse Code Modulation
PWM	Pulse Width Modulation
RF	Radio Frequency
RI	Ring Indicator
RTC	Real Time Clock
RTS	Request To Send
RXD	Receive Data
SIM	Subscriber Identity Module
SPI	Serial Peripheral Interface
SPK	SPeaKer
TP	Test Point
TXD	Transmit Data
UART	Universal Asynchronous Receiver-Transmitter
USB	Universal Serial Bus

12. Appendix

This section contains schematic diagrams and data sheets of the WISMO Series Development Kit and the WISMO Series Socket-Up Board.

WISMO Series Development Kit

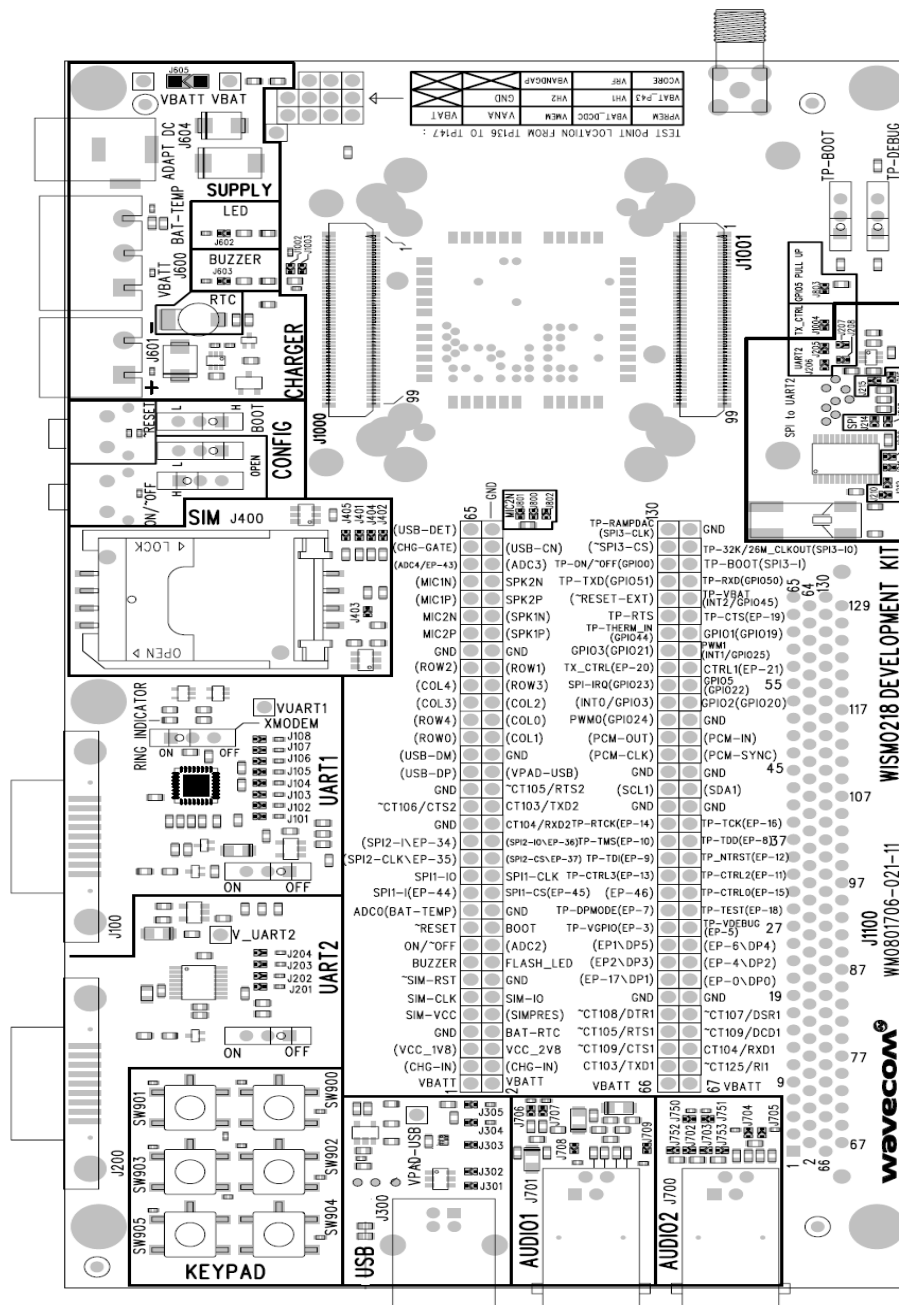

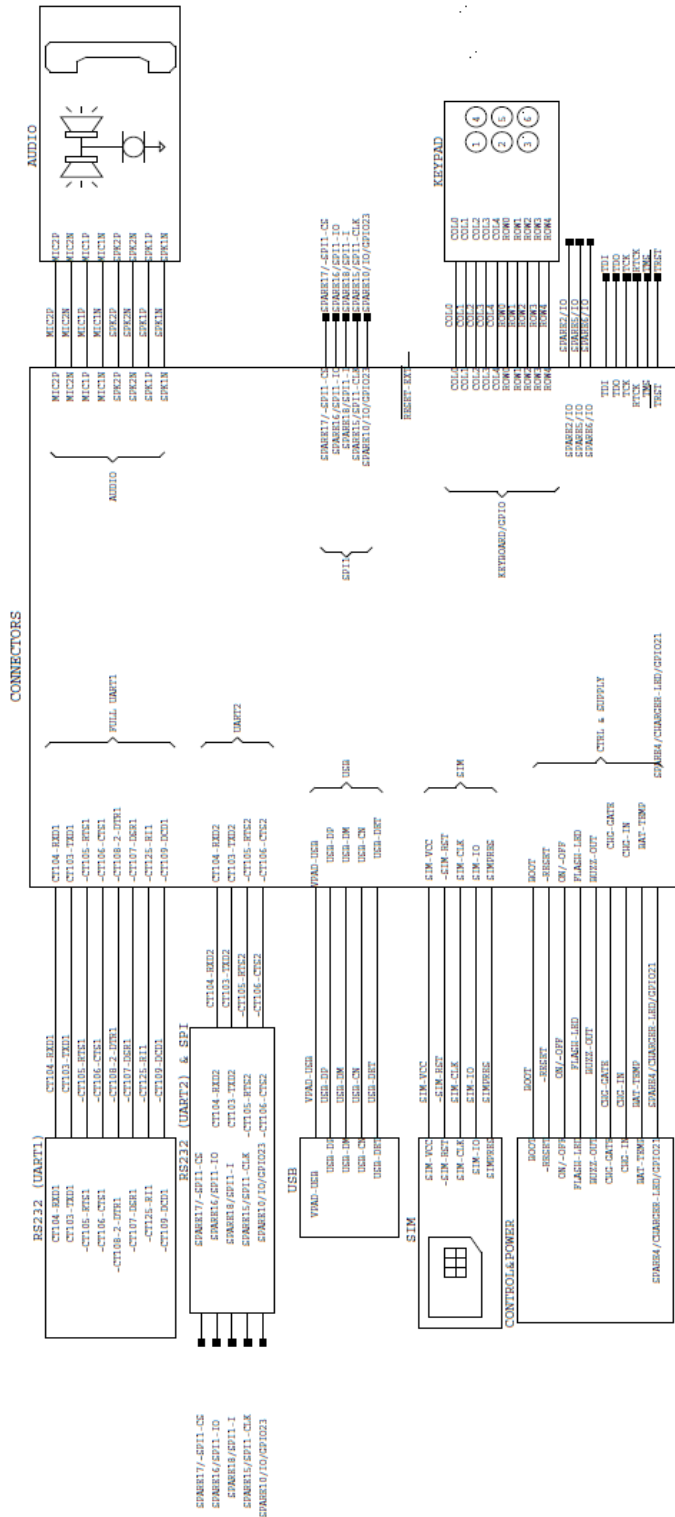

wavecom™

PROJECT: DEVELOPMENT KIT WIS0018

SCHEMATIC: HIERARCHIC

Date:	03/04/2009
Version:	1.1
Sheet:	0/11

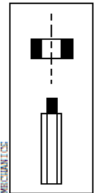

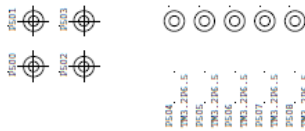
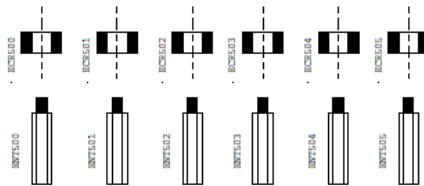
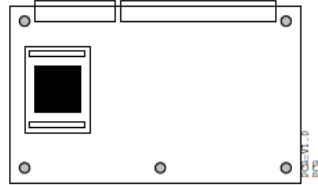

wavecom ®		PROJECT: DEVELOPMENT KIT WISMO118	
		SCHEMATIC: MECHANICAL	
Date:	03/06/2009	Revision:	1.1
Created By:		Checked:	5/11
WFO			

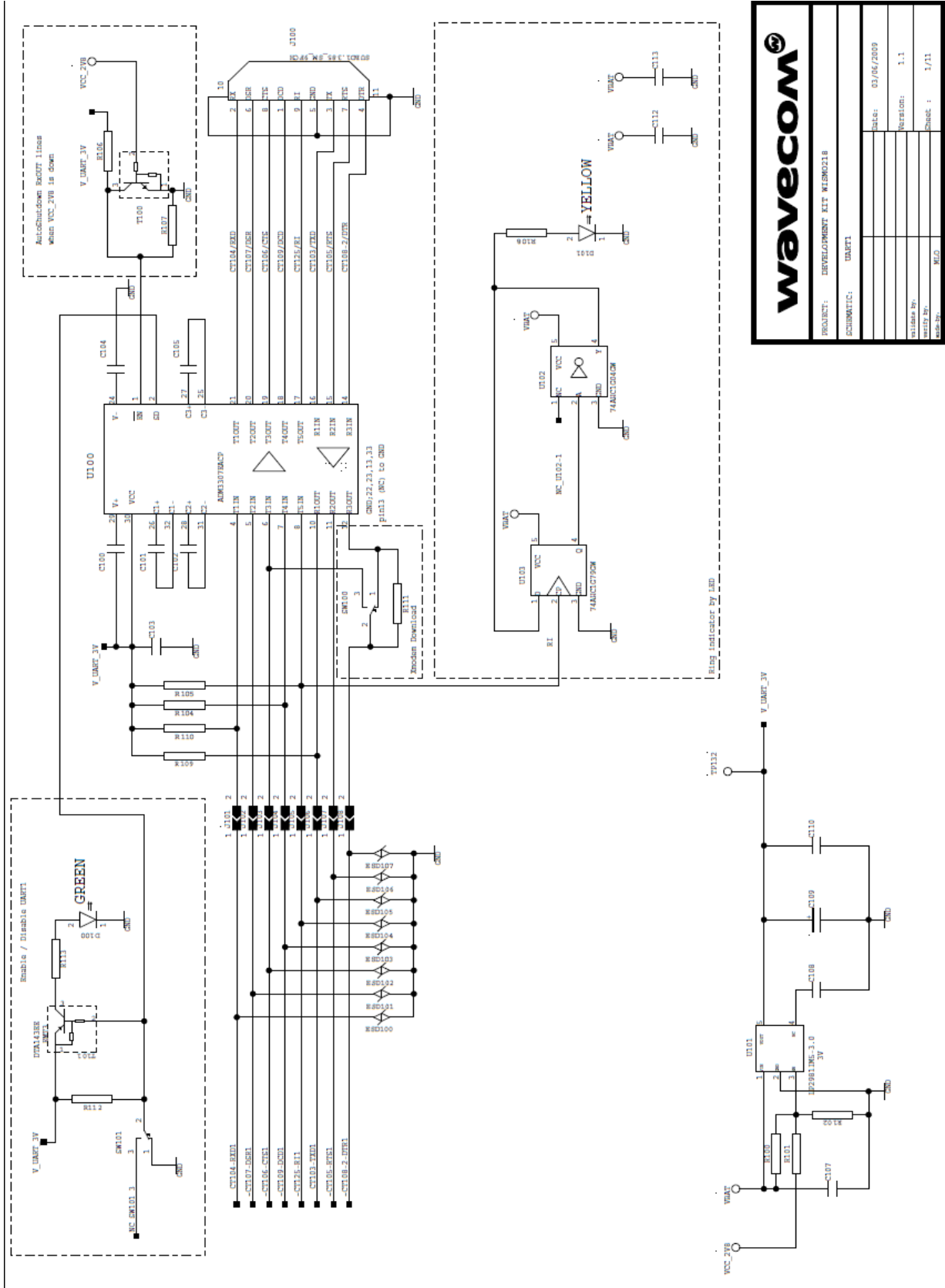

wavecom

PROJECT: DEVELOPMENT KIT WISMO218
SCHEMATIC: UMFT1

Date:	03/06/2009
Revision:	1.1
Created By:	WLD
Checked By:	1/11

wavecom®

PROJECT: DEVELOPMENT KIT WISMO218

SCHEMATIC: SIM

Date:	03/06/2009
Version:	1.1
Created By:	
Mod By:	
Mod Date:	4/11

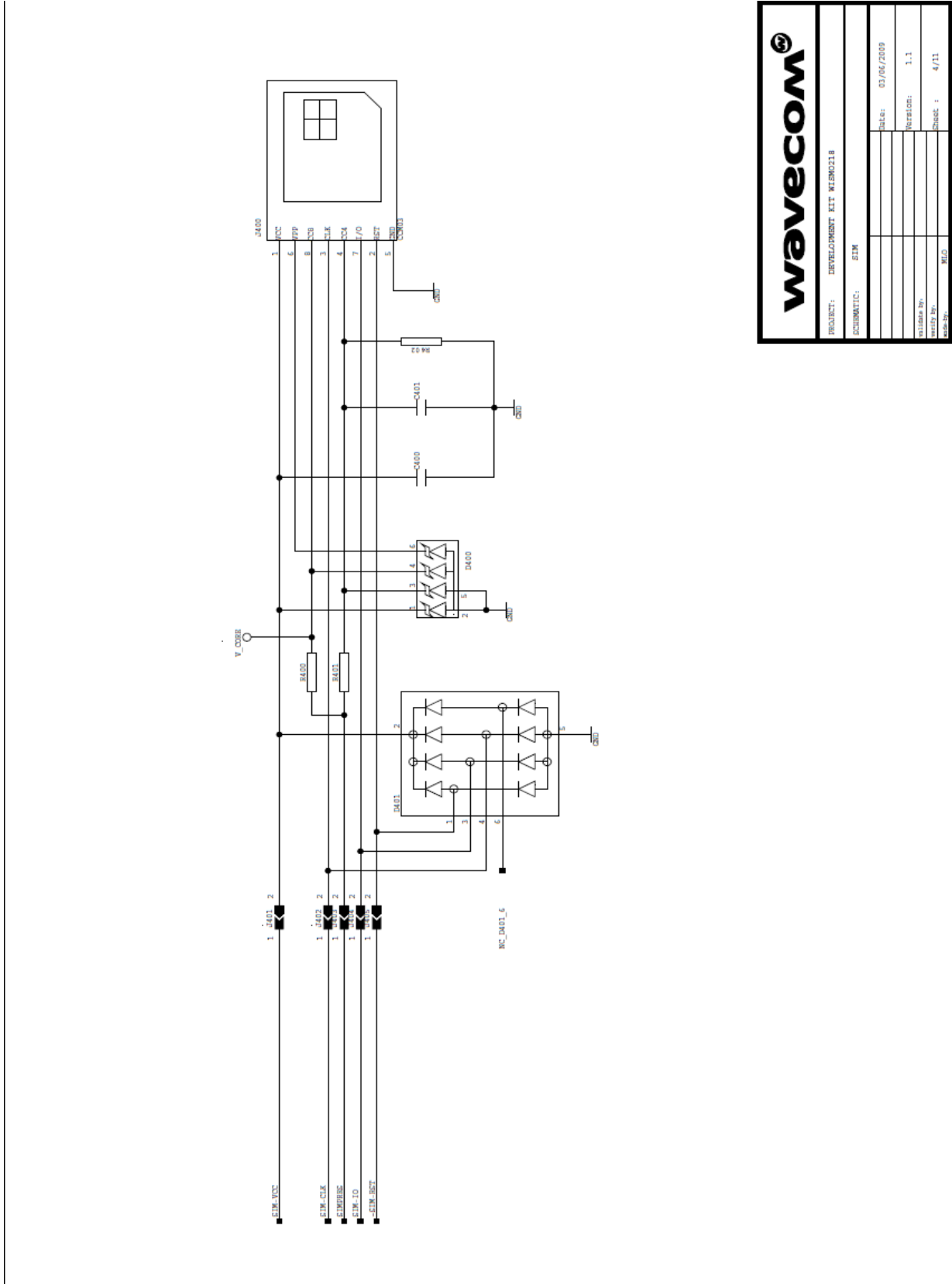

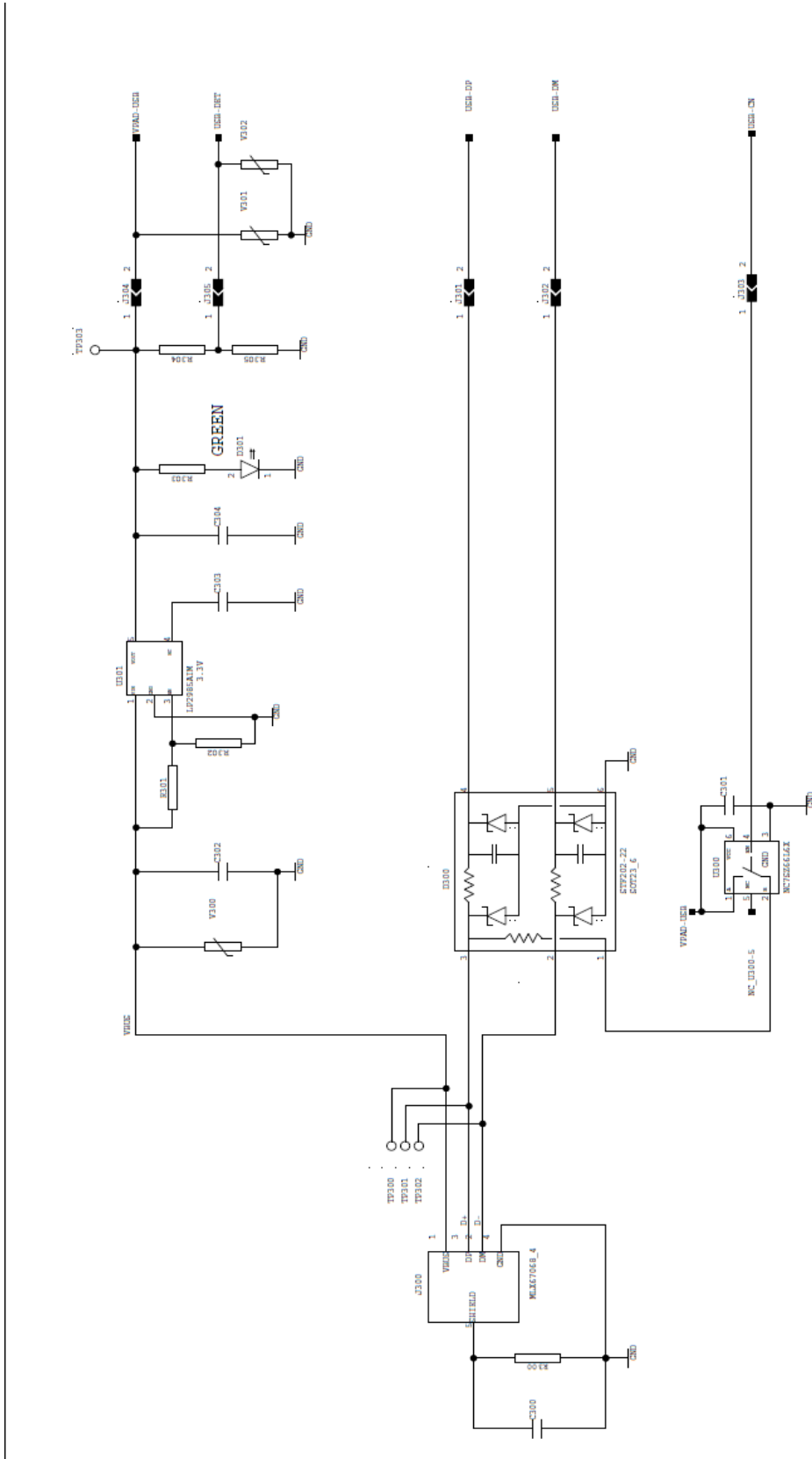

wavecom

PROJECT: DEVELOPMENT KIT WISMO218
SCHEMATIC: USB

Date:	03/06/2009
Version:	1.1
Author:	
Checked:	
Drawn:	
Scale:	
Sheet:	3/11

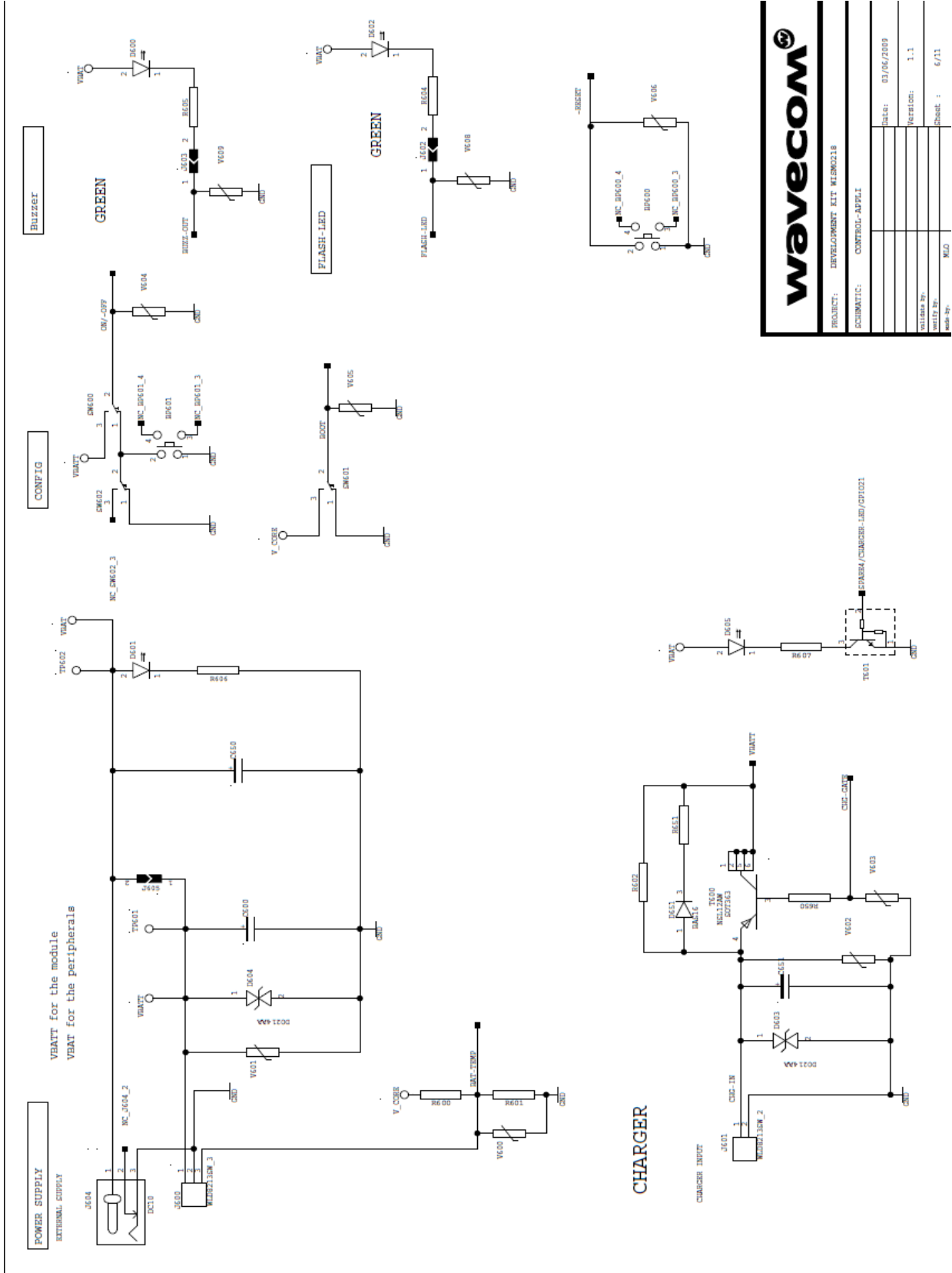

wavecom

PRODUCT: DEVELOPMENT KIT WISMO218
 SCHEMATIC: CONTROL-APP11
 Date: 01/06/2009
 Version: 1.1
 Drawn By: MLO
 Sheet: 6/11

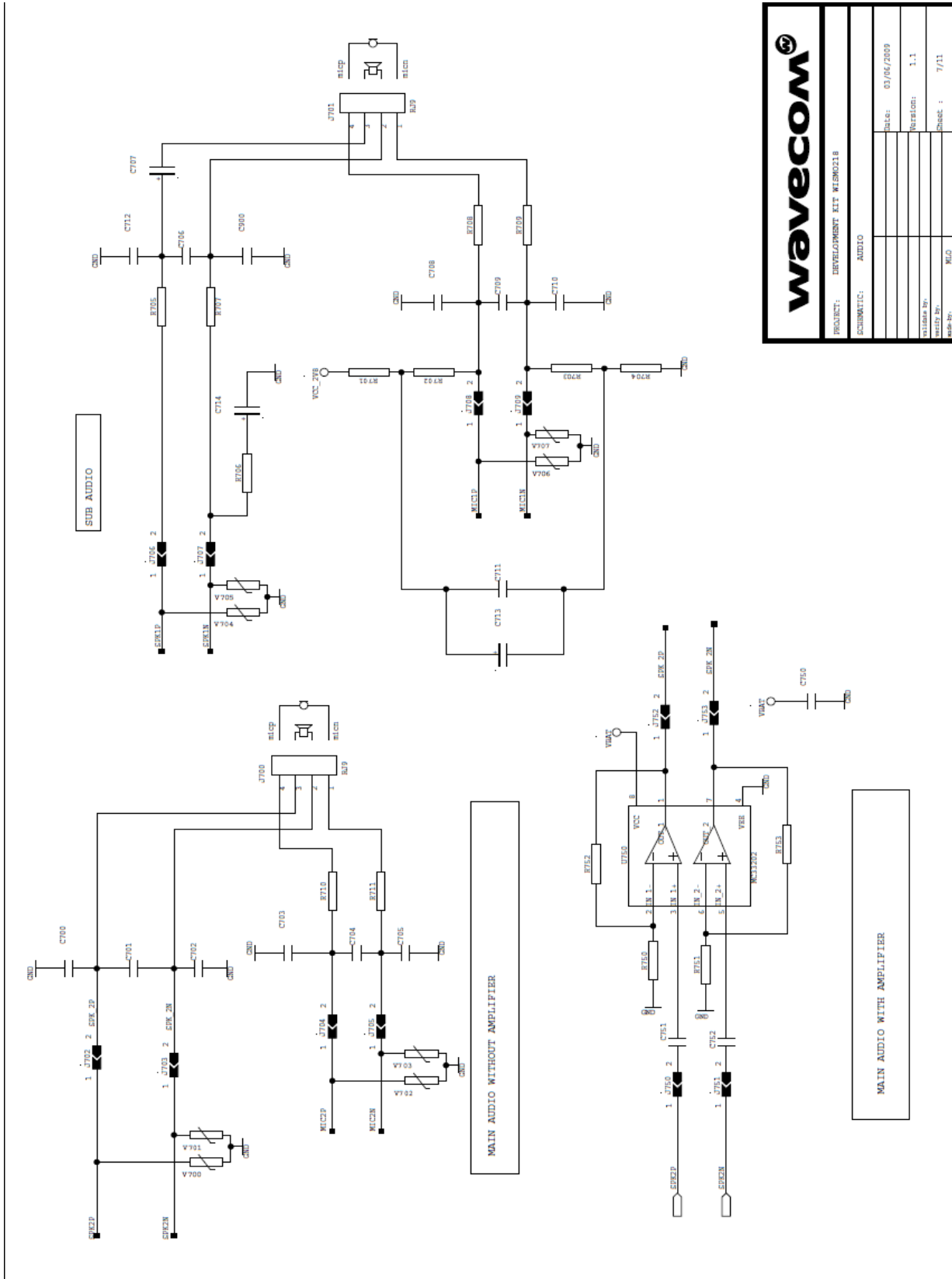

wavocom

PROJECT: DEVELOPMENT KIT WISMO218
SCHEMATIC: AUDIO

Date:	03/04/2009
Version:	1.1
SIEMENS No.:	
WAVECOM No.:	
Drawn By:	MJO
Checked:	7/11

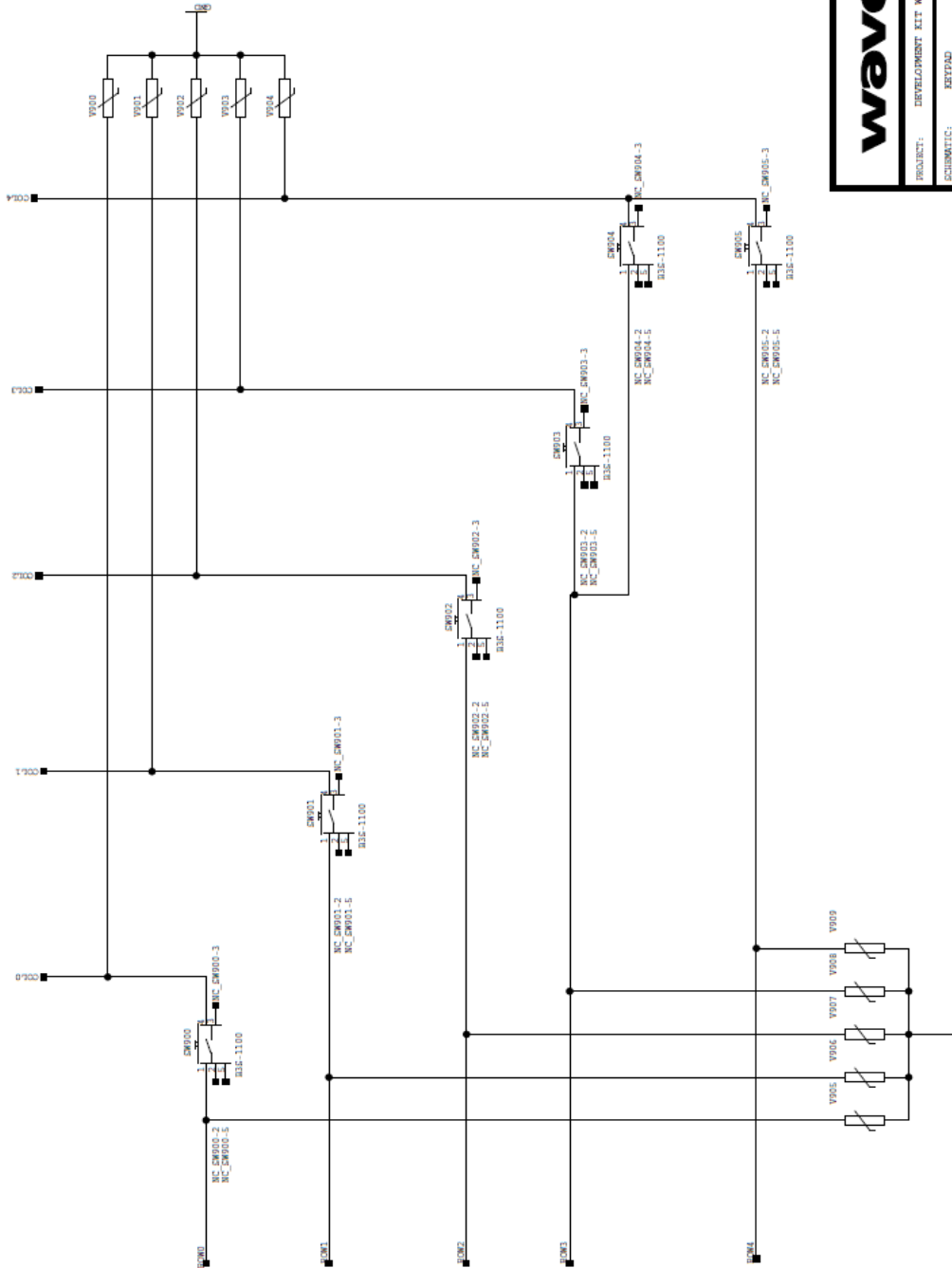

wavecom

PROJECT: DEVELOPMENT KIT WISMO318
 SCHEMATIC: REV1A0

Date:	03/04/2009
Version:	1.1
Created By:	
Rev-By:	
Sheet:	9/11

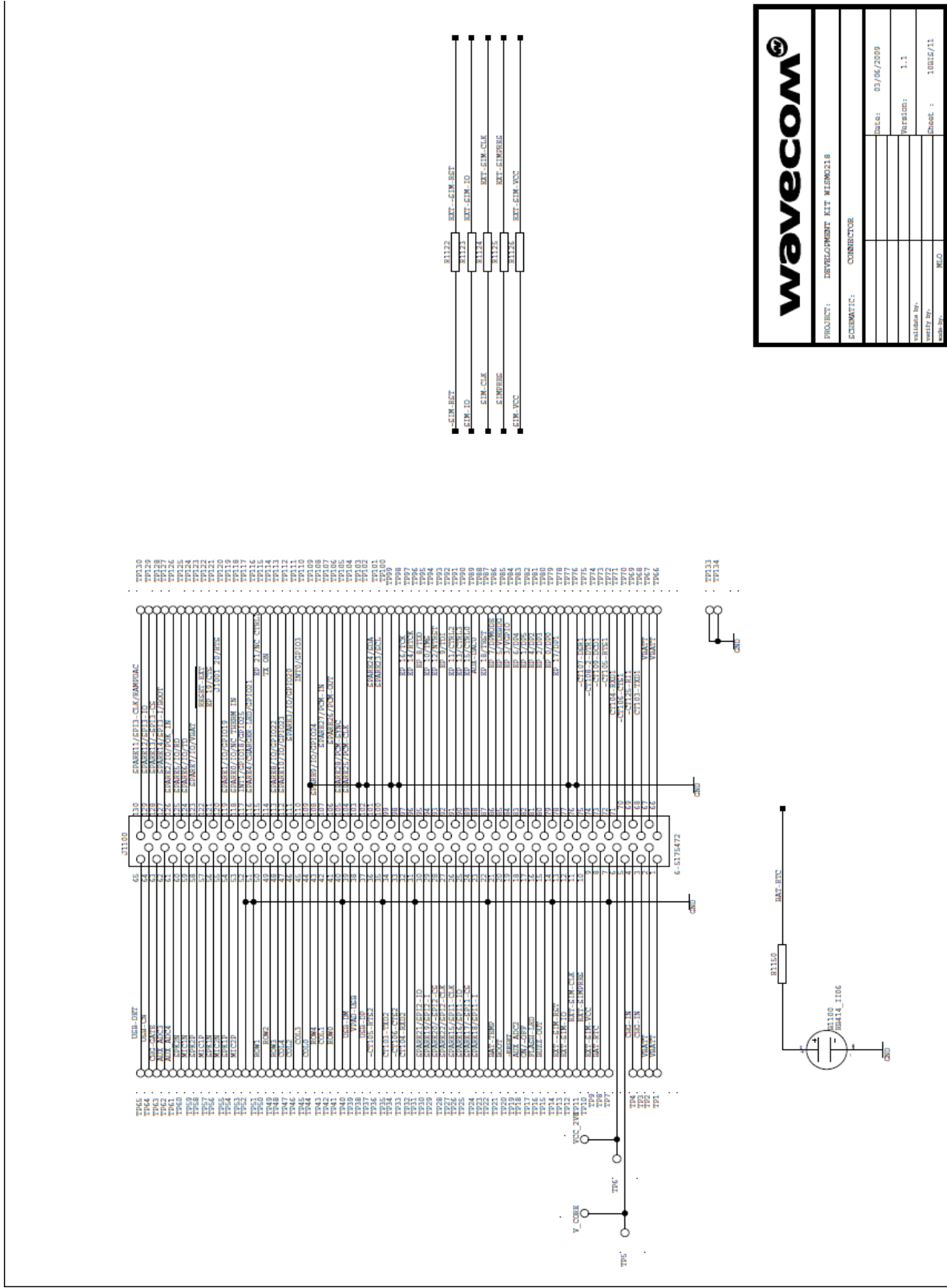

wavecom

PROJECT: DEVELOPMENT KIT WISMO218

SCHEMATIC: CONNECTOR

DATE: 03/06/2009

REVISION: 1.1

Sheet : 106E/71

wavecom

PROJECT: DEVELOPMENT KIT WISMO218

SCHEMATIC: TEST SOCKET

DATE:	03/06/2009
REVISION:	1.1
DATE:	
REVISION:	
DATE:	
REVISION:	

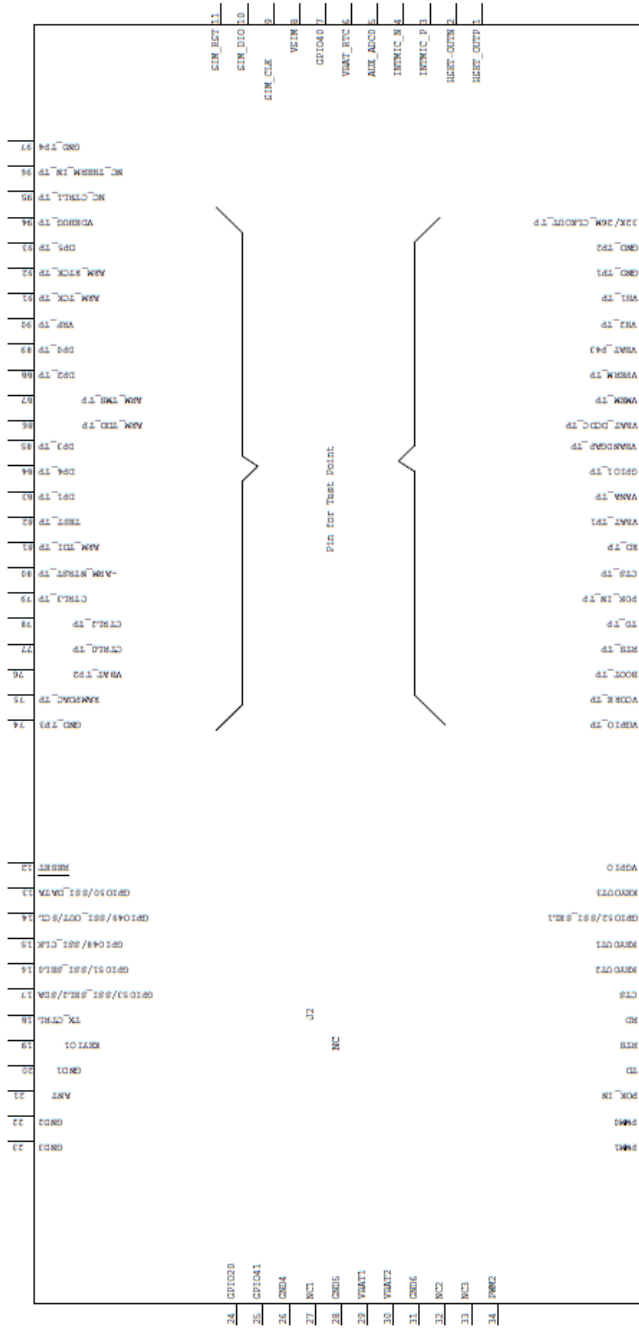

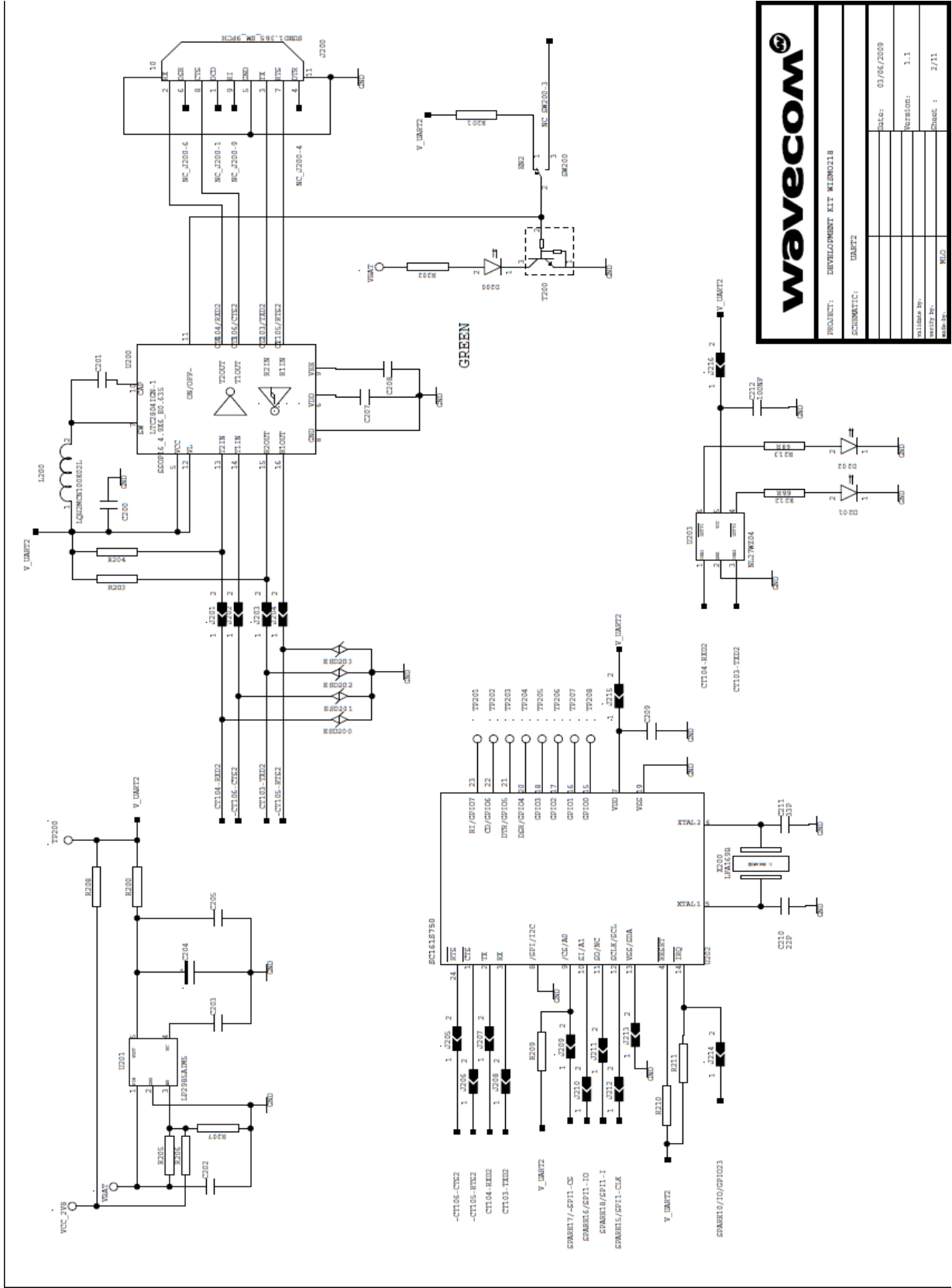

wavecom

PROJECT: DEVELOPMENT KIT WISMO218
SCHEMATIC: UMPT2

Date: 03/06/2009
Revision: 1.1
Created By: [Name]
Checked By: [Name]
Date: 2/11

WISMO Series Socket-Up Board

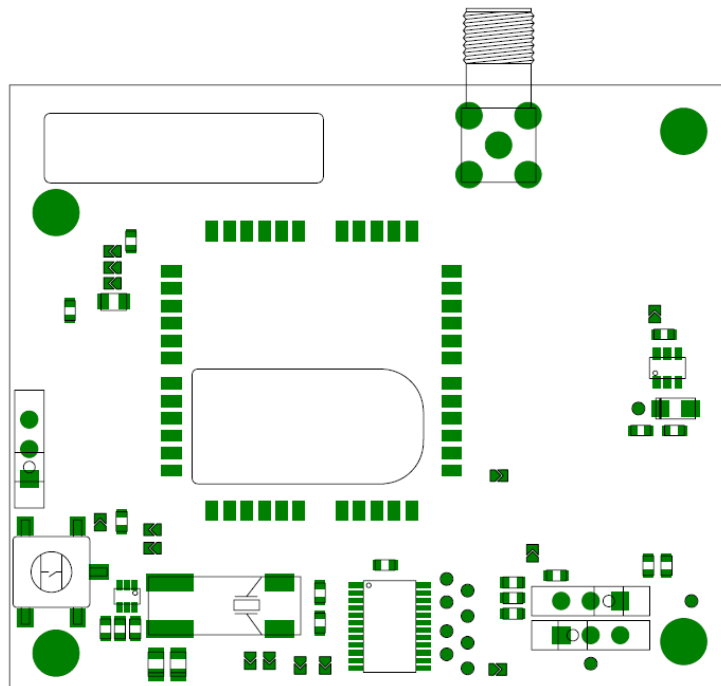

Figure 33. WISMO Series Socket-Up Board Assembly (Top View)

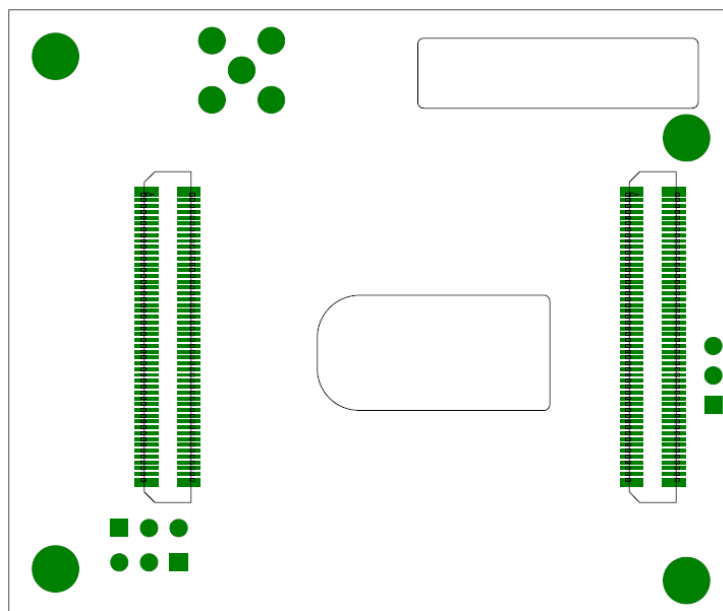
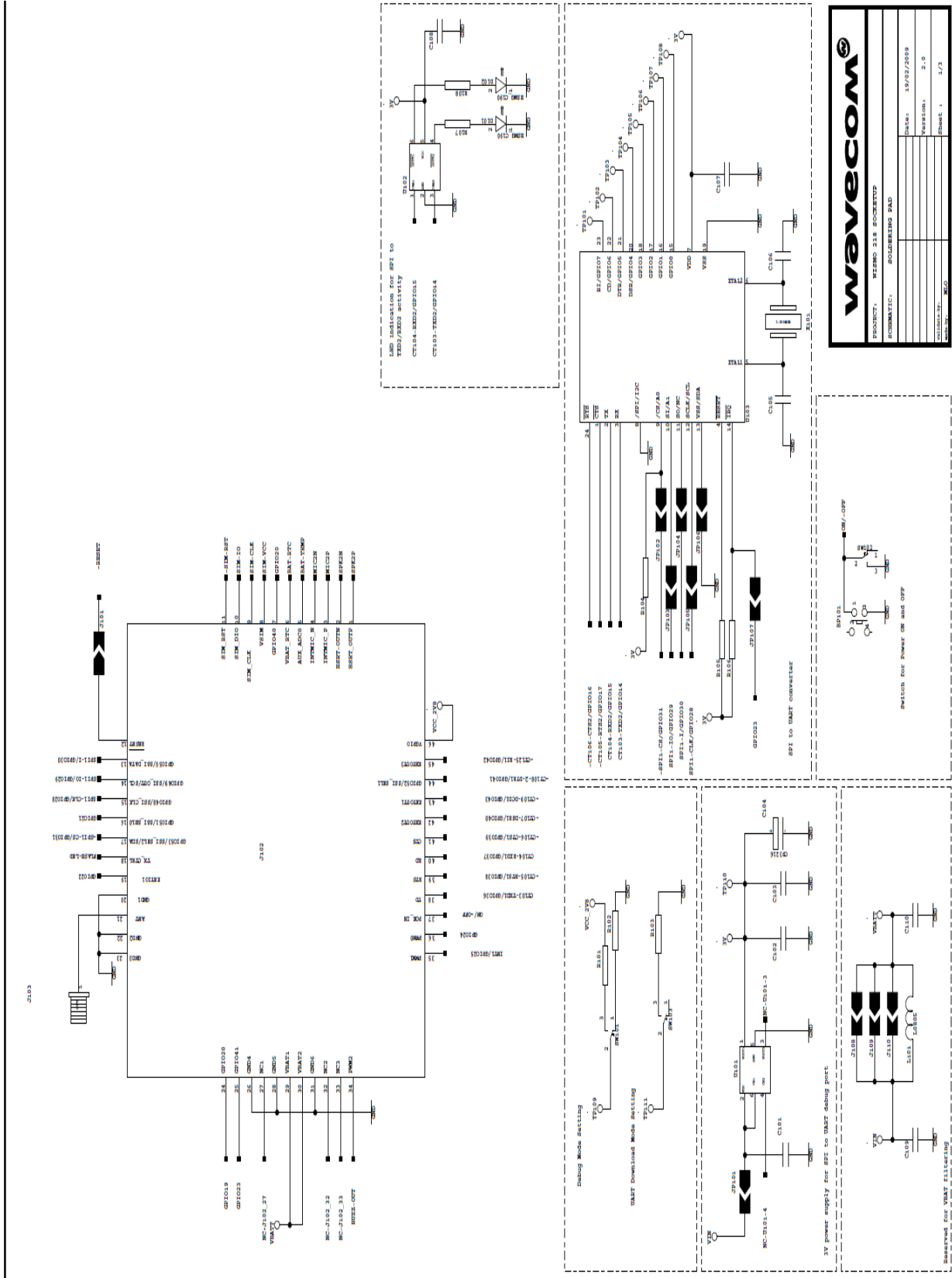
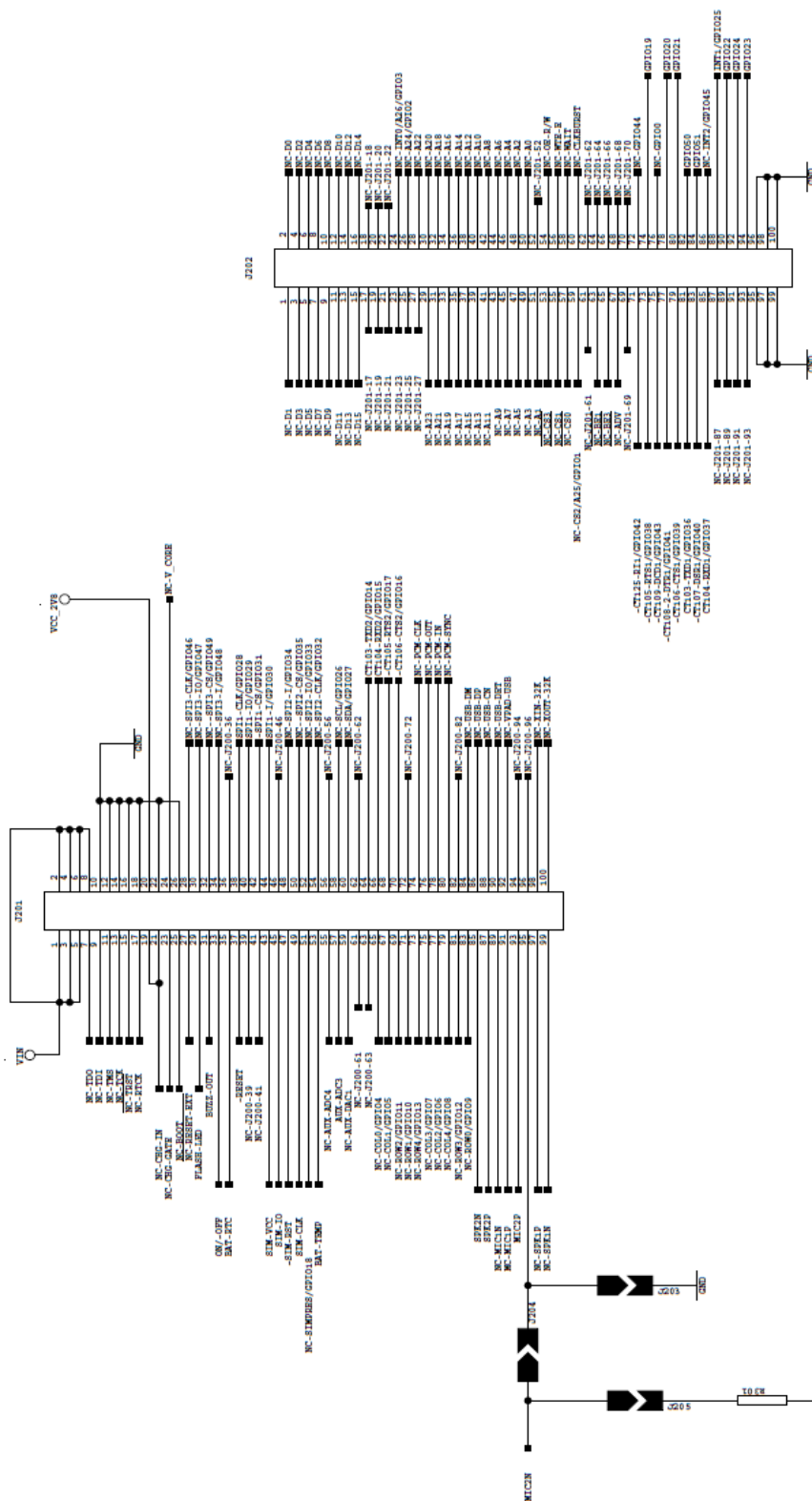

Figure 34. WISMO Series Socket-Up Board Assembly (Bottom View)



wavecom

PRODUCT: WISMO 2.1.8 (REV.02/09)
 SCHEMATIC: SCHEMATIC 2.1.8
 DATE: 10/02/2009
 VERSION: 2.0
 SHEET: 1 / 3



wavecom

PROJECT: WISMO 218 SOCKET UP

SCHEMATIC: WPMXX DEV KIT CONNECTOR

Date: 19/02/2009

Version: 2.0

File Name: W_...
Sheet: 3/3

- 21. SOCKET_UP_LOCATION@FILE
- 22. SOCKET_UP_LOCATION@FILE
- 23. SOCKET_UP_LOCATION@FILE
- 24. SOCKET_UP_LOCATION@FILE

