



**ESD-9950 96 x 96 1/4 DIN  
With Analogue Set, ON / OFF or Time  
Proportional Digital & Analogue Temperature  
Controller**

- 4 Digits Display
- J type Thermocouple Input or,  
K type Thermocouple Input or,  
R type Thermocouple Input or,  
S type Thermocouple Input or,  
2 or 3-wire PT 100 Input (It must be determined in order)
- Adjustable Hysteresis Value with DIP Switch for ON/OFF Control
- Adjustable ON/OFF or Time-Proportional Operation for ON/OFF Control
- Adjustable Set Offset Value

## ABOUT INSTRUCTION MANUAL

Instruction manual of ESD-9950 Digital & Analogue Temperature Controller consists of two main sections. Explanation of these sections are below. Also, there are other sections which include order information and technical specifications of the device. All titles and page numbers in instruction manual are in “**CONTENTS**” section. User can reach to any title with section number.

### **Installation:**

In this section, physical dimensions of the device, panel mounting, electrical wiring, physical and electrical installation of the device to the system are explained.

### **Operation :**

In this section, user interface of the device, definitions of operation form are explained.

Also in these sections, there are warnings to prevent serious injury while doing the physical and electrical mounting or using the device.

Explanation of the symbols which are used in these sections are given below.



This symbol is used for safety warnings. User must pay attention to these warnings.



This symbol is used to determine the dangerous situations as a result of an electric shock. User must pay attention to these warnings definitely.



This symbol is used to determine the important notes about functions and usage of the device.

# CONTENTS

<b>1.PREFACE</b> .....	Page	5
1.1 GENERAL SPECIFICATIONS		
1.2 ORDERING INFORMATION		
1.3 WARRANTY		
1.4 MAINTENANCE		
<b>2.INSTALLATION</b> .....	Page	7
2.1 GENERAL DESCRIPTION		
2.2 DIMENSIONS		
2.3 PANEL CUT-OUT		
2.4 ENVIRONMENTAL RATINGS		
2.5 PANEL MOUNTING		
2.6 INSTALLATION FIXING CLAMP		
2.7 REMOVING FROM THE PANEL		
<b>3.ELECTRICAL WIRINGS</b> .....	Page	12
3.1 TERMINAL LAYOUT AND CONNECTION INSTRUCTIONS		
3.2 ELECTRICAL WIRING DIAGRAM		
3.3 VIEW OF THE DEVICE LABEL		
3.4 SUPPLY VOLTAGE INPUT CONNECTION OF THE DEVICE		
3.5 TEMPERATURE SENSOR INPUT CONNECTION		
3.5.1 TC (THERMOCOUPLE) CONNECTION		
3.5.2 RTD CONNECTION		
3.6 GALVANIC ISOLATION TEST VALUES OF ESD-9950 DIGITAL & ANALOGUE TEMPERATURE CONTROLLER		
3.7 RELAY OUTPUT CONNECTION		
3.8 SSR DRIVER OUTPUT CONNECTION		
<b>4.FRONT PANEL DEFINITION AND OPERATION SETTINGS</b> .....	Page	19
4.1 FRONT PANEL DEFINITION		
4.2 OPERATION SETTINGS		
4.2.1 SET VALUES		
4.2.2.ON/OFF, TIME PROPORTIONAL OPERATION FORM SELECTION		
4.2.3 ADJUSTMENT OF HYSTERESIS VALUE FOR ON/OFF CONTROL		
4.2.4 ADJUSTMENT OF CONTROL PERIOD FOR TIME PROPORTIONAL CONTROL		
4.2.5 ADJUSTMENT OF SET OFFSET VALUE		
<b>5.FAILURE MESSAGES IN ESD-9950 DIGITAL &amp; ANALOGUE TEMPERATURE CONTROLLER....</b>	Page	25
<b>6.SPECIFICATIONS</b> .....	Page	26

## EU DECLARATION OF CONFORMITY

**Manufacturer's Name** : EMKO ELEKTRONIK A.S.  
**Manufacturer's Address** : DOSAB, Karanfil Sk., No:6,  
16369 Bursa, TURKEY

---

The manufacturer hereby declares that the product:

**Product Name** : Digital & Analogue Temperature Controller  
**Type Number** : ESD-9950  
**Product Category** : Electrical equipment for measurement, control and laboratory use

Conforms to the following directives :

2006 / 95 / EC The Low Voltage Directive

2004 / 108 / EC The Electromagnetic Compatibility Directive

has been designed and manufactured to the following specifications:

EN 61000-6-4:2007 EMC Generic Emission Standard for Industrial Environments

EN 61000-6-2:2005 EMC Generic Immunity Standard for Industrial Environments

EN 61010-1:2001 Safety Requirements for electrical equipment for measurement, control and laboratory use

---

### When and Where Issued

16<sup>th</sup> October 2009

Bursa-TURKEY

### Authorized Signature

Name : Serpil YAKIN

Position : Quality Manager

## 1.Preface

ESD Series Digital & Analogue Temperature Controllers are designed for measuring and controlling temperature. They can be used in many applications with their simple and easy to use properties, On / Off and time proportional control form.

Some application fields which they are used are below:

### Application Fields

Glass  
Plastic  
Petro-Chemistry  
Textile  
Automotive  
Machine production industries

## 1.1 General Specifications

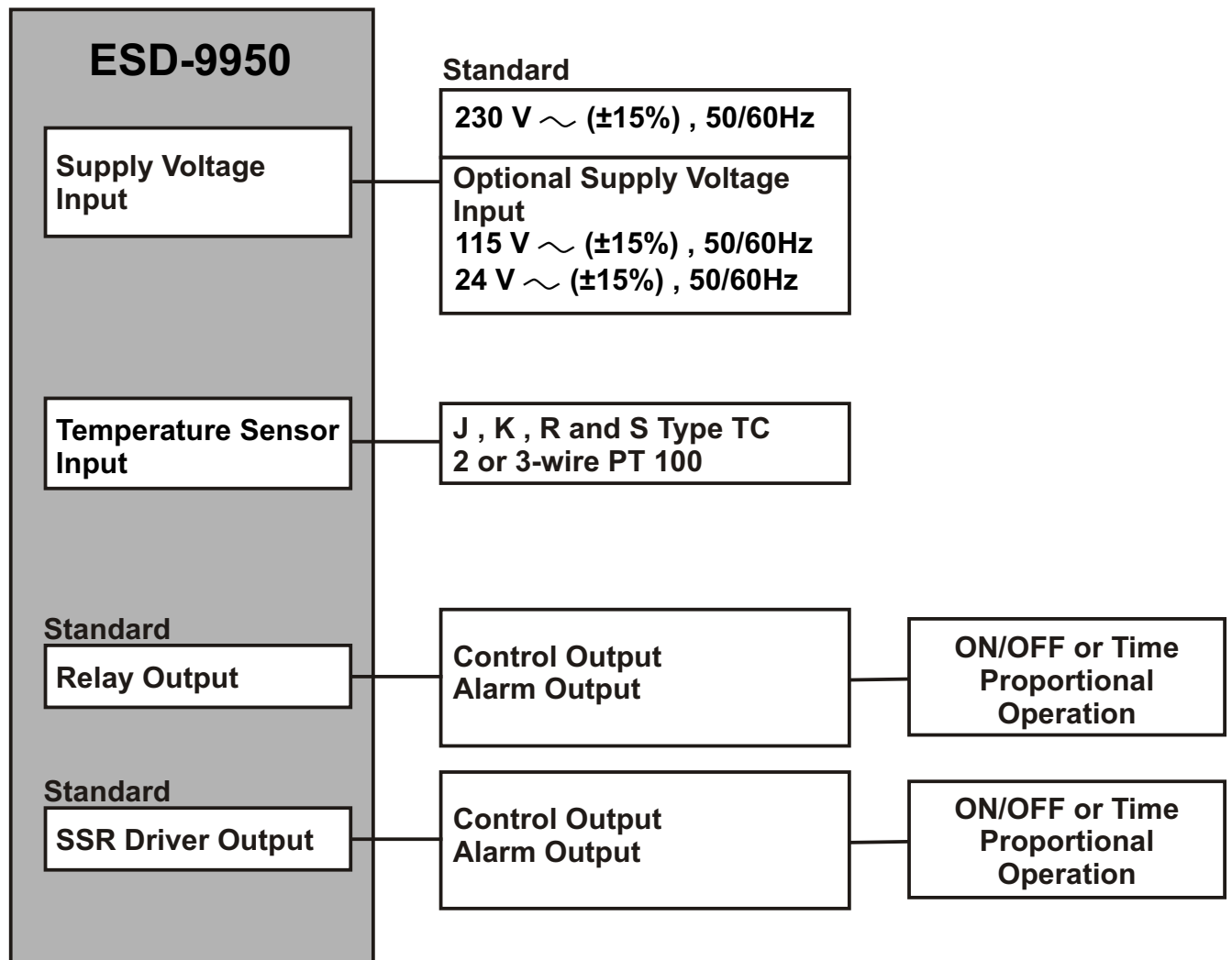

## 1.2 Ordering Information

<b>ESD-9950</b> (96x96 1/4 DIN)	A	BC	D	E	/	FG	HI	/	U	V	W	Z
			0	6	/	00	00	/			0	0

A	Supply Voltage
3	24V ~ (±15%) 50/60Hz
4	115V ~ (±15%) 50/60Hz
5	230V ~ (±15%) 50/60Hz
9	Customer

BC	Input Type	Scale(°C)
01	PT 100 , IEC751(ITS90)	-100.0°C 100.0°C
02	PT 100 , IEC751(ITS90)	0.0°C 200.0°C
03	PT 100 , IEC751(ITS90)	0°C 400°C
04	J ,Fe CuNi IEC584.1(ITS90)	0°C 400°C
05	J ,Fe CuNi IEC584.1(ITS90)	0°C 800°C
06	K ,NiCr Ni IEC584.1(ITS90)	0°C 1200°C
07	S ,Pt10%Rh Pt IEC584.1(ITS90)	0°C 1600°C
08	R ,Pt13%Rh Pt IEC584.1(ITS90)	0°C 1600°C

E	Output-1
6	Relay & SSR (Configurable)

U	Hysteresis
0	0.25% of full scale
1	0.5% of full scale
2	1% of full scale
3	2% of full scale

V	Control Period
1	1 second      SSR Driver Output
2	5 seconds      SSR Driver and Relay Output
3	10 seconds     SSR Driver and Relay Output
4	20 seconds     SSR Driver and Relay Output

All order information of ESD-9950 Digital & Analogue Temperature Controller are given on the table at left. User may form appropriate device configuration from information and codes that at the table and convert it to the ordering codes.

Firstly, supply voltage then other specifications must be determined. Please fill the order code blanks according to your needs.

Please contact us, if your needs are out of the standards.



~ Symbol means Vac,  
 --- Symbol means Vdc

## 1.3 Warranty

EMKO Elektronik warrants that the equipment delivered is free from defects in material and workmanship. This warranty is provided for a period of two years. The warranty period starts from the delivery date. This warranty is in force if duty and responsibilities which are determined in warranty document and instruction manual performs by the customer completely.

## 1.4 Maintenance

Repairs should only be performed by trained and specialized personnel. Cut power to the device before accessing internal parts.

Do not clean the case with hydrocarbon-based solvents (Petrol, Trichlorethylene etc.). Use of these solvents can reduce the mechanical reliability of the device. Use a cloth dampened in ethyl alcohol or water to clean the external plastic case.

## 2. Installation



Before beginning installation of this product, please read the instruction manual and warnings below carefully.

In package ,

- One piece unit
- Two pieces mounting clamps
- One piece instruction manual

A visual inspection of this product for possible damage occurred during shipment is recommended before installation. It is your responsibility to ensure that qualified mechanical and electrical technicians install this product.

If there is danger of serious accident resulting from a failure or defect in this unit, power off the system and separate the electrical connection of the device from the system.

The unit is normally supplied without a power switch or a fuse. Use power switch and fuse as required.

Be sure to use the rated power supply voltage to protect the unit against damage and to prevent failure.

Keep the power off until all of the wiring is completed so that electric shock and trouble with the unit can be prevented.

Never attempt to disassemble, modify or repair this unit. Tampering with the unit may results in malfunction, electric shock or fire.

Do not use the unit in combustible or explosive gaseous atmospheres.

During the equipment is putted in hole on the metal panel while mechanical installation some metal burrs can cause injury on hands, you must be careful.

Montage of the product on a system must be done with it's own fixing clamps. Do not do the montage of the device with inappropriate fixing clamps. Be sure that device will not fall while doing the montage.

It is your responsibility if this equipment is used in a manner not specified in this instruction manual.

## 2.1 General Description

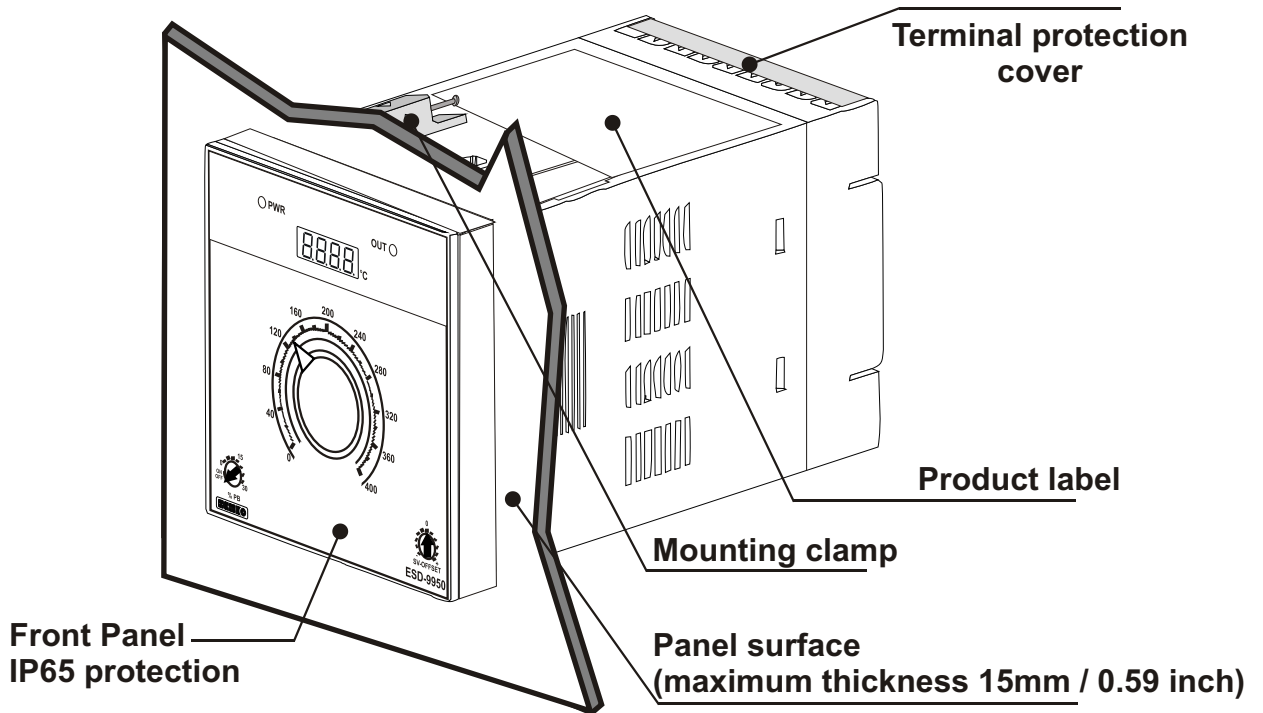

## 2.2 Dimensions

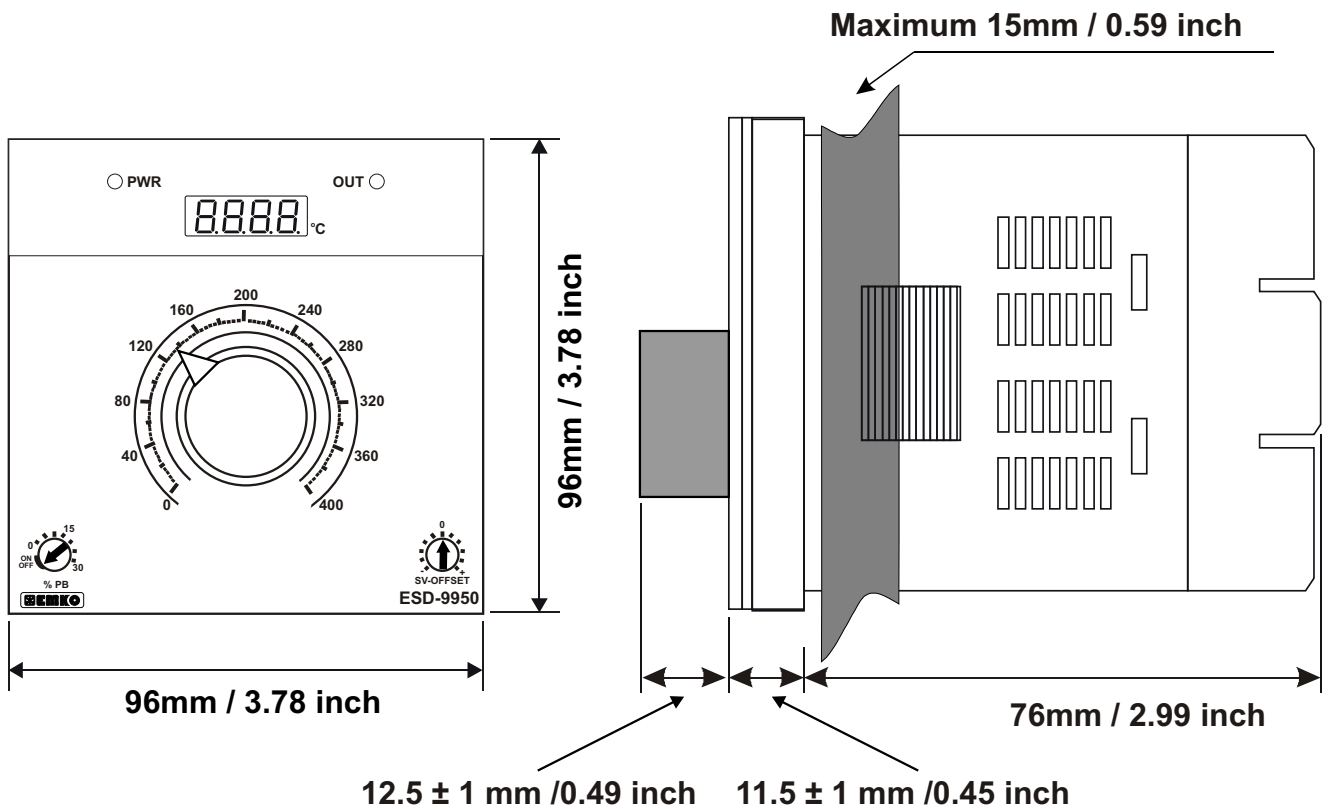

**2.3 Panel Cut-Out**

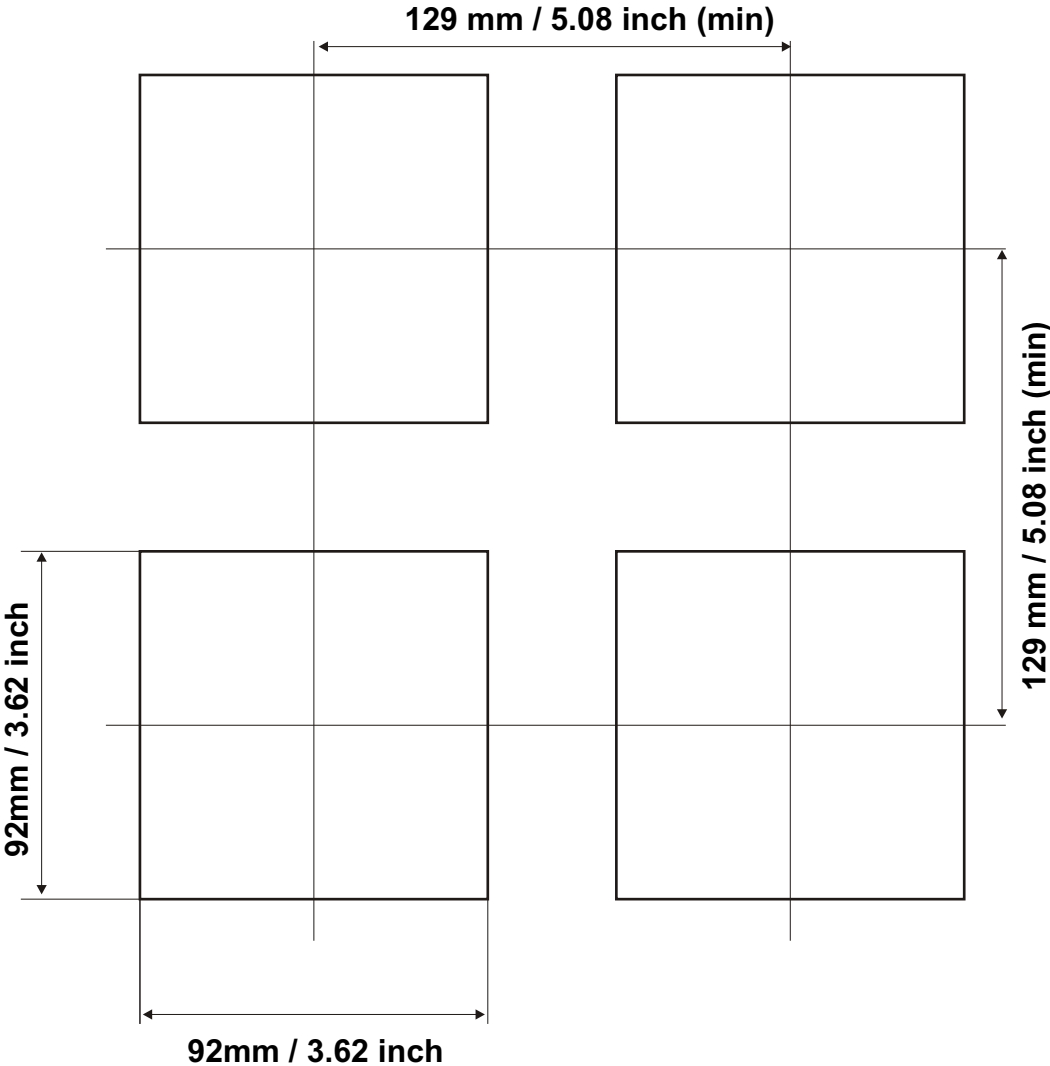

## 2.4 Environmental Ratings

### Operating Conditions



**Operating Temperature** : 0 to 50 °C



**Max. Operating Humidity** : 90% Rh (non-condensing)



**Altitude** : Up to 2000m.



#### **Forbidden Conditions:**

**Corrosive atmosphere**

**Explosive atmosphere**

**Home applications (The unit is only for industrial applications)**

## 2.5 Panel Mounting

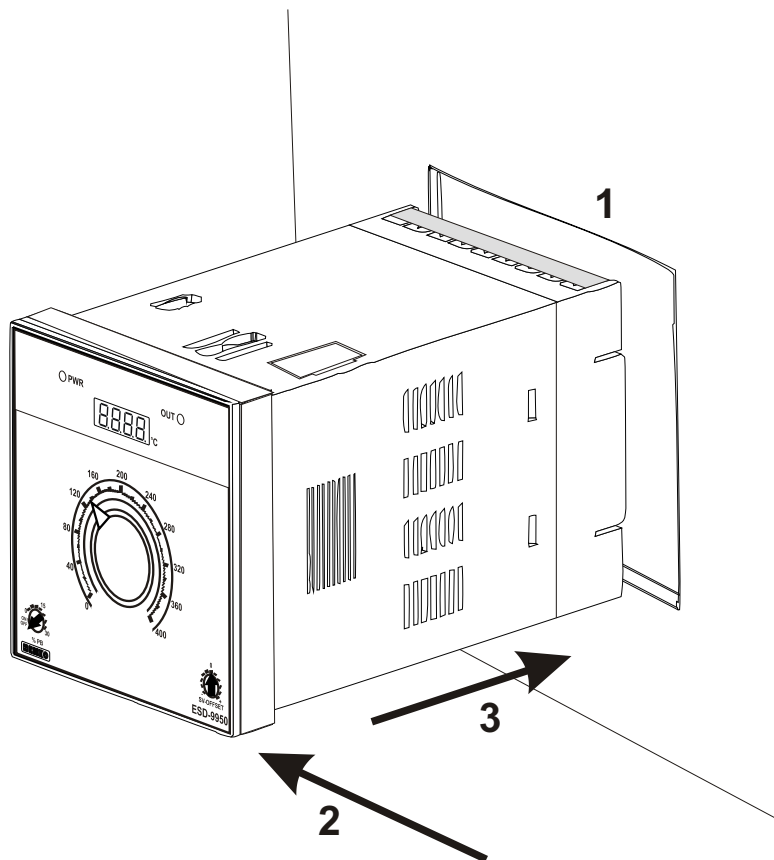

1-Before mounting the device in your panel, make sure that the cut-out is of the right size.

2-Check front panel gasket position

3-Insert the device through the cut-out. If the mounting clamps are on the unit, put out them before inserting the unit to the panel.



During installation into a metal panel, care should be taken to avoid injury from metal burrs which might be present. The equipment can loosen from vibration and become dislodged if installation parts are not properly tightened. These precautions for the safety of the person who does the panel mounting.

## 2.6 Installation Fixing Clamp

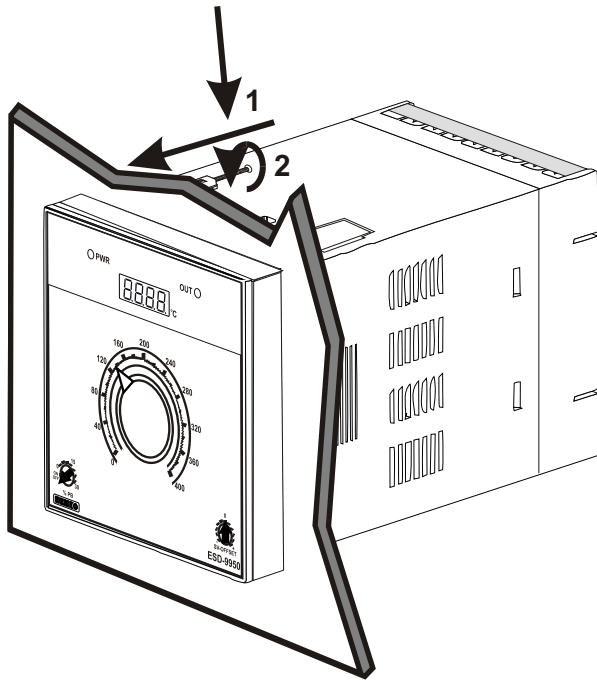

The unit is designed for panel mounting.

1-Insert the unit in the panel cut-out from the front side.

2- Insert the mounting clamps to the holes that located top and bottom sides of device and screw up the fixing screws until the unit completely immobile within the panel



**Montage of the unit to a system must be done with it's own fixing clamps. Do not do the montage of the device with inappropriate fixing clamps. Be sure that device will not fall while doing the montage.**

## 2.7 Removing from the Panel



**Before starting to remove the unit from panel, power off the unit and the related system.**

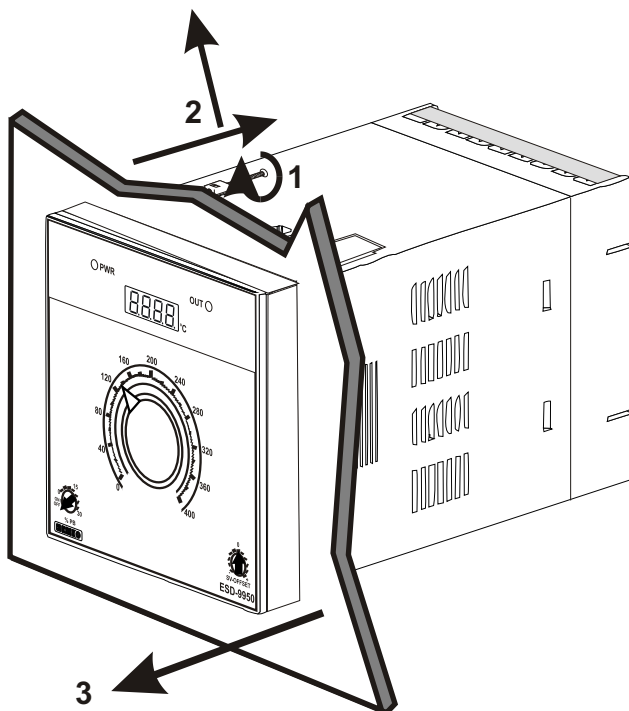

1-Loosen the screws.

2-Pull mounting clamps from top and bottom fixing sockets.

3-Pull the unit through the front side of the panel

### 3. Electrical Wirings



You must ensure that the device is correctly configured for your application. Incorrect configuration could result in damage to the process being controlled, and/or personal injury. It is your responsibility, as the installer, to ensure that the configuration is correct.

Device parameters has factory default values. These parameters must be set according to the system's needs.



Only qualified personnel and technicians should work on this equipment. This equipment contains internal circuits with voltage dangerous to human life. There is severe danger for human life in the case of unauthorized intervention.



Be sure to use the rated power supply voltage to protect the unit against damage and to prevent failure.



Keep the power off until all of the wiring is completed so that electric shock and trouble with the unit can be prevented.

#### 3.1 Terminal Layout and Connection Instructions

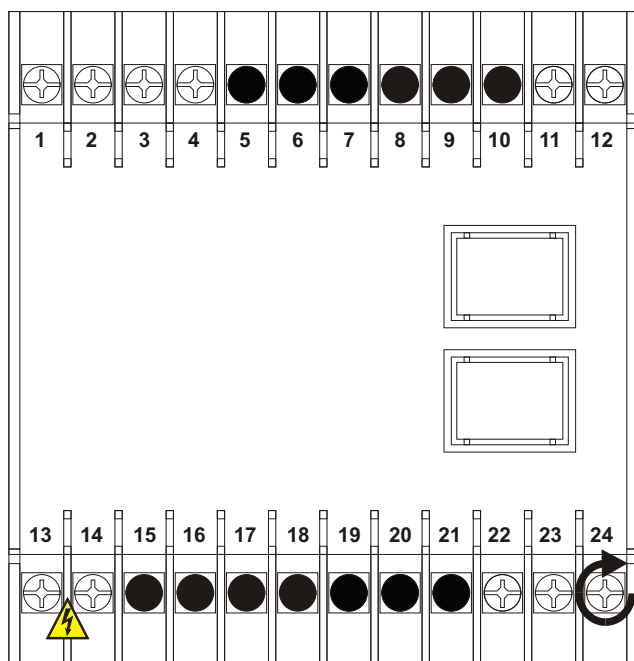

0.5Nm

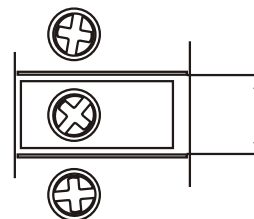

6 mm / 0.236 inch  
Wire Size:  
18 AWG / 1 mm<sup>2</sup>  
Solid / Stranded



24 screws terminal  
M3



Empty terminals



Torque 0.5 Nm



Screw driver 0.8x3mm

### 3.2 Electrical Wiring Diagram



Electrical wiring of the device must be the same as 'Electrical Wiring Diagram' below to prevent damage to the process being controlled and personnel injury.

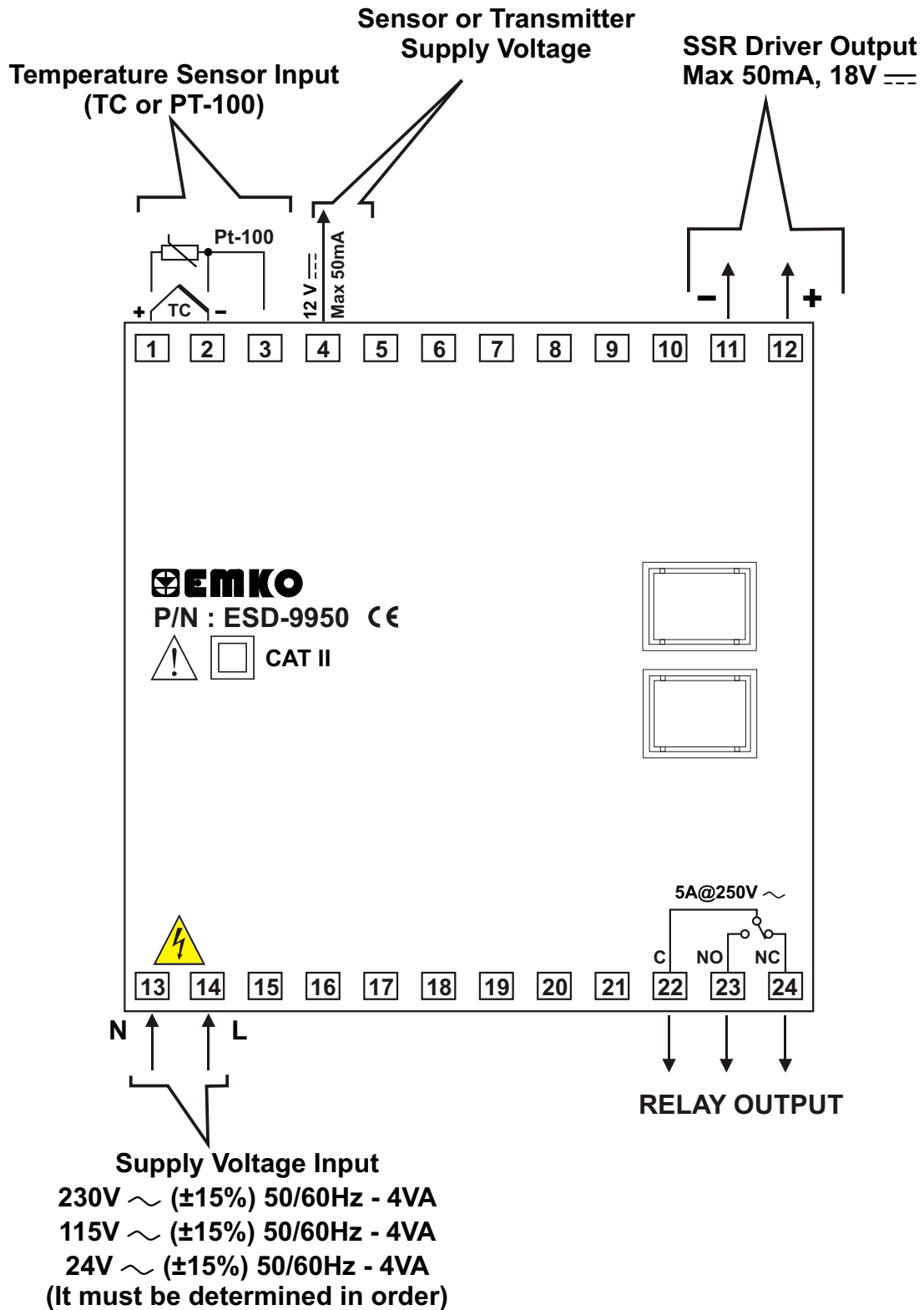

Temperature Sensor Input is in CAT II class

### 3.3 View of the Device Label

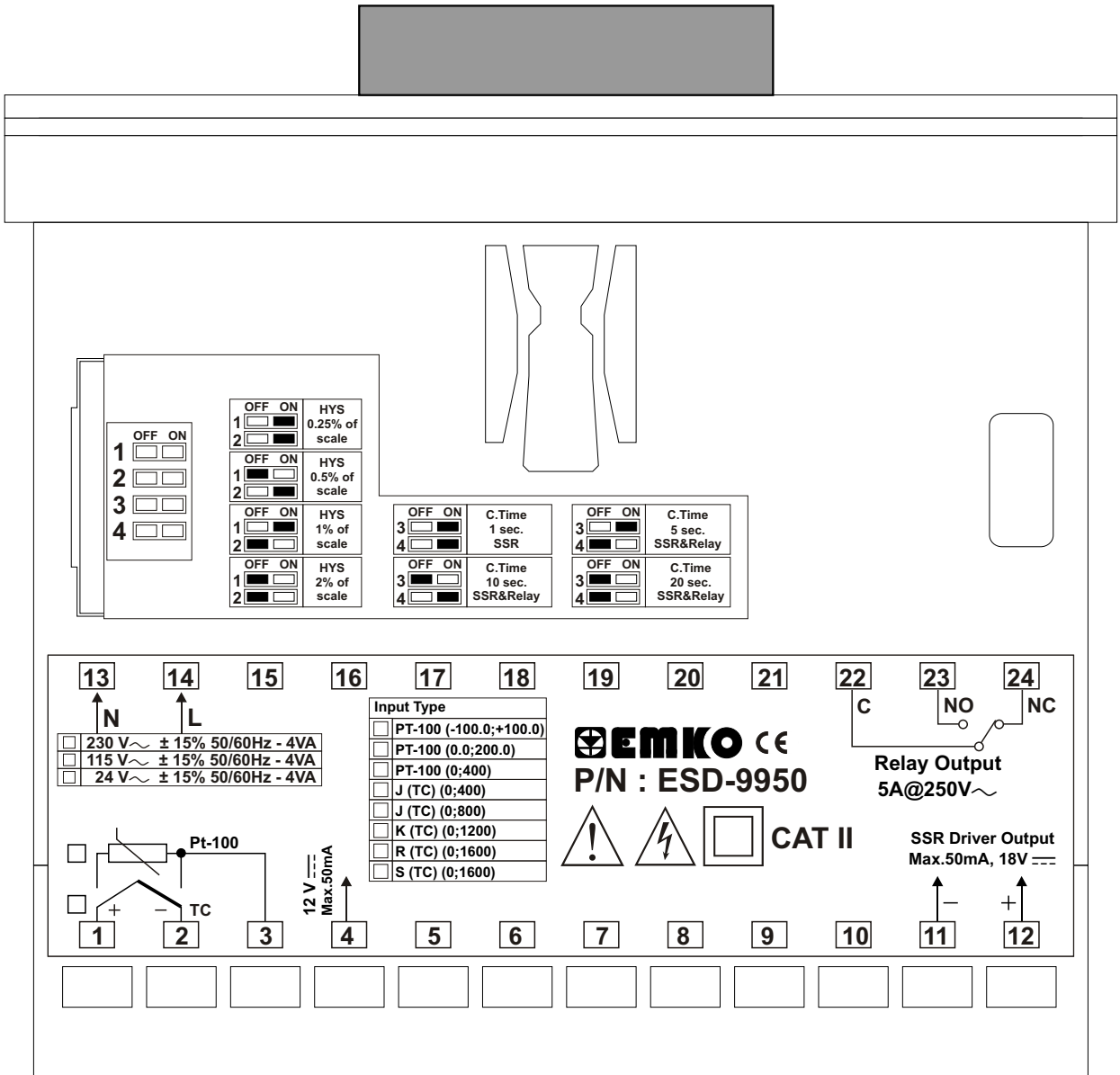

### 3.4 Supply Voltage Input Connection of the Device

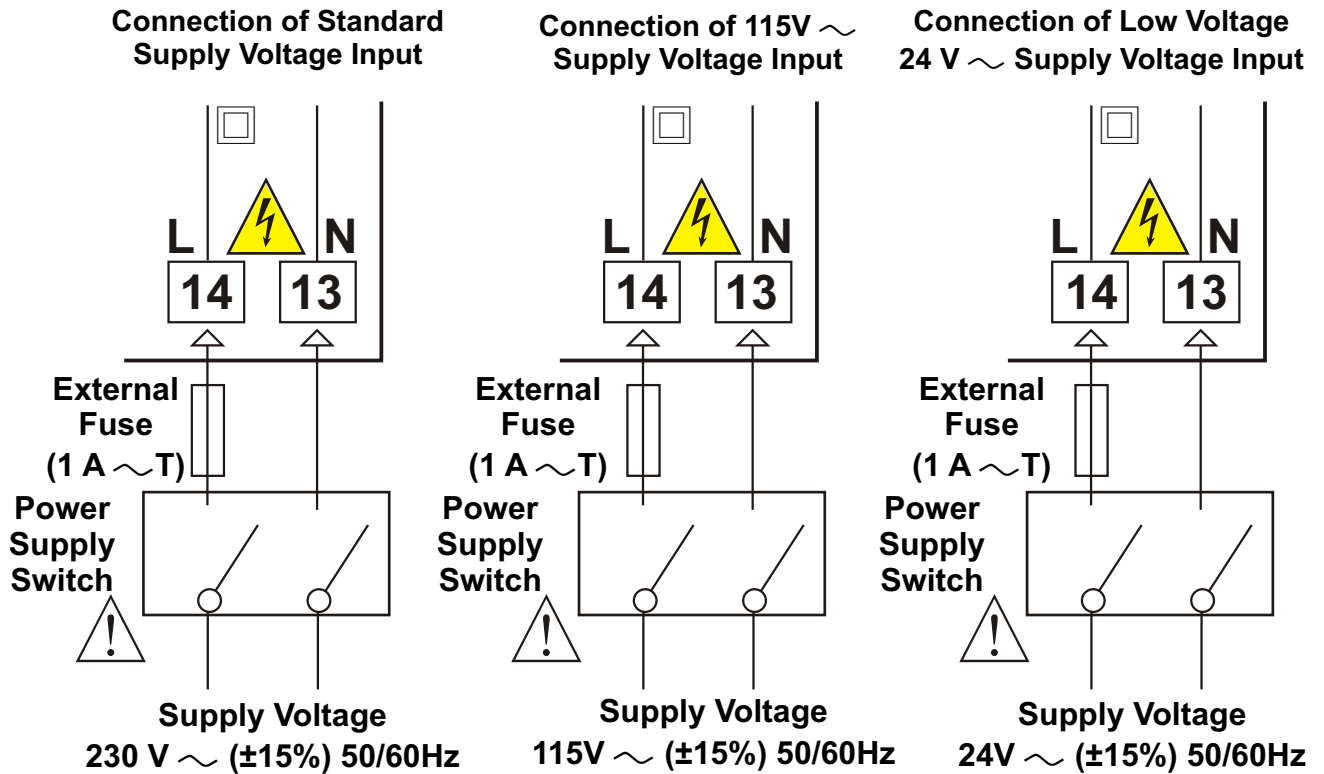

Supply voltage range must be determined in order. While installing the unit, supply voltage range must be controlled and appropriate supply voltage must be applied to the unit. Controlling prevents damages in unit and system and possible accidents as a result of incorrect supply voltage.



There is no power switch or fuse on the device. So a power switch and a fuse must be added to the supply voltage input. Power switch and fuse must be put to a place where user can reach easily.



Power switch must be two poled for separating phase and neutral. On/Off condition of power switch is very important in electrical connection. On/Off condition of power switch must be signed for preventing the wrong connection.



External fuse must be on phase connection in  $\sim$  supply input.

## 3.5 Temperature Sensor Input Connection

### 3.5.1 TC (Thermocouple) Connection

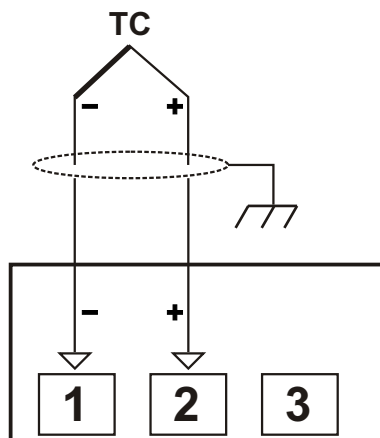

Connect the wires with the polarity as shown in the figure left.

- i** Always use compensation wire corresponding to the thermocouple used. If present, the shield must be connected to a proper ground.
- i** Input resistance is greater than 10M

### 3.5.2 RTD Connection

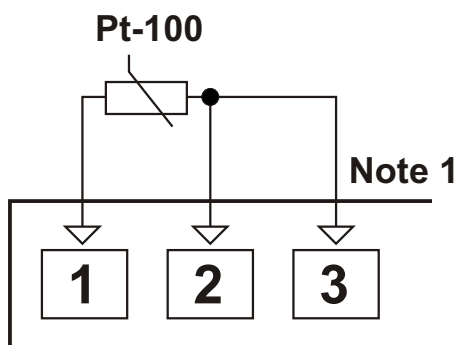

3-wire Pt-100 connection  
(with line compensation)  
(Max. Line impedance is 10 Ω)

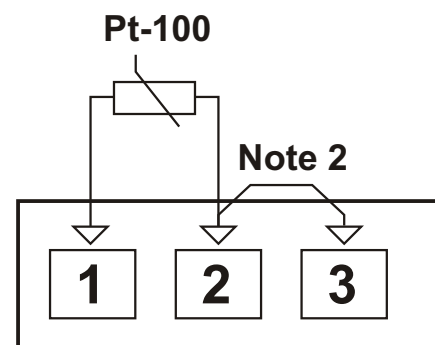

2-wire Pt-100 connection  
(without line compensation)

**Note 1 :** In 3-wire system, use always cables of the same diameter (min 1mm<sup>2</sup>) Always use wires of the same gauge and type whether a 2-wire or 3-wire system.

**Note 2 :** Install a jumper between terminals 2 and 3 when using a 2-wire RTD.

**Note 3 :** If the distance is longer than 10 meters, use 3-wire system

- i** Input resistance is greater than 10M

### 3.6 Galvanic Isolation Test Values of ESD-9950 Digital & Analogue Temperature Controller

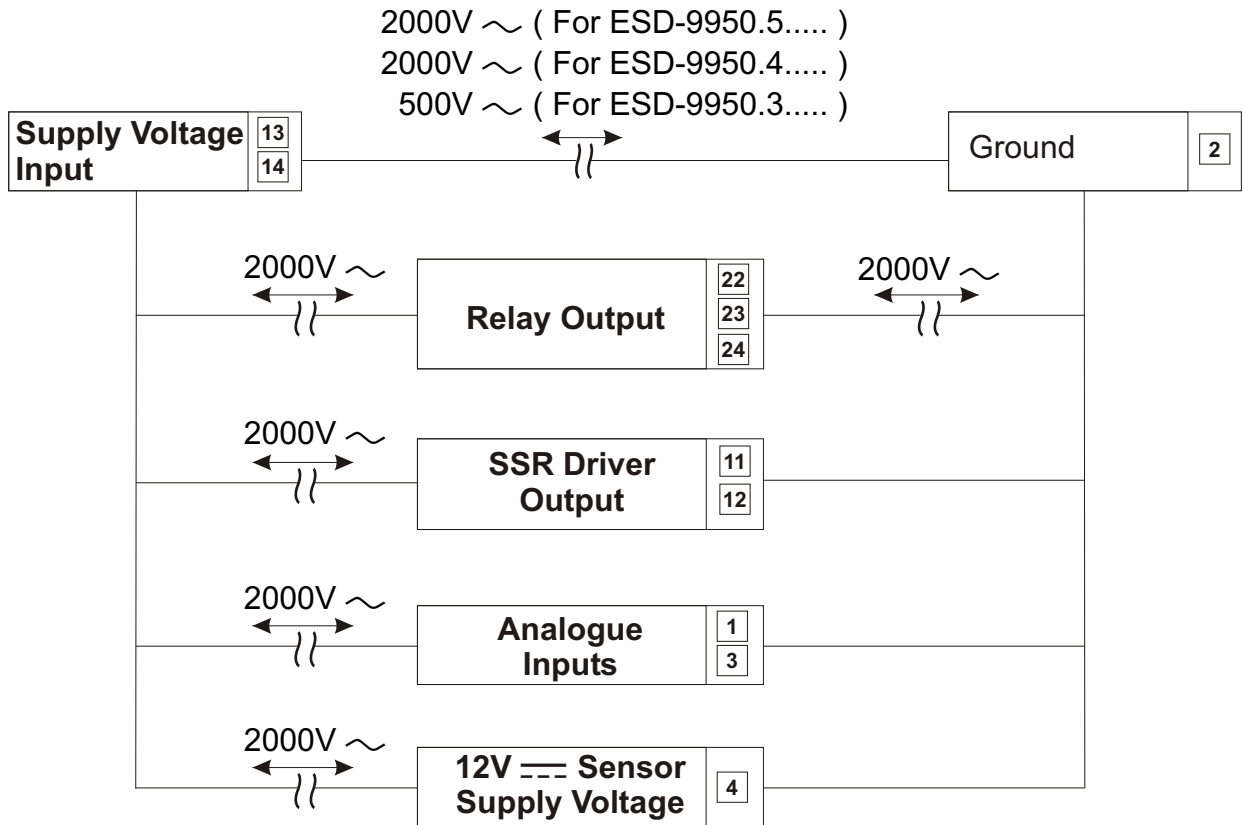

### 3.7 Relay Output Connection

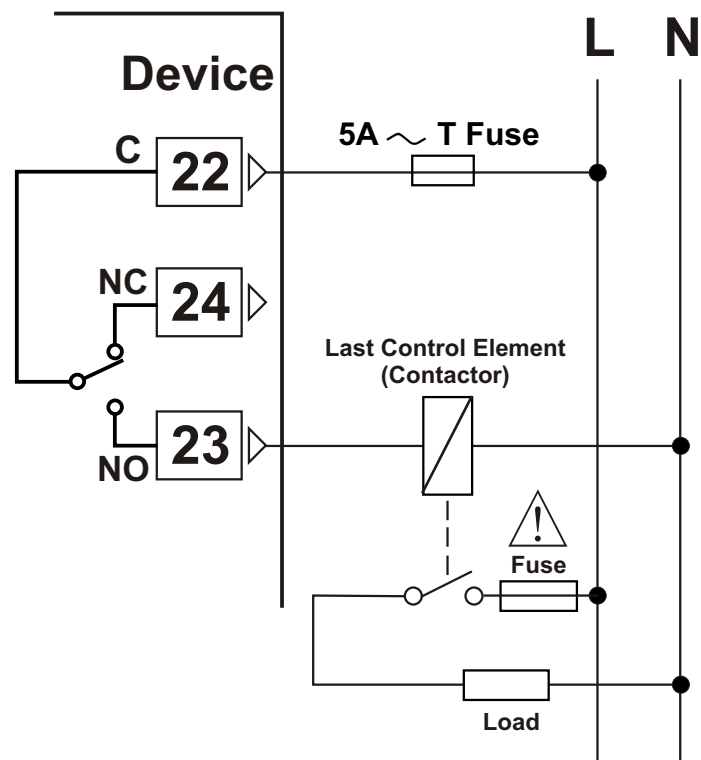

Fuses must be selected according to the applications

### 3.8 SSR Driver Output Connection

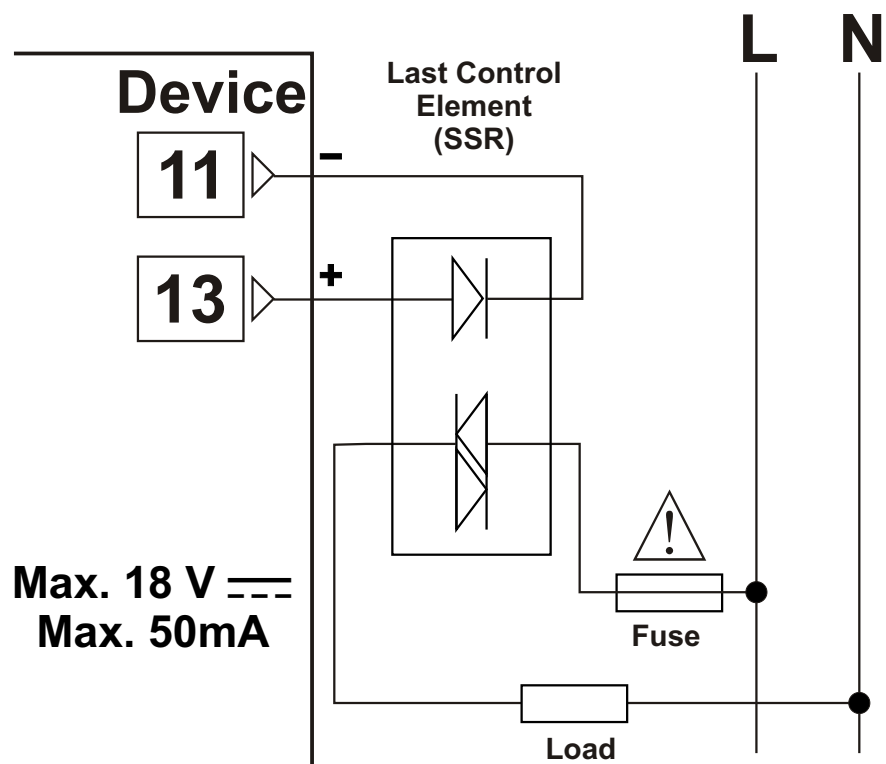

Fuses must be selected according to the applications

## 4. Front Panel Definition and Operation Settings

### 4.1 Front Panel Definition

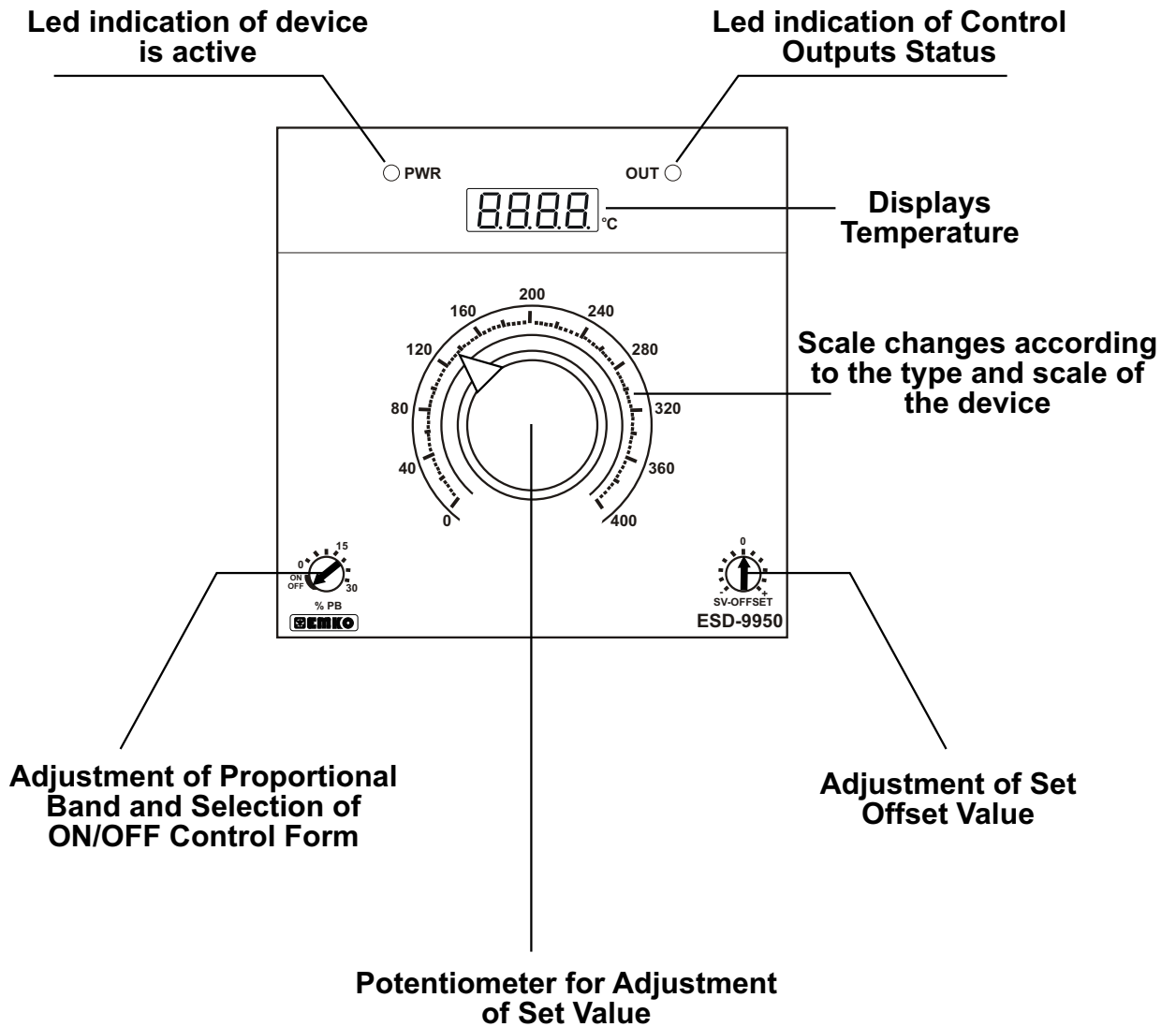

## 4.2 Operation Settings

### 4.2.1 Set Values

Set value can be adjusted with Set Value Adjustment Potentiometer that is on the front panel. Set value range changes according to the type and scale of the device. Minimum and maximum values of Set value according to the device type are given below:

#### Set Values according to the Type and Scale of the Device

For PT-100 ( -100.0 to 100.0 )°C
For PT-100 ( 0.0 to 200.0 )°C
For PT-100 ( 0 to 400 )°C
For J Type TC ( 0 to 400 )°C
For J Type TC ( 0 to 800 )°C
For K Type TC ( 0 to 1200 )°C
For R Type TC ( 0 to 1600 )°C
For S Type TC ( 0 to 1600 )°C

### 4.2.2 ON/OFF , Time Proportional Operation Form Selection

Operation form can be adjusted with proportional band adjustment and ON/OFF Control Form selection trimpot that is on the front panel.

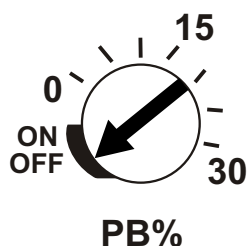

Trimpot is adjusted to point out ON/OFF part for ON/OFF Control form.

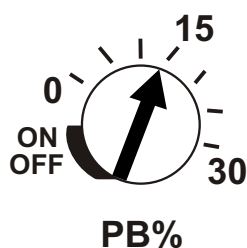

Trimpot is adjusted to point out different from ON/OFF part for proportional operation. Proportional Band Value can be adjusted from 0% to 30% of full scale.

Minimum and maximum value of proportional band according to the type and scale of the device are given below:

#### Proportional Band Values according to the type and scale of the device

For PT-100 ( -100.0 to 100.0 )°C scaled device: 0.0 to 60.0°C
For PT-100 ( 0.0 to 200.0 )°C scaled device : 0.0 to 60.0°C
For PT-100 ( 0 to 400 )°C scaled device : 0 to 120°C
For J Type TC ( 0 to 400 )°C scaled device : 0 to 120°C
For J Type TC ( 0 to 800 )°C scaled device : 0 to 240°C
For K Type TC ( 0 to 1200 )°C scaled device : 0 to 360°C
For R Type TC ( 0 to 1600 )°C scaled device : 0 to 480°C
For S Type TC ( 0 to 1600 )°C scaled device : 0 to 480°C

## 4.2.3 Adjustment of Hysteresis Value for ON/OFF Control

In ON/OFF control algorithm, temperature value is tried to keep equal to set value by opening or closing completely last control element. ON/OFF controlled system, temperature value oscillates continuously. Temperature value's oscillation period or amplitude around set value changes according to controlled system. For reducing oscillation period of temperature value, a threshold zone is formed below or around set value and this zone is named hysteresis. Action of control output is described with figures below.

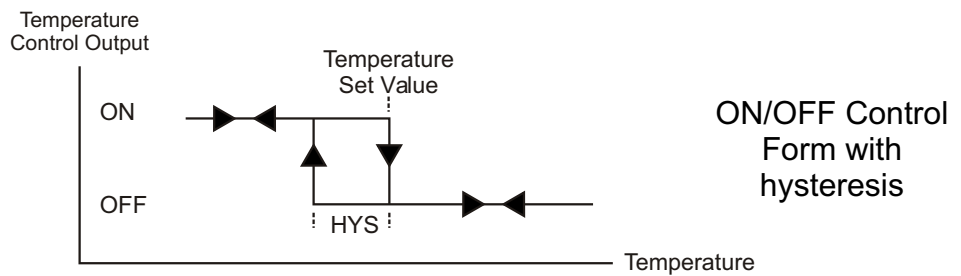
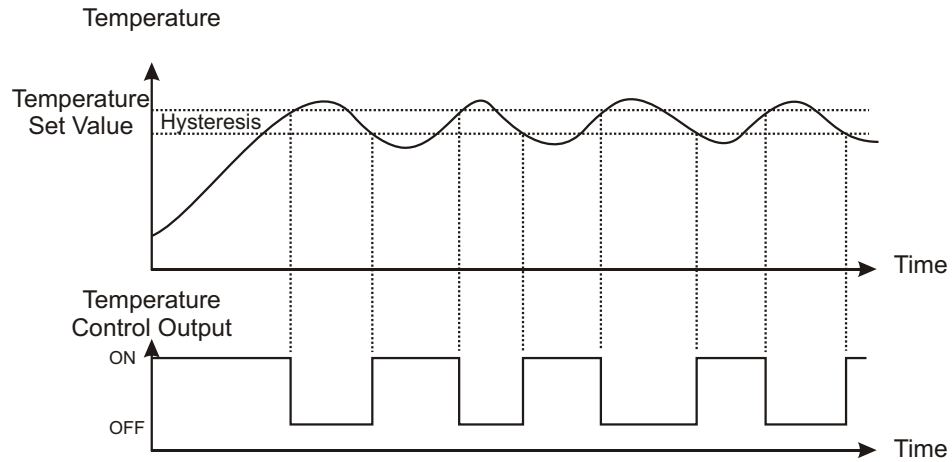

In operation with ON/OFF Control form; hysteresis value can be adjusted with DIP Switch on the device.

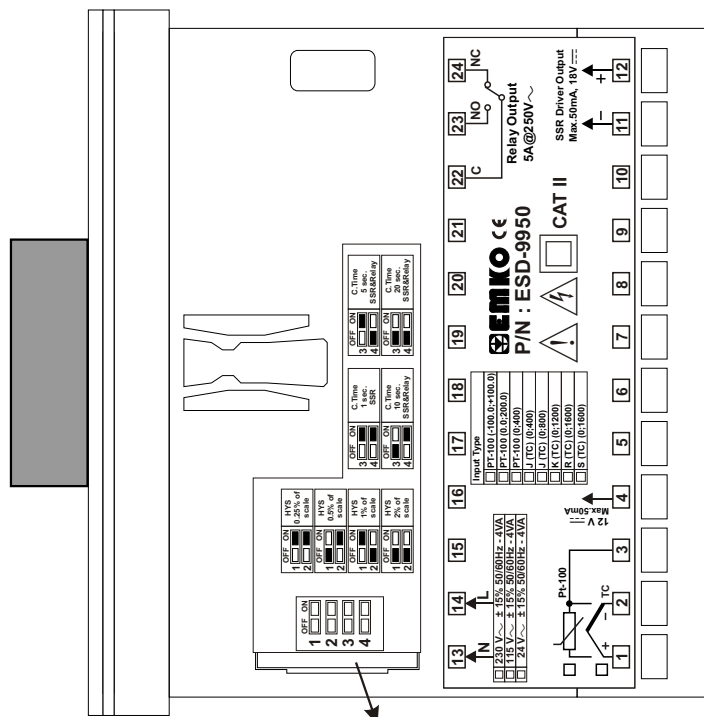

DIP Switch is under cover and cover is on top side of the device

## Hysteresis Value Selection

<b>OFF ON</b> 1 <input type="checkbox"/> <input checked="" type="checkbox"/> 2 <input type="checkbox"/> <input checked="" type="checkbox"/>	<b>0.25% of full scale is selected</b>
<b>OFF ON</b> 1 <input type="checkbox"/> <input checked="" type="checkbox"/> 2 <input checked="" type="checkbox"/> <input type="checkbox"/>	<b>0.5% of full scale is selected</b>
<b>OFF ON</b> 1 <input checked="" type="checkbox"/> <input type="checkbox"/> 2 <input type="checkbox"/> <input checked="" type="checkbox"/>	<b>1% of full scale is selected</b>
<b>OFF ON</b> 1 <input checked="" type="checkbox"/> <input type="checkbox"/> 2 <input checked="" type="checkbox"/> <input type="checkbox"/>	<b>2% of full scale is selected</b>

Minimum and maximum value of hysteresis according to the type and scale of the device are given below:

### If 0.25% of full scale is selected with DIP Switch, then hysteresis;

For PT-100 ( -100.0 to 100.0 )°C : ( 0.0 to 0.5 )°C
For PT-100 ( 0.0 to 200.0 )°C : (0.0 to 0.5)°C
For PT-100 ( 0 to 400 )°C : (0 to 1)°C
For J Type TC ( 0 to 400 )°C : (0 to 1)°C
For J Type TC ( 0 to 800 )°C : (0 to 2)°C
For K Type TC ( 0 to 1200 )°C : (0 to 3)°C
For R Type TC ( 0 to 1600 )°C : (0 to 4)°C
For S Type TC ( 0 to 1600 )°C : (0 to 4)°C

### If 0.5% of full scale is selected with DIP Switch, then hysteresis;

For PT-100 ( -100.0 to 100.0 )°C : ( 0.0 to 1.0 )°C
For PT-100 ( 0.0 to 200.0 )°C : (0.0 to 1.0)°C
For PT-100 ( 0 to 400 )°C : (0 to 2)°C
For J Type TC ( 0 to 400 )°C : (0 to 2)°C
For J Type TC ( 0 to 800 )°C : (0 to 4)°C
For K Type TC ( 0 to 1200 )°C : (0 to 6)°C
For R Type TC ( 0 to 1600 )°C : (0 to 8)°C
For S Type TC ( 0 to 1600 )°C : (0 to 8)°C

### If 1% of full scale is selected with DIP Switch, then hysteresis;

For PT-100 ( -100.0 to 100.0 )°C : ( 0.0 to 2.0 )°C
For PT-100 ( 0.0 to 200.0 )°C : (0.0 to 2.0)°C
For PT-100 ( 0 to 400 )°C : (0 to 4)°C
For J Type TC ( 0 to 400 )°C : (0 to 4)°C
For J Type TC ( 0 to 800 )°C : (0 to 8)°C
For K Type TC ( 0 to 1200 )°C : (0 to 12)°C
For R Type TC ( 0 to 1600 )°C : (0 to 16)°C
For S Type TC ( 0 to 1600 )°C : (0 to 16)°C

### If 2% of full scale is selected with DIP Switch, then hysteresis;

For PT-100 ( -100.0 to 100.0 )°C : ( 0.0 to 4.0 )°C
For PT-100 ( 0.0 to 200.0 )°C : (0.0 to 4.0)°C
For PT-100 ( 0 to 400 )°C : (0 to 8)°C
For J Type TC ( 0 to 400 )°C : (0 to 8)°C
For J Type TC ( 0 to 800 )°C : (0 to 16)°C
For K Type TC ( 0 to 1200 )°C : (0 to 24)°C
For R Type TC ( 0 to 1600 )°C : (0 to 32)°C
For S Type TC ( 0 to 1600 )°C : (0 to 32)°C

## 4.2.4 Adjustment of Control Period for Time Proportional Control



In time proportional operation; Control Period is adjusted by changing the position of the DIP Switch that is on the device.

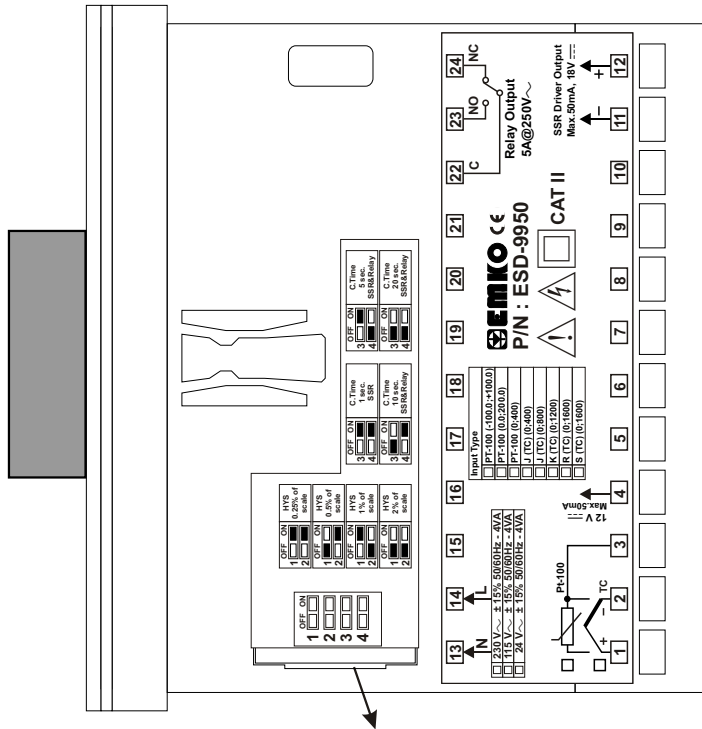

DIP Switch is under cover and cover is on top side of the device

### Control Period Selection

<p>OFF ON</p> <p>3 <input type="checkbox"/> <input checked="" type="checkbox"/></p> <p>4 <input type="checkbox"/> <input checked="" type="checkbox"/></p>	<p><b>1 Second</b> (For SSR Driver Output)</p>
<p>OFF ON</p> <p>3 <input type="checkbox"/> <input checked="" type="checkbox"/></p> <p>4 <input checked="" type="checkbox"/> <input type="checkbox"/></p>	<p><b>5 Seconds</b> (For SSR and Relay Output)</p>
<p>OFF ON</p> <p>3 <input checked="" type="checkbox"/> <input type="checkbox"/></p> <p>4 <input type="checkbox"/> <input checked="" type="checkbox"/></p>	<p><b>10 Seconds</b> (For SSR and Relay Output)</p>
<p>OFF ON</p> <p>3 <input checked="" type="checkbox"/> <input type="checkbox"/></p> <p>4 <input checked="" type="checkbox"/> <input type="checkbox"/></p>	<p><b>20 Seconds</b> (For SSR and Relay Output)</p>

### Temperature Control Output (%)

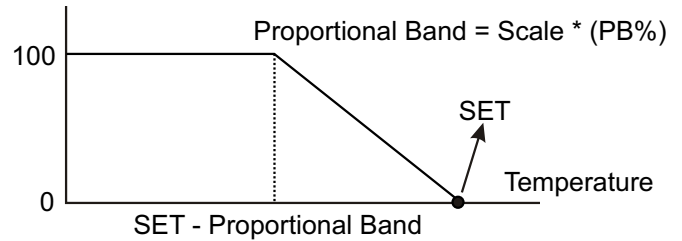

**Relay Output :** Output period must be short for stable process control. Relay must not be used in short output periods because of limited life of their relay contact (number of open/close events).

**SSR Output :** If short output period is needed in a system (approximately 1-2 seconds) SSR driver output module as last control element is recommended.

**Example :** For a (0 , 400°C) scaled device, proportional band is adjusted 15 with proportional band adjustment and ON/OFF control form trimpot, control period is adjusted 10 seconds with DIP switch. The system will give 100% output, until temperature is in proportional band, namely until temperature is 340°C ( $Scale * 15 / 100 = 400 * 15 / 100 = 60$ ). When temperature is being close to set value, %output is started to be reduced. In this case, when the device calculates 60% output, the system will be energised for 60% of device's control period. (For this example; 60% of 10 seconds = 6 seconds the system will be energised, but the system will not be energised for 4 seconds)

## 4.2.5 Adjustment of Set Offset Value

Set offset value can be adjusted with set offset trimpot that is located on front panel.

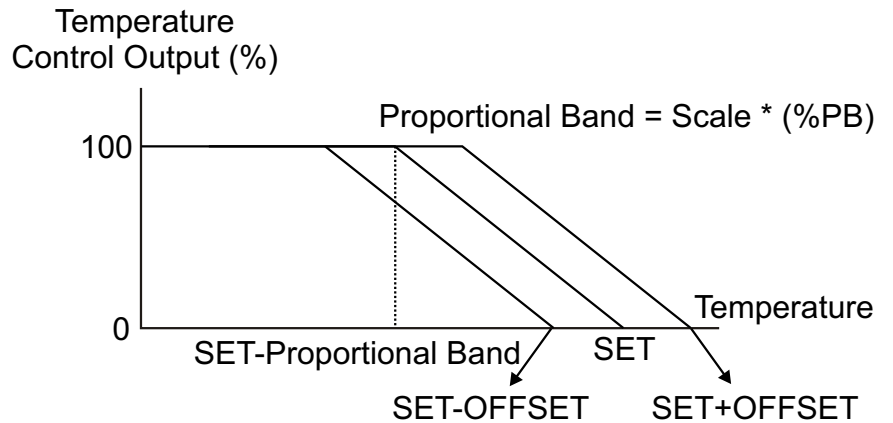
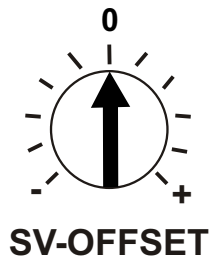

When temperature is not equal to SET value, to remove the difference between SET value and temperature and to make equal the temperature and SET value, Set offset is used. It can be adjusted from -20% to 20% of full scale.

Minimum and maximum value of Set offset value according to the type and scale of the device are given below:

### Set offset Values according to the type and scale of the device

For PT-100 ( -100.0 to 100.0 )°C scaled devices : (-20.0 to +20.0)°C
For PT-100 ( 0.0 to 200.0 )°C scaled devices : (-20.0 to +20.0)°C
For PT-100 ( 0 to 400 )°C scaled devices : (-8 to 8)°C
For J Type TC ( 0 to 400 )°C scaled devices : (-8 to 8)°C
For J Type TC ( 0 to 800 )°C scaled devices : (-16 to 16)°C
For K Type TC ( 0 to 1200 )°C scaled devices : (-24 to 24)°C
For R Type TC ( 0 to 1600 )°C scaled devices : (-32 to 32)°C
For S Type TC ( 0 to 1600 )°C scaled devices : (-32 to 32)°C

## 5. Failure Messages in ESD-9950 Digital & Analogue Temperature Controller

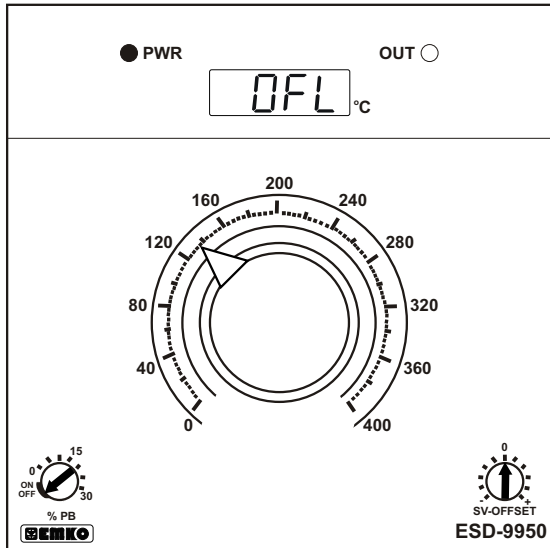

Sensor failure in analogue inputs.  
It occurs if  
Sensor connection is wrong or  
There is no sensor connection or  
The value on analogue input exceeds scale of the  
device.

## 6. Specifications

<b>Device Type</b>	: Digital & Analogue Temperature Controller
<b>Housing&amp;Mounting</b>	: 96mm x 96mm x 100mm 1/4 DIN 43700 plastic housing for panel mounting. Panel cut-out is 92x92mm.
<b>Protection Class</b>	: IP65 at front, IP20 at rear.
<b>Weight</b>	: Approximately 0.40 Kg.
<b>Environmental Ratings</b>	: Standard, indoor at an altitude of less than 2000 meters with none condensing humidity.
<b>Storage/Operating Temperature</b>	: -40 °C to +85 °C / 0 °C to +50 °C
<b>Storage/Operating Humidity</b>	: 90 % max. (None condensing)
<b>Installation</b>	: Fixed installation
<b>Overvoltage Category</b>	: II
<b>Pollution Degree</b>	: II, office or workplace, none conductive pollution
<b>Operating Conditions</b>	: Continuous
<b>Supply Voltage and Power</b>	: 230V ~ (±15%) 50/60 Hz. 4VA 115V ~ (±15%) 50/60 Hz. 4VA 24V ~ (±15%) 50/60 Hz. 4VA
<b>Temperature Sensor Inputs</b>	: TC, RTD
<b>Thermocouple Input Types</b>	: J, K, R, S (IEC584.1)(ITS90)
<b>Thermoresistance Input Type</b>	: PT-100. (IEC751)(ITS90)
<b>Accuracy</b>	: 1% of full scale for Thermocouple and Thermoresistance
<b>Cold Junction Compensation</b>	: Automatically ± 0.1°C/1°C.
<b>Line Compensation</b>	: Maximum 10 .
<b>Sensor Break Protection</b>	: Upscale
<b>Sampling Cycle</b>	: 3 samples per second
<b>Resolution of Set Point</b>	: ± 0.2% of full scale
<b>Accuracy of Set Point</b>	: ±1% of full scale
<b>Control Forms</b>	: ON / OFF , Time Proportional
<b>Relay Output</b>	: 5A@250V ~ (Electrical Life : 100.000 Operation (Full Load))
<b>SSR Driver Output</b>	: Maximum 50mA, Maximum 18V ===
<b>Display</b>	: 8 mm Green 4 digits LED indicator
<b>Led Indicators</b>	: PWR (Green) , OUT (Red)
<b>Approvals</b>	: CE , ENEC

## 7. Other Informations

### Manufacturer Information:

Emko Elektronik Sanayi ve Ticaret A.Ş.  
Demirtaş Organize Sanayi Bölgesi Karanfil Sk. No:6 16369  
BURSA/TURKEY

Phone : +90 224 261 1900  
Fax : +90 224 261 1912

### Repair and Maintenance Service Information:

Emko Elektronik Sanayi ve Ticaret A.Ş.  
Demirtaş Organize Sanayi Bölgesi Karanfil Sk. No:6 16369  
BURSA/TURKEY

Phone : +90 224 261 1900  
Fax : +90 224 261 1912



Thank you very much for your preference to use Emko Elektronik Products.

[www.emkoelektronik.com.tr](http://www.emkoelektronik.com.tr)