

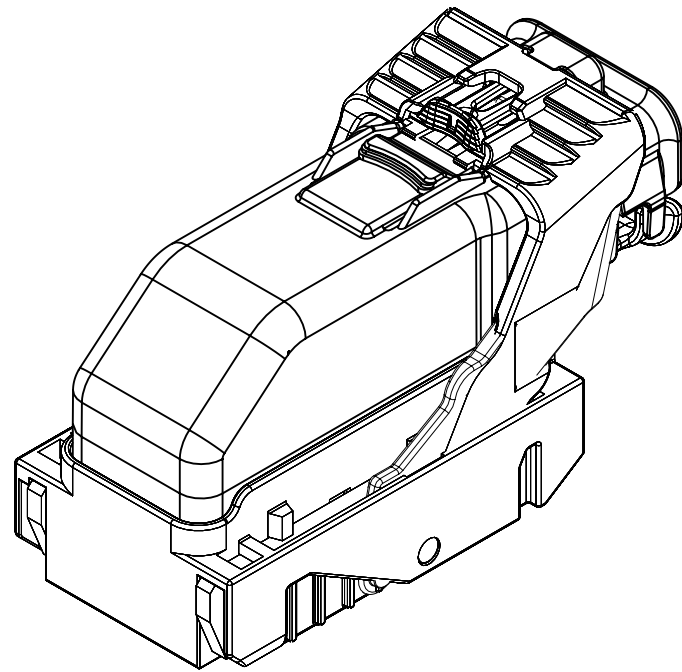

INDEX	
PAGE TITLE	PAGE
TITLE BLOCK	1
REVISION BLOCK	2
PART BLOCK	3
KPC BLOCK	4
COMPONENT TABLE	5
NOTES	6
NOTES	7
WIRE DRESS PACKAGING DIMENSIONS	8
LOCATION AND PACKAGING DIMENSIONS REFERENCING INTERFACE DATUMS B & C	9
LOCATION AND PACKAGING DIMENSIONS REFERENCING INTERFACE DATUM A	10
KEY ID REF - WIRE DRESS OPTION 0	11
KEY ID REF - WIRE DRESS OPTION 9	12
CIRCUIT CONFIGURATIONS	13
CIRCUIT CONFIGURATIONS	14
COMPONENT CONNECTOR INTERFACE	15
COMPONENT CONNECTOR INTERFACE	16
COMPONENT CONNECTOR INTERFACE	17
COMPONENT CONNECTOR INTERFACE	18
COMPONENT CONNECTOR INTERFACE	19
COMPONENT CONNECTOR INTERFACE	20
COMPONENT CONNECTOR INTERFACE	21



ISO VIEW

	<p>UNLESS OTHERWISE SPECIFIED: THIS DOCUMENT IS IN ACCORDANCE WITH ASME Y14.5M-1994 AS AMMENDED BY THE GM GLOBAL DIMENSIONING AND TOLERANCING ADDENDUM-1997. ALL GEOMETRIC TOLERANCES AND RELATED DATUMS APPLY RFS. RULE #1 (PERFECT FORM AT MMC) DOES NOT APPLY WHEN A RELATIONSHIP BETWEEN FEATURES IS ESTABLISHED BY ORIENTATION OR LOCATION TOLERANCES. SEPARATE POSITION CALLOUTS MAY BE GAGED SEPARATELY REGARDLESS OF DATUM REFERENCES.</p>			DATE						
	 CHANGE RESTRICTED NO MANUAL CHANGES	REFERENCE 12H (MOLEX AUTOMOTIVE)	DRAFTER J SZYMKOWSKI APVD1 D PFAFFINGER APVD2 B BURT APVD3 APVD4 APVD5	22DE05 22DE05 22DE05 						
DO NOT SCALE	DRAWING NAME HARNESS CONN ASM 66/73/80 CKTS									
METRIC DIMENSIONS SHOWN IN MILLIMETERS UNLESS OTHERWISE SPECIFIED	DRAWING NUMBER 12642695		DWG STATUS <table border="1"> <tr> <th>ST</th> <th>REV</th> <th>PD1</th> </tr> <tr> <td>R</td> <td>002</td> <td></td> </tr> </table>		ST	REV	PD1	R	002	
ST	REV	PD1								
R	002									
			PAGE NUMBER 1 OF 21							

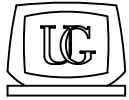
PAGE	DWG STATUS					REVISION HISTORY	AUTH	DR	CK	ENG
	DATE	ST	REV	CHG	PDI					
	19DE11	R	001			RELEASED TO PRODUCTION AT DLS A	CRMRJB	SC	MRO	GF
3	08MY15	R	002	A		REORDERED PART BLOCK AND ADDED MASS CORRECTED P/N TYPO FROM 12562676 TO 12582676				
3, 5		R	002	B		ADDED 12659312, 12659313, 12653574 AND 12653575				
6		R	002	C		REMOVED NOTE 1 . D . 3 . C				
20		R	002	D		DIM 125 WAS 3.25 DIM 131 WAS 5.5	CRMRJD	DFK	MRO	GF

PAGE	DWG STATUS					REVISION HISTORY	AUTH	DR	CK	ENG
	DATE	ST	REV	CHG	PDI					

KEY PRODUCT CHARACTERISTICS
(IN ACCORDANCE WITH QN 1805 OR ON 1050)



SAFETY/COMPLIANCE

TOTAL ON
DRAWING

5



FIT/FUNCTION

LAST NO.
USED

5

NO	TYPE	DESCRIPTION	RATIONALE	PAGE/ZONE
1	F/F	32.68	IMPROVE CONNECTOR SYSTEM MATING	15
2	F/F	29.00	INSURE PROPER RELEASE OF LEVER	15
3	F/F	15.25	INSURE FINAL MATE POSITION	16
5	F/F	POSITIONAL TOLERANCE (2 PLACES)	INSURE CONNECTOR SYSTEM MATEABILITY	19



PAGE TITLE
KPC BLOCK

DRAWING NUMBER

12642695

DWG STATUS

ST	REV	PD1
----	-----	-----

R	002	
---	-----	--

PAGE NUMBER

4 OF 21

LINE	MFG.	MFG. P/N	GM P/N	EFFECTIVE DATE	APPLICABLE COMPONENTS	KEY OPTION	WIRE DRESS OPTION	KEY CONFIG.	COLOR	STATUS
					DESCRIPTION					
-										
1	MOLEX	34565-0003	12582676	02JN03	MX123 DRESS COVER 66/73/80 CKT	N/A	N/A	N/A	BLACK	AVAILABLE
2	MOLEX	34822-0013	12642692	01SP13	MX123 HRNS CONN ASSY 66 CKT	A	0	1458	BLACK	AVAILABLE
3	MOLEX	34822-0033	12659312	01SP13	MX123 HRNS CONN ASSY 66 CKT	C	0	2467	BLUE	AVAILABLE
4	MOLEX	34822-0023	12642693	01SP13	MX123 HRNS CONN ASSY 66 CKT	A	9	1458	BLACK	AVAILABLE
5	MOLEX	34822-0043	12659313	01SP13	MX123 HRNS CONN ASSY 66 CKT	C	9	2467	BLUE	AVAILABLE
6	MOLEX	34566-0103	12582677	11JN04	MX123 HRNS CONN ASSY 73 CKT	A	0	1458	BLACK	AVAILABLE
7	MOLEX	34566-0203	12582678	11JN04	MX123 HRNS CONN ASSY 73 CKT	B	0	1468	ST GRAY	AVAILABLE
8	MOLEX	34566-0303	12615654	09AP08	MX123 HRNS CONN ASSY 73 CKT	C	0	2467	BLUE	AVAILABLE
9	MOLEX	34566-0403	12647268	T.B.D	MX123 HRNS CONN ASSY 73 CKT	D	0	2367	BROWN	NOT ACTIVE
10	MOLEX	34566-0503	AMJ28633	T.B.D	MX123 HRNS CONN ASSY 73 CKT	E	0	2468	GREEN	NOT ACTIVE
11	MOLEX	34566-0603	12653574	05DC14	MX123 HRNS CONN ASSY 73 CKT	F	0	1357	NATURAL	AVAILABLE
12	MOLEX	34566-0703	12588057	09AP08	MX123 HRNS CONN ASSY 80 CKT	G	0	1358	BLUE	AVAILABLE
13	MOLEX	34566-0803	12588058	11JN04	MX123 HRNS CONN ASSY 80 CKT	H	0	2458	ST GRAY	AVAILABLE
14	MOLEX	34566-0903	12615656	T.B.D	MX123 HRNS CONN ASSY 80 CKT	J	0	2457	BLACK	NOT ACTIVE
15	MOLEX	34566-1003	AMJ28595	T.B.D	MX123 HRNS CONN ASSY 80 CKT	K	0	2357	BROWN	NOT ACTIVE
16	MOLEX	34566-1103	AMJ29057	T.B.D	MX123 HRNS CONN ASSY 80 CKT	L	0	2368	GREEN	NOT ACTIVE
17	MOLEX	34566-1203	AMJ28669	T.B.D	MX123 HRNS CONN ASSY 80 CKT	M	0	2358	NATURAL	NOT ACTIVE
18	MOLEX	34566-1303	12603596	11JN04	MX123 HRNS CONN ASSY 73 CKT	A	9	1458	BLACK	AVAILABLE
19	MOLEX	34566-1403	12603597	11JN04	MX123 HRNS CONN ASSY 73 CKT	B	9	1468	ST GRAY	AVAILABLE
20	MOLEX	34566-1503	12615655	09AP08	MX123 HRNS CONN ASSY 73 CKT	C	9	2467	BLUE	AVAILABLE
21	MOLEX	34566-1603	12647269	T.B.D	MX123 HRNS CONN ASSY 73 CKT	D	9	2367	BROWN	NOT ACTIVE
22	MOLEX	34566-1703	AMJ28698	T.B.D	MX123 HRNS CONN ASSY 73 CKT	E	9	2468	GREEN	NOT ACTIVE
23	MOLEX	34566-1803	12653575	05DC14	MX123 HRNS CONN ASSY 73 CKT	F	9	1357	NATURAL	AVAILABLE
24	MOLEX	34566-1903	12603598	09AP08	MX123 HRNS CONN ASSY 80 CKT	G	9	1358	BLUE	AVAILABLE
25	MOLEX	34566-2003	12603599	11JN04	MX123 HRNS CONN ASSY 80 CKT	H	9	2458	ST GRAY	AVAILABLE
26	MOLEX	34566-2103	12615657	T.B.D	MX123 HRNS CONN ASSY 80 CKT	J	9	2457	BLACK	NOT ACTIVE
27	MOLEX	34566-2203	AMJ29117	T.B.D	MX123 HRNS CONN ASSY 80 CKT	K	9	2357	BROWN	NOT ACTIVE
28	MOLEX	34566-2303	AMJ29136	T.B.D	MX123 HRNS CONN ASSY 80 CKT	L	9	2368	GREEN	NOT ACTIVE
29	MOLEX	34566-2403	AMJ29214	T.B.D	MX123 HRNS CONN ASSY 80 CKT	M	9	2358	NATURAL	NOT ACTIVE
30	MOLEX	34736-2002	12642697	01AU10	MX64 RCPT TERM Ag 18/20 GAGE B (RIGHT PAYOFF)	N/A	N/A	N/A	N/A	AVAILABLE
31	MOLEX	34736-2001	12642696	01AU10	MX64 RCPT TERM Ag 22 GAGE B (RIGHT PAYOFF)	N/A	N/A	N/A	N/A	AVAILABLE
32	MOLEX	34586-0001	T.B.D.	11JN04	MX123 0.64MM GROMMET PLUG	N/A	N/A	N/A	NATURAL	AVAILABLE
33	YAZAKI	7116-4150-02	12588066	02JN03	2.8mm YESC SEALED FEMALE TERMINAL TIN 20/22 GAGE (CABLE RANGE 0.30mm-0.60mm)	N/A	N/A	N/A	N/A	NOT ACTIVE
34	YAZAKI	7116-4151-02	12588067	02JN03	2.8mm YESC SEALED FEMALE TERMINAL TIN 16/18 GAGE (CABLE RANGE 0.75mm-1.40mm)	N/A	N/A	N/A	N/A	NOT ACTIVE
35	YAZAKI	7116-4152-02	12582685	02JN03	2.8mm YESC SEALED FEMALE TERMINAL TIN 14 GAGE (CABLE RANGE 1.50mm-2.50mm)	N/A	N/A	N/A	N/A	AVAILABLE
36	YAZAKI	7158-3111-60	12588068	02JN03	2.8mm CABLE SEAL (wire O.D. range 1.20mm-1.90mm)	N/A	N/A	N/A	GREEN	NOT ACTIVE
37	YAZAKI	7158-3112-70	12588069	02JN03	2.8mm CABLE SEAL (wire O.D. range 1.80mm-2.30mm)	N/A	N/A	N/A	YELLOW	NOT ACTIVE
38	YAZAKI	7158-3113-40	12582686	02JN03	2.8mm CABLE SEAL (wire O.D. range 2.18mm-3.00mm)	N/A	N/A	N/A	WHITE	AVAILABLE
39	YAZAKI	7158-3114-90	T.B.D	02JN03	2.8mm YESC CAVITY PLUG	N/A	N/A	N/A	BLUE	AVAILABLE
40	MOLEX	63811-4200	XX019825	02JN03	MX64 TERM HAND CRIMP TOOL	N/A	N/A	N/A	N/A	AVAILABLE
41	MOLEX	63813-1400	XX019826	02JN03	MX64 TERM SERVICE TOOL	N/A	N/A	N/A	N/A	AVAILABLE
42	MOLEX	63865-8000	XX019827	02JN03	MX64 CRIMP APPLICATOR with TOOL KIT 18/20 GAGE PAYOFF DIRECTION D (left payoff) (contact Molex for payoff detail)	N/A	N/A	N/A	N/A	AVAILABLE
43	MOLEX	63865-8070	XX019828	02JN03	MX64 APPLICATOR TOOL KIT 18/20 GAGE	N/A	N/A	N/A	N/A	AVAILABLE
44	MOLEX	63865-8100	XX019829	02JN03	MX64 CRIMP APPLICATOR with TOOL KIT 22 GAGE PAYOFF DIRECTION D (left payoff) (contact Molex for payoff detail)	N/A	N/A	N/A	N/A	AVAILABLE
45	MOLEX	63865-8170	XX019830	02JN03	MX64 APPLICATOR TOOL KIT 22 GAGE	N/A	N/A	N/A	N/A	AVAILABLE
46	SPX	J35616-64	T.B.D.	02JN03	0.64mm PROBE TOOL (for rcpt)	N/A	N/A	N/A	N/A	AVAILABLE
47	SPX	J35616-64A	T.B.D.	02JN03	0.64mm PROBE TOOL WITH EXT (for rcpt)	N/A	N/A	N/A	N/A	AVAILABLE
48	SPX	J35616-65	T.B.D.	02JN03	0.64mm PROBE TOOL WITH EXT (for pin)	N/A	N/A	N/A	N/A	AVAILABLE
49	SPX	J35616-4A	T.B.D.	02JN03	2.8mm PROBE TOOL (for rcpt)	N/A	N/A	N/A	N/A	AVAILABLE
50	YAZAKI	X39899-J374	12094430	02JN03	2.8mm TERM SERVICE TOOL	N/A	N/A	N/A	N/A	AVAILABLE

002B

* - MX123 DRESS COVER 73/80/66 CKT MATES TO ANY MX123 HARN CONN ASSY SHOWN ON TABLE ABOVE

	PAGE TITLE	DRAWING NUMBER	DWG STATUS			PAGE NUMBER
	COMPONENT TABLE	12642695	ST	REV	PDI	5 OF 21
			R	002		

NOTES: UNLESS OTHERWISE SPECIFIED

1. MATERIAL FOR INTERFACE:

- A. RESIN:
 - 1. 30% G.F. PBT; 20% MAX. (BY WEIGHT) REGRIND.
 - 2. MATING CONNECTOR INTERFACE PART COLOR MUST BE SAME AS MATCHING KEYED HARNESS CONNECTOR ASSEMBLY.
 - 3. MUST BE VALIDATED FOR INDIVIDUAL DEVICE APPLICATION REQUIREMENTS.
- B. 0.64MM PINS:
 - 1. BASE MATERIAL: COPPER ALLOY; CONDUCTIVITY >= 28% IACS AT 20°C; TENSILE STRENGTH >= 635 N/mm²; SURFACE ROUGHNESS R_a 6 MAX.
 - 2. PLATING FINISH: SILVER (Ag). PLATING TO BE 1.9-3.3 μm ELECTRODEPOSITED SEMI-BRIGHT SILVER OVER 1.25-2.25 μm DUCTILE SULPHAMATE NICKEL PER NOTE 1(D).
 - 3. ANTI-TARNISH: SYNTHETIC HYDROCARBON CONTACT SURFACE FINISH OR EQUIVALENT APPLIED WITHOUT VOID TO CONTACT AREA (MIN 3.7mm FROM PIN TIP).
- C. 2.8MM BLADE:
 - 1. BASE MATERIAL: COPPER ALLOY; CONDUCTIVITY >= 28% IACS AT 20°C; TENSILE STRENGTH >= 350 N/mm²; SURFACE ROUGHNESS R_a 6 MAX.
 - 2. PLATING FINISH: TIN. PLATING TO BE 2.5-5.0 μm ELECTRODEPOSITED TIN, MATTE FINISH OVER 1.25-2.5 μm DUCTILE SULPHAMATE NICKEL PER NOTE 1(D).
- D. PLATING REQUIREMENTS:
 - 1. SILVER PLATING
 - a. 99.5% PURE SEMI-BRIGHT WITH NO ORGANIC BRIGHTNERS OR CHROMATES.
 - 2. NICKEL PLATING
 - a. ELECTRODEPOSITED DUCTILE SULFAMATE NICKEL WITH A NON-BRIGHTENED FINISH. NO ORGANIC OR BRIGHTENING AGENTS SHALL BE ALLOWED.
 - b. SHALL ONLY BE USED AS AN UNDERLYING PLATING AND MAY NOT BE USED AS AN ELECTRICAL CONTACT SURFACE PLATING.
 - c. SHALL BE NODULE FREE WHEN VIEWED AT 10X MAGNIFICATION IN MEASURED IN CONTACT SURFACE AREA PLUS 0.5MM PERIMETER AROUND THE CONTACT SURFACE AREA.
 - d. ALL PLATINGS SHALL HAVE A 1.0% MAXIMUM BY WEIGHT IMPURITIES. IMPURITIES ARE DEFINED AS ALL ELEMENTS NOT THE PRIMARY PLATING OR HARDENING AGENT IF APPLICABLE, AS DETERMINED BY WET CHEMICAL ANALYSIS OR AUGER METHOD. NO SINGLE IMPURITY SHALL EXCEED 0.1% MAXIMUM BY WEIGHT.
 - 3. TESTING
 - a. THICKNESS TO BE MEASURED IN CONTACT SURFACE AREA PLUS 0.5MM PERIMETER AROUND THE CONTACT SURFACE AREA AS DESIGNATED IN THE DRAWING. THICKNESS SHALL BE DETERMINED BY METHOD OF X-RAY (XRF).
 - b. PLATING ADHESION SHALL BE TESTED BY A BEND TEST FOR ALL METALS. THE TEST SAMPLE SHALL BE BENT 90 DEGREES TO DETERMINE DEPOSIT ADHESION. TESTING SHALL BE COMPLETED IN ACCORDANCE WITH ASTM SPEC B571.

2. DESIGN - GENERAL:

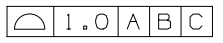
- A. THIS IS A 100% CAD GENERATED PART. THE CAD MATHEMATICAL DATA IS THE MASTER FOR THIS PART. FOR DIMENSIONAL OR ANY INFORMATION NOT SHOWN ON THIS DRAWING, ANALYZE THE CAD MODEL.
- B. TOLERANCES:
 - 1. LINEAR
 - 0.X ± 0.30
 - 0.XX ± 0.10
 - 0.XXX ± 0.10
 - 2. ANGULAR X° ± 3°
 - 3. 
- C. MINIMUM WALL THICKNESS REQUIRED: 1.3mm.
- D. CORNERS SHOWN AS SHARP TO BE R 0.2 MAX.
- E. LETTERING SHALL BE 0.15 MAX RAISED IN 0.20 MAX RECESS PAD. THIS INCLUDES MATERIAL CODE, RECYCLING CODE, CAVITY ID AND DATE CODE.
- F-1. PARTS MUST BE FREE OF DISCOLORATION, SALT RESIDUE AND OTHER IMPERFECTIONS THAT AFFECT FIT OR FUNCTION.
- F-2. SCRATCHES OR DENTS NOT TO EXCEED 0.013mm IN DEPTH.
- G. FOLLOWING PRODUCTION CODES TO BE PERMANENTLY MARKED & HUMAN READABLE TO A LETTER HEIGHT OF 1.5 ± 0.5MM X 0.3 MAX DEEP
 - 1. MATERIAL #: XXXXX-XXXX
 - 2. DATE CODE: JJYY (JULIAN DAY, LAST DIGIT OF YEAR)
 - 3. INSPECTION MACHINE CODE + SERIAL #: X_XXXXX

3. DESIGN - MANUFACTURING:

- A. DRAFT TO BE WITHIN TOLERANCE.
- B. ALLOWABLE FLASH MAX 0.2 HIGH X MAX 0.13 THICK.
- C. ALLOWABLE PARTING LINE MISMATCH 0.2 MAX.
- D. EJECTOR PINS MARK TO BE FLUSH TO 0.25 MAX DEPRESSED.
- E. ALLOWABLE GATE VESTIGE FLUSH TO 0.25 MAX PROTRUSION.
- F. NO EXTERNAL MOLD RELEASE AGENT ALLOWED DURING MANUFACTURING.
- G. STEEL THAT FORMS THE INDICATED SURFACE MUST BE POLISHED WITH A DIAMOND FINISH (SPI A-2) OVER THE FULL PERIPHERY OF THE TOOL. SURFACE MUST HAVE NO MISMATCH.
- H. ANY PROCESS LUBRICANT REMAINING ON THE TERMINAL MUST NOT VARNISH OR DEGRADE IT'S ELECTRICAL PERFORMANCE UP TO A MAXIMUM CLASS AMBIENT TEMPERATURE PER SAE USCAR-2 FOR 1008 HOURS. PROCESS LUBRICANTS SHOULD BE APPROVED BY THE RESPONSIBLE ENGINEER.
- J. OPTIONAL FEATURES PROVIDED FOR AUTOMATION.
- K. PART MUST BE FREE FROM BURRS AND SHARP EDGES, WHICH MIGHT BE DETRIMENTAL TO SATISFACTORY ASSEMBLY, SAFE HANDLING OR FUNCTION OF PART.
- L. PARTS AS DELIVERED TO ASSEMBLY SHALL BE CLEAN AND FREE OF DEBRIS, RESIDUAL ABRASIVE MATERIAL AND CORROSION PRODUCTS ADVERESLY AFFECTING FUNCTION OR APPEARANCE.
- M. RESTRICTED AND REPORTABLE SUBSTANCES FOR PARTS PER GMW3059.

002C

	PAGE TITLE	DRAWING NUMBER	DWG STATUS			PAGE NUMBER	
	NOTES		12642695	ST	REV	PDI	6 OF 21
				R	002		

NOTES: UNLESS OTHERWISE SPECIFIED

4. SYSTEM REQUIREMENTS:

A. HARNESS CONNECTOR IS COMPATIBLE WITH THE FOLLOWING SAE WIRE SIZE NO'S:

- 14, MEETING SAE J1128
- 18, MEETING SAE J1128, MAX O.D. OF 2.06 MM
- 20, MEETING SAE J1128
- 22, MEETING SAE J1128, MIN O.D. OF 1.47 MM

B. CABLE TIE SPECIFICATIONS:

- 1. CABLE TIE:
 - TENSILE RATING: 220N / (50lbs) MIN
 - TIE LENGTH: 186mm MIN
 - TIE WIDTH: 4.75mm MAX
 - MATERIAL: NYLON
- 2. INSTALLATION:
 - CABLE TIE TENSION: 190N MIN
- 3. DRESSED WIRE BUNDLE PACKAGING: SEE FIG. 1

C. WHEN MATED WITH COMPONENT CONNECTOR INTERFACE AND/OR DRESS COVER, HARNESS CONNECTOR SYSTEM CONFORMS TO THE FOLLOWING:

- 1. SAE/USCAR-2, REV: 3 APRIL, 2001; CLASS 3
- 2. FIELD CORRELATED LIFE TEST, SAE/USCAR-20, NOV. 2001
- 3. GMW #3191 AUGUST 22, 2000 (DRAFT); TEMPERATURE CLASS 3, SEALING CLASS 1, VIBRATION CLASS 2
- 4. RESTRICTED AND REPORTABLE CHEMICALS PER GMW #3059, REV: D AUGUST 2002
- 5. TPA USER FORCES (FULLY POPULATED WITH TERMINALS)
 - a. REMOVAL FROM LOCK TO PRE-SET: <=120N

D. WIRE SPECIFICATIONS:

- 1. WIRE SURFACE MUST BE FREE OF SCRATCHES, GROOVES OR DENTS WHERE FUNCTIONAL

5. TERMINAL CURRENT RATINGS:

ALL TESTING DONE IN ACCORDANCE WITH USCAR-2 REV5 SECTION 5.3

A. MX64 RCPT TERM

- 1. MX64 RCPT TERM Ag 18/20 GAGE CRIMPED TO SAE WIRE SIZE NO.18 AND MATED TO MX123 0.64MM PIN: 11.3 AMPS
- 2. MX64 RCPT TERM Ag 22 GAGE CRIMPED TO SAE WIRE SIZE NO.22 AND MATED TO MX123 0.64MM PIN:8.5 AMPS

WIRE	CURRENT RATING			
	23°C	85°C	105°C	125°C
18AWG	11.3A	11.3A	9.5A	6.6A
20AWG	10.0A	10.0A	8.3A	5.7A
22AWG	8.6A	8.6A	7.1A	5.0A

B. 2.8MM RCPT TERM

- 1. 2.8MM RCPT TERM TIN 14 GAGE CRIMPED TO SAE WIRE SIZE NO.14 AND MATED TO MX123 2.8MM BLADE: 25.6 AMPS

6. CONTACT MOLEX AUTOMOTIVE FOR AVAILABLE CUSTOM PATTERNS OF CAVITIES OPEN FOR CIRCUITS



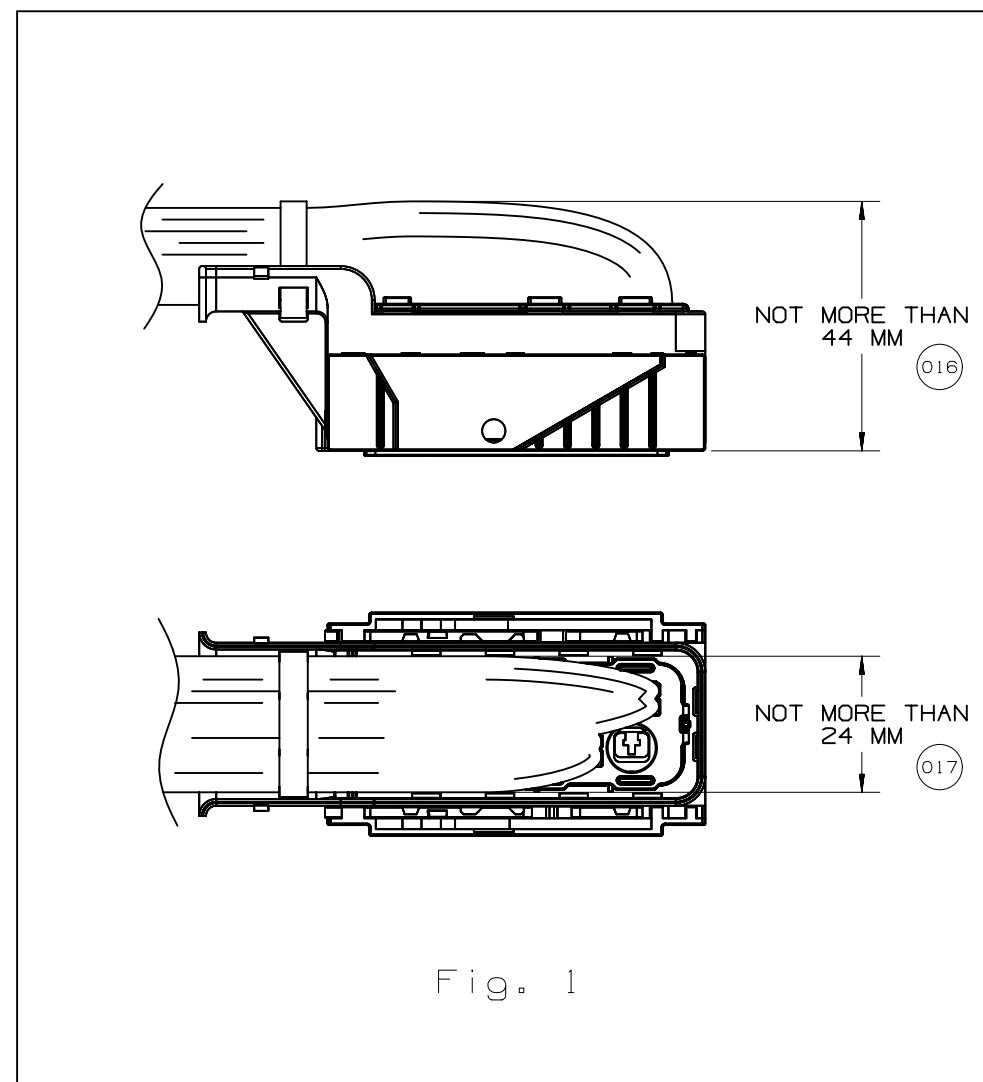
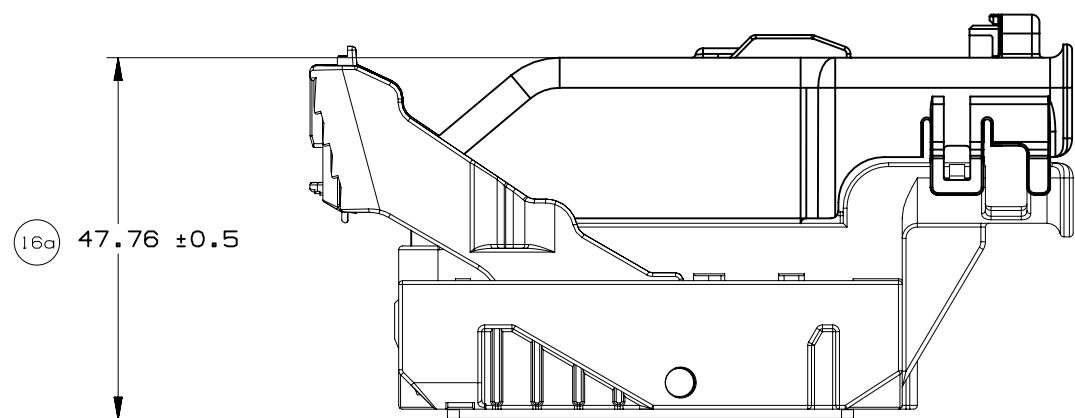

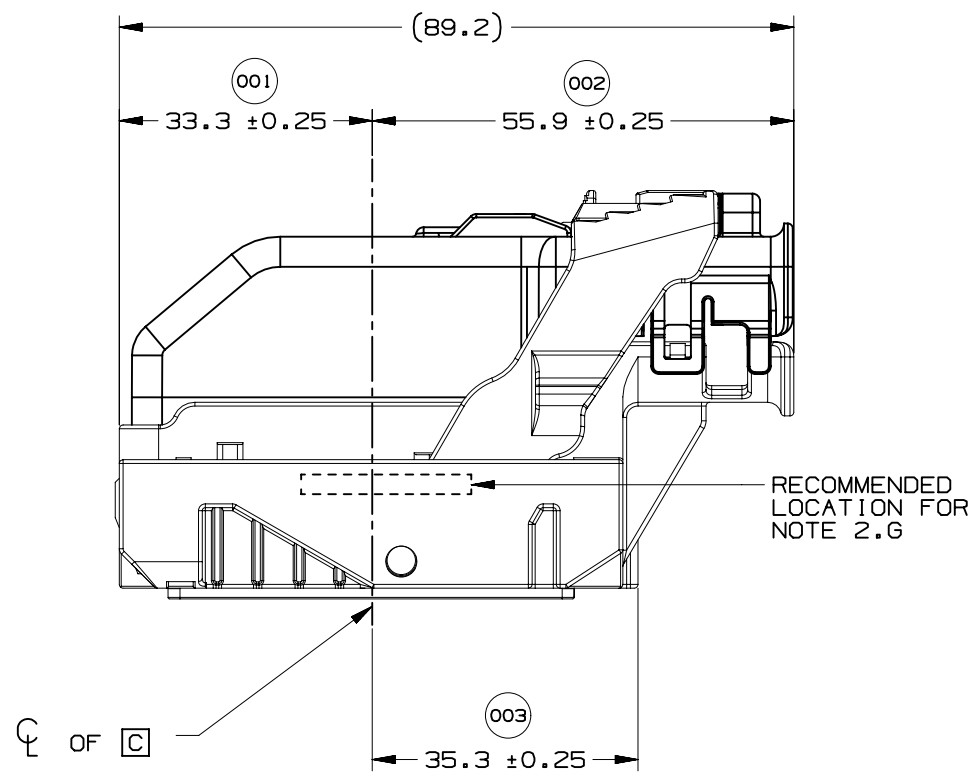

WIRE DRESS OPTION 0 SHOWN

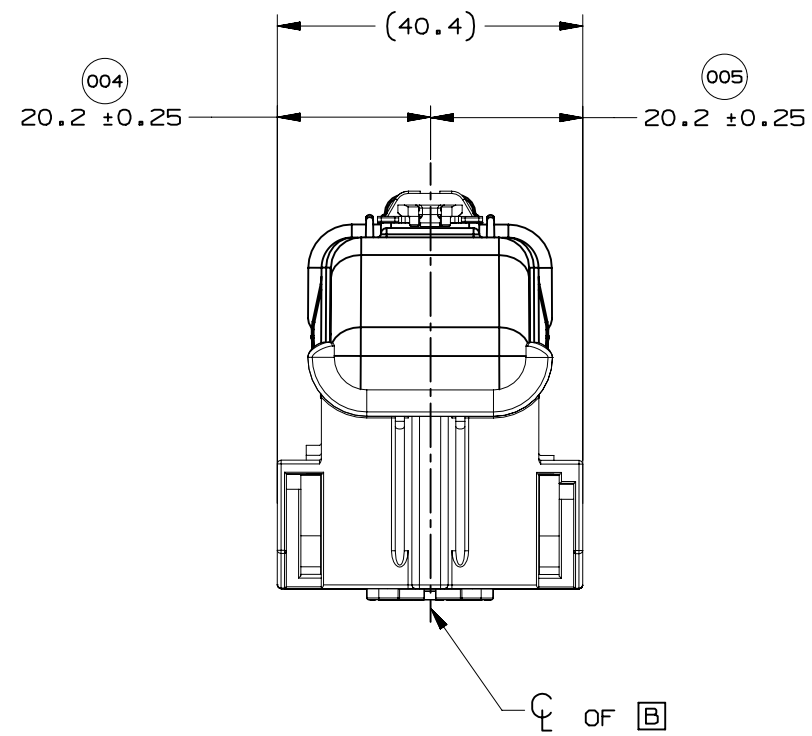

WIRE DRESS OPTION 0 SHOWN

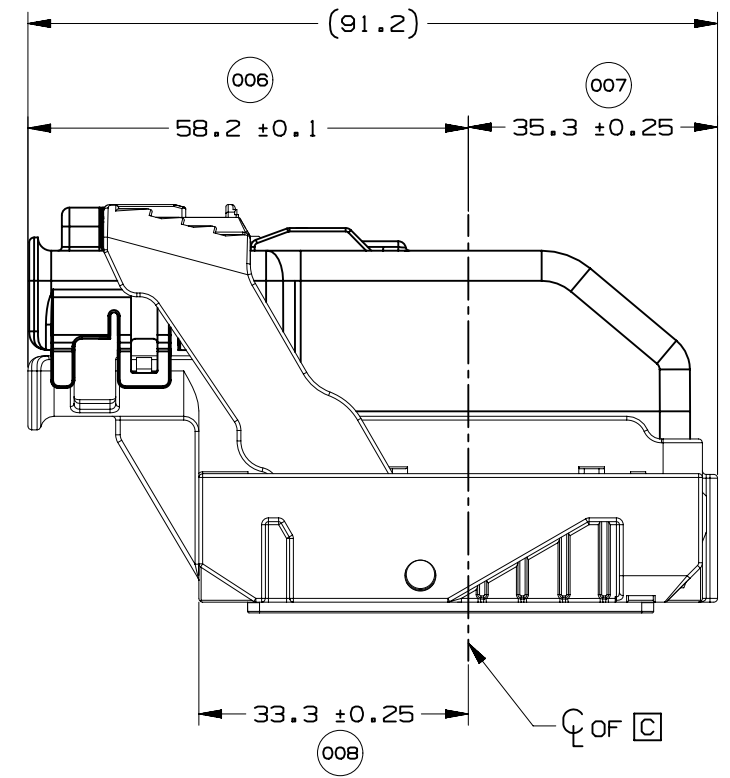

WIRE DRESS OPTION 9 SHOWN



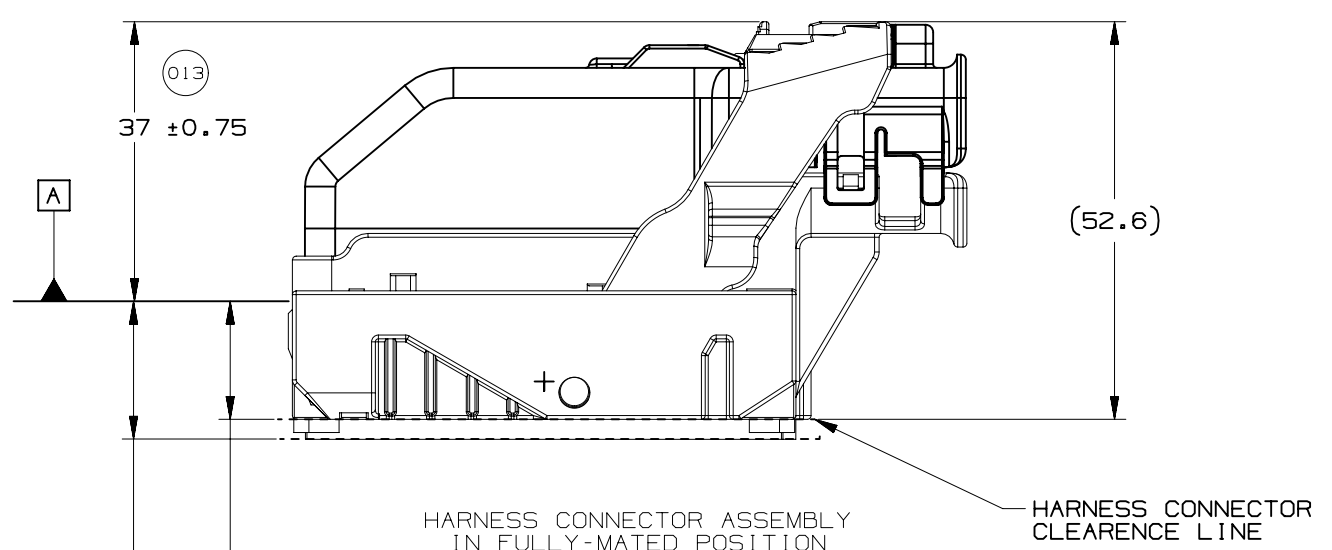
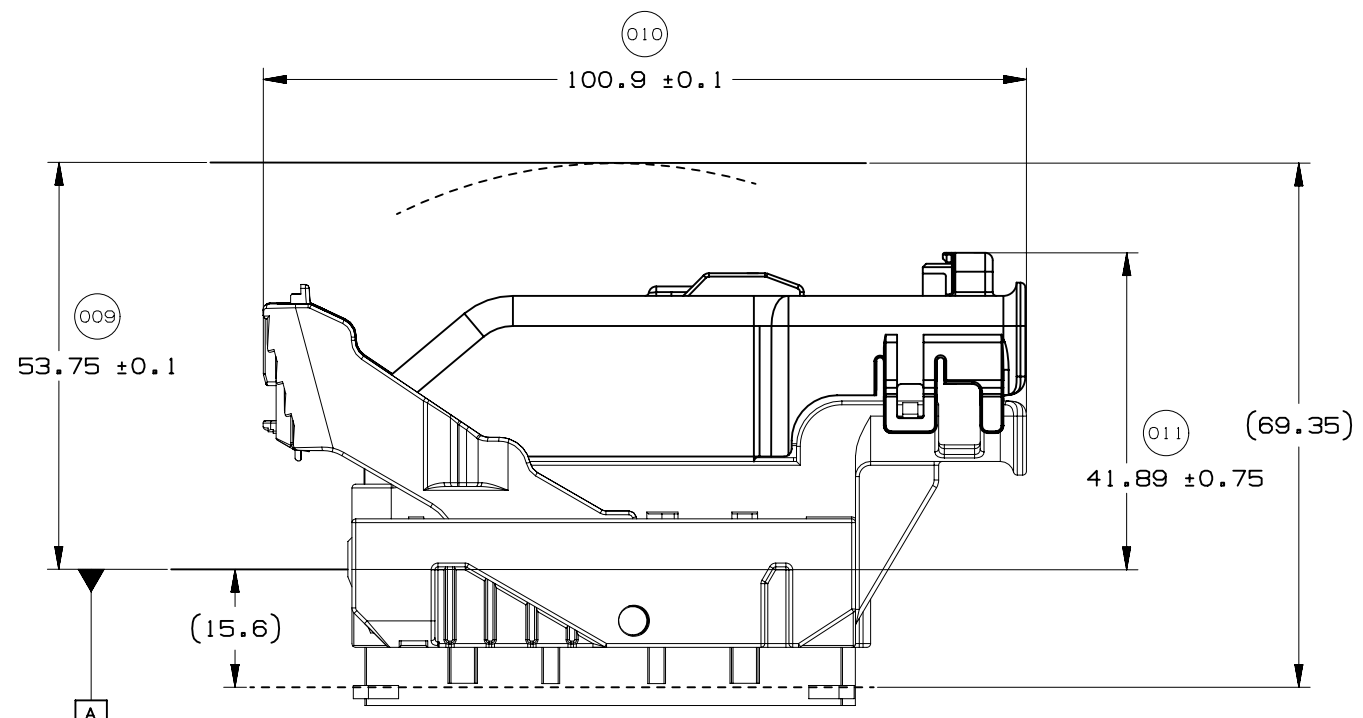
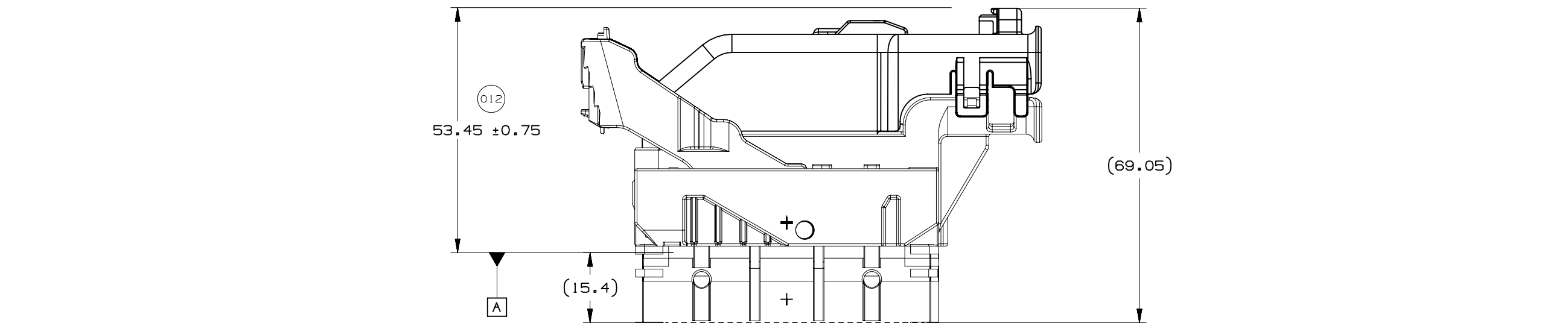

17.9 MIN. AT PAD LOCATION
 CLEARANCE REQUIRED
 FOR HARNESS CONNECTOR
 CONSTRUCTION BELOW THIS
 PLANE IS NOT CONTROLLED

015

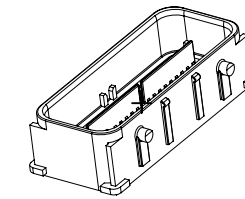
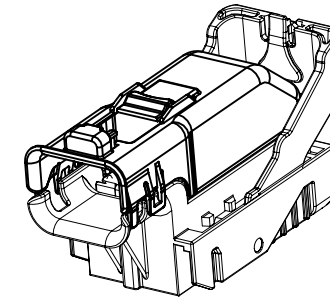
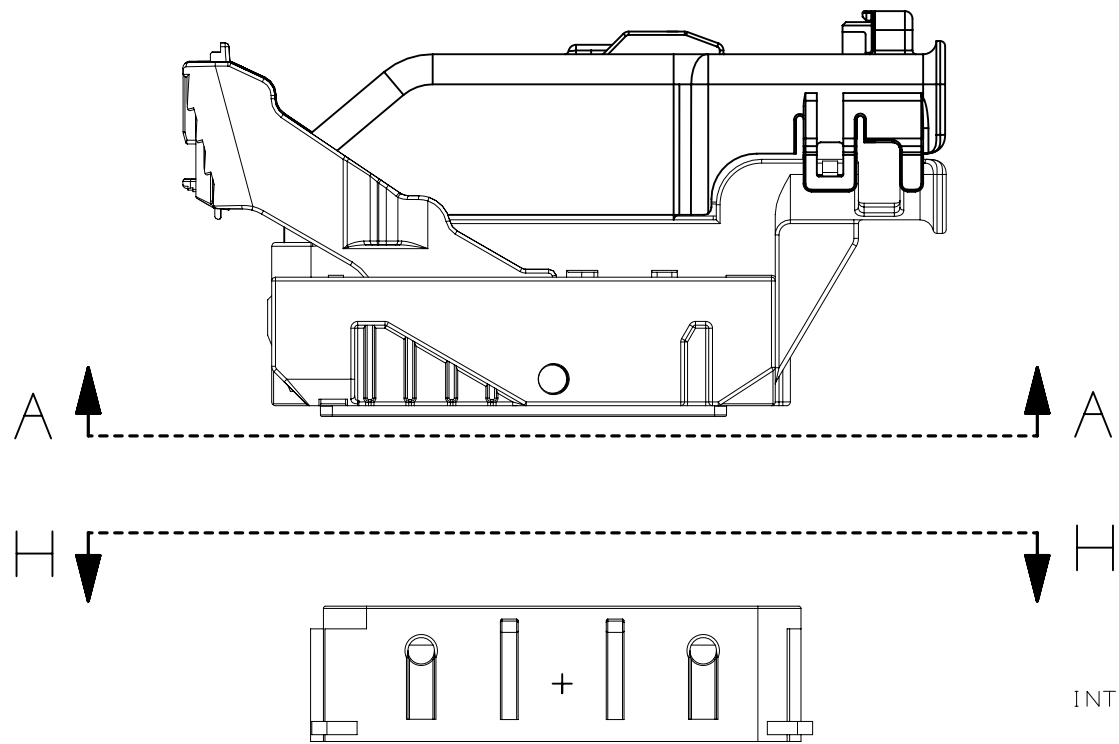

NOTE: REFERENCE THE COMPONENT TABLE FOR KEY OPTIONS AND CONFIGURATIONS

INTERFACE SIDE SHOWN ON ALL SECTION VIEWS

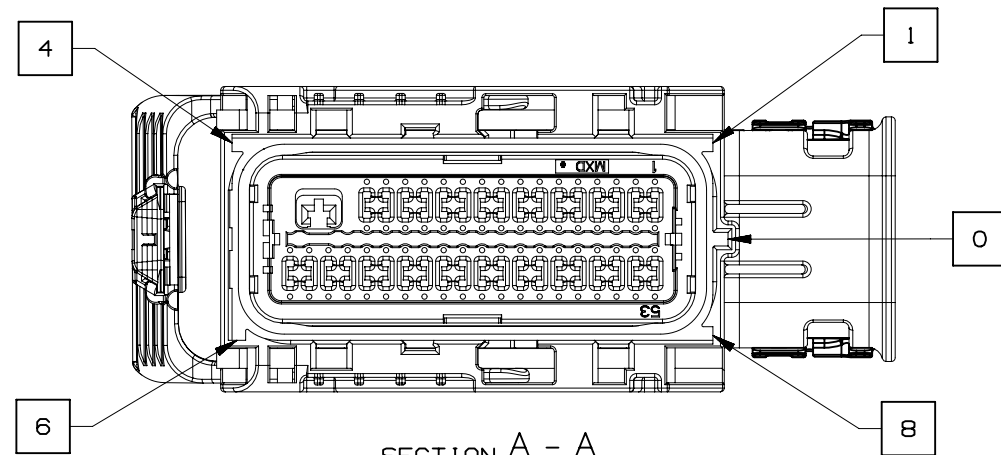

SECTION A - A
KEY OPTION B SHOWN

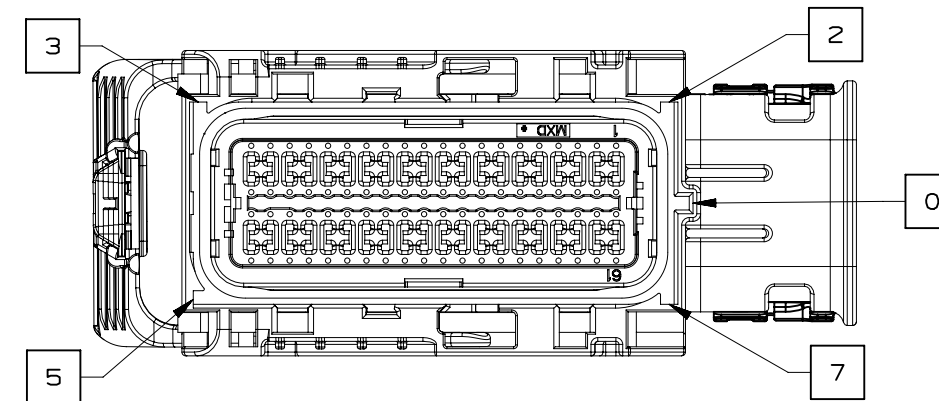

SECTION A - A
KEY OPTION K SHOWN

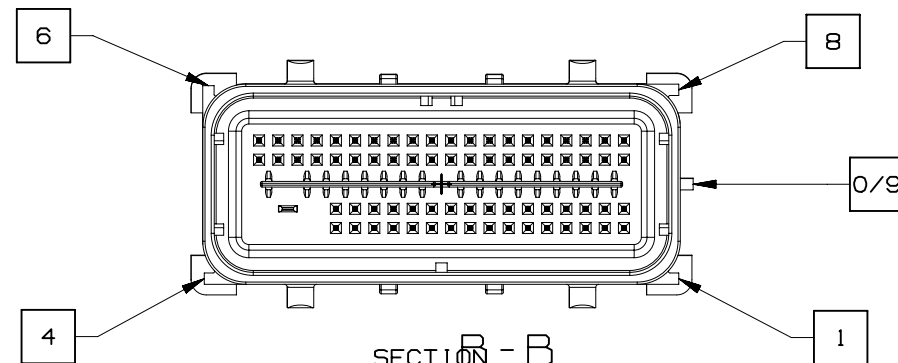

SECTION B - B
KEY OPTION B SHOWN

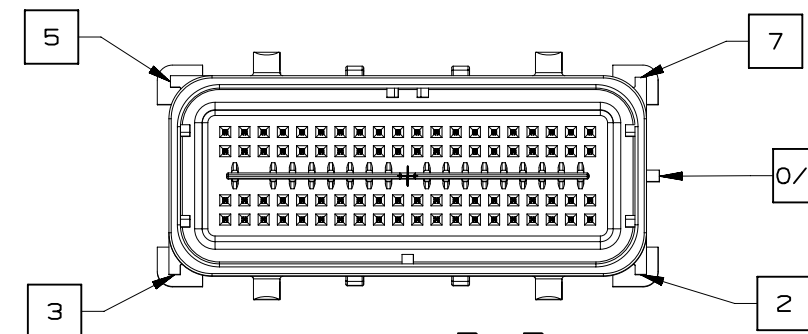

SECTION B - B
KEY OPTION K SHOWN



PAGE TITLE
KEY ID REF - WIRE DRESS OPTION 0

DRAWING NUMBER
12642695

DWG STATUS		
ST	REV	PD1
R	002	

PAGE NUMBER
11 OF 21

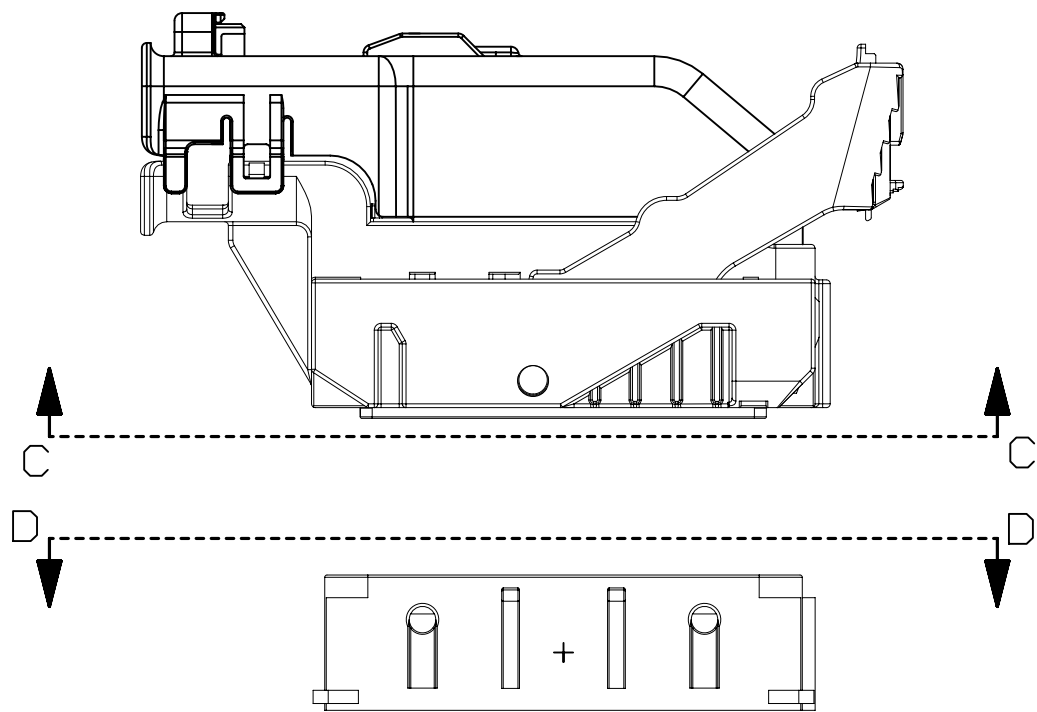

INTERFACE SIDE SHOWN ON ALL SECTION VIEWS

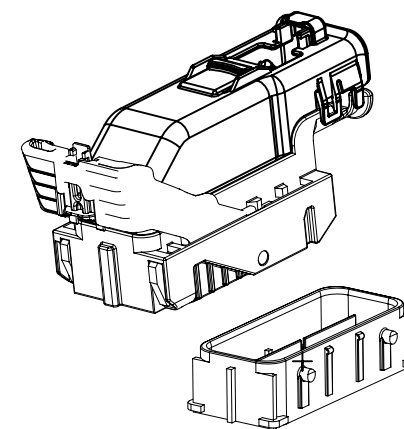

NOTE: REFERENCE THE COMPONENT TABLE FOR KEY OPTIONS AND CONFIGURATIONS

VIEW V

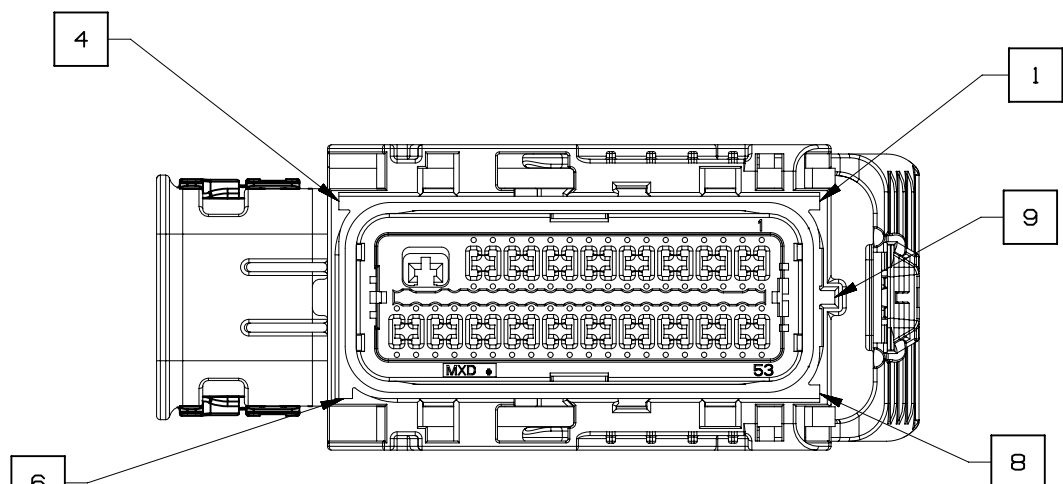

SECTION C-C
KEY OPTION B SHOWN

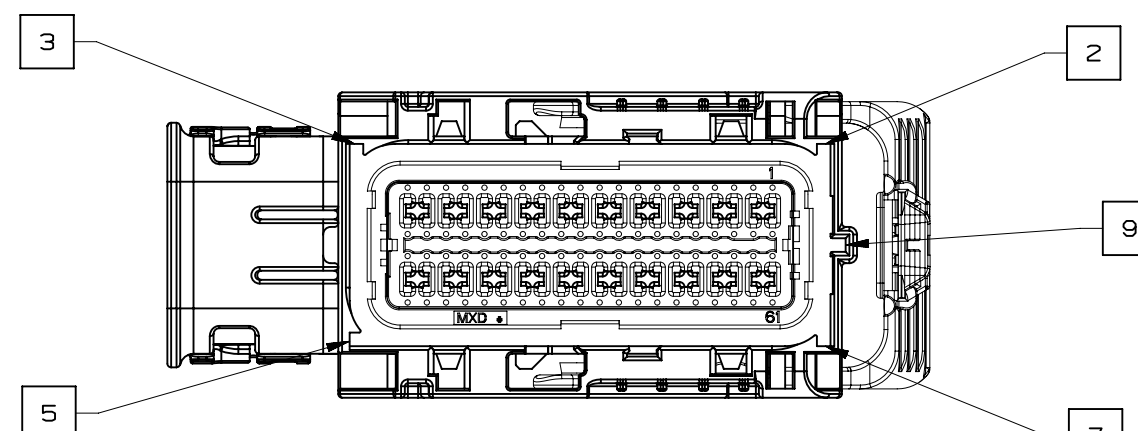

SECTION C-C
KEY OPTION K SHOWN

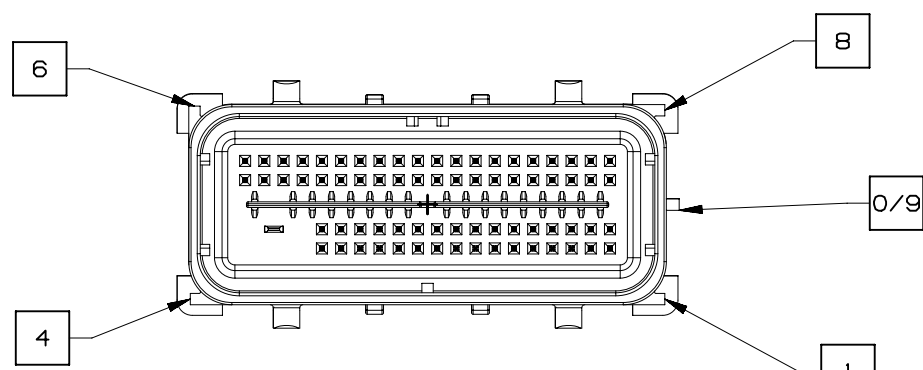

SECTION D-D
KEY OPTION B SHOWN

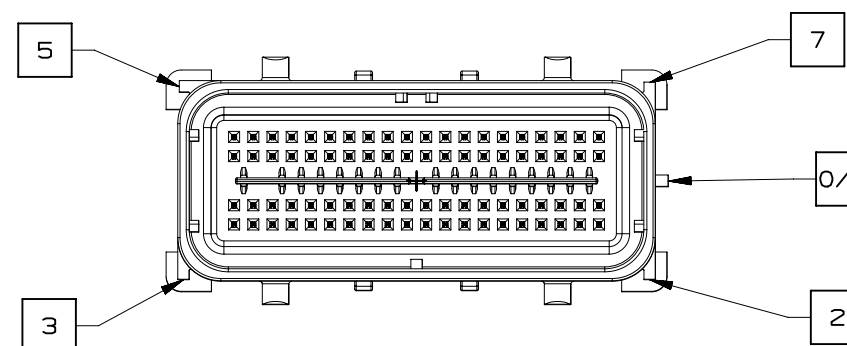

SECTION D-D
KEY OPTION K SHOWN



PAGE TITLE
KEY ID REF - WIRE DRESS OPTION 9

DRAWING NUMBER
12642695

DWG STATUS		
ST	REV	PD1
R	002	

PAGE NUMBER
12 OF 21

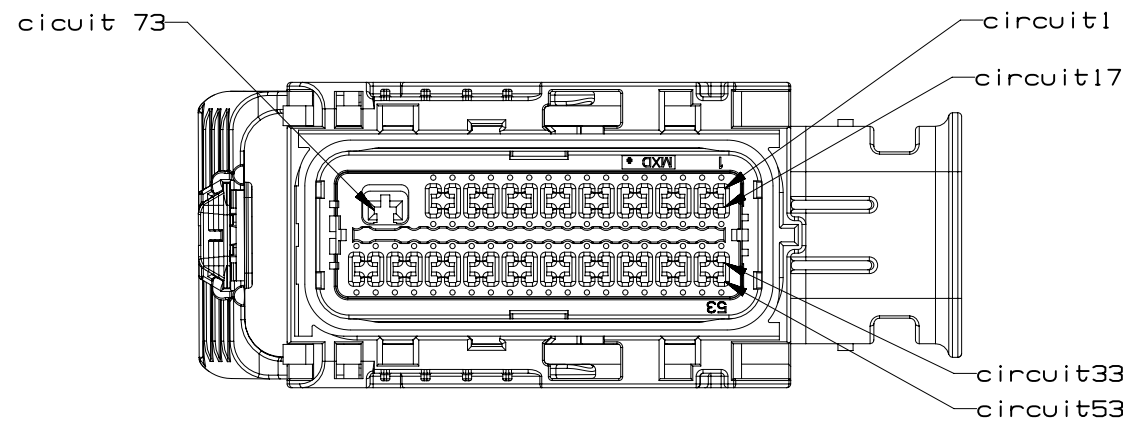

73 CKT HARNESS CONNECTOR ASSEMBLY
WIRE DRESS OPTION 0

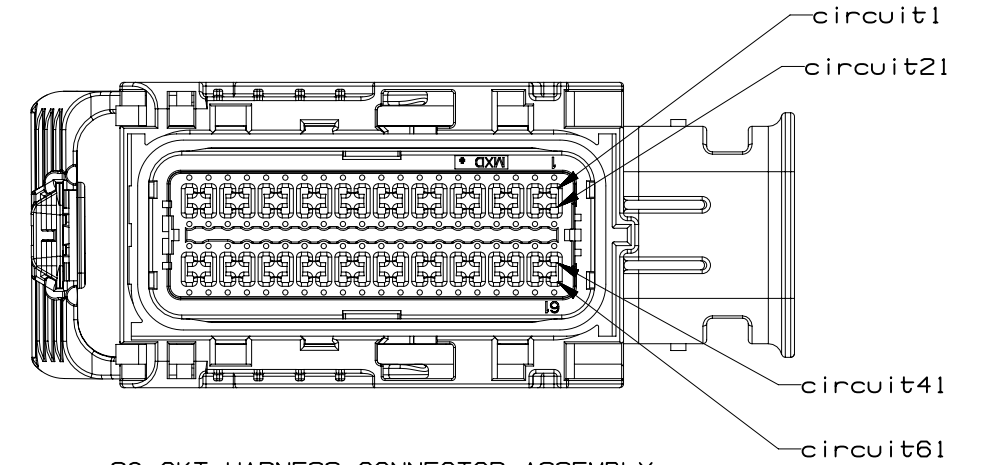

80 CKT HARNESS CONNECTOR ASSEMBLY
WIRE DRESS OPTION 0

INTERFACE SIDE SHOWN ON ALL VIEWS

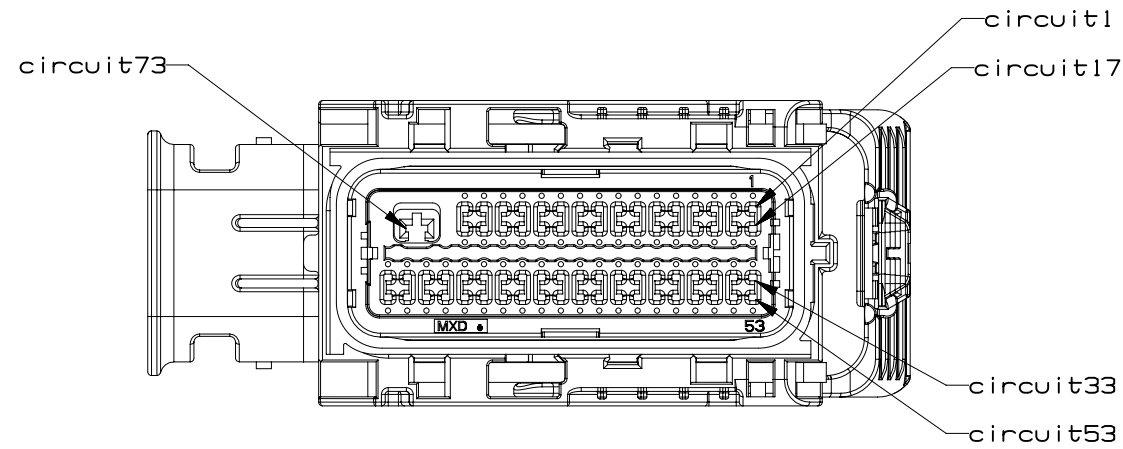

73 CKT HARNESS CONNECTOR ASSEMBLY
WIRE DRESS OPTION 9

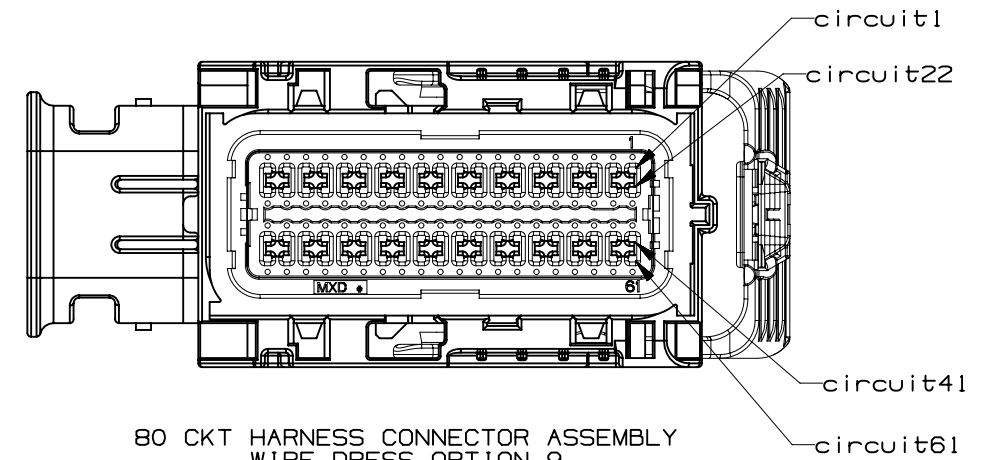

80 CKT HARNESS CONNECTOR ASSEMBLY
WIRE DRESS OPTION 9

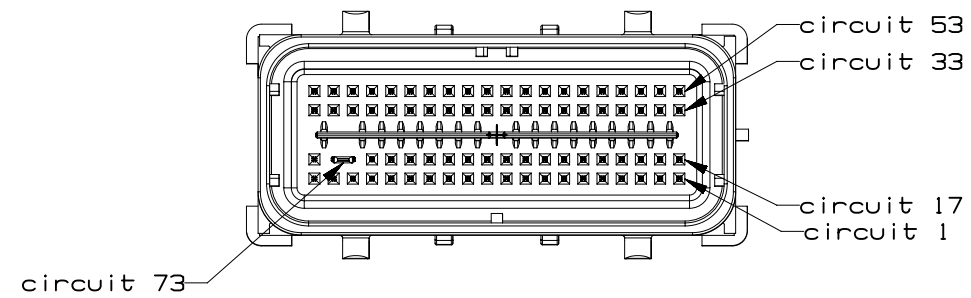

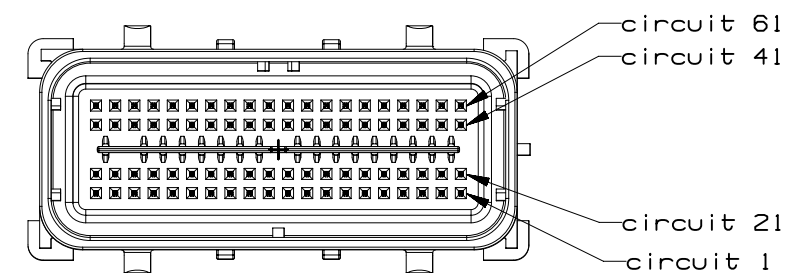

73 CKT COMPONENT CONNECTOR INTERFACE



80 CKT COMPONENT CONNECTOR INTERFACE

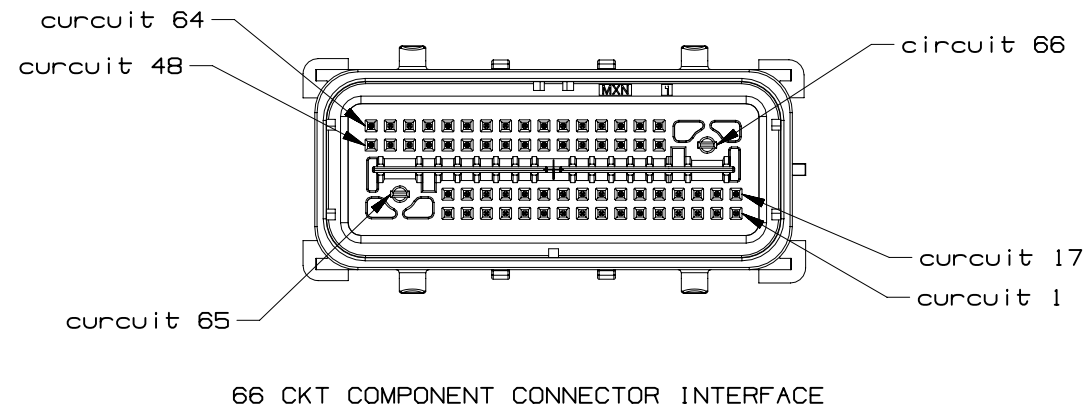
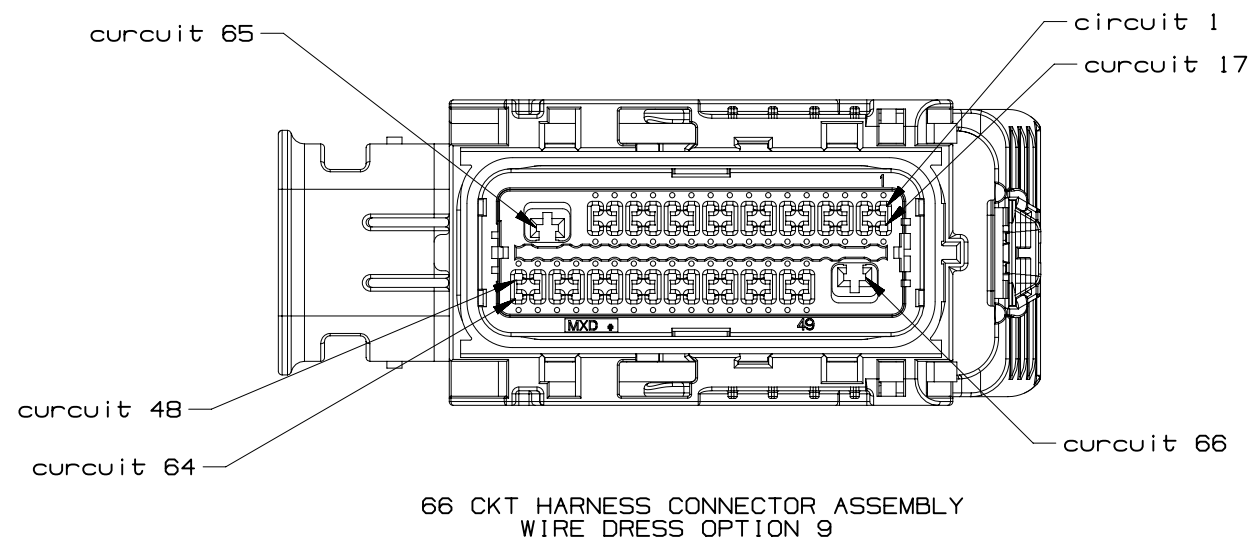
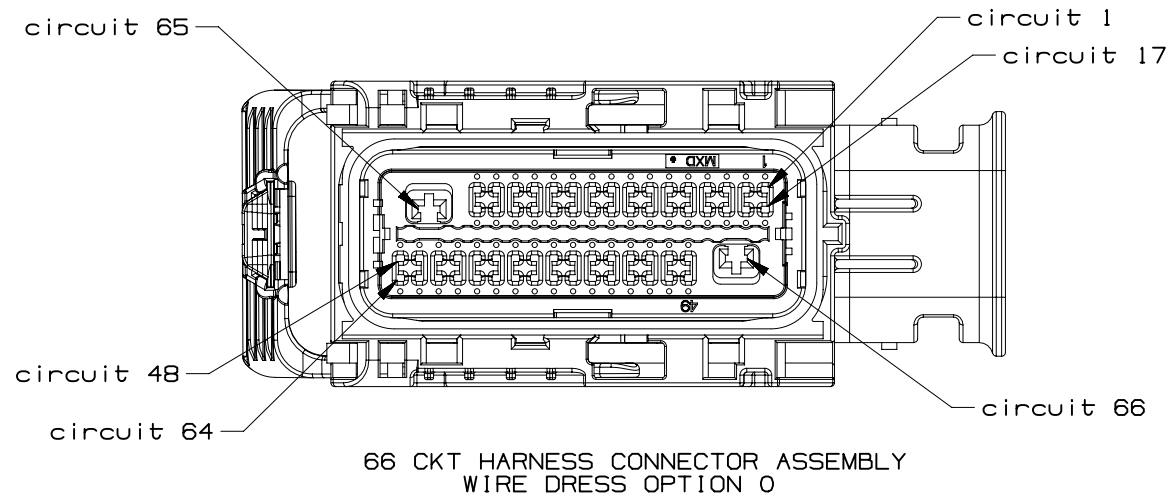



	PAGE TITLE	DRAWING NUMBER	DWG STATUS			PAGE NUMBER	
	CIRCUIT CONFIGURATIONS		12642695	ST	REV	PDI	14 of 21
				R	002		

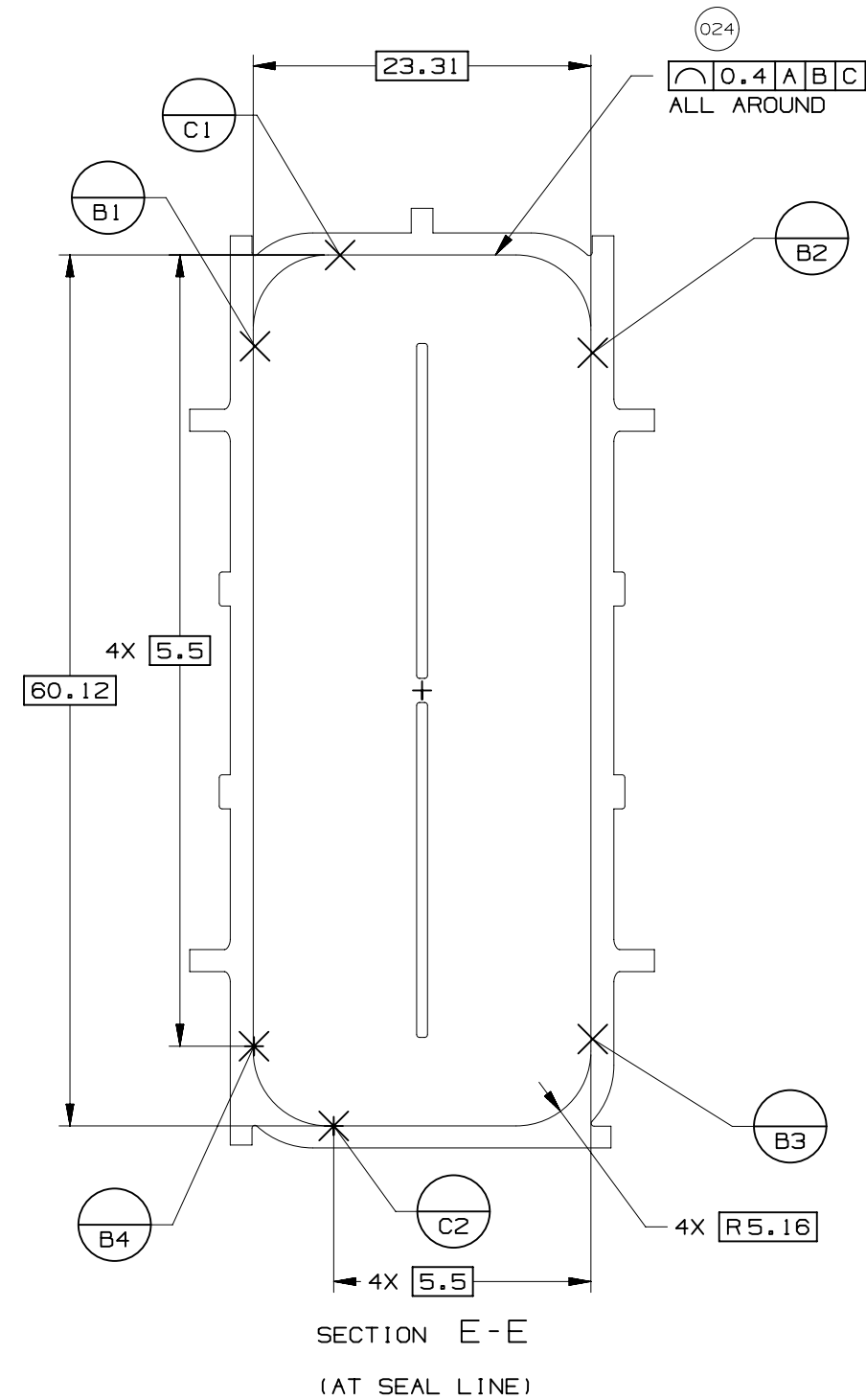
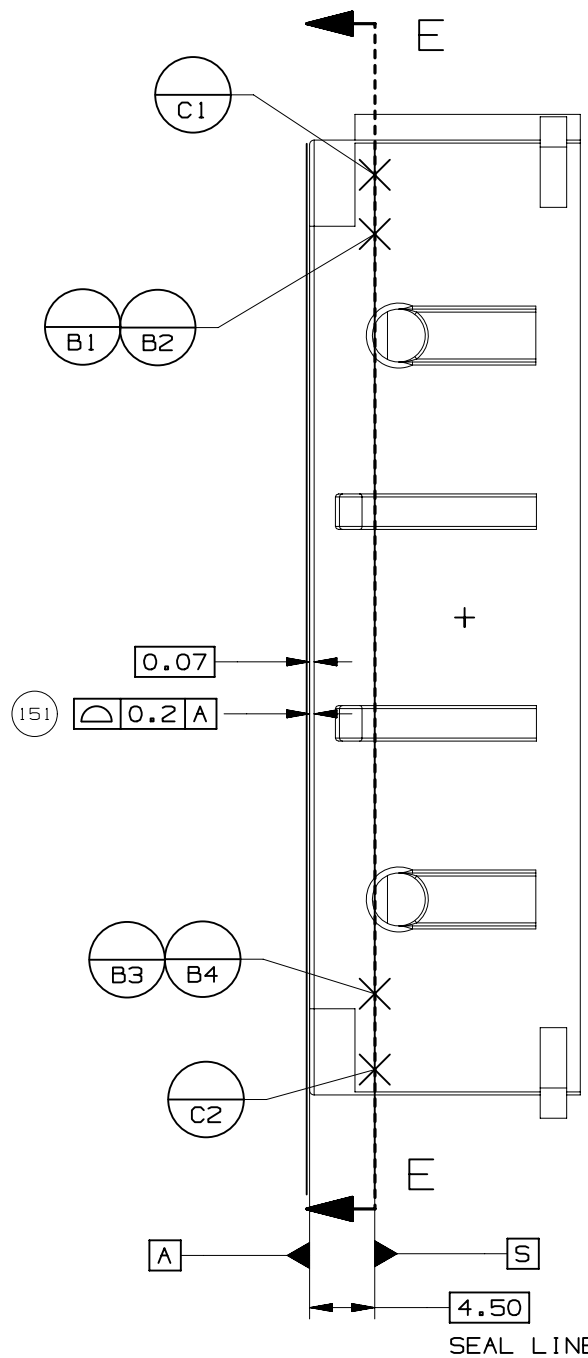
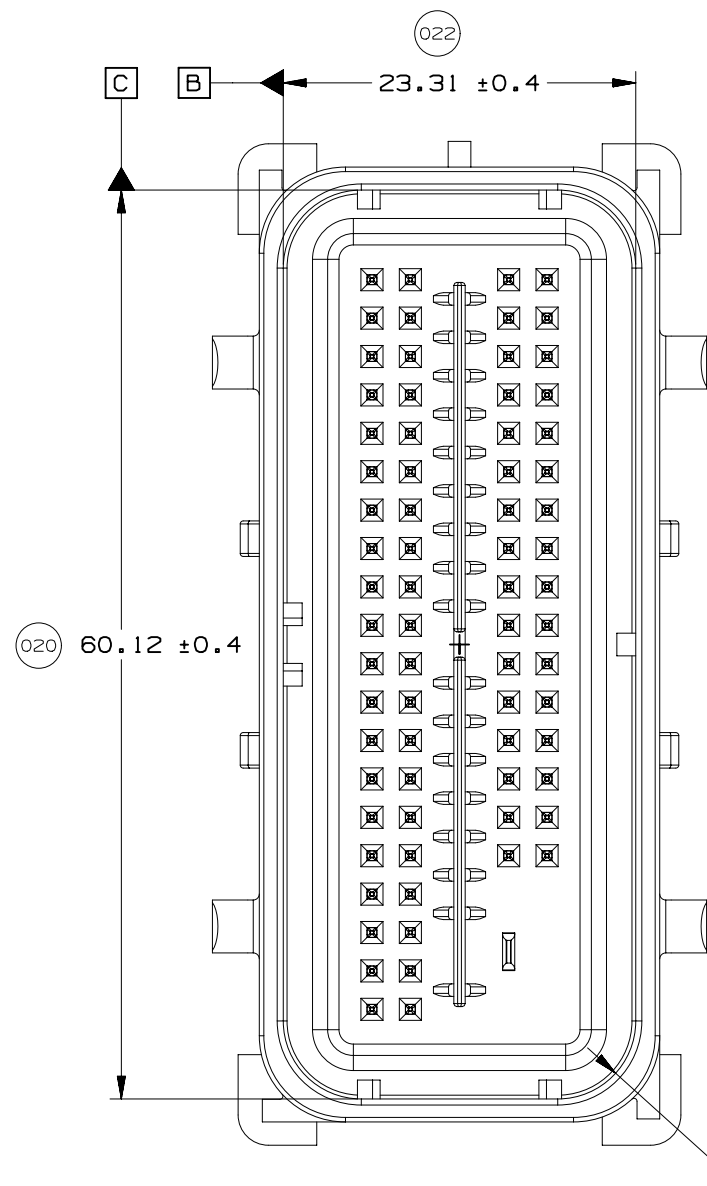
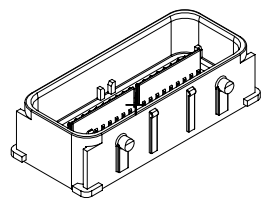

UNLESS SPECIFIED, TOLERANCE OF THE COMPONENT CONNECTOR INTERFACE TO BE $\nabla 0.13 \text{ A B C}$



PAGE TITLE
COMPONENT CONNECTOR INTERFACE

DRAWING NUMBER
12642695

DWG STATUS			PAGE NUMBER
ST	REV	PD1	
R	002		15 OF 21

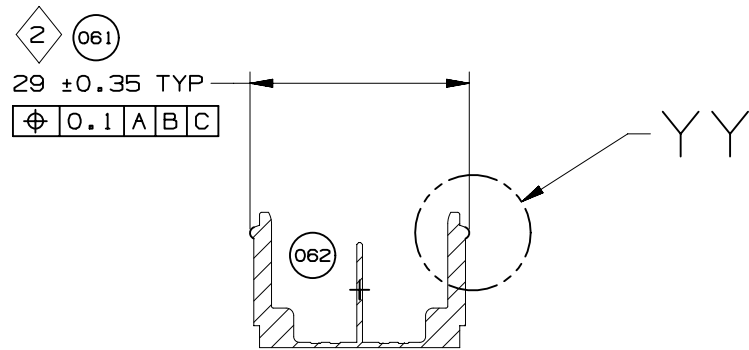
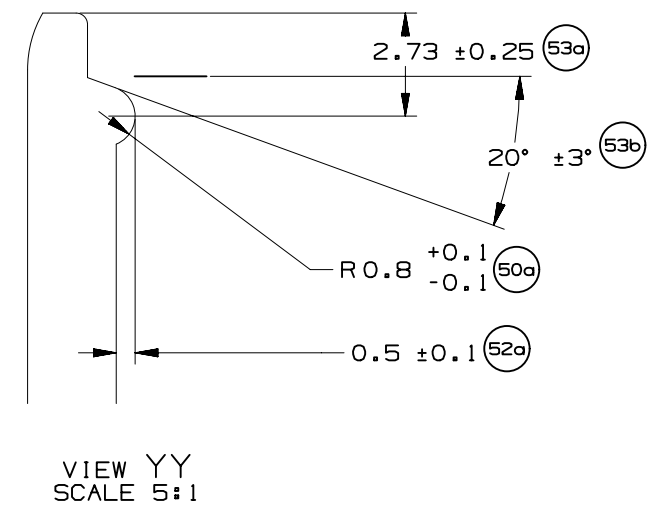
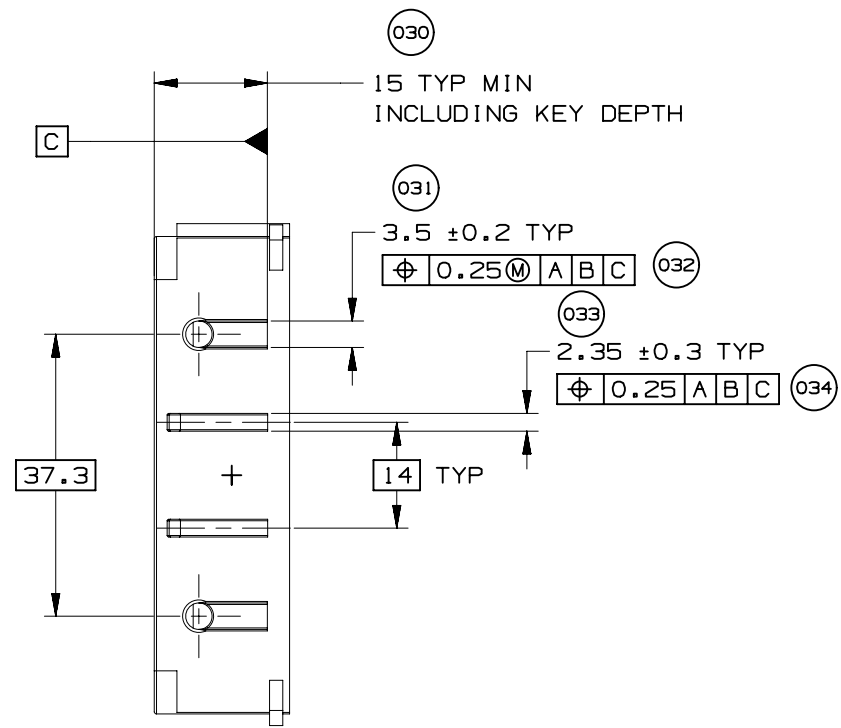
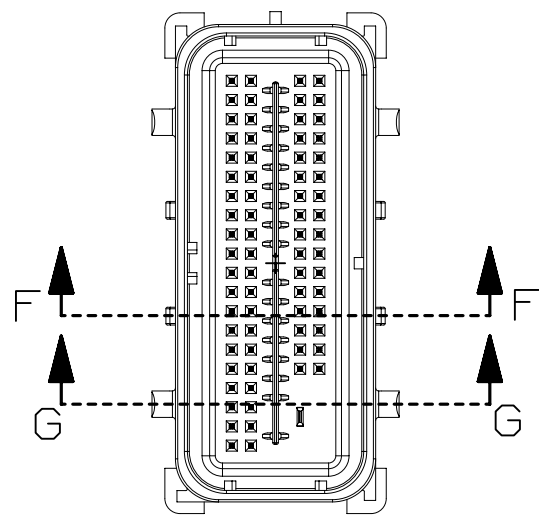

SECTION F-F

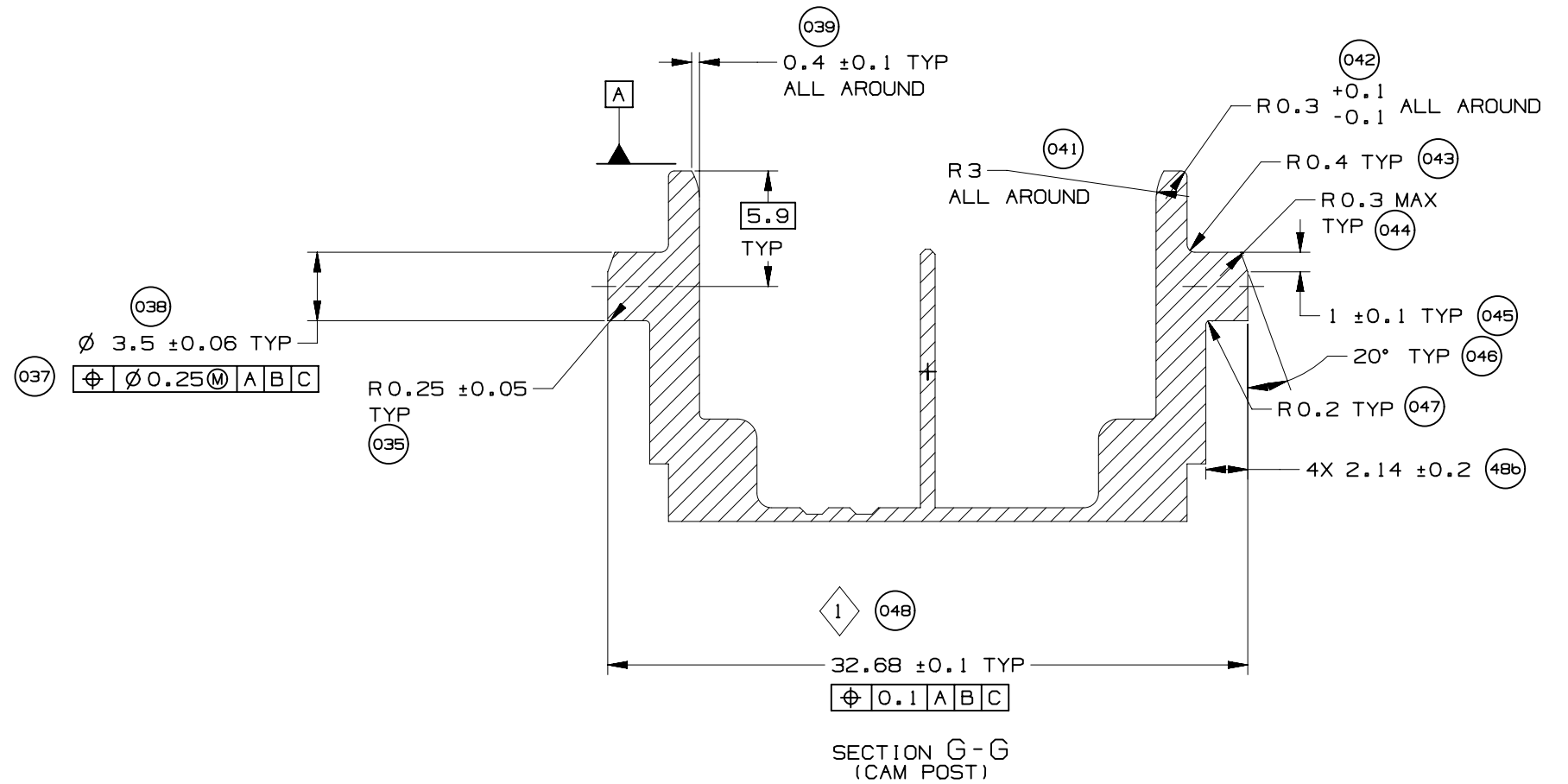

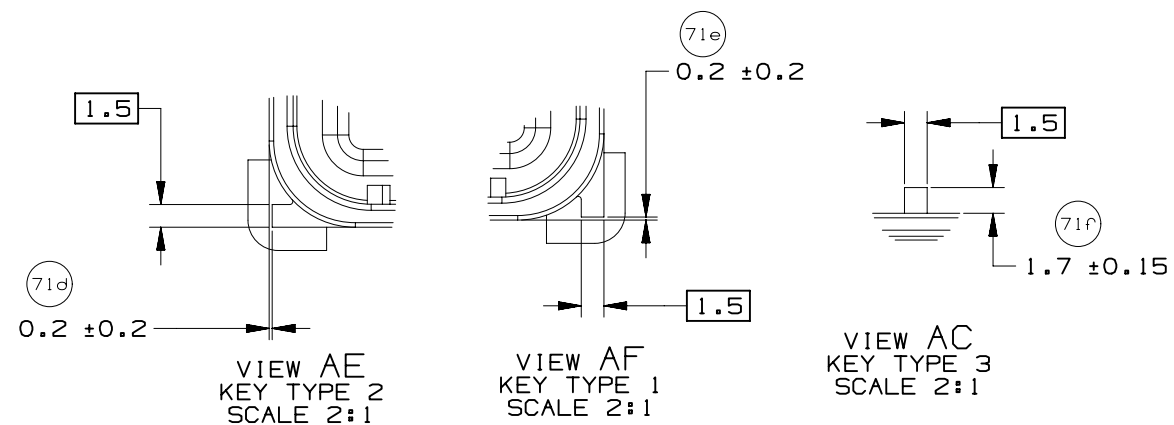
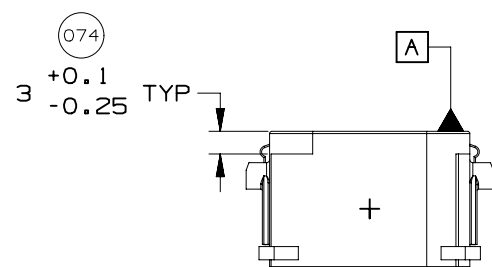
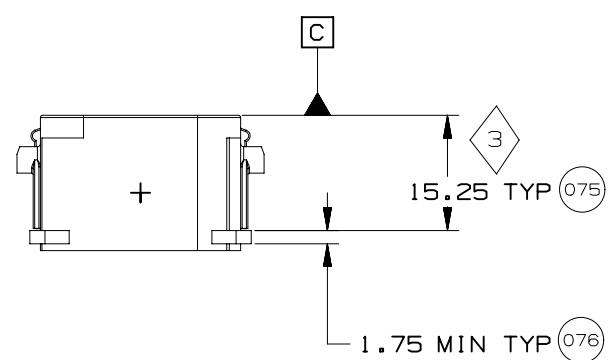
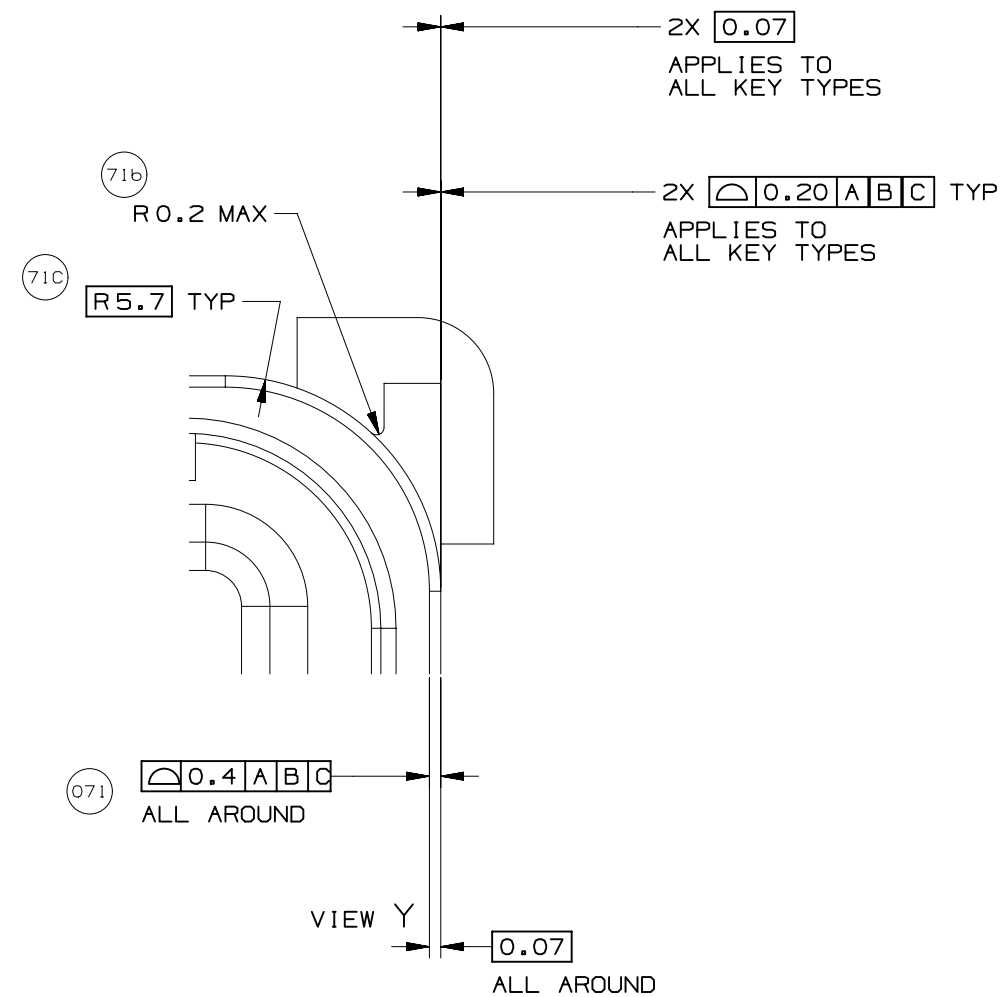
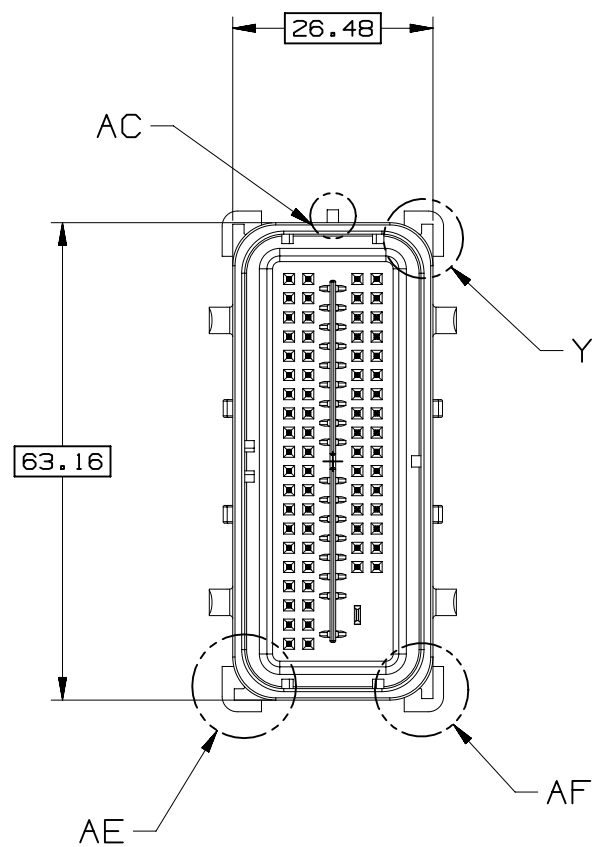
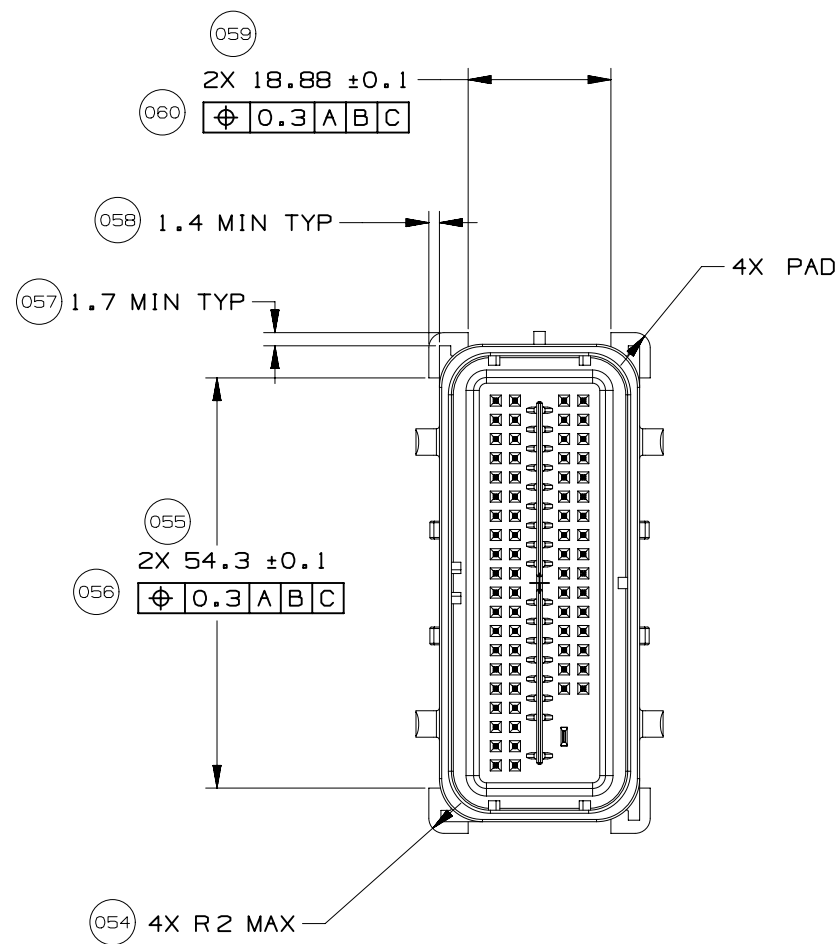

PAGE TITLE
 COMPONENT CONNECTOR INTERFACE

DRAWING NUMBER
 12642695

DWG STATUS			PAGE NUMBER	
ST	REV	PD1		
R	002		17	OF 21

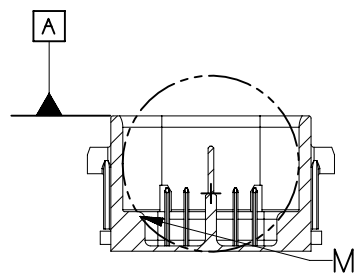
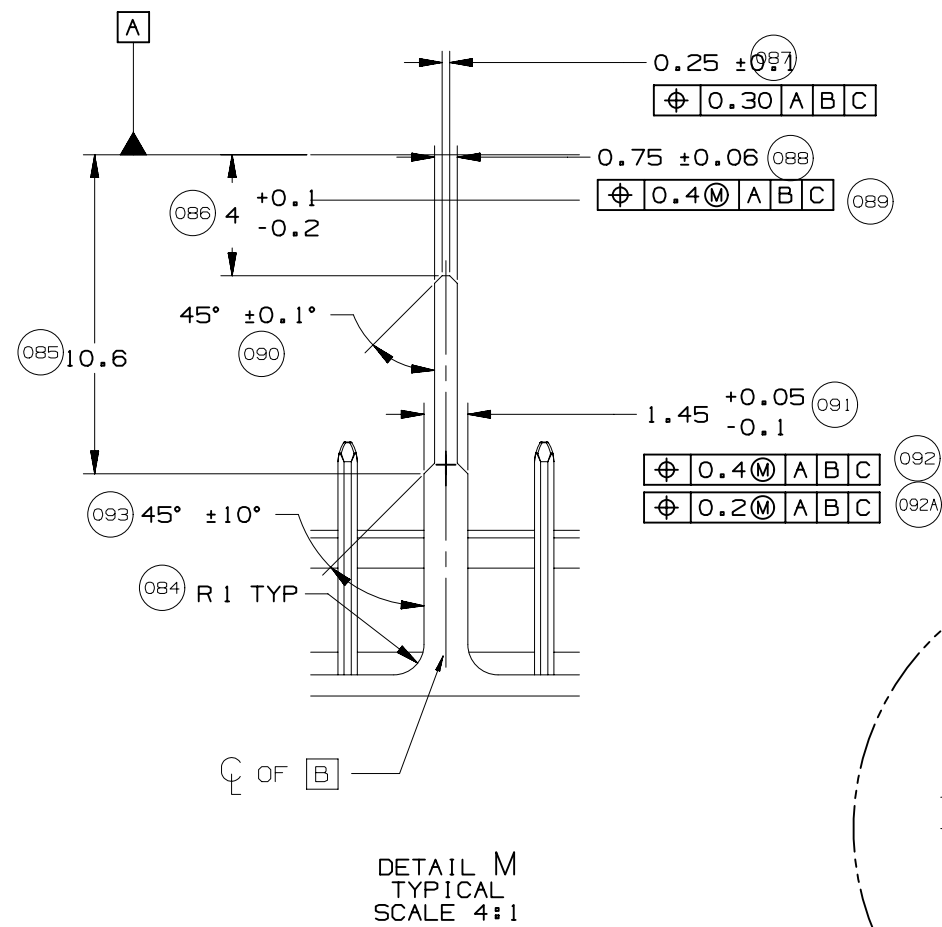
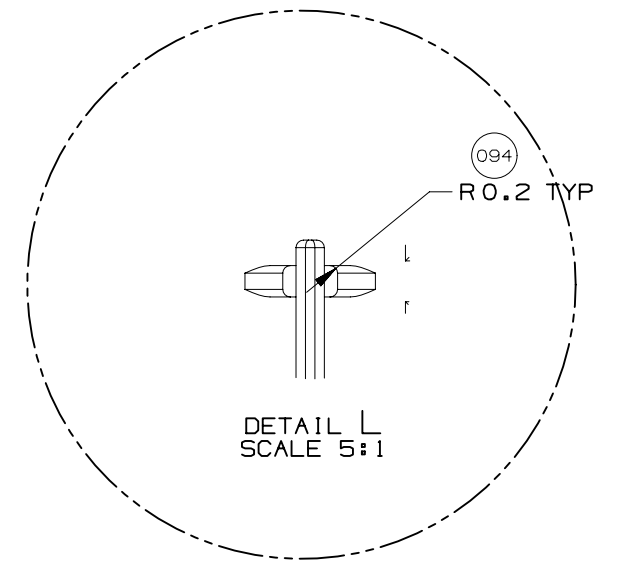
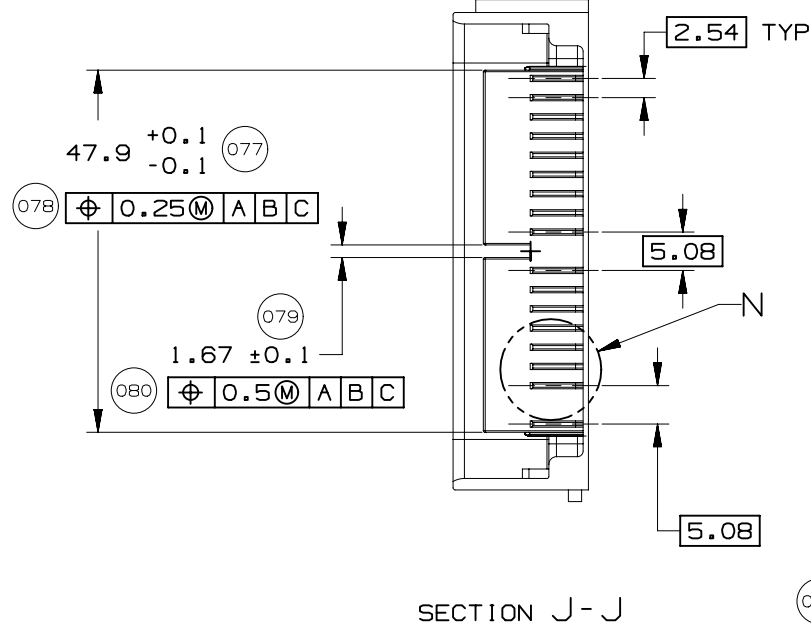
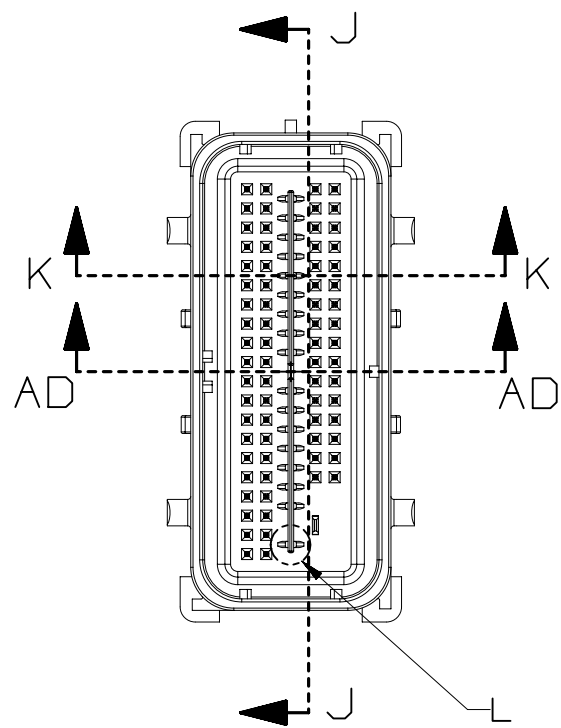

SECTION K-K

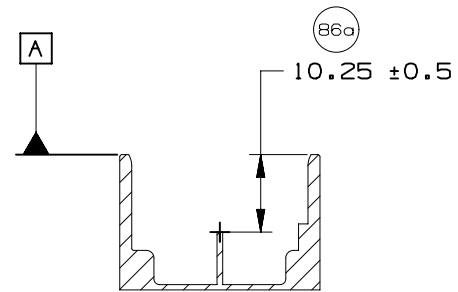

SECTION AD-AD

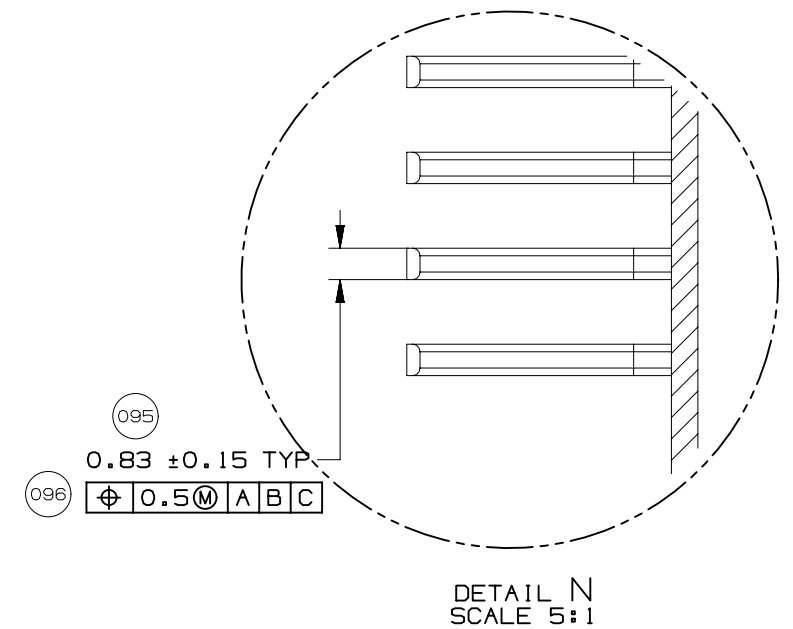

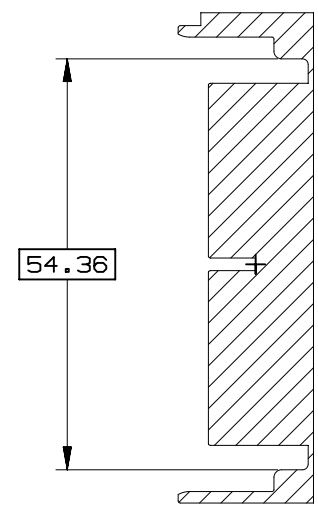
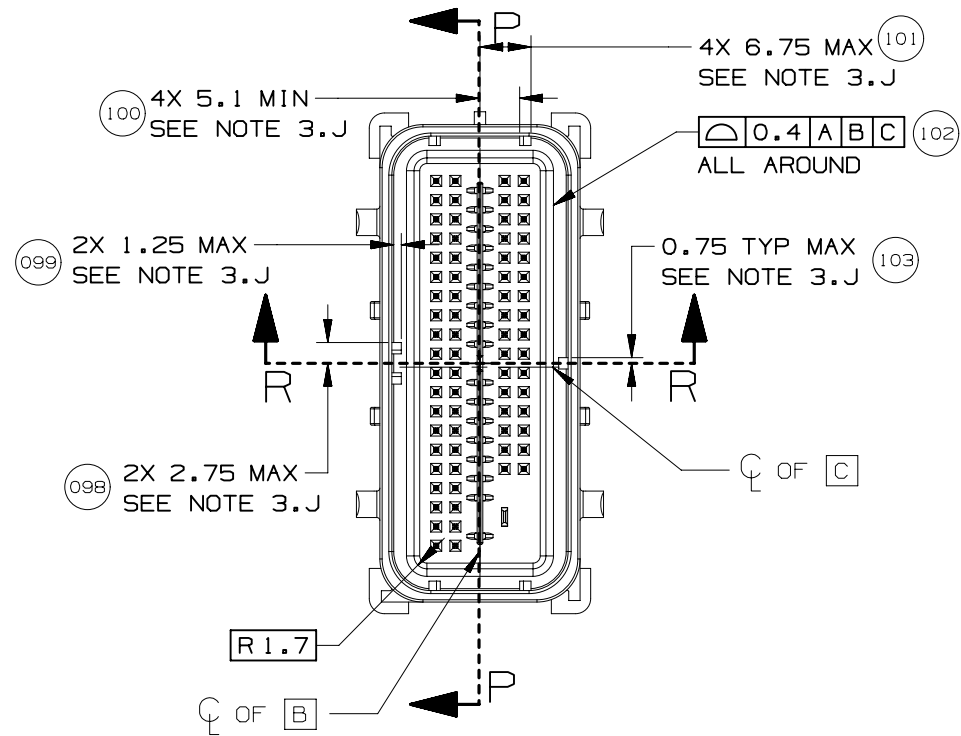

SECTION P-P

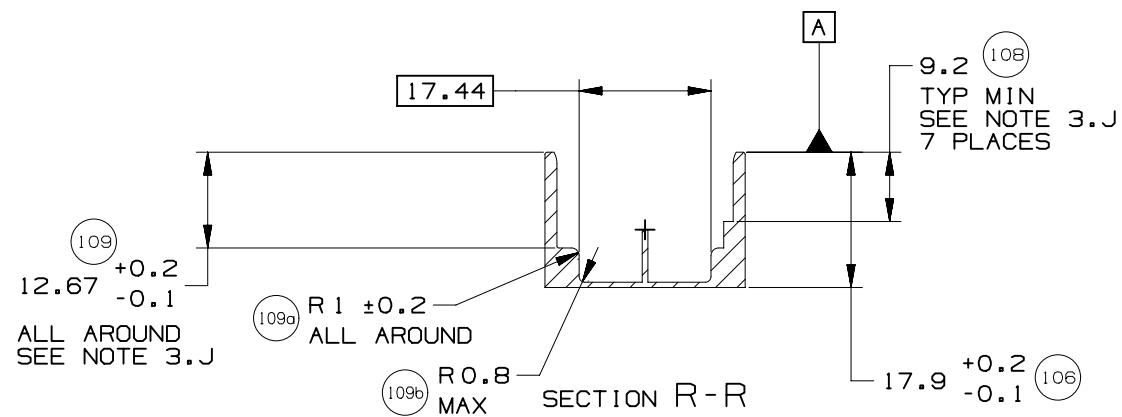

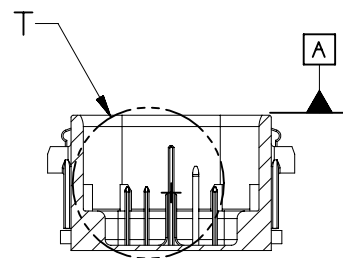
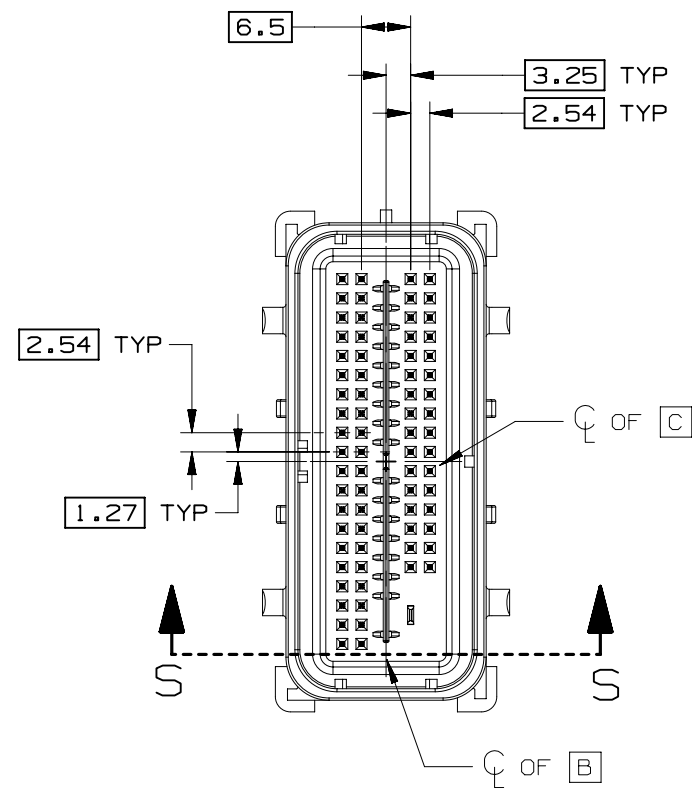

SECTION S-S

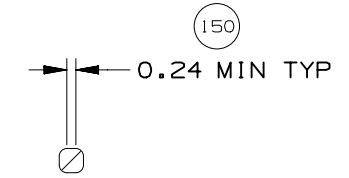
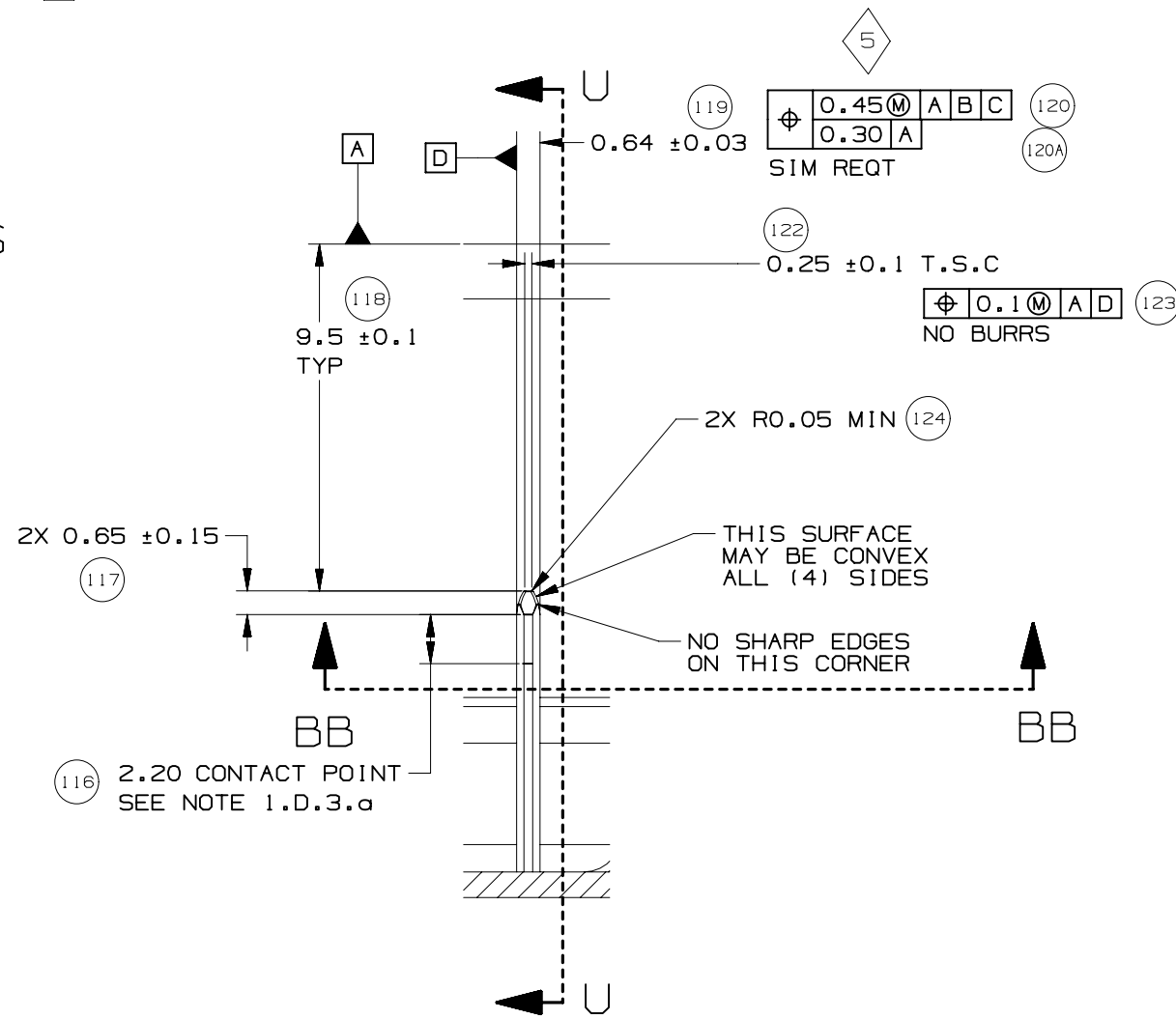

SECTION BB-BB

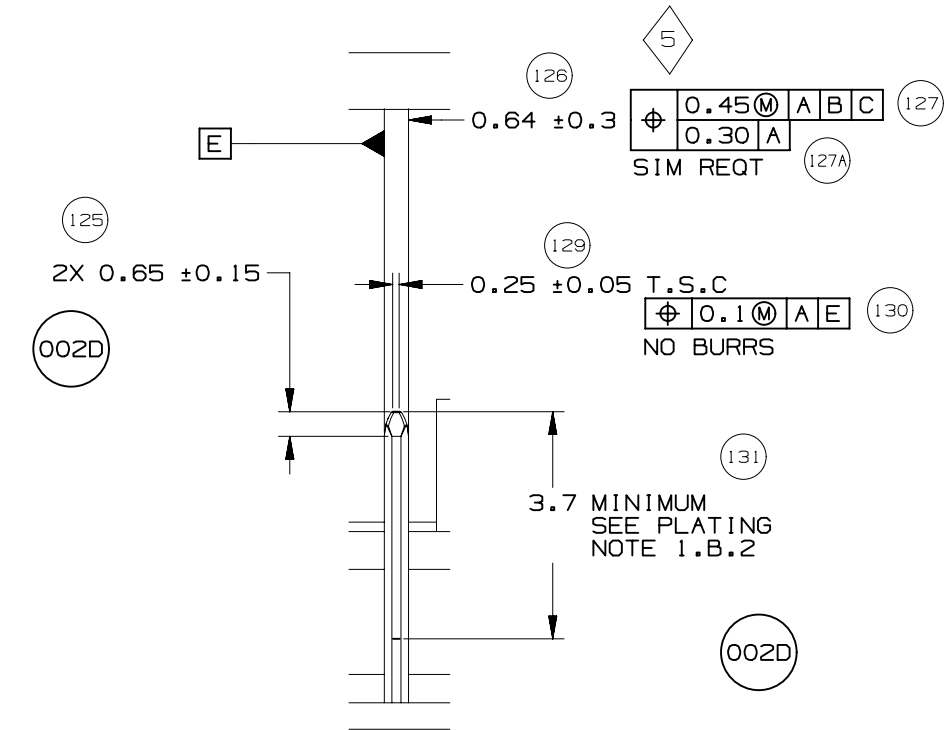

SECTION U-U



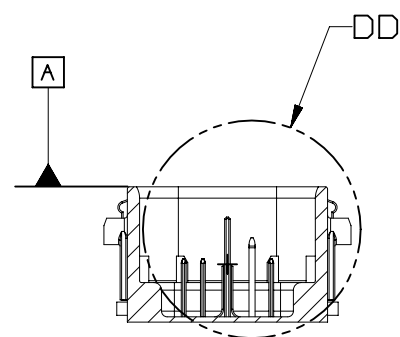
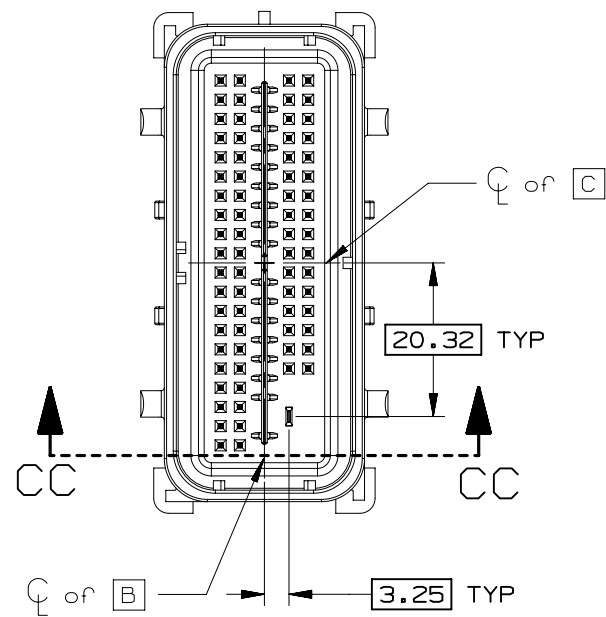

SECTION CC-CC

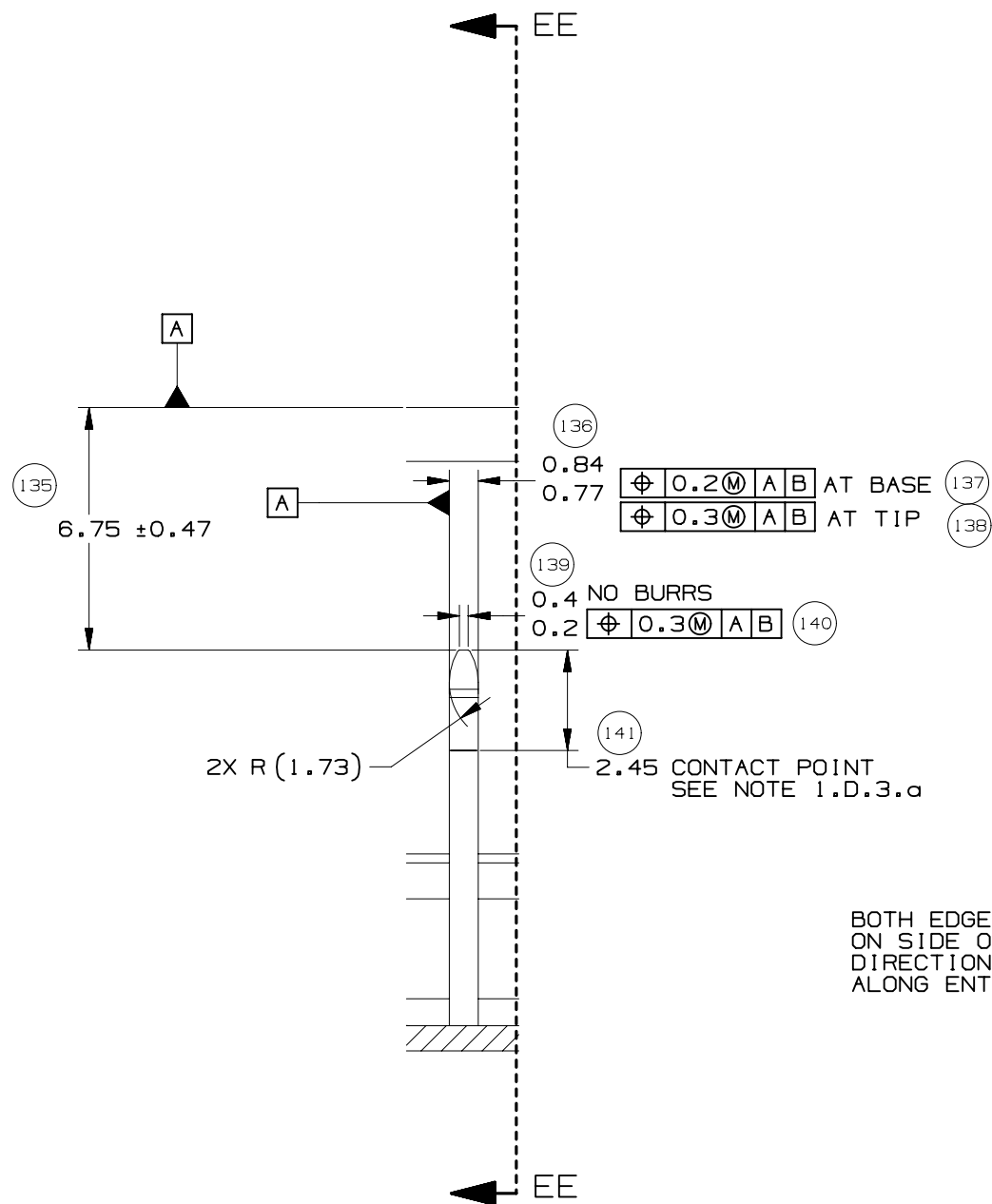

DETAIL DD
TYPICAL
SCALE 5:1

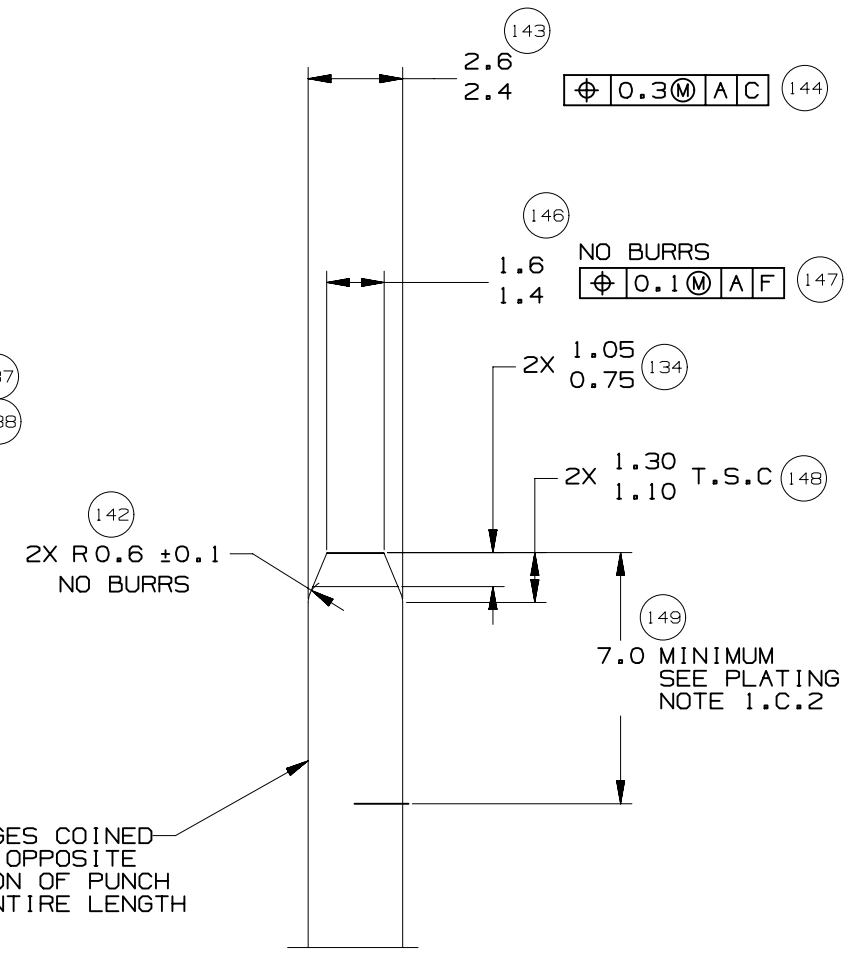

SECTION EE-EE
TYPICAL

BOTH EDGES COINED
ON SIDE OPPOSITE
DIRECTION OF PUNCH
ALONG ENTIRE LENGTH



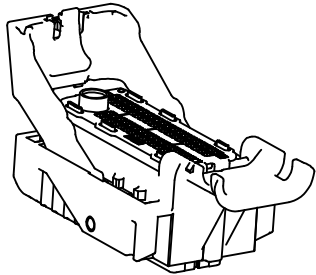

73 CKT
SCALE 3:2

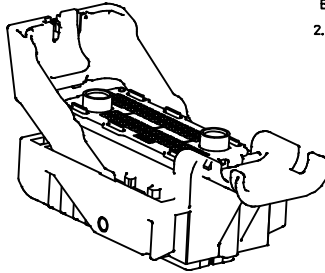
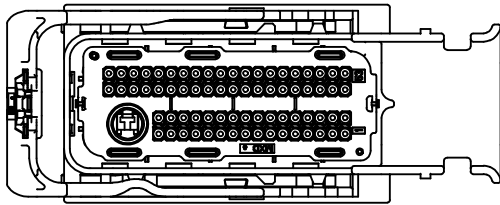

66 CKT
SCALE 3:2

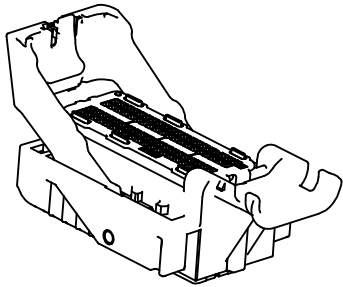
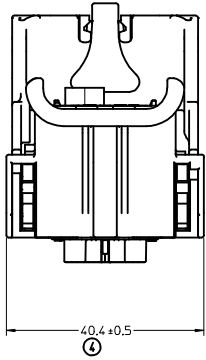
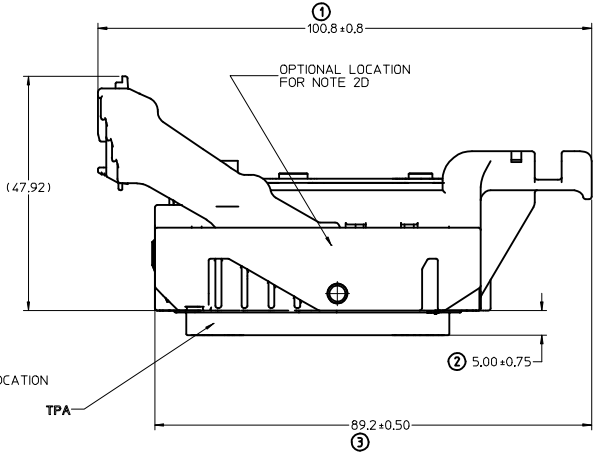
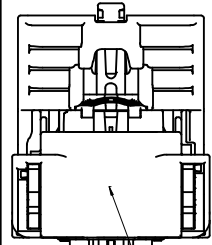

80 CKT
SCALE 3:2

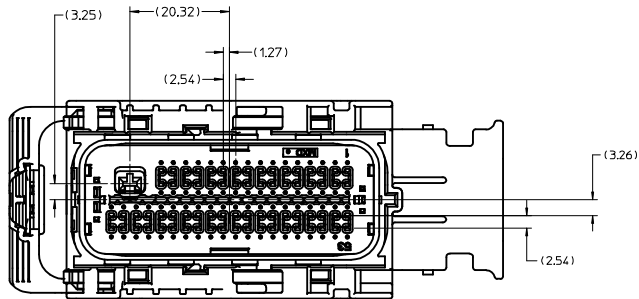

NOTES: UNLESS OTHERWISE SPECIFIED

1. MATERIAL:

- A. RESIN: SEE COMPONENT DRAWINGS
- B. COLOR: SEE TABLE

2. DESIGN - GENERAL:

- A. THIS IS A 100% CAD GENERATED PART. THE CAD MATHEMATICAL DATA IS THE MASTER FOR THIS PART. FOR DIMENSIONAL OR ANY INFORMATION NOT SHOWN ON THIS DRAWING, ANALYZE THE CAD MODEL.
- B. TOLERANCES:
 - a. LINEAR XX ± 0.30
 - XXX ± 0.10
 - XXX ± 0.10
 - b. ANGULAR X° ± 3.0°
- C. CORNERS SHOWN AS SHARP TO BE R 0.2 MAX.
- D. FOLLOWING PRODUCTION CODES TO BE PERMANENTLY MARKED & HUMAN READABLE TO A LETTER HEIGHT < 3mm.
 - LINE #1: MATERIAL #: XXXX-XXXX
 - LINE #2: DATE CODE: JJJ (JULIAN DAY, LAST DIGIT OF YEAR)
 - LINE #3: INSPECTION MACHINE CODE + SERIAL #X_XXXX
- E-1. PARTS MUST BE FREE OF DISCOLORATION, SALT RESIDUE AND OTHER IMPERFECTIONS THAT AFFECT FIT OR FUNCTION.
- E-2. SCRATCHES OR DENTS NOT TO EXCEED 0.15mm IN DEPTH.
- F. CHANGES IN DESIGN FROM PART PREVIOUSLY APPROVED REQUIRES PRIOR ENGINEERING APPROVAL. THIS INCLUDES BUT IS NOT LIMITED TO DRAFT, MATERIAL OR PROCESSING.
- G. SHALL CONFORM TO THE FOLLOWING PACKAGING SPECIFICATION: PK-31300-019

3. DESIGN - MANUFACTURING:

- A. DRAFT TO BE WITHIN TOLERANCE.
- B. ALLOWABLE FLASH 0.2 MAX HIGH X 0.13 MAX THICK.
- C. ALLOWABLE PARTING LINE MISMATCH 0.2 MAX.
- D. EJECTOR PINS MARK TO BE FLUSH TO 0.25 MAX DEPRESSED.
- E. ALLOWABLE GATE VESTIGE TO BE FLUSH TO 0.25 MAX PROTRUSION.

4. SYSTEM REQUIREMENTS:

WHEN TESTED TO SAE/USCAR-2 REV: 3, APRIL 2001, AND GMW #3191, AUGUST 22, 2000 (DRAFT).

- A. TPA (WITHOUT TERMINALS)
 - a. INSERTION FORCE FROM PRE-SET TO LOCK: ≥20
 - b. REMOVAL FORCE FROM PRE-SET: ≥20
- B. CPA
 - a. INSERTION FORCE FROM PRE-SET TO LOCK WITH CONNECTOR UN-MATED: ≥60N
 - b. REMOVAL FORCE FROM PRE-SET: ≥30N
- C. GROMMET CAP
 - a. REMOVAL FORCE FROM HOUSING WITH ENGAGED LATCHES: ≥110N
- D. MATE ASSIST LEVER
 - a. INADVERTENT ACTUATION FORCE DURING SHIPPING, HANDLING OR PRE-ASSEMBLY: ≥190N

REV	DESCRIPTION
G34	ADDED PART NUMBERS 34566-7753
G33	ADDED PART NUMBERS 34566-7743
G32	ADDED PART NUMBERS 34566-7693 34566-7713 34566-7723 34566-7733
G31	ADDED PART NUMBERS 34566-7653 34566-7663 34566-7673 34566-7683
G30	ADDED PART NUMBERS 34566-7633 34566-7843 34822-0143 CHANGE THE 34822-0093 TO OPTION 9
G29	ADDED PART NUMBERS 34822-0113 34822-0123 34566-7613 34566-7623 34822-0133
G28	ADDED PART NUMBERS 34566-7593 34822-0093 34822-0103 34566-5793 SAME AS P/N 34566-4013
G27	ADDED PART NUMBERS 34566-7573 34566-7583
G26	ADDED PART NUMBERS 34566-7543 34566-7553 34566-7563 SAME AS P/N 34566-6553 35466-1983 35466-1993
G25	ADDED PART NUMBERS 34566-7363 34566-7373 34566-7383 34566-7393 34566-7413 34566-7423 34566-7433 34566-7443 34566-7453 34566-7463 34566-7473 34566-7483 34566-7493 34566-7513 34566-7523 34566-7533
G24	ADDED PART NUMBERS 34566-7233 34566-7333 34566-7343 34566-7353 34822-0073 OPTION 9 CHANGE TO OPTION 0
G23	ADDED PART NUMBERS 34566-7283 34566-7293 34566-7313 34822-0073 34822-0083
G22	ADDED PART NUMBERS 34566-6993 34566-7013 34566-7023 34566-7033 34566-7043 34566-7053 34566-7063 34566-7073 34566-7083 34566-7093 34566-7113 34566-7123 34566-7133 34566-7143 34566-7153 34566-7163 34566-7173 34566-7183 34566-7193 34566-7213 34566-7223 34566-7233 34566-7243
G21	ADDED PART NUMBERS 34566-6933 34566-6943 34566-6953 34566-6963 34566-6973 34566-6983
G20	ADDED PART NUMBERS 34566-6893 34566-6913 34566-6923
G19	UPDATE 73CKT KEY F OPT 0 AND OPT 9 GM PART NUMBER
G18	ADDED PART NUMBERS 34566-6863 34566-6873 34566-6883
G17	ADDED PART NUMBERS 34822-6813 34566-6823 34566-6833 34566-6843 34566-6853
G16	ADDED PART NUMBERS 34822-0063 34566-6713 34566-6723 34566-6733 34566-6743 34566-6753 34566-6763 34566-6773 34566-6783 34566-6793

ENTER DESCRIPTION EEC NO: UAU2016-0232 DRAWN BY: 2015/08/14 CHKD: 2015/08/14 APPR: IKOSHY REV: G34	QUALITY SYMBOLS ∇=0 ∇=0 ∇=0	GENERAL TOLERANCES (UNLESS SPECIFIED): mm INCH 4 PLACES ± --- ± --- 3 PLACES ± --- ± --- 2 PLACES ± --- ± --- 1 PLACE ± --- ± --- 0 PLACE ± --- ± --- ANGULAR ± --- ° DRAFT WHERE APPLICABLE MUST REMAIN WITHIN DIMENSIONS	DIMENSION STYLE MM ONLY DRAWN BY: SKRAJENDRANA 2011/02/14 DATE: --- CHECKED BY: MVANSLAMBROU 2011/02/14 DATE: --- APPROVED BY: --- DATE: ---	SCALE 2:1	DESIGN UNITS METRIC	THIRD ANGLE PROJECTION	MX123 66/73/80CKT HRNS CONN ASSY molex	MATERIAL NO. SEE BOM TABLE	DOCUMENT NO. SD-34566-001	SHEET NO. 1 OF 85											
											THIS DRAWING CONTAINS INFORMATION THAT IS PROPRIETARY TO MOLEX INCORPORATED AND SHOULD NOT BE USED WITHOUT WRITTEN PERMISSION										
											DRAFT										
											REV: G34										

80 CKT

WIRE DRESS OPTION 0

HOUSING ONLY, SHOWN FOR CLARITY

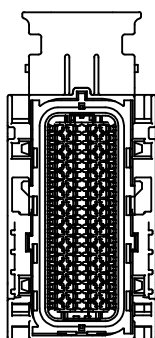
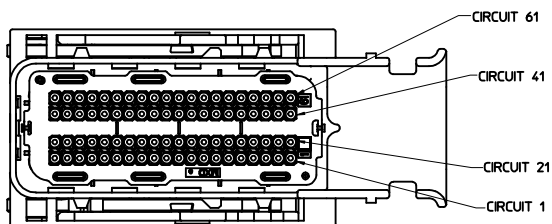

KEY G

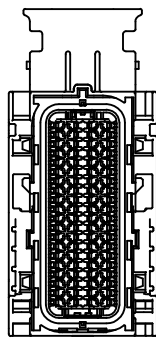

KEY H

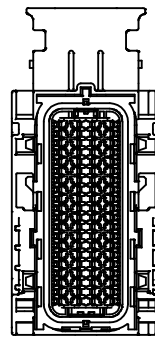

KEY J

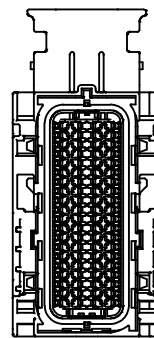

KEY K

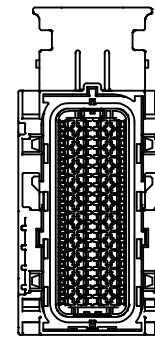

KEY L

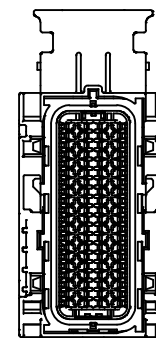

KEY M

WIRE DRESS OPTION 9

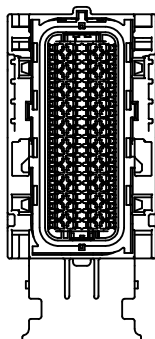
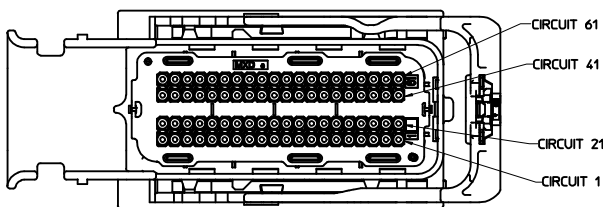

KEY G

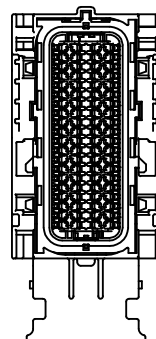

KEY H

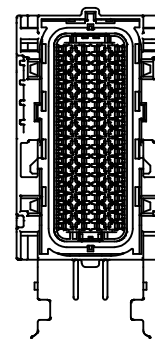

KEY J

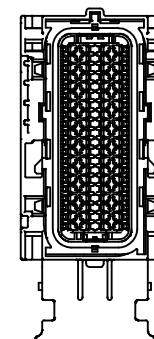

KEY K

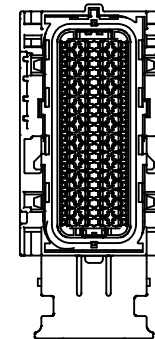

KEY L

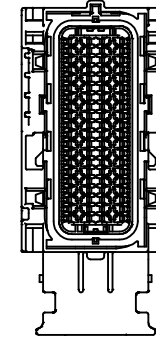

KEY M

ENTER DESCRIPTION EC NO: UAU2016-0232 DRAWN BY: CHYD CHKD: APPR: WOSHY G34 REV:	2015/08/14 DESCRIPTION	QUALITY SYMBOLS ▽=0 ▽=0 ▽=0	GENERAL TOLERANCES (UNLESS SPECIFIED) mm INCH 4 PLACES +--- +--- 3 PLACES +--- +--- 2 PLACES +--- +--- 1 PLACE +--- +--- 0 PLACE +--- +---	DIMENSION STYLE MM ONLY	SCALE 1.5:1	DESIGN UNITS METRIC	THIRD ANGLE PROJECTION
	DRAWN BY: SKRAJENDRANA DATE: 2011/02/14	CHECKED BY: MYANSLAMBROU DATE: 2011/02/14	APPROVED BY:	MATERIAL NO.	DOCUMENT NO.	TITLE MX123 66/73/80CKT HRNS CONN ASSY	SHEET NO. 2 OF 85
	SEE BOM TABLE	SD-34566-001	THIS DRAWING CONTAINS INFORMATION THAT IS PROPRIETARY TO MOLEX INCORPORATED AND SHOULD NOT BE USED WITHOUT WRITTEN PERMISSION				
	DRAFT WHERE APPLICABLE MUST REMAIN WITHIN DIMENSIONS						

73 CKT

WIRE DRESS OPTION 0

HOUSING ONLY, SHOWN FOR CLARITY

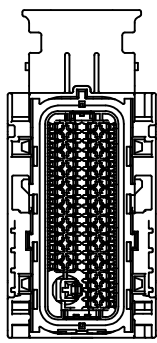
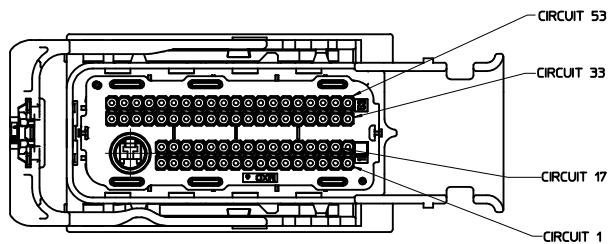

KEY A

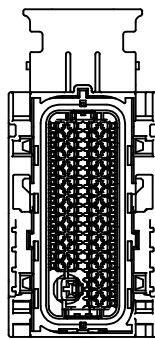

KEY B

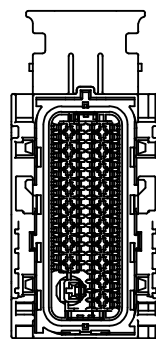

KEY O

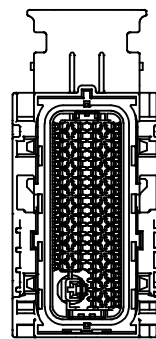

KEY D

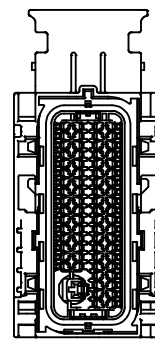

KEY E

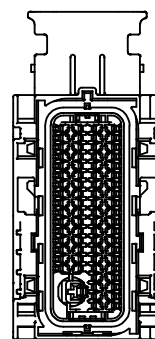

KEY F

WIRE DRESS OPTION 9

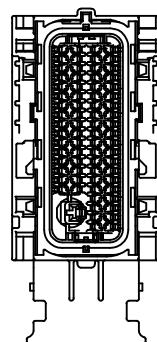
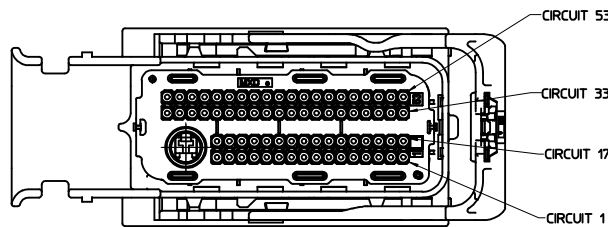

KEY A

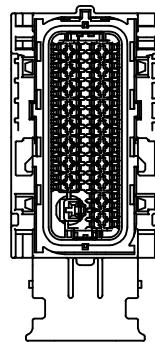

KEY B

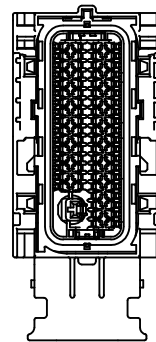

KEY O

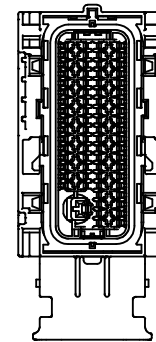

KEY D

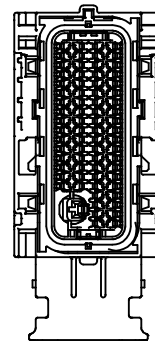

KEY E

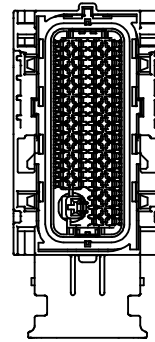

KEY F

ENTER DESCRIPTION EEC NO: UAU2016-0232 DRAWN BY: GJ CHKD: GJ APPR: VKOSHY 2015/08/14 2015/08/14	QUALITY SYMBOLS	GENERAL TOLERANCES (UNLESS SPECIFIED)		DIMENSION STYLE	SCALE	DESIGN UNITS	THIRD ANGLE PROJECTION
	▽=0	mm	INCH	MM ONLY	1.5:1	METRIC	
	▽=0	4 PLACES	+	SKRAJENDRANA 2011/02/14	DATE	TITLE	
	▽=0	3 PLACES	+	MYANSLAMBROU 2011/02/14	DATE		
▽=0	2 PLACES	+		DATE			MX123
	1 PLACE	+		DATE			66/73/80CKT
	0 PLACE	+		DATE			HRNS CONN ASSY
		ANGULAR ±					molex
		DRAFT WHERE APPLICABLE		MATERIAL NO.	DOCUMENT NO.		SD-34566-001
		MUST REMAIN WITHIN DIMENSIONS		SEE BOM TABLE			SHEET NO. 3 OF 85
				THIS DRAWING CONTAINS INFORMATION THAT IS PROPRIETARY TO MOLEX INCORPORATED AND SHOULD NOT BE USED WITHOUT WRITTEN PERMISSION			

66 CKT

WIRE DRESS OPTION 0

HOUSING ONLY, SHOWN FOR CLARITY

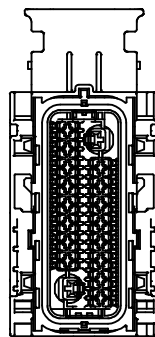
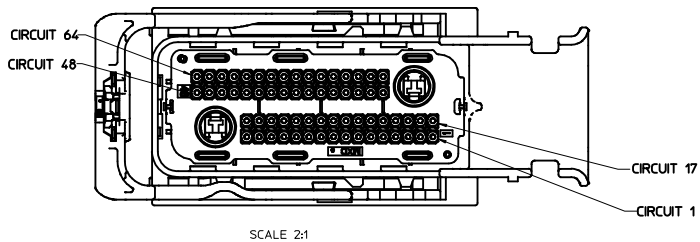

KEY A

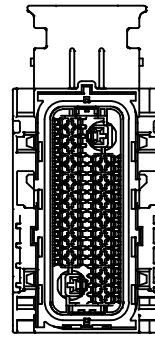

KEY C

WIRE DRESS OPTION 9

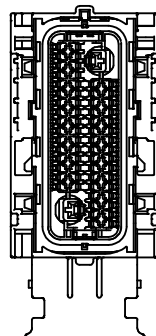
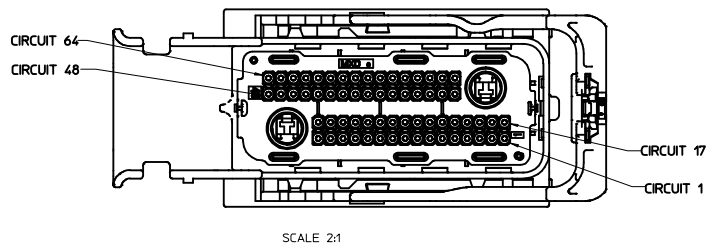

KEY A

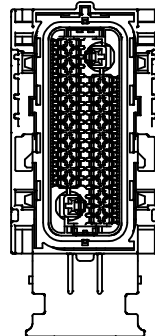

KEY C

ENTER DESCRIPTION EC NO: UAU2016-0232 DRAWN BY G34 CHKD: APPR: WOSHY REV DESCRIPTION 2015/08/14 2015/08/14	QUALITY SYMBOLS ▽=0 ▽=0 ▽=0	GENERAL TOLERANCES (UNLESS SPECIFIED) <table border="1"> <tr> <th></th> <th>mm</th> <th>INCH</th> </tr> <tr> <td>4 PLACES</td> <td>±----</td> <td>±----</td> </tr> <tr> <td>3 PLACES</td> <td>±---</td> <td>±---</td> </tr> <tr> <td>2 PLACES</td> <td>±--</td> <td>±--</td> </tr> <tr> <td>1 PLACE</td> <td>±</td> <td>±</td> </tr> <tr> <td>0 PLACE</td> <td></td> <td></td> </tr> </table> ANGULAR ±----- DRAFT WHERE APPLICABLE MUST REMAIN WITHIN DIMENSIONS		mm	INCH	4 PLACES	±----	±----	3 PLACES	±---	±---	2 PLACES	±--	±--	1 PLACE	±	±	0 PLACE			DIMENSION STYLE MM ONLY DRAWN BY SKRAJENDRANA DATE 2011/02/14 CHECKED BY DATE MYANSLAMBROU 2011/02/14 APPROVED BY DATE	SCALE 1.5:1 DESIGN UNITS METRIC THIRD ANGLE PROJECTION	TITLE MX123 66/73/80CKT HRNS CONN ASSY molex	MATERIAL NO. SEE BOM TABLE DOCUMENT NO. SD-34566-001 SHEET NO. 4 OF 85
		mm	INCH																					
	4 PLACES	±----	±----																					
3 PLACES	±---	±---																						
2 PLACES	±--	±--																						
1 PLACE	±	±																						
0 PLACE																								
THIS DRAWING CONTAINS INFORMATION THAT IS PROPRIETARY TO MOLEX INCORPORATED AND SHOULD NOT BE USED WITHOUT WRITTEN PERMISSION																								
SIZE D																								

STATUS	GM PART #	MATERIAL #	PART/MATERIAL REVISION	WIRE DRESS OPTION	KEY OPTION	COLOR (TPA)	NUMBERS INDICATE CAVITIES OPEN FOR CIRCUITS
AVAILABLE	12582677	34566-0103	G	0	A	BLACK	
AVAILABLE	12582678	34566-0203	G	0	B	ST GRY	72 71 70 69 68 67 66 65 64 63 62 61 60 59 58 57 56 55 54 53
AVAILABLE	12615654	34566-0303	G	0	C	BLUE	52 51 50 49 48 47 46 45 44 43 42 41 40 39 38 37 36 35 34 33
ACTIVE	12615660	34566-0403	G	0	D	BROWN	
ACTIVE	12615661	34566-0503	G	0	E	GREEN	73 32 31 30 29 28 27 26 25 24 23 22 21 20 19 18 17
AVAILABLE	12653574	34566-0603	G	0	F	NATURAL	16 15 14 13 12 11 10 9 8 7 6 5 4 3 2 1
AVAILABLE	12588057	34566-0703	G	0	G	BLUE	
AVAILABLE	12588058	34566-0803	G	0	H	ST GRY	80 79 78 77 76 75 74 73 72 71 70 69 68 67 66 65 64 63 62 61
ACTIVE	12615658	34566-0903	G	0	J	BLACK	60 59 58 57 56 55 54 53 52 51 50 49 48 47 46 45 44 43 42 41
ACTIVE	TBD	34566-1003	G	0	K	BROWN	40 39 38 37 36 35 34 33 32 31 30 29 28 27 26 25 24 23 22 21
ACTIVE	TBD	34566-1103	G	0	L	GREEN	20 19 18 17 16 15 14 13 12 11 10 9 8 7 6 5 4 3 2 1
ACTIVE	TBD	34566-1203	G	0	M	NATURAL	
AVAILABLE	12603596	34566-1303	G	9	A	BLACK	
AVAILABLE	12603597	34566-1403	G	9	B	ST GRY	72 71 70 69 68 67 66 65 64 63 62 61 60 59 58 57 56 55 54 53
AVAILABLE	12615655	34566-1503	G	9	C	BLUE	52 51 50 49 48 47 46 45 44 43 42 41 40 39 38 37 36 35 34 33
ACTIVE	12615663	34566-1603	G	9	D	BROWN	
ACTIVE	12615664	34566-1703	G	9	E	GREEN	73 32 31 30 29 28 27 26 25 24 23 22 21 20 19 18 17
AVAILABLE	12653575	34566-1803	G	9	F	NATURAL	16 15 14 13 12 11 10 9 8 7 6 5 4 3 2 1
AVAILABLE	12603598	34566-1903	G	9	G	BLUE	
AVAILABLE	12603599	34566-2003	G	9	H	ST GRY	80 79 78 77 76 75 74 73 72 71 70 69 68 67 66 65 64 63 62 61
ACTIVE	12615659	34566-2103	G	9	J	BLACK	60 59 58 57 56 55 54 53 52 51 50 49 48 47 46 45 44 43 42 41
ACTIVE	TBD	34566-2203	G	9	K	BROWN	40 39 38 37 36 35 34 33 32 31 30 29 28 27 26 25 24 23 22 21
ACTIVE	TBD	34566-2303	G	9	L	GREEN	20 19 18 17 16 15 14 13 12 11 10 9 8 7 6 5 4 3 2 1
ACTIVE	TBD	34566-2403	G	9	M	NATURAL	
AVAILABLE	TBD	34822-0013	A	0	A	BLACK	64 63 62 61 60 59 58 57 56 55 54 53 52 51 50 49 48 47 46 45 44 43 42 41 40 39 38 37 36 35 34 33 66
AVAILABLE	TBD	34822-0033	A	0	C	BLUE	65 32 31 30 29 28 27 26 25 24 23 22 21 20 19 18 17 16 15 14 13 12 11 10 9 8 7 6 5 4 3 2 1
AVAILABLE	TBD	34822-0023	A	9	A	BLACK	64 63 62 61 60 59 58 57 56 55 54 53 52 51 50 49 48 47 46 45 44 43 42 41 40 39 38 37 36 35 34 33 66
AVAILABLE	TBD	34822-0043	A	9	C	BLUE	65 32 31 30 29 28 27 26 25 24 23 22 21 20 19 18 17 16 15 14 13 12 11 10 9 8 7 6 5 4 3 2 1
N/A	N/A	N/A	N/A	N/A	N/A	N/A	73
AVAILABLE	NOT APPLICABLE	34566-2503	G	0	A	BLACK	72 71 69 68 67 66 64 63 62 59 56 53 52 51 50 49 48 47 46 45 44 43 42 39 36 35 33 73 32 30 29 27 23 20 17 14 13 12 11 9 8 5 4 3 2 1

SEE NEXT PAGE FOR ADDITIONAL NUMBERS

ENTER DESCRIPTION EC NO: UAU2016-0232 DRAWN BY: 2015/08/14 CHKD: 2015/08/14 APPR: IKOSHY REV: G34	QUALITY SYMBOLS ∇=0 ∇=0 ∇=0	GENERAL TOLERANCES (UNLESS SPECIFIED) mm INCH 4 PLACES +--- +--- 3 PLACES +--- +--- 2 PLACES +--- +--- 1 PLACE +--- +--- 0 PLACE +--- +---	DIMENSION STYLE MM ONLY	SCALE DESIGN UNITS METRIC	THIRD ANGLE PROJECTION	
	ANGULAR ±---° DRAFT WHERE APPLICABLE MUST REMAIN WITHIN DIMENSIONS	DRAWN BY: SKRAJENDRANA 2011/02/14 CHECKED BY: MYANSLAMBROU 2011/02/14 APPROVED BY:	DATE:	TITLE: MX123 66/73/80CKT HRNS CONN ASSY	MATERIAL NO. SD-34566-001	DOCUMENT NO. SHEET NO. 5 OF 85
	SEE BOM TABLE	THIS DRAWING CONTAINS INFORMATION THAT IS PROPRIETARY TO MOLEX INCORPORATED AND SHOULD NOT BE USED WITHOUT WRITTEN PERMISSION				
	SIZE	INCORPORATED AND SHOULD NOT BE USED WITHOUT WRITTEN PERMISSION				

STATUS	GM PART #	MATERIAL #	PART/MATERIAL REVISION	WIRE DRESS OPTION	KEY OPTION	COLOR (TPA)	NUMBERS INDICATE CAVITIES OPEN FOR CIRCUITS																																																																																
AVAILABLE	NOT APPLICABLE	34566-2603	G	0	B	ST GRY	<table border="1"> <tr><td></td><td></td><td></td><td></td><td>67</td><td>66</td><td>65</td><td></td><td></td><td></td><td></td><td></td><td></td><td>59</td><td>57</td><td>55</td><td>53</td></tr> <tr><td></td><td></td><td>49</td><td>48</td><td>47</td><td></td><td></td><td>44</td><td></td><td></td><td></td><td></td><td></td><td>39</td><td>37</td><td>35</td><td>33</td></tr> <tr><td>73</td><td></td><td></td><td></td><td></td><td></td><td>29</td><td>28</td><td></td><td></td><td></td><td></td><td></td><td>23</td><td>21</td><td></td><td></td></tr> <tr><td></td><td></td><td></td><td></td><td></td><td></td><td></td><td></td><td></td><td></td><td></td><td></td><td></td><td>7</td><td></td><td></td><td></td></tr> </table>					67	66	65							59	57	55	53			49	48	47			44						39	37	35	33	73						29	28						23	21																7															
				67	66	65							59	57	55	53																																																																							
		49	48	47			44						39	37	35	33																																																																							
73						29	28						23	21																																																																									
													7																																																																										
AVAILABLE	NOT APPLICABLE	34566-2703	G	0	B	ST GRY	<table border="1"> <tr><td></td><td></td><td></td><td></td><td></td><td></td><td>65</td><td></td><td></td><td></td><td></td><td></td><td></td><td>59</td><td>57</td><td>55</td><td>53</td></tr> <tr><td></td><td></td><td>49</td><td>48</td><td>47</td><td></td><td></td><td>44</td><td></td><td></td><td></td><td></td><td></td><td>39</td><td>37</td><td>35</td><td>33</td></tr> <tr><td>73</td><td></td><td></td><td></td><td></td><td></td><td>29</td><td>28</td><td></td><td></td><td></td><td></td><td></td><td>23</td><td>21</td><td></td><td></td></tr> <tr><td></td><td></td><td></td><td></td><td></td><td></td><td></td><td></td><td></td><td></td><td></td><td></td><td></td><td>7</td><td></td><td></td><td></td></tr> </table>							65							59	57	55	53			49	48	47			44						39	37	35	33	73						29	28						23	21																7															
						65							59	57	55	53																																																																							
		49	48	47			44						39	37	35	33																																																																							
73						29	28						23	21																																																																									
													7																																																																										
AVAILABLE	NOT APPLICABLE	34566-2803	G	0	H	ST GRY	<table border="1"> <tr><td></td><td></td><td></td><td></td><td></td><td></td><td></td><td></td><td></td><td></td><td></td><td></td><td></td><td></td><td></td><td></td><td></td></tr> <tr><td></td><td></td><td></td><td></td><td></td><td></td><td></td><td></td><td></td><td></td><td></td><td></td><td></td><td></td><td></td><td></td><td></td></tr> <tr><td></td><td></td><td></td><td></td><td></td><td></td><td></td><td></td><td></td><td></td><td></td><td></td><td></td><td></td><td></td><td></td><td></td></tr> <tr><td></td><td></td><td></td><td></td><td></td><td></td><td></td><td></td><td></td><td></td><td></td><td></td><td></td><td></td><td></td><td></td><td></td></tr> </table>																																																																																
AVAILABLE	NOT APPLICABLE	34566-2903	G	0	A	BLACK	<table border="1"> <tr><td>72</td><td>71</td><td>70</td><td>69</td><td>68</td><td>67</td><td>66</td><td></td><td>64</td><td>63</td><td>62</td><td>61</td><td></td><td>59</td><td></td><td></td><td>55</td><td>54</td><td>53</td></tr> <tr><td>52</td><td>51</td><td></td><td>49</td><td>48</td><td></td><td></td><td></td><td>44</td><td>43</td><td>42</td><td>41</td><td></td><td>39</td><td></td><td></td><td></td><td>35</td><td>34</td><td>33</td></tr> <tr><td></td><td></td><td></td><td>32</td><td>31</td><td></td><td></td><td>29</td><td></td><td>27</td><td></td><td>25</td><td>24</td><td>23</td><td></td><td></td><td>19</td><td>18</td><td>17</td></tr> <tr><td>73</td><td></td><td></td><td></td><td>16</td><td></td><td></td><td>13</td><td>12</td><td>11</td><td></td><td>9</td><td>8</td><td>7</td><td>6</td><td>5</td><td>4</td><td>3</td><td>2</td><td>1</td></tr> </table>	72	71	70	69	68	67	66		64	63	62	61		59			55	54	53	52	51		49	48				44	43	42	41		39				35	34	33				32	31			29		27		25	24	23			19	18	17	73				16			13	12	11		9	8	7	6	5	4	3	2	1		
72	71	70	69	68	67	66		64	63	62	61		59			55	54	53																																																																					
52	51		49	48				44	43	42	41		39				35	34	33																																																																				
			32	31			29		27		25	24	23			19	18	17																																																																					
73				16			13	12	11		9	8	7	6	5	4	3	2	1																																																																				
AVAILABLE	NOT APPLICABLE	34566-3003	G	0	A	BLACK	<table border="1"> <tr><td>72</td><td>71</td><td>70</td><td>69</td><td>68</td><td>67</td><td>66</td><td></td><td>64</td><td>63</td><td>62</td><td></td><td>60</td><td>59</td><td>58</td><td>57</td><td>56</td><td>55</td><td>54</td><td>53</td></tr> <tr><td>52</td><td>51</td><td>50</td><td>49</td><td>48</td><td>47</td><td>46</td><td></td><td>44</td><td>43</td><td>42</td><td>41</td><td>40</td><td>39</td><td>38</td><td>37</td><td>36</td><td>35</td><td>34</td><td>33</td></tr> <tr><td></td><td></td><td></td><td>32</td><td>31</td><td>30</td><td>29</td><td>28</td><td>27</td><td></td><td>25</td><td>24</td><td>23</td><td>22</td><td>21</td><td>20</td><td>19</td><td>18</td><td>17</td><td></td></tr> <tr><td>73</td><td></td><td></td><td>16</td><td>15</td><td>14</td><td>13</td><td>12</td><td>11</td><td></td><td>9</td><td>8</td><td>7</td><td>6</td><td>5</td><td>4</td><td>3</td><td>2</td><td>1</td><td></td></tr> </table>	72	71	70	69	68	67	66		64	63	62		60	59	58	57	56	55	54	53	52	51	50	49	48	47	46		44	43	42	41	40	39	38	37	36	35	34	33				32	31	30	29	28	27		25	24	23	22	21	20	19	18	17		73			16	15	14	13	12	11		9	8	7	6	5	4	3	2	1	
72	71	70	69	68	67	66		64	63	62		60	59	58	57	56	55	54	53																																																																				
52	51	50	49	48	47	46		44	43	42	41	40	39	38	37	36	35	34	33																																																																				
			32	31	30	29	28	27		25	24	23	22	21	20	19	18	17																																																																					
73			16	15	14	13	12	11		9	8	7	6	5	4	3	2	1																																																																					
AVAILABLE	NOT APPLICABLE	34566-3103	G	0	B	ST GRY	<table border="1"> <tr><td></td><td></td><td></td><td></td><td></td><td></td><td>65</td><td></td><td></td><td></td><td></td><td></td><td></td><td>59</td><td>57</td><td>55</td><td>53</td></tr> <tr><td></td><td></td><td>49</td><td>48</td><td></td><td></td><td>46</td><td></td><td></td><td></td><td></td><td></td><td></td><td>39</td><td>37</td><td>35</td><td>33</td></tr> <tr><td>73</td><td></td><td></td><td></td><td></td><td></td><td>29</td><td></td><td></td><td></td><td>26</td><td></td><td></td><td>23</td><td>21</td><td></td><td>18</td></tr> <tr><td></td><td></td><td></td><td></td><td></td><td></td><td>15</td><td></td><td></td><td></td><td>9</td><td>8</td><td>7</td><td></td><td>4</td><td>3</td><td></td></tr> </table>							65							59	57	55	53			49	48			46							39	37	35	33	73						29				26			23	21		18							15				9	8	7		4	3													
						65							59	57	55	53																																																																							
		49	48			46							39	37	35	33																																																																							
73						29				26			23	21		18																																																																							
						15				9	8	7		4	3																																																																								
AVAILABLE	NOT APPLICABLE	34566-3203	G	0	B	ST GRY	<table border="1"> <tr><td></td><td></td><td></td><td></td><td>67</td><td></td><td></td><td></td><td></td><td></td><td></td><td></td><td></td><td>60</td><td>59</td><td>58</td><td>57</td><td>56</td><td>55</td><td>53</td></tr> <tr><td></td><td></td><td>50</td><td>49</td><td>48</td><td></td><td>46</td><td></td><td></td><td></td><td></td><td></td><td></td><td>39</td><td>38</td><td>37</td><td></td><td>35</td><td>34</td><td>33</td></tr> <tr><td>73</td><td></td><td></td><td></td><td></td><td></td><td>29</td><td></td><td></td><td></td><td></td><td></td><td></td><td>23</td><td>22</td><td>21</td><td></td><td>18</td><td></td><td></td></tr> <tr><td></td><td></td><td></td><td></td><td></td><td></td><td>16</td><td>15</td><td>14</td><td></td><td></td><td></td><td></td><td>7</td><td>6</td><td>5</td><td>4</td><td>3</td><td></td><td></td></tr> </table>					67									60	59	58	57	56	55	53			50	49	48		46							39	38	37		35	34	33	73						29							23	22	21		18									16	15	14					7	6	5	4	3		
				67									60	59	58	57	56	55	53																																																																				
		50	49	48		46							39	38	37		35	34	33																																																																				
73						29							23	22	21		18																																																																						
						16	15	14					7	6	5	4	3																																																																						
AVAILABLE	NOT APPLICABLE	34566-3303	G	0	B	ST GRY	<table border="1"> <tr><td></td><td></td><td></td><td></td><td>46</td><td></td><td></td><td></td><td></td><td></td><td></td><td></td><td></td><td>59</td><td>58</td><td>57</td><td>56</td><td>55</td><td>53</td></tr> <tr><td></td><td></td><td>50</td><td>49</td><td>48</td><td></td><td>46</td><td></td><td></td><td></td><td></td><td></td><td></td><td>39</td><td>38</td><td>37</td><td></td><td>35</td><td>34</td><td>33</td></tr> <tr><td>73</td><td></td><td></td><td></td><td></td><td></td><td>29</td><td></td><td></td><td></td><td></td><td></td><td></td><td>23</td><td>22</td><td>21</td><td></td><td>18</td><td></td><td></td></tr> <tr><td></td><td></td><td></td><td></td><td></td><td></td><td>16</td><td>15</td><td>14</td><td></td><td></td><td></td><td></td><td>7</td><td>6</td><td>5</td><td>4</td><td>3</td><td></td><td></td></tr> </table>					46									59	58	57	56	55	53			50	49	48		46							39	38	37		35	34	33	73						29							23	22	21		18									16	15	14					7	6	5	4	3			
				46									59	58	57	56	55	53																																																																					
		50	49	48		46							39	38	37		35	34	33																																																																				
73						29							23	22	21		18																																																																						
						16	15	14					7	6	5	4	3																																																																						
AVAILABLE	NOT APPLICABLE	34566-3403					SEE 34566-3003																																																																																
AVAILABLE	NOT APPLICABLE	34566-3503	G	0	A	BLACK	<table border="1"> <tr><td>72</td><td>71</td><td></td><td>69</td><td>68</td><td>67</td><td>66</td><td></td><td>64</td><td>63</td><td>62</td><td></td><td>60</td><td>59</td><td></td><td></td><td></td><td></td><td></td><td></td></tr> <tr><td>52</td><td></td><td></td><td>49</td><td>48</td><td></td><td>46</td><td></td><td>44</td><td>43</td><td>42</td><td></td><td>40</td><td>39</td><td></td><td></td><td></td><td></td><td>35</td><td>33</td></tr> <tr><td></td><td></td><td></td><td>32</td><td></td><td></td><td>29</td><td></td><td></td><td>27</td><td></td><td>24</td><td>23</td><td></td><td></td><td></td><td></td><td></td><td></td><td>17</td></tr> <tr><td>73</td><td></td><td></td><td></td><td></td><td></td><td>14</td><td>13</td><td>12</td><td>11</td><td></td><td>9</td><td>8</td><td>7</td><td>6</td><td>5</td><td>4</td><td>3</td><td>2</td><td>1</td></tr> </table>	72	71		69	68	67	66		64	63	62		60	59							52			49	48		46		44	43	42		40	39					35	33				32			29			27		24	23							17	73						14	13	12	11		9	8	7	6	5	4	3	2	1
72	71		69	68	67	66		64	63	62		60	59																																																																										
52			49	48		46		44	43	42		40	39					35	33																																																																				
			32			29			27		24	23							17																																																																				
73						14	13	12	11		9	8	7	6	5	4	3	2	1																																																																				

SEE NEXT PAGE FOR ADDITIONAL NUMBERS

ENTER DESCRIPTION EC NO: UAU2016-0232 DRAWN BY: CHKD CHCK: APPR: IKOSHY 2015/08/14 2015/08/14 REV:	QUALITY SYMBOLS	GENERAL TOLERANCES (UNLESS SPECIFIED)	DIMENSION STYLE	SCALE	DESIGN UNITS	THIRD ANGLE PROJECTION
	▽=0	4 PLACES ± mm INCH	MM ONLY		METRIC	
	▽=0	3 PLACES ±	DRAWN BY DATE			TITLE
	▽=0	2 PLACES ±	CHECKED BY DATE			
	1 PLACE ±	APPROVED BY DATE				
	0 PLACE ±					
	ANGULAR ±	DRAFT WHERE APPLICABLE MUST REMAIN WITHIN DIMENSIONS	MATERIAL NO.	DOCUMENT NO.		
			SEE BOM TABLE	SD-34566-001		
			THIS DRAWING CONTAINS INFORMATION THAT IS PROPRIETARY TO MOLEX INCORPORATED AND SHOULD NOT BE USED WITHOUT WRITTEN PERMISSION			

MX123
66/73/80CKT
HRNS CONN ASSY

molex

SHEET NO.
6 OF 85

STATUS	GM PART #	MATERIAL #	PART/ MATERIAL REVISION	WIRE DRESS OPTION	KEY OPTION ▽	COLOR (TPA) ▽	NUMBERS INDICATE CAVITIES OPEN FOR CIRCUITS ▽																																																																																
AVAILABLE	NOT APPLICABLE	34566-3603	G	0	B	ST GRY	<table border="1"> <tr><td></td><td></td><td></td><td></td><td>68</td><td></td><td></td><td></td><td>64</td><td></td><td></td><td></td><td></td><td>59</td><td>57</td><td>55</td><td>53</td></tr> <tr><td></td><td></td><td>49</td><td>48</td><td>46</td><td></td><td></td><td></td><td></td><td></td><td></td><td></td><td></td><td>39</td><td>37</td><td>35</td><td>33</td></tr> <tr><td>73</td><td></td><td>32</td><td></td><td>29</td><td></td><td></td><td></td><td></td><td></td><td></td><td></td><td></td><td>23</td><td>21</td><td></td><td>18</td></tr> <tr><td></td><td></td><td></td><td></td><td></td><td></td><td></td><td></td><td>11</td><td>10</td><td></td><td></td><td></td><td>7</td><td></td><td></td><td></td></tr> </table>					68				64					59	57	55	53			49	48	46									39	37	35	33	73		32		29									23	21		18									11	10				7															
				68				64					59	57	55	53																																																																							
		49	48	46									39	37	35	33																																																																							
73		32		29									23	21		18																																																																							
								11	10				7																																																																										
AVAILABLE	NOT APPLICABLE	34566-3703	G	0	A	BLACK	<table border="1"> <tr><td></td><td></td><td></td><td></td><td>68</td><td>67</td><td>66</td><td>65</td><td></td><td></td><td></td><td></td><td></td><td>59</td><td></td><td>55</td><td>53</td></tr> <tr><td></td><td></td><td>49</td><td>48</td><td>47</td><td></td><td></td><td>44</td><td></td><td></td><td></td><td></td><td></td><td>39</td><td></td><td>35</td><td>33</td></tr> <tr><td>73</td><td></td><td></td><td></td><td></td><td></td><td>29</td><td>28</td><td></td><td></td><td></td><td></td><td></td><td>23</td><td></td><td></td><td></td></tr> <tr><td></td><td></td><td></td><td></td><td></td><td></td><td></td><td></td><td></td><td></td><td></td><td></td><td></td><td>7</td><td></td><td></td><td></td></tr> </table>					68	67	66	65						59		55	53			49	48	47			44						39		35	33	73						29	28						23																	7															
				68	67	66	65						59		55	53																																																																							
		49	48	47			44						39		35	33																																																																							
73						29	28						23																																																																										
													7																																																																										
AVAILABLE	NOT APPLICABLE	34566-3803	G	0	A	BLACK	<table border="1"> <tr><td>72</td><td>71</td><td></td><td>69</td><td>68</td><td>67</td><td>66</td><td></td><td>64</td><td>63</td><td>62</td><td></td><td></td><td>59</td><td></td><td>56</td><td>53</td></tr> <tr><td></td><td></td><td>50</td><td></td><td>48</td><td>46</td><td>44</td><td>43</td><td>42</td><td></td><td></td><td></td><td></td><td>39</td><td></td><td>36</td><td>33</td></tr> <tr><td></td><td></td><td></td><td></td><td>32</td><td></td><td>30</td><td>29</td><td>27</td><td></td><td></td><td></td><td></td><td>23</td><td></td><td>20</td><td>17</td></tr> <tr><td>73</td><td></td><td></td><td></td><td></td><td></td><td>14</td><td>13</td><td>12</td><td>11</td><td>10</td><td>9</td><td>8</td><td></td><td>5</td><td>4</td><td>3</td><td>2</td><td>1</td></tr> </table>	72	71		69	68	67	66		64	63	62			59		56	53			50		48	46	44	43	42					39		36	33					32		30	29	27					23		20	17	73						14	13	12	11	10	9	8		5	4	3	2	1										
72	71		69	68	67	66		64	63	62			59		56	53																																																																							
		50		48	46	44	43	42					39		36	33																																																																							
				32		30	29	27					23		20	17																																																																							
73						14	13	12	11	10	9	8		5	4	3	2	1																																																																					
AVAILABLE	NOT APPLICABLE	34566-3903	G	0	B	ST GRY	<table border="1"> <tr><td></td><td></td><td></td><td></td><td></td><td></td><td></td><td></td><td>65</td><td></td><td></td><td></td><td></td><td>59</td><td>57</td><td>55</td><td>53</td></tr> <tr><td></td><td></td><td>49</td><td>48</td><td></td><td></td><td>46</td><td></td><td>44</td><td></td><td></td><td></td><td></td><td>39</td><td>37</td><td>35</td><td>33</td></tr> <tr><td>73</td><td></td><td></td><td></td><td></td><td></td><td></td><td></td><td>29</td><td>28</td><td></td><td></td><td></td><td>24</td><td>23</td><td>21</td><td></td><td></td></tr> <tr><td></td><td></td><td></td><td></td><td></td><td></td><td></td><td></td><td></td><td></td><td></td><td></td><td></td><td>7</td><td></td><td></td><td></td><td></td></tr> </table>									65					59	57	55	53			49	48			46		44					39	37	35	33	73								29	28				24	23	21																7														
								65					59	57	55	53																																																																							
		49	48			46		44					39	37	35	33																																																																							
73								29	28				24	23	21																																																																								
													7																																																																										
AVAILABLE	NOT APPLICABLE	34566-4003	G	0	B	ST GRY	<table border="1"> <tr><td></td><td></td><td></td><td></td><td></td><td>67</td><td>66</td><td></td><td>64</td><td>63</td><td></td><td></td><td></td><td>59</td><td>57</td><td>55</td><td>53</td></tr> <tr><td></td><td>50</td><td>49</td><td>48</td><td></td><td></td><td></td><td></td><td>43</td><td></td><td></td><td></td><td></td><td>39</td><td>37</td><td>35</td><td>33</td></tr> <tr><td>73</td><td></td><td></td><td>32</td><td></td><td></td><td>29</td><td>27</td><td></td><td></td><td></td><td></td><td>24</td><td>23</td><td>21</td><td></td><td>18</td></tr> <tr><td></td><td></td><td></td><td></td><td>15</td><td></td><td></td><td></td><td></td><td></td><td></td><td></td><td></td><td>7</td><td>6</td><td>5</td><td>4</td><td>3</td><td></td></tr> </table>						67	66		64	63				59	57	55	53		50	49	48					43					39	37	35	33	73			32			29	27					24	23	21		18					15									7	6	5	4	3											
					67	66		64	63				59	57	55	53																																																																							
	50	49	48					43					39	37	35	33																																																																							
73			32			29	27					24	23	21		18																																																																							
				15									7	6	5	4	3																																																																						
AVAILABLE	NOT APPLICABLE	34566-4103	G	0	A	BLACK	<table border="1"> <tr><td>72</td><td>71</td><td></td><td>69</td><td>68</td><td>67</td><td>66</td><td></td><td>64</td><td>63</td><td>62</td><td></td><td></td><td>60</td><td>59</td><td></td><td></td><td>35</td><td>33</td></tr> <tr><td>52</td><td></td><td>49</td><td>48</td><td>46</td><td>45</td><td>44</td><td>43</td><td>42</td><td></td><td></td><td></td><td></td><td>40</td><td>39</td><td></td><td></td><td></td><td></td></tr> <tr><td></td><td></td><td></td><td>32</td><td></td><td></td><td>29</td><td>27</td><td>26</td><td></td><td></td><td></td><td></td><td>24</td><td>23</td><td></td><td></td><td></td><td>17</td></tr> <tr><td>73</td><td></td><td></td><td></td><td></td><td></td><td>14</td><td>13</td><td>12</td><td>11</td><td>10</td><td>9</td><td>8</td><td>7</td><td>6</td><td>5</td><td>4</td><td>3</td><td>2</td><td>1</td></tr> </table>	72	71		69	68	67	66		64	63	62			60	59			35	33	52		49	48	46	45	44	43	42					40	39								32			29	27	26					24	23				17	73						14	13	12	11	10	9	8	7	6	5	4	3	2	1			
72	71		69	68	67	66		64	63	62			60	59			35	33																																																																					
52		49	48	46	45	44	43	42					40	39																																																																									
			32			29	27	26					24	23				17																																																																					
73						14	13	12	11	10	9	8	7	6	5	4	3	2	1																																																																				
AVAILABLE	NOT APPLICABLE	34566-4203	G	0	B	ST GRY	<table border="1"> <tr><td></td><td></td><td></td><td></td><td></td><td></td><td></td><td></td><td>64</td><td></td><td></td><td></td><td></td><td>59</td><td>57</td><td>55</td><td>53</td></tr> <tr><td></td><td></td><td>50</td><td>49</td><td>48</td><td></td><td></td><td></td><td>46</td><td></td><td></td><td></td><td></td><td>39</td><td>37</td><td>35</td><td>33</td></tr> <tr><td>73</td><td></td><td></td><td></td><td>32</td><td></td><td></td><td></td><td>29</td><td></td><td></td><td></td><td></td><td>24</td><td>23</td><td>21</td><td></td><td>18</td></tr> <tr><td></td><td></td><td></td><td></td><td></td><td>15</td><td></td><td></td><td></td><td></td><td></td><td></td><td></td><td>7</td><td>6</td><td>5</td><td>4</td><td>3</td><td></td></tr> </table>									64					59	57	55	53			50	49	48				46					39	37	35	33	73				32				29					24	23	21		18						15								7	6	5	4	3										
								64					59	57	55	53																																																																							
		50	49	48				46					39	37	35	33																																																																							
73				32				29					24	23	21		18																																																																						
					15								7	6	5	4	3																																																																						
AVAILABLE	NOT APPLICABLE	34566-4303	G	0	A	BLACK	<table border="1"> <tr><td></td><td></td><td>70</td><td>69</td><td>68</td><td>67</td><td></td><td>65</td><td>64</td><td>63</td><td></td><td>61</td><td>59</td><td>58</td><td>57</td><td>56</td><td></td><td></td><td></td><td></td></tr> <tr><td></td><td></td><td>50</td><td>49</td><td>48</td><td>47</td><td></td><td></td><td></td><td></td><td></td><td>41</td><td></td><td>38</td><td>37</td><td>36</td><td></td><td>34</td><td>33</td><td></td></tr> <tr><td></td><td></td><td></td><td>32</td><td>31</td><td>30</td><td>29</td><td>28</td><td>27</td><td></td><td></td><td></td><td>24</td><td>23</td><td></td><td></td><td>20</td><td>19</td><td>18</td><td></td></tr> <tr><td>73</td><td></td><td></td><td></td><td></td><td>16</td><td></td><td></td><td></td><td></td><td></td><td></td><td></td><td></td><td></td><td></td><td></td><td></td><td></td><td>1</td></tr> </table>			70	69	68	67		65	64	63		61	59	58	57	56							50	49	48	47						41		38	37	36		34	33					32	31	30	29	28	27				24	23			20	19	18		73					16														1
		70	69	68	67		65	64	63		61	59	58	57	56																																																																								
		50	49	48	47						41		38	37	36		34	33																																																																					
			32	31	30	29	28	27				24	23			20	19	18																																																																					
73					16														1																																																																				

SEE NEXT PAGE FOR ADDITIONAL NUMBERS

ENTER DESCRIPTION EC NO: UAU2016-0232 DRAWN BY: 2015/08/14 CHKD: 2015/08/14 APPR: WOSHY G34	QUALITY SYMBOLS ▽=0 ▽=0 ▽=0	GENERAL TOLERANCES (UNLESS SPECIFIED) mm INCH 4 PLACES ±--- ±--- 3 PLACES ±--- ±--- 2 PLACES ±--- ±--- 1 PLACE ±--- ±--- 0 PLACE ±--- ±--- ANGULAR ±---° DRAFT WHERE APPLICABLE MUST REMAIN WITHIN DIMENSIONS	DIMENSION STYLE MM ONLY DRAWN BY: SKRA JENDRANA 2011/02/14 CHECKED BY: MVANSLAMBROU 2011/02/14 APPROVED BY:	SCALE METRIC	DESIGN UNITS METRIC	THIRD ANGLE PROJECTION
	TITLE MX123 66/73/80CKT HRNS CONN ASSY			MATERIAL NO. DOCUMENT NO.		SHEET NO.
	SEE BOM TABLE			SD-34566-001		7 OF 85
	THIS DRAWING CONTAINS INFORMATION THAT IS PROPRIETARY TO MOLEX INCORPORATED AND SHOULD NOT BE USED WITHOUT WRITTEN PERMISSION					

STATUS	GM PART #	MATERIAL #	PART/MATERIAL REVISION	WIRE DRESS OPTION	KEY OPTION	COLOR (TPA)	NUMBERS INDICATE CAVITIES OPEN FOR CIRCUITS																							
AVAILABLE	NOT APPLICABLE	34566-5203	G	0	A	BLACK	72	71	69	68	67	66	64	63	62	59	58	57	56	54	53									
							52	51	50	49	48	47	46	44	43	42	39	38	37	36	35	34	33							
							73			32	31	30	29	27		24	23	22	21	20	19	17								
																9	8	7	6	5	4	3	2	1						
AVAILABLE	NOT APPLICABLE	34566-5303	G	0	B	ST GRY										65	64				59	57	55	53						
										50	49	48	46								39	37	35	33						
							73														23	21								
																					7	6	5	4	3	2	1			
AVAILABLE	NOT APPLICABLE	34566-5403	G	0	B	ST GRY															65			59	58	57	56	55	53	
										50	49	48	46	45							39	38	37	35	34	33				
							73														29							18		
																					16	15	14							
AVAILABLE	NOT APPLICABLE	34566-5503	G	0	A	BLACK	72	71	69	68	67	66	64	63	62	60	59													
							52		49	48	46	44	43	42	40	39							35	33						
							73														32								17	
AVAILABLE	NOT APPLICABLE	34566-5603	SEE 34566-2503																											
AVAILABLE	NOT APPLICABLE	34566-5703	G	0	B	ST GRY															68			59	57	55	53			
																					49	48	46				39	37	35	33
							73																							17
AVAILABLE	NOT APPLICABLE	34566-5803	G	0	B	ST GRY																								
																					49	48	47				59	57	55	53
							73																							
AVAILABLE	NOT APPLICABLE	34566-5903	G	0	A	BLACK	72	71	69	68	67	66	64	63	62	59														
							73																							

SEE NEXT PAGE FOR ADDITIONAL NUMBERS

ENTER DESCRIPTION EC NO: UAU2016-0232 DRAWN BY CHKD: APPR:KOSHY REV:	2015/08/14 2015/08/14	QUALITY SYMBOLS ∇=0 ∇=0 ∇=0	GENERAL TOLERANCES (UNLESS SPECIFIED): mm INCH 4 PLACES ± --- ± --- 3 PLACES ± --- ± --- 2 PLACES ± --- ± --- 1 PLACE ± --- ± --- 0 PLACE ± --- ± ---	DIMENSION STYLE MM ONLY	SCALE DESIGN UNITS METRIC	THIRD ANGLE PROJECTION
	DRAWN BY SKRAJENDRANA 2011/02/14	DATE 2011/02/14	CHECKED BY MVANSLAMBROU 2011/02/14	DATE 2011/02/14	APPROVED BY DATE	TITLE MX123 66/73/80CKT HRNS CONN ASSY
	MATERIAL NO. SEE BOM TABLE	DOCUMENT NO. SD-34566-001	SHEET NO. 9 OF 85	THIS DRAWING CONTAINS INFORMATION THAT IS PROPRIETARY TO MOLEX INCORPORATED AND SHOULD NOT BE USED WITHOUT WRITTEN PERMISSION		
	DRAFT WHERE APPLICABLE MUST REMAIN WITHIN DIMENSIONS					

STATUS	GM PART #	MATERIAL #	PART/MATERIAL REVISION	WIRE DRESS OPTION	KEY OPTION	COLOR (TPA)	NUMBERS INDICATE CAVITIES OPEN FOR CIRCUITS																																																																																				
AVAILABLE	NOT APPLICABLE	34566-6003	G	0	B	ST GRAY	<table border="1"> <tr><td></td><td></td><td></td><td></td><td>67</td><td>66</td><td>65</td><td></td><td></td><td></td><td></td><td></td><td></td><td>59</td><td>57</td><td>55</td><td>53</td></tr> <tr><td></td><td></td><td>49</td><td>48</td><td>47</td><td></td><td></td><td></td><td></td><td></td><td></td><td></td><td></td><td>39</td><td>37</td><td>35</td><td>33</td></tr> <tr><td>73</td><td></td><td></td><td></td><td></td><td></td><td></td><td></td><td></td><td></td><td></td><td></td><td></td><td>23</td><td>21</td><td></td><td></td></tr> <tr><td></td><td></td><td></td><td></td><td></td><td></td><td></td><td></td><td></td><td></td><td></td><td></td><td></td><td>7</td><td></td><td></td><td></td></tr> </table>					67	66	65							59	57	55	53			49	48	47									39	37	35	33	73													23	21																7																			
				67	66	65							59	57	55	53																																																																											
		49	48	47									39	37	35	33																																																																											
73													23	21																																																																													
													7																																																																														
AVAILABLE	NOT APPLICABLE	34566-6103	G	0	B	ST GRAY	<table border="1"> <tr><td></td><td></td><td></td><td></td><td>67</td><td>66</td><td>65</td><td></td><td></td><td></td><td></td><td></td><td></td><td>59</td><td>57</td><td>55</td><td>53</td></tr> <tr><td></td><td></td><td>49</td><td>48</td><td>47</td><td></td><td></td><td></td><td></td><td></td><td></td><td></td><td>42</td><td>39</td><td>37</td><td>35</td><td>33</td></tr> <tr><td>73</td><td></td><td></td><td></td><td></td><td></td><td></td><td></td><td></td><td></td><td></td><td></td><td></td><td>23</td><td>21</td><td></td><td></td></tr> <tr><td></td><td></td><td></td><td></td><td></td><td></td><td></td><td></td><td></td><td></td><td></td><td></td><td>9</td><td>7</td><td></td><td></td><td></td></tr> </table>					67	66	65							59	57	55	53			49	48	47								42	39	37	35	33	73													23	21															9	7																			
				67	66	65							59	57	55	53																																																																											
		49	48	47								42	39	37	35	33																																																																											
73													23	21																																																																													
												9	7																																																																														
AVAILABLE	NOT APPLICABLE	34566-6203	G	0	A	BLACK	<table border="1"> <tr><td></td><td>71</td><td>70</td><td>69</td><td>68</td><td></td><td></td><td></td><td>65</td><td>64</td><td>63</td><td></td><td>61</td><td>59</td><td>57</td><td>56</td><td></td><td></td></tr> <tr><td>52</td><td>51</td><td>50</td><td>49</td><td>47</td><td></td><td></td><td></td><td></td><td></td><td></td><td></td><td>41</td><td></td><td></td><td>38</td><td>37</td><td>36</td><td>34</td><td>33</td></tr> <tr><td>73</td><td></td><td></td><td></td><td></td><td></td><td></td><td></td><td></td><td></td><td></td><td></td><td></td><td></td><td></td><td>24</td><td>23</td><td></td><td>20</td><td>19</td><td>18</td></tr> <tr><td></td><td></td><td></td><td></td><td></td><td></td><td></td><td></td><td></td><td></td><td></td><td></td><td></td><td></td><td></td><td></td><td></td><td></td><td></td><td></td><td>1</td></tr> </table>		71	70	69	68				65	64	63		61	59	57	56			52	51	50	49	47								41			38	37	36	34	33	73															24	23		20	19	18																					1				
	71	70	69	68				65	64	63		61	59	57	56																																																																												
52	51	50	49	47								41			38	37	36	34	33																																																																								
73															24	23		20	19	18																																																																							
																				1																																																																							
AVAILABLE	NOT APPLICABLE	34566-6303	G	0	A	BLACK	<table border="1"> <tr><td></td><td>71</td><td>70</td><td>69</td><td>68</td><td></td><td></td><td></td><td>65</td><td>64</td><td>63</td><td></td><td>61</td><td>59</td><td>57</td><td>56</td><td></td><td></td></tr> <tr><td>52</td><td>51</td><td>50</td><td>49</td><td>47</td><td></td><td></td><td></td><td></td><td></td><td></td><td></td><td>41</td><td></td><td></td><td>38</td><td>37</td><td>36</td><td>34</td><td>33</td></tr> <tr><td>73</td><td></td><td></td><td></td><td></td><td></td><td></td><td></td><td></td><td></td><td></td><td></td><td></td><td></td><td></td><td>20</td><td>19</td><td>18</td><td></td><td></td><td>1</td></tr> <tr><td></td><td></td><td></td><td></td><td></td><td></td><td></td><td></td><td></td><td></td><td></td><td></td><td></td><td></td><td></td><td></td><td></td><td></td><td></td><td></td><td></td></tr> </table>		71	70	69	68				65	64	63		61	59	57	56			52	51	50	49	47								41			38	37	36	34	33	73															20	19	18			1																									
	71	70	69	68				65	64	63		61	59	57	56																																																																												
52	51	50	49	47								41			38	37	36	34	33																																																																								
73															20	19	18			1																																																																							
AVAILABLE	NOT APPLICABLE	34566-6403	G	0	A	BLACK	<table border="1"> <tr><td></td><td>71</td><td></td><td>69</td><td>68</td><td></td><td></td><td></td><td>65</td><td>64</td><td>63</td><td></td><td>61</td><td>59</td><td>58</td><td>56</td><td></td><td></td></tr> <tr><td>52</td><td></td><td>50</td><td>49</td><td>47</td><td></td><td></td><td></td><td></td><td></td><td></td><td></td><td>41</td><td></td><td></td><td>38</td><td>37</td><td>36</td><td>34</td><td>33</td></tr> <tr><td>73</td><td></td><td></td><td></td><td></td><td></td><td></td><td></td><td></td><td></td><td></td><td></td><td></td><td></td><td></td><td>20</td><td>19</td><td>18</td><td>17</td><td></td><td>1</td></tr> <tr><td></td><td></td><td></td><td></td><td></td><td></td><td></td><td></td><td></td><td></td><td></td><td></td><td></td><td></td><td></td><td></td><td></td><td></td><td></td><td></td><td></td></tr> </table>		71		69	68				65	64	63		61	59	58	56			52		50	49	47								41			38	37	36	34	33	73															20	19	18	17		1																									
	71		69	68				65	64	63		61	59	58	56																																																																												
52		50	49	47								41			38	37	36	34	33																																																																								
73															20	19	18	17		1																																																																							
AVAILABLE	NOT APPLICABLE	34566-6503	G	0	A	BLACK	<table border="1"> <tr><td></td><td>71</td><td></td><td>69</td><td>68</td><td></td><td></td><td></td><td>65</td><td>64</td><td>63</td><td></td><td>61</td><td>59</td><td>58</td><td>56</td><td></td><td></td></tr> <tr><td>52</td><td></td><td>50</td><td>49</td><td>47</td><td></td><td></td><td></td><td></td><td></td><td></td><td></td><td>41</td><td></td><td></td><td>38</td><td>37</td><td>36</td><td>34</td><td>33</td></tr> <tr><td>73</td><td></td><td></td><td></td><td></td><td></td><td></td><td></td><td></td><td></td><td></td><td></td><td></td><td></td><td></td><td>20</td><td>19</td><td>18</td><td>17</td><td></td><td>1</td></tr> <tr><td></td><td></td><td></td><td></td><td></td><td></td><td></td><td></td><td></td><td></td><td></td><td></td><td></td><td></td><td></td><td></td><td></td><td></td><td></td><td></td><td></td></tr> </table>		71		69	68				65	64	63		61	59	58	56			52		50	49	47								41			38	37	36	34	33	73															20	19	18	17		1																									
	71		69	68				65	64	63		61	59	58	56																																																																												
52		50	49	47								41			38	37	36	34	33																																																																								
73															20	19	18	17		1																																																																							
AVAILABLE	NOT APPLICABLE	34566-6603	G	0	H	ST GRAY	<table border="1"> <tr><td></td><td>79</td><td>78</td><td>77</td><td>76</td><td>75</td><td>74</td><td>73</td><td>72</td><td>71</td><td>70</td><td>69</td><td>68</td><td></td><td>66</td><td>65</td><td>64</td><td>63</td><td>61</td><td></td><td></td></tr> <tr><td>60</td><td>59</td><td>58</td><td>57</td><td>56</td><td></td><td></td><td>53</td><td>52</td><td>50</td><td></td><td></td><td></td><td></td><td></td><td></td><td>44</td><td>43</td><td>41</td><td></td><td></td></tr> <tr><td>40</td><td>39</td><td>38</td><td>37</td><td></td><td>35</td><td>34</td><td>33</td><td>32</td><td>30</td><td>29</td><td></td><td></td><td>27</td><td>26</td><td></td><td></td><td></td><td>22</td><td>21</td><td></td></tr> <tr><td>20</td><td>19</td><td>18</td><td>17</td><td>16</td><td></td><td></td><td>13</td><td>12</td><td>11</td><td>10</td><td>9</td><td>8</td><td>6</td><td>5</td><td></td><td></td><td>3</td><td>2</td><td></td><td></td></tr> </table>		79	78	77	76	75	74	73	72	71	70	69	68		66	65	64	63	61			60	59	58	57	56			53	52	50							44	43	41			40	39	38	37		35	34	33	32	30	29			27	26				22	21		20	19	18	17	16			13	12	11	10	9	8	6	5			3	2		
	79	78	77	76	75	74	73	72	71	70	69	68		66	65	64	63	61																																																																									
60	59	58	57	56			53	52	50							44	43	41																																																																									
40	39	38	37		35	34	33	32	30	29			27	26				22	21																																																																								
20	19	18	17	16			13	12	11	10	9	8	6	5			3	2																																																																									
AVAILABLE	NOT APPLICABLE	34566-6703	G	0	H	ST GRAY	<table border="1"> <tr><td></td><td>79</td><td>78</td><td>77</td><td>76</td><td>75</td><td>74</td><td>73</td><td>72</td><td>71</td><td>70</td><td>69</td><td>68</td><td></td><td>66</td><td>65</td><td>64</td><td>63</td><td>61</td><td></td><td></td></tr> <tr><td>60</td><td>59</td><td>58</td><td>57</td><td>56</td><td></td><td></td><td>53</td><td></td><td>50</td><td></td><td></td><td></td><td></td><td></td><td></td><td>44</td><td>43</td><td>41</td><td></td><td></td></tr> <tr><td>40</td><td>39</td><td>38</td><td>37</td><td></td><td>35</td><td>34</td><td>33</td><td>32</td><td>30</td><td>29</td><td></td><td></td><td>27</td><td>26</td><td></td><td></td><td></td><td>22</td><td>21</td><td></td></tr> <tr><td>20</td><td>19</td><td>18</td><td>17</td><td></td><td></td><td>14</td><td>13</td><td>12</td><td>11</td><td>10</td><td>9</td><td>8</td><td>6</td><td>5</td><td></td><td></td><td>3</td><td>2</td><td></td><td></td></tr> </table>		79	78	77	76	75	74	73	72	71	70	69	68		66	65	64	63	61			60	59	58	57	56			53		50							44	43	41			40	39	38	37		35	34	33	32	30	29			27	26				22	21		20	19	18	17			14	13	12	11	10	9	8	6	5			3	2		
	79	78	77	76	75	74	73	72	71	70	69	68		66	65	64	63	61																																																																									
60	59	58	57	56			53		50							44	43	41																																																																									
40	39	38	37		35	34	33	32	30	29			27	26				22	21																																																																								
20	19	18	17			14	13	12	11	10	9	8	6	5			3	2																																																																									

SEE NEXT PAGE FOR ADDITIONAL NUMBERS

ENTER DESCRIPTION EC NO: UAU2016-0232 DRAWN BY: 2015/08/14 CHKD: 2015/08/14 APPR: IKOSHY 2015/08/14 REV: GJ34	QUALITY SYMBOLS ∇=0 ∇=0 ∇=0	GENERAL TOLERANCES (UNLESS SPECIFIED) mm INCH 4 PLACES ± --- ± --- 3 PLACES ± --- ± --- 2 PLACES ± --- ± --- 1 PLACE ± --- ± --- 0 PLACE ± --- ± ---	DIMENSION STYLE MM ONLY	SCALE DESIGN UNITS METRIC	THIRD ANGLE PROJECTION
	DRAFT WHERE APPLICABLE MUST REMAIN WITHIN DIMENSIONS		DRAWN BY: SKRAJENDRANA 2011/02/14 CHECKED BY: MYANSLAMBROU 2011/02/14 APPROVED BY:	TITLE MX123 66/73/80CKT HRNS CONN ASSY	MATERIAL NO. SD-34566-001
	ANGULAR ± ---°		SEE BOM TABLE	DOCUMENT NO.	SHEET NO. 10 OF 85
	THIS DRAWING CONTAINS INFORMATION THAT IS PROPRIETARY TO MOLEX INCORPORATED AND SHOULD NOT BE USED WITHOUT WRITTEN PERMISSION				

STATUS	GM PART #	MATERIAL #	PART/MATERIAL REVISION	WIRE DRESS OPTION	KEY OPTION	COLOR (TPA)	NUMBERS INDICATE CAVITIES OPEN FOR CIRCUITS																																																																																																		
AVAILABLE	NOT APPLICABLE	34566-7603	G	0	B	ST GRAY	<table border="1"> <tr><td></td><td></td><td>69</td><td>68</td><td>66</td><td></td><td></td><td></td><td></td><td></td><td></td><td></td><td></td><td></td><td>59</td><td>57</td><td>55</td><td>53</td></tr> <tr><td></td><td></td><td>49</td><td>48</td><td>46</td><td>44</td><td></td><td></td><td></td><td></td><td></td><td></td><td></td><td></td><td>39</td><td>37</td><td>35</td><td>33</td></tr> <tr><td>73</td><td></td><td></td><td></td><td></td><td>29</td><td>28</td><td></td><td></td><td></td><td></td><td></td><td></td><td></td><td>23</td><td>21</td><td></td><td>18</td><td>17</td></tr> <tr><td></td><td></td><td></td><td></td><td></td><td>12</td><td>11</td><td>10</td><td></td><td></td><td></td><td></td><td></td><td></td><td>7</td><td></td><td></td><td></td><td></td></tr> </table>																		69	68	66										59	57	55	53			49	48	46	44									39	37	35	33	73					29	28								23	21		18	17						12	11	10							7													
		69	68	66										59	57	55	53																																																																																								
		49	48	46	44									39	37	35	33																																																																																								
73					29	28								23	21		18	17																																																																																							
					12	11	10							7																																																																																											
AVAILABLE	NOT APPLICABLE	34566-7703	G	0	A	BLACK	<table border="1"> <tr><td>72</td><td>71</td><td>70</td><td>69</td><td>68</td><td>67</td><td>66</td><td>64</td><td>63</td><td>62</td><td>60</td><td>59</td><td></td><td></td><td></td><td></td><td>55</td><td>54</td><td>53</td></tr> <tr><td>52</td><td></td><td>49</td><td>48</td><td></td><td></td><td></td><td>44</td><td>43</td><td>42</td><td>40</td><td>39</td><td></td><td></td><td></td><td></td><td>35</td><td>34</td><td>33</td></tr> <tr><td></td><td></td><td></td><td>32</td><td></td><td></td><td>29</td><td>27</td><td></td><td></td><td>24</td><td>23</td><td></td><td></td><td></td><td></td><td>19</td><td>18</td><td>17</td></tr> <tr><td>73</td><td></td><td></td><td>16</td><td></td><td></td><td>13</td><td>12</td><td>11</td><td>9</td><td>8</td><td>7</td><td>6</td><td>5</td><td>4</td><td>3</td><td>2</td><td>1</td><td></td></tr> </table>																72	71	70	69	68	67	66	64	63	62	60	59					55	54	53	52		49	48				44	43	42	40	39					35	34	33				32			29	27			24	23					19	18	17	73			16			13	12	11	9	8	7	6	5	4	3	2	1								
72	71	70	69	68	67	66	64	63	62	60	59					55	54	53																																																																																							
52		49	48				44	43	42	40	39					35	34	33																																																																																							
			32			29	27			24	23					19	18	17																																																																																							
73			16			13	12	11	9	8	7	6	5	4	3	2	1																																																																																								
AVAILABLE	NOT APPLICABLE	34566-7803	G	0	A	BLACK	<table border="1"> <tr><td>72</td><td>71</td><td>70</td><td></td><td>68</td><td></td><td>66</td><td>64</td><td>63</td><td>62</td><td>61</td><td>60</td><td>59</td><td></td><td></td><td></td><td>55</td><td>54</td><td>53</td></tr> <tr><td>52</td><td></td><td>49</td><td>48</td><td></td><td>46</td><td></td><td>44</td><td>43</td><td>42</td><td>40</td><td>39</td><td></td><td></td><td></td><td></td><td>35</td><td>34</td><td>33</td></tr> <tr><td></td><td></td><td></td><td>32</td><td></td><td></td><td>29</td><td>28</td><td>27</td><td></td><td>24</td><td>23</td><td></td><td></td><td></td><td></td><td>19</td><td>18</td><td>17</td></tr> <tr><td>73</td><td></td><td></td><td>16</td><td></td><td>14</td><td>13</td><td>12</td><td>11</td><td>9</td><td>8</td><td>7</td><td>6</td><td></td><td></td><td>3</td><td>2</td><td>1</td><td></td></tr> </table>																72	71	70		68		66	64	63	62	61	60	59				55	54	53	52		49	48		46		44	43	42	40	39					35	34	33				32			29	28	27		24	23					19	18	17	73			16		14	13	12	11	9	8	7	6			3	2	1								
72	71	70		68		66	64	63	62	61	60	59				55	54	53																																																																																							
52		49	48		46		44	43	42	40	39					35	34	33																																																																																							
			32			29	28	27		24	23					19	18	17																																																																																							
73			16		14	13	12	11	9	8	7	6			3	2	1																																																																																								
AVAILABLE	NOT APPLICABLE	34566-7903	G	0	B	ST GRAY	<table border="1"> <tr><td></td><td></td><td></td><td></td><td></td><td></td><td></td><td>64</td><td></td><td></td><td>61</td><td>59</td><td>57</td><td></td><td></td><td>55</td><td>53</td><td></td><td></td></tr> <tr><td></td><td></td><td></td><td></td><td></td><td></td><td></td><td></td><td></td><td></td><td>42</td><td>39</td><td></td><td></td><td></td><td>35</td><td>33</td><td></td><td></td></tr> <tr><td>73</td><td></td><td></td><td></td><td></td><td></td><td></td><td></td><td></td><td></td><td></td><td>23</td><td></td><td></td><td></td><td>20</td><td>19</td><td></td><td></td></tr> <tr><td></td><td></td><td></td><td></td><td></td><td>15</td><td></td><td></td><td></td><td></td><td></td><td></td><td></td><td></td><td></td><td>4</td><td>3</td><td>2</td><td>1</td></tr> </table>																							64			61	59	57			55	53													42	39				35	33			73											23				20	19								15										4	3	2	1							
							64			61	59	57			55	53																																																																																									
										42	39				35	33																																																																																									
73											23				20	19																																																																																									
					15										4	3	2	1																																																																																							
AVAILABLE	NOT APPLICABLE	34566-8003	G	0	A	BLACK	<table border="1"> <tr><td></td><td></td><td>69</td><td>68</td><td></td><td></td><td>65</td><td>64</td><td>63</td><td>61</td><td>60</td><td>59</td><td>58</td><td></td><td>56</td><td></td><td></td><td></td><td></td></tr> <tr><td>52</td><td>50</td><td>49</td><td>48</td><td>47</td><td></td><td></td><td></td><td></td><td>41</td><td></td><td></td><td></td><td></td><td>38</td><td>37</td><td>36</td><td></td><td>34</td><td>33</td></tr> <tr><td></td><td></td><td></td><td>32</td><td>31</td><td>30</td><td>29</td><td>28</td><td>27</td><td></td><td>24</td><td>23</td><td></td><td></td><td></td><td></td><td>20</td><td>19</td><td>18</td><td>17</td></tr> <tr><td>73</td><td></td><td></td><td>16</td><td></td><td></td><td>13</td><td>12</td><td>11</td><td>10</td><td>9</td><td></td><td></td><td></td><td></td><td></td><td></td><td></td><td></td><td>1</td></tr> </table>																		69	68			65	64	63	61	60	59	58		56					52	50	49	48	47					41					38	37	36		34	33				32	31	30	29	28	27		24	23					20	19	18	17	73			16			13	12	11	10	9									1				
		69	68			65	64	63	61	60	59	58		56																																																																																											
52	50	49	48	47					41					38	37	36		34	33																																																																																						
			32	31	30	29	28	27		24	23					20	19	18	17																																																																																						
73			16			13	12	11	10	9									1																																																																																						
AVAILABLE	NOT APPLICABLE	34566-8103	G	0	H	ST GRAY	<table border="1"> <tr><td></td><td></td><td>78</td><td></td><td></td><td></td><td></td><td>72</td><td>71</td><td>70</td><td>69</td><td>68</td><td></td><td>66</td><td>65</td><td>64</td><td>63</td><td></td><td>61</td></tr> <tr><td>60</td><td>59</td><td>58</td><td>57</td><td>56</td><td></td><td></td><td>53</td><td>52</td><td>50</td><td></td><td></td><td></td><td></td><td></td><td>44</td><td>43</td><td></td><td>41</td></tr> <tr><td>40</td><td></td><td></td><td>37</td><td>35</td><td>34</td><td>33</td><td>32</td><td></td><td>30</td><td>29</td><td></td><td>27</td><td>26</td><td></td><td>24</td><td></td><td></td><td>22</td><td>21</td></tr> <tr><td>20</td><td>19</td><td>18</td><td>17</td><td>16</td><td></td><td></td><td>13</td><td>12</td><td></td><td></td><td></td><td>8</td><td>6</td><td>5</td><td></td><td>3</td><td>2</td><td></td><td></td></tr> </table>																		78					72	71	70	69	68		66	65	64	63		61	60	59	58	57	56			53	52	50						44	43		41	40			37	35	34	33	32		30	29		27	26		24			22	21	20	19	18	17	16			13	12				8	6	5		3	2							
		78					72	71	70	69	68		66	65	64	63		61																																																																																							
60	59	58	57	56			53	52	50						44	43		41																																																																																							
40			37	35	34	33	32		30	29		27	26		24			22	21																																																																																						
20	19	18	17	16			13	12				8	6	5		3	2																																																																																								
AVAILABLE	NOT APPLICABLE	34566-8203	G	0	A	BLACK	<table border="1"> <tr><td></td><td></td><td>70</td><td></td><td></td><td>67</td><td>66</td><td></td><td></td><td></td><td></td><td></td><td></td><td></td><td>58</td><td>56</td><td>55</td><td>54</td><td></td><td></td></tr> <tr><td></td><td></td><td></td><td></td><td></td><td>47</td><td></td><td>44</td><td>43</td><td>42</td><td>41</td><td>39</td><td></td><td></td><td>37</td><td>36</td><td></td><td>34</td><td></td><td></td></tr> <tr><td>73</td><td></td><td></td><td></td><td></td><td>31</td><td>30</td><td></td><td></td><td>27</td><td>25</td><td>24</td><td></td><td></td><td>21</td><td>20</td><td>19</td><td>18</td><td></td><td></td></tr> <tr><td></td><td></td><td></td><td></td><td></td><td></td><td></td><td>13</td><td></td><td></td><td></td><td></td><td></td><td></td><td>6</td><td>5</td><td>4</td><td>3</td><td>2</td><td>1</td></tr> </table>																		70			67	66								58	56	55	54								47		44	43	42	41	39			37	36		34			73					31	30			27	25	24			21	20	19	18										13							6	5	4	3	2	1			
		70			67	66								58	56	55	54																																																																																								
					47		44	43	42	41	39			37	36		34																																																																																								
73					31	30			27	25	24			21	20	19	18																																																																																								
							13							6	5	4	3	2	1																																																																																						
AVAILABLE	NOT APPLICABLE	34566-8303	G	0	A	BLACK	<table border="1"> <tr><td>72</td><td>71</td><td>69</td><td>68</td><td>67</td><td>66</td><td>64</td><td>63</td><td>62</td><td></td><td></td><td>59</td><td>58</td><td>57</td><td>56</td><td></td><td>54</td><td>53</td><td></td><td></td></tr> <tr><td>52</td><td>51</td><td>50</td><td>49</td><td>48</td><td>47</td><td>46</td><td>44</td><td>43</td><td>42</td><td></td><td></td><td>39</td><td>38</td><td>37</td><td>36</td><td>35</td><td>34</td><td>33</td><td></td><td></td></tr> <tr><td></td><td></td><td></td><td>32</td><td>31</td><td>30</td><td>29</td><td></td><td>27</td><td></td><td></td><td>24</td><td>23</td><td>22</td><td>21</td><td>20</td><td>19</td><td></td><td>17</td><td></td><td></td></tr> <tr><td>73</td><td></td><td></td><td></td><td></td><td>15</td><td>14</td><td>13</td><td>12</td><td>11</td><td>9</td><td>8</td><td>7</td><td>6</td><td>5</td><td>4</td><td>3</td><td>2</td><td>1</td><td></td><td></td></tr> </table>																72	71	69	68	67	66	64	63	62			59	58	57	56		54	53			52	51	50	49	48	47	46	44	43	42			39	38	37	36	35	34	33						32	31	30	29		27			24	23	22	21	20	19		17			73					15	14	13	12	11	9	8	7	6	5	4	3	2	1		
72	71	69	68	67	66	64	63	62			59	58	57	56		54	53																																																																																								
52	51	50	49	48	47	46	44	43	42			39	38	37	36	35	34	33																																																																																							
			32	31	30	29		27			24	23	22	21	20	19		17																																																																																							
73					15	14	13	12	11	9	8	7	6	5	4	3	2	1																																																																																							

SEE NEXT PAGE FOR ADDITIONAL NUMBERS

ENTER DESCRIPTION ELEC NO: UAU2016-0232 DRAWN BY: 2015/08/14 CHKD: APPR: WJSHY REV: G34	QUALITY SYMBOLS ∇=0 ∇=0 ∇=0	GENERAL TOLERANCES (UNLESS SPECIFIED) mm INCH 4 PLACES ± --- ± --- 3 PLACES ± --- ± --- 2 PLACES ± --- ± --- 1 PLACE ± --- ± --- 0 PLACE ± --- ± ---	DIMENSION STYLE MM ONLY	SCALE DESIGN UNITS METRIC	THIRD ANGLE PROJECTION
	DRAFT WHERE APPLICABLE MUST REMAIN WITHIN DIMENSIONS		DRAWN BY: SKRAJENDRANA 2011/02/14 CHECKED BY: MYANSLAMBROU 2011/02/14 APPROVED BY:	TITLE MX123 66/73/80CKT HRNS CONN ASSY	
	SEE BOM TABLE		MATERIAL NO. DOCUMENT NO. SD-34566-001		SHEET NO. 12 OF 85
	THIS DRAWING CONTAINS INFORMATION THAT IS PROPRIETARY TO MOLEX INCORPORATED AND SHOULD NOT BE USED WITHOUT WRITTEN PERMISSION				

STATUS	GM PART #	MATERIAL #	PART/MATERIAL REVISION	WIRE DRESS OPTION	KEY OPTION	COLOR (TPA)	NUMBERS INDICATE CAVITIES OPEN FOR CIRCUITS																																																																											
AVAILABLE	NOT APPLICABLE	34566-9203	G	0	A	BLACK	<table border="1"> <tr><td>72</td><td>71</td><td>70</td><td>69</td><td>68</td><td>67</td><td>66</td><td>64</td><td>63</td><td>62</td><td>60</td><td>59</td><td></td><td></td><td>55</td><td>54</td><td>53</td></tr> <tr><td>52</td><td></td><td></td><td>49</td><td>48</td><td></td><td></td><td>44</td><td>43</td><td>42</td><td>40</td><td>39</td><td>38</td><td></td><td>35</td><td>34</td><td>33</td></tr> <tr><td></td><td></td><td>73</td><td></td><td></td><td>30</td><td>29</td><td>28</td><td>27</td><td></td><td>24</td><td>23</td><td></td><td></td><td>19</td><td>18</td><td>17</td></tr> <tr><td></td><td></td><td></td><td>16</td><td></td><td></td><td>13</td><td>12</td><td>11</td><td></td><td>9</td><td>8</td><td>7</td><td>6</td><td>5</td><td>4</td><td>3</td><td>2</td><td>1</td></tr> </table>	72	71	70	69	68	67	66	64	63	62	60	59			55	54	53	52			49	48			44	43	42	40	39	38		35	34	33			73			30	29	28	27		24	23			19	18	17				16			13	12	11		9	8	7	6	5	4	3	2	1					
72	71	70	69	68	67	66	64	63	62	60	59			55	54	53																																																																		
52			49	48			44	43	42	40	39	38		35	34	33																																																																		
		73			30	29	28	27		24	23			19	18	17																																																																		
			16			13	12	11		9	8	7	6	5	4	3	2	1																																																																
AVAILABLE	NOT APPLICABLE	34566-9303	G	0	A	BLACK	<table border="1"> <tr><td>72</td><td>71</td><td></td><td>69</td><td>68</td><td>67</td><td>66</td><td>64</td><td>63</td><td>62</td><td></td><td>59</td><td>58</td><td>57</td><td>56</td><td>55</td><td>54</td><td>53</td></tr> <tr><td>52</td><td>51</td><td>50</td><td>49</td><td>48</td><td>47</td><td>46</td><td>44</td><td>43</td><td>42</td><td></td><td>39</td><td>38</td><td>37</td><td>36</td><td>35</td><td>34</td><td>33</td></tr> <tr><td></td><td></td><td>73</td><td></td><td>32</td><td>31</td><td>30</td><td>29</td><td>27</td><td></td><td>24</td><td>23</td><td>22</td><td>21</td><td>20</td><td>19</td><td>18</td><td>17</td></tr> <tr><td></td><td></td><td></td><td>15</td><td>14</td><td>13</td><td>12</td><td>11</td><td></td><td></td><td>9</td><td>8</td><td>7</td><td>6</td><td>5</td><td>4</td><td>3</td><td>2</td><td>1</td></tr> </table>	72	71		69	68	67	66	64	63	62		59	58	57	56	55	54	53	52	51	50	49	48	47	46	44	43	42		39	38	37	36	35	34	33			73		32	31	30	29	27		24	23	22	21	20	19	18	17				15	14	13	12	11			9	8	7	6	5	4	3	2	1		
72	71		69	68	67	66	64	63	62		59	58	57	56	55	54	53																																																																	
52	51	50	49	48	47	46	44	43	42		39	38	37	36	35	34	33																																																																	
		73		32	31	30	29	27		24	23	22	21	20	19	18	17																																																																	
			15	14	13	12	11			9	8	7	6	5	4	3	2	1																																																																
AVAILABLE	NOT APPLICABLE	34566-9403	G	0	B	ST GRY	<table border="1"> <tr><td></td><td></td><td></td><td>68</td><td>67</td><td>66</td><td>65</td><td></td><td></td><td></td><td></td><td>59</td><td>58</td><td>57</td><td></td><td></td><td>54</td><td>53</td></tr> <tr><td></td><td>51</td><td>50</td><td>49</td><td>48</td><td>46</td><td>45</td><td>43</td><td>42</td><td>41</td><td></td><td>40</td><td>39</td><td>38</td><td>37</td><td>35</td><td>34</td><td>33</td></tr> <tr><td></td><td></td><td>73</td><td></td><td>32</td><td>31</td><td>30</td><td></td><td></td><td>26</td><td>24</td><td>23</td><td>22</td><td></td><td>20</td><td></td><td></td><td></td></tr> <tr><td></td><td></td><td></td><td>16</td><td></td><td></td><td>13</td><td></td><td></td><td>10</td><td>9</td><td>8</td><td>7</td><td>6</td><td>5</td><td>4</td><td></td><td></td></tr> </table>				68	67	66	65					59	58	57			54	53		51	50	49	48	46	45	43	42	41		40	39	38	37	35	34	33			73		32	31	30			26	24	23	22		20							16			13			10	9	8	7	6	5	4					
			68	67	66	65					59	58	57			54	53																																																																	
	51	50	49	48	46	45	43	42	41		40	39	38	37	35	34	33																																																																	
		73		32	31	30			26	24	23	22		20																																																																				
			16			13			10	9	8	7	6	5	4																																																																			
AVAILABLE	NOT APPLICABLE	34566-9503	G	0	A	BLACK	<table border="1"> <tr><td>72</td><td>71</td><td>70</td><td>69</td><td>68</td><td></td><td></td><td>65</td><td>64</td><td>63</td><td>61</td><td>59</td><td>58</td><td>57</td><td>56</td><td></td><td></td><td></td></tr> <tr><td>52</td><td>51</td><td></td><td>49</td><td></td><td>47</td><td></td><td></td><td></td><td></td><td>41</td><td></td><td></td><td>38</td><td>37</td><td>36</td><td>34</td><td>33</td></tr> <tr><td></td><td></td><td>73</td><td></td><td>32</td><td>31</td><td>30</td><td>29</td><td>28</td><td>27</td><td></td><td>24</td><td>23</td><td></td><td></td><td>20</td><td>19</td><td>18</td><td>17</td></tr> <tr><td></td><td></td><td></td><td>16</td><td></td><td></td><td>13</td><td>12</td><td>11</td><td>10</td><td>9</td><td></td><td></td><td></td><td></td><td></td><td></td><td></td><td>1</td></tr> </table>	72	71	70	69	68			65	64	63	61	59	58	57	56				52	51		49		47					41			38	37	36	34	33			73		32	31	30	29	28	27		24	23			20	19	18	17				16			13	12	11	10	9								1	
72	71	70	69	68			65	64	63	61	59	58	57	56																																																																				
52	51		49		47					41			38	37	36	34	33																																																																	
		73		32	31	30	29	28	27		24	23			20	19	18	17																																																																
			16			13	12	11	10	9								1																																																																
AVAILABLE	NOT APPLICABLE	34566-9603	G	0	A	BLACK	<table border="1"> <tr><td></td><td>71</td><td>70</td><td>69</td><td>68</td><td></td><td>66</td><td>65</td><td>64</td><td>63</td><td>61</td><td>59</td><td>58</td><td>57</td><td>56</td><td></td><td></td><td></td></tr> <tr><td>52</td><td></td><td>50</td><td>49</td><td></td><td>47</td><td></td><td></td><td></td><td></td><td>41</td><td></td><td></td><td>38</td><td>37</td><td>36</td><td>35</td><td>34</td><td>33</td></tr> <tr><td></td><td></td><td>73</td><td></td><td>32</td><td>31</td><td>30</td><td>29</td><td>28</td><td>27</td><td></td><td>24</td><td>23</td><td></td><td></td><td>20</td><td>19</td><td>18</td><td>17</td></tr> <tr><td></td><td></td><td></td><td>16</td><td>15</td><td>14</td><td>13</td><td>12</td><td>11</td><td>10</td><td>9</td><td></td><td></td><td></td><td></td><td></td><td></td><td></td><td>1</td></tr> </table>		71	70	69	68		66	65	64	63	61	59	58	57	56				52		50	49		47					41			38	37	36	35	34	33			73		32	31	30	29	28	27		24	23			20	19	18	17				16	15	14	13	12	11	10	9								1
	71	70	69	68		66	65	64	63	61	59	58	57	56																																																																				
52		50	49		47					41			38	37	36	35	34	33																																																																
		73		32	31	30	29	28	27		24	23			20	19	18	17																																																																
			16	15	14	13	12	11	10	9								1																																																																
AVAILABLE	NOT APPLICABLE	34566-9703	G	0	A	BLACK	<table border="1"> <tr><td>72</td><td>71</td><td>70</td><td>69</td><td>68</td><td></td><td></td><td>65</td><td>64</td><td>63</td><td>61</td><td>59</td><td></td><td>57</td><td>56</td><td></td><td></td><td></td></tr> <tr><td>52</td><td>51</td><td>50</td><td>49</td><td></td><td>47</td><td></td><td></td><td></td><td></td><td>41</td><td></td><td></td><td>38</td><td>37</td><td>36</td><td>34</td><td>33</td></tr> <tr><td></td><td></td><td>73</td><td></td><td>32</td><td>31</td><td>30</td><td>29</td><td>28</td><td>27</td><td></td><td>24</td><td>23</td><td></td><td></td><td>20</td><td>19</td><td>18</td><td>17</td></tr> <tr><td></td><td></td><td></td><td>16</td><td></td><td></td><td>13</td><td>12</td><td>11</td><td>10</td><td>9</td><td></td><td></td><td></td><td></td><td>3</td><td>2</td><td>1</td><td></td></tr> </table>	72	71	70	69	68			65	64	63	61	59		57	56				52	51	50	49		47					41			38	37	36	34	33			73		32	31	30	29	28	27		24	23			20	19	18	17				16			13	12	11	10	9					3	2	1		
72	71	70	69	68			65	64	63	61	59		57	56																																																																				
52	51	50	49		47					41			38	37	36	34	33																																																																	
		73		32	31	30	29	28	27		24	23			20	19	18	17																																																																
			16			13	12	11	10	9					3	2	1																																																																	
AVAILABLE	NOT APPLICABLE	34566-9803	G	0	A	BLACK	<table border="1"> <tr><td>72</td><td>71</td><td>70</td><td>69</td><td>68</td><td></td><td></td><td>65</td><td>64</td><td>63</td><td>61</td><td>59</td><td></td><td>57</td><td>56</td><td></td><td></td><td></td></tr> <tr><td>52</td><td>51</td><td>50</td><td>49</td><td></td><td>47</td><td></td><td></td><td></td><td></td><td>41</td><td></td><td></td><td>38</td><td>37</td><td>36</td><td>34</td><td>33</td></tr> <tr><td></td><td></td><td>73</td><td></td><td>32</td><td>31</td><td>30</td><td>29</td><td>28</td><td>27</td><td></td><td>24</td><td>23</td><td></td><td></td><td>20</td><td>19</td><td>18</td><td>17</td></tr> <tr><td></td><td></td><td></td><td>16</td><td></td><td></td><td>13</td><td>12</td><td>11</td><td>10</td><td>9</td><td></td><td></td><td></td><td></td><td></td><td></td><td></td><td>1</td></tr> </table>	72	71	70	69	68			65	64	63	61	59		57	56				52	51	50	49		47					41			38	37	36	34	33			73		32	31	30	29	28	27		24	23			20	19	18	17				16			13	12	11	10	9								1	
72	71	70	69	68			65	64	63	61	59		57	56																																																																				
52	51	50	49		47					41			38	37	36	34	33																																																																	
		73		32	31	30	29	28	27		24	23			20	19	18	17																																																																
			16			13	12	11	10	9								1																																																																
AVAILABLE	NOT APPLICABLE	34566-9903	G	0	A	BLACK	<table border="1"> <tr><td></td><td>71</td><td></td><td>69</td><td>68</td><td></td><td></td><td>65</td><td>64</td><td>63</td><td>61</td><td>59</td><td>58</td><td>57</td><td>56</td><td></td><td></td><td></td></tr> <tr><td>52</td><td></td><td>50</td><td>49</td><td></td><td>47</td><td></td><td></td><td></td><td></td><td>41</td><td></td><td></td><td>38</td><td>37</td><td>36</td><td>34</td><td>33</td></tr> <tr><td></td><td></td><td>73</td><td></td><td>32</td><td>31</td><td>30</td><td>29</td><td>28</td><td>27</td><td></td><td>24</td><td>23</td><td></td><td></td><td>20</td><td>19</td><td>18</td><td>17</td></tr> <tr><td></td><td></td><td></td><td>16</td><td></td><td></td><td>13</td><td>12</td><td>11</td><td>10</td><td>9</td><td></td><td></td><td></td><td></td><td></td><td></td><td></td><td>1</td></tr> </table>		71		69	68			65	64	63	61	59	58	57	56				52		50	49		47					41			38	37	36	34	33			73		32	31	30	29	28	27		24	23			20	19	18	17				16			13	12	11	10	9								1	
	71		69	68			65	64	63	61	59	58	57	56																																																																				
52		50	49		47					41			38	37	36	34	33																																																																	
		73		32	31	30	29	28	27		24	23			20	19	18	17																																																																
			16			13	12	11	10	9								1																																																																

SEE NEXT PAGE FOR ADDITIONAL NUMBERS

ENTER DESCRIPTION EEC NO: UAU2016-0232 DRAWN BY: 2015/08/14 CHKD: APPR: IKOSHY 2015/08/14 REV: G34	QUALITY SYMBOLS	GENERAL TOLERANCES (UNLESS SPECIFIED)	DIMENSION STYLE	SCALE	DESIGN UNITS	THIRD ANGLE PROJECTION	
	∇=0 ∇=0 ∇=0	mm INCH 4 PLACES ±--- ±--- 3 PLACES ±--- ±--- 2 PLACES ±--- ±--- 1 PLACE ±--- ±--- 0 PLACE ±--- ±---	MM ONLY	DRAWN BY: SKRA JENDRANA 2011/02/14 CHECKED BY: MVANSLAMBROU 2011/02/14 APPROVED BY:	METRIC		
	ANGULAR ±---° DRAFT WHERE APPLICABLE MUST REMAIN WITHIN DIMENSIONS	SEE BOM TABLE	MATERIAL NO. DOCUMENT NO.	TITLE MX123 66/73/80CKT HRNS CONN ASSY molex			
							SHEET NO. 14 OF 85

STATUS	GM PART #	MATERIAL #	PART/MATERIAL REVISION	WIRE DRESS OPTION	KEY OPTION	COLOR (TPA)	NUMBERS INDICATE CAVITIES OPEN FOR CIRCUITS																																																																										
AVAILABLE	NOT APPLICABLE	34566-1013	G	0	A	BLACK	<table border="1"> <tr><td>71</td><td>69</td><td>68</td><td></td><td>65</td><td>64</td><td>63</td><td>61</td><td>59</td><td>58</td><td>57</td><td>56</td><td></td><td></td><td></td></tr> <tr><td>52</td><td>50</td><td>49</td><td>47</td><td></td><td></td><td></td><td>41</td><td></td><td>38</td><td>37</td><td>36</td><td></td><td>34</td><td>33</td></tr> <tr><td></td><td></td><td>73</td><td>32</td><td>31</td><td>30</td><td>29</td><td>28</td><td>27</td><td></td><td>24</td><td>23</td><td></td><td>20</td><td>19</td><td>18</td><td>17</td></tr> <tr><td></td><td></td><td></td><td>16</td><td></td><td></td><td>13</td><td>12</td><td>11</td><td>10</td><td>9</td><td></td><td></td><td></td><td>3</td><td>2</td><td>1</td></tr> </table>	71	69	68		65	64	63	61	59	58	57	56				52	50	49	47				41		38	37	36		34	33			73	32	31	30	29	28	27		24	23		20	19	18	17				16			13	12	11	10	9				3	2	1										
71	69	68		65	64	63	61	59	58	57	56																																																																						
52	50	49	47				41		38	37	36		34	33																																																																			
		73	32	31	30	29	28	27		24	23		20	19	18	17																																																																	
			16			13	12	11	10	9				3	2	1																																																																	
AVAILABLE	NOT APPLICABLE	34566-1023	G	0	A	BLACK	<table border="1"> <tr><td></td><td>70</td><td></td><td>67</td><td>66</td><td>65</td><td></td><td></td><td></td><td>58</td><td>57</td><td>55</td><td>54</td><td></td><td></td></tr> <tr><td></td><td>50</td><td>49</td><td>47</td><td></td><td></td><td>44</td><td>43</td><td>42</td><td>41</td><td>39</td><td>37</td><td>35</td><td></td><td></td></tr> <tr><td></td><td></td><td>73</td><td>32</td><td>30</td><td></td><td>27</td><td>25</td><td>24</td><td></td><td>21</td><td>20</td><td>19</td><td>18</td><td>17</td></tr> <tr><td></td><td></td><td></td><td>16</td><td>15</td><td>13</td><td></td><td>10</td><td>9</td><td>8</td><td>6</td><td>5</td><td></td><td>3</td><td>2</td><td>1</td></tr> </table>		70		67	66	65				58	57	55	54				50	49	47			44	43	42	41	39	37	35					73	32	30		27	25	24		21	20	19	18	17				16	15	13		10	9	8	6	5		3	2	1													
	70		67	66	65				58	57	55	54																																																																					
	50	49	47			44	43	42	41	39	37	35																																																																					
		73	32	30		27	25	24		21	20	19	18	17																																																																			
			16	15	13		10	9	8	6	5		3	2	1																																																																		
AVAILABLE	NOT APPLICABLE	34566-1033	G	0	A	BLACK	<table border="1"> <tr><td>72</td><td>70</td><td></td><td>67</td><td>66</td><td>65</td><td></td><td></td><td></td><td>58</td><td>57</td><td>55</td><td>54</td><td></td><td></td></tr> <tr><td></td><td>50</td><td>49</td><td>47</td><td></td><td></td><td>44</td><td>43</td><td>42</td><td>41</td><td>39</td><td>37</td><td>35</td><td></td><td></td></tr> <tr><td></td><td></td><td>73</td><td>32</td><td>30</td><td></td><td>27</td><td>26</td><td>25</td><td>24</td><td></td><td>21</td><td>20</td><td>19</td><td>18</td><td>17</td></tr> <tr><td></td><td></td><td></td><td>16</td><td>15</td><td>13</td><td></td><td>10</td><td>9</td><td>8</td><td>6</td><td>5</td><td></td><td>3</td><td>2</td><td>1</td></tr> </table>	72	70		67	66	65				58	57	55	54				50	49	47			44	43	42	41	39	37	35					73	32	30		27	26	25	24		21	20	19	18	17				16	15	13		10	9	8	6	5		3	2	1												
72	70		67	66	65				58	57	55	54																																																																					
	50	49	47			44	43	42	41	39	37	35																																																																					
		73	32	30		27	26	25	24		21	20	19	18	17																																																																		
			16	15	13		10	9	8	6	5		3	2	1																																																																		
AVAILABLE	NOT APPLICABLE	34566-1043	G	0	B	ST GRAY	<table border="1"> <tr><td>71</td><td>70</td><td>68</td><td></td><td>66</td><td>65</td><td></td><td></td><td></td><td>59</td><td>58</td><td>57</td><td></td><td>54</td><td>53</td></tr> <tr><td>51</td><td>50</td><td>49</td><td>48</td><td>46</td><td>45</td><td></td><td>43</td><td>41</td><td>40</td><td>39</td><td>38</td><td>37</td><td>36</td><td>35</td><td>33</td></tr> <tr><td></td><td></td><td>73</td><td>32</td><td>31</td><td>30</td><td></td><td></td><td></td><td>24</td><td>23</td><td>22</td><td></td><td>20</td><td></td></tr> <tr><td></td><td></td><td></td><td>16</td><td></td><td></td><td>13</td><td>12</td><td>11</td><td>10</td><td>9</td><td>8</td><td>7</td><td>6</td><td>5</td><td>4</td></tr> </table>	71	70	68		66	65				59	58	57		54	53	51	50	49	48	46	45		43	41	40	39	38	37	36	35	33			73	32	31	30				24	23	22		20					16			13	12	11	10	9	8	7	6	5	4												
71	70	68		66	65				59	58	57		54	53																																																																			
51	50	49	48	46	45		43	41	40	39	38	37	36	35	33																																																																		
		73	32	31	30				24	23	22		20																																																																				
			16			13	12	11	10	9	8	7	6	5	4																																																																		
AVAILABLE	NOT APPLICABLE	34566-1053	G	0	H	ST GRAY	<table border="1"> <tr><td>79</td><td>78</td><td>77</td><td>76</td><td>75</td><td>74</td><td>73</td><td>72</td><td>71</td><td>70</td><td>69</td><td>68</td><td></td><td>66</td><td>65</td><td>64</td><td>63</td><td>61</td></tr> <tr><td>60</td><td>59</td><td>58</td><td>57</td><td>56</td><td></td><td>53</td><td>52</td><td></td><td>50</td><td></td><td></td><td></td><td></td><td></td><td>44</td><td>43</td><td>41</td></tr> <tr><td>40</td><td>39</td><td>38</td><td>37</td><td></td><td>35</td><td>34</td><td>33</td><td>32</td><td></td><td>30</td><td>29</td><td></td><td>27</td><td>26</td><td></td><td></td><td>22</td><td>21</td></tr> <tr><td>20</td><td>19</td><td>18</td><td>17</td><td>16</td><td></td><td>14</td><td>13</td><td>12</td><td>11</td><td></td><td>9</td><td>8</td><td></td><td>6</td><td>5</td><td></td><td>3</td><td>2</td></tr> </table>	79	78	77	76	75	74	73	72	71	70	69	68		66	65	64	63	61	60	59	58	57	56		53	52		50						44	43	41	40	39	38	37		35	34	33	32		30	29		27	26			22	21	20	19	18	17	16		14	13	12	11		9	8		6	5		3	2
79	78	77	76	75	74	73	72	71	70	69	68		66	65	64	63	61																																																																
60	59	58	57	56		53	52		50						44	43	41																																																																
40	39	38	37		35	34	33	32		30	29		27	26			22	21																																																															
20	19	18	17	16		14	13	12	11		9	8		6	5		3	2																																																															
AVAILABLE	NOT APPLICABLE	34566-1063	G	0	B	ST GRAY	<table border="1"> <tr><td></td><td></td><td></td><td></td><td></td><td>65</td><td></td><td></td><td></td><td>60</td><td>59</td><td></td><td>57</td><td>56</td><td>55</td><td></td><td>53</td></tr> <tr><td></td><td></td><td>49</td><td>48</td><td>47</td><td></td><td>44</td><td></td><td></td><td>40</td><td>39</td><td></td><td>37</td><td>36</td><td>35</td><td></td><td>33</td></tr> <tr><td></td><td></td><td></td><td></td><td></td><td></td><td>29</td><td>28</td><td></td><td>24</td><td>23</td><td></td><td>21</td><td></td><td></td><td></td><td></td><td></td><td>2</td></tr> <tr><td></td><td></td><td></td><td></td><td></td><td></td><td></td><td></td><td></td><td></td><td></td><td></td><td></td><td></td><td></td><td></td><td></td><td></td><td></td></tr> </table>						65				60	59		57	56	55		53			49	48	47		44			40	39		37	36	35		33							29	28		24	23		21						2																					
					65				60	59		57	56	55		53																																																																	
		49	48	47		44			40	39		37	36	35		33																																																																	
						29	28		24	23		21						2																																																															
AVAILABLE	NOT APPLICABLE	34566-1073	G	0	A	BLACK	<table border="1"> <tr><td>72</td><td>71</td><td>70</td><td>69</td><td>68</td><td>67</td><td>66</td><td>65</td><td>64</td><td>63</td><td>61</td><td>59</td><td>58</td><td>57</td><td>56</td><td></td><td>54</td></tr> <tr><td></td><td>50</td><td>49</td><td>48</td><td>47</td><td></td><td></td><td></td><td></td><td>42</td><td>41</td><td></td><td>38</td><td>37</td><td>36</td><td></td><td>34</td><td>33</td></tr> <tr><td></td><td></td><td>73</td><td>32</td><td>31</td><td>30</td><td>29</td><td>28</td><td>27</td><td>26</td><td></td><td>24</td><td>23</td><td></td><td></td><td>20</td><td>19</td><td>18</td></tr> <tr><td></td><td></td><td></td><td>16</td><td></td><td></td><td>13</td><td>12</td><td>11</td><td>10</td><td>9</td><td></td><td></td><td></td><td></td><td></td><td></td><td></td></tr> </table>	72	71	70	69	68	67	66	65	64	63	61	59	58	57	56		54		50	49	48	47					42	41		38	37	36		34	33			73	32	31	30	29	28	27	26		24	23			20	19	18				16			13	12	11	10	9										
72	71	70	69	68	67	66	65	64	63	61	59	58	57	56		54																																																																	
	50	49	48	47					42	41		38	37	36		34	33																																																																
		73	32	31	30	29	28	27	26		24	23			20	19	18																																																																
			16			13	12	11	10	9																																																																							
AVAILABLE	NOT APPLICABLE	34566-1083	G	0	B	ST GRAY	<table border="1"> <tr><td></td><td></td><td></td><td>68</td><td>67</td><td>66</td><td>65</td><td>64</td><td></td><td></td><td></td><td>59</td><td>58</td><td>57</td><td></td><td>55</td><td>54</td><td>53</td></tr> <tr><td></td><td>51</td><td>50</td><td>49</td><td>48</td><td>46</td><td>45</td><td></td><td>43</td><td>42</td><td>41</td><td>40</td><td>39</td><td>38</td><td>37</td><td></td><td>35</td><td>33</td></tr> <tr><td></td><td></td><td></td><td>73</td><td>32</td><td>31</td><td>30</td><td></td><td></td><td>26</td><td>24</td><td>23</td><td>22</td><td></td><td>20</td><td></td><td></td><td></td></tr> <tr><td></td><td></td><td></td><td></td><td>16</td><td></td><td></td><td>13</td><td></td><td>10</td><td>9</td><td>8</td><td>7</td><td>6</td><td>5</td><td>4</td><td>3</td><td>2</td></tr> </table>				68	67	66	65	64				59	58	57		55	54	53		51	50	49	48	46	45		43	42	41	40	39	38	37		35	33				73	32	31	30			26	24	23	22		20								16			13		10	9	8	7	6	5	4	3	2		
			68	67	66	65	64				59	58	57		55	54	53																																																																
	51	50	49	48	46	45		43	42	41	40	39	38	37		35	33																																																																
			73	32	31	30			26	24	23	22		20																																																																			
				16			13		10	9	8	7	6	5	4	3	2																																																																

SEE NEXT PAGE FOR ADDITIONAL NUMBERS

ENTER DESCRIPTION EC NO: UAU2016-0232 DRAWN BY: SKRAJENDRANA CHECKED BY: MVANSLAMBROU APPR: WOSHY G34	QUALITY SYMBOLS ▽=0 ▽=0 ▽=0 ▽=0	GENERAL TOLERANCES (UNLESS SPECIFIED) mm INCH 4 PLACES ± --- ± --- 3 PLACES ± --- ± --- 2 PLACES ± --- ± --- 1 PLACE ± --- ± --- 0 PLACE ± --- ± ---	DIMENSION STYLE MM ONLY	SCALE DESIGN UNITS METRIC	THIRD ANGLE PROJECTION
	MATERIAL NO. DOCUMENT NO.	DRAWN BY DATE SKRAJENDRANA 2011/02/14	CHECKED BY DATE MVANSLAMBROU 2011/02/14	TITLE MX123 66/73/80CKT HRNS CONN ASSY	SHEET NO. 15 OF 85
	ANGULAR ± ---° DRAFT WHERE APPLICABLE MUST REMAIN WITHIN DIMENSIONS	APPROVED BY DATE	SEE BOM TABLE	SD-34566-001	MOLEX
	THIS DRAWING CONTAINS INFORMATION THAT IS PROPRIETARY TO MOLEX INCORPORATED AND SHOULD NOT BE USED WITHOUT WRITTEN PERMISSION				

STATUS	GM PART #	MATERIAL #	PART/MATERIAL REVISION	WIRE DRESS OPTION	KEY OPTION	COLOR (TPA)	NUMBERS INDICATE CAVITIES OPEN FOR CIRCUITS																																																																								
AVAILABLE	NOT APPLICABLE	34566-1093	G	0	A	BLACK	<table border="1"> <tr><td></td><td>70</td><td>68</td><td>67</td><td>66</td><td></td><td></td><td></td><td></td><td></td><td></td><td></td><td></td><td>58</td><td>56</td><td>55</td><td>54</td></tr> <tr><td></td><td></td><td>49</td><td>47</td><td></td><td>44</td><td>43</td><td>42</td><td>41</td><td>39</td><td>37</td><td>36</td><td>34</td><td></td><td></td><td></td><td></td></tr> <tr><td>73</td><td></td><td></td><td>31</td><td>30</td><td></td><td>27</td><td>25</td><td>24</td><td></td><td>21</td><td>20</td><td>19</td><td>18</td><td></td><td></td><td></td></tr> <tr><td></td><td></td><td></td><td></td><td></td><td>13</td><td></td><td></td><td></td><td>6</td><td>5</td><td>4</td><td>3</td><td>1</td><td></td><td></td><td></td></tr> </table>		70	68	67	66									58	56	55	54			49	47		44	43	42	41	39	37	36	34					73			31	30		27	25	24		21	20	19	18									13				6	5	4	3	1							
	70	68	67	66									58	56	55	54																																																															
		49	47		44	43	42	41	39	37	36	34																																																																			
73			31	30		27	25	24		21	20	19	18																																																																		
					13				6	5	4	3	1																																																																		
AVAILABLE	NOT APPLICABLE	34566-1123	G	0	H	ST GRAY	<table border="1"> <tr><td></td><td>78</td><td></td><td></td><td></td><td></td><td>72</td><td>71</td><td>70</td><td>69</td><td>68</td><td>67</td><td>66</td><td>65</td><td>64</td><td>63</td><td>61</td></tr> <tr><td></td><td>58</td><td>57</td><td>56</td><td></td><td></td><td>53</td><td>52</td><td>51</td><td>50</td><td></td><td></td><td></td><td></td><td>44</td><td>43</td><td>41</td></tr> <tr><td>40</td><td></td><td>37</td><td>35</td><td>34</td><td>33</td><td>32</td><td>30</td><td>29</td><td>27</td><td>26</td><td></td><td></td><td></td><td></td><td></td><td>22</td><td>21</td></tr> <tr><td>20</td><td>19</td><td>18</td><td>17</td><td>16</td><td>14</td><td>12</td><td>10</td><td>9</td><td>8</td><td>7</td><td>6</td><td>5</td><td>3</td><td>2</td><td>1</td><td></td><td></td></tr> </table>		78					72	71	70	69	68	67	66	65	64	63	61		58	57	56			53	52	51	50					44	43	41	40		37	35	34	33	32	30	29	27	26						22	21	20	19	18	17	16	14	12	10	9	8	7	6	5	3	2	1				
	78					72	71	70	69	68	67	66	65	64	63	61																																																															
	58	57	56			53	52	51	50					44	43	41																																																															
40		37	35	34	33	32	30	29	27	26						22	21																																																														
20	19	18	17	16	14	12	10	9	8	7	6	5	3	2	1																																																																
AVAILABLE	NOT APPLICABLE	34566-1133	G	0	A	BLACK	<table border="1"> <tr><td></td><td>70</td><td>68</td><td>67</td><td>66</td><td></td><td></td><td></td><td></td><td></td><td>61</td><td></td><td></td><td>58</td><td>57</td><td>55</td><td>54</td></tr> <tr><td></td><td></td><td>49</td><td>47</td><td></td><td>45</td><td>44</td><td>43</td><td>42</td><td>41</td><td>39</td><td>37</td><td>34</td><td></td><td></td><td></td><td></td></tr> <tr><td>73</td><td></td><td></td><td>32</td><td>30</td><td></td><td>27</td><td>25</td><td>24</td><td></td><td></td><td></td><td>21</td><td>20</td><td>19</td><td>18</td><td></td></tr> <tr><td></td><td></td><td></td><td></td><td></td><td>13</td><td></td><td>11</td><td></td><td></td><td></td><td></td><td>6</td><td>5</td><td>3</td><td>1</td><td></td></tr> </table>		70	68	67	66						61			58	57	55	54			49	47		45	44	43	42	41	39	37	34					73			32	30		27	25	24				21	20	19	18							13		11					6	5	3	1					
	70	68	67	66						61			58	57	55	54																																																															
		49	47		45	44	43	42	41	39	37	34																																																																			
73			32	30		27	25	24				21	20	19	18																																																																
					13		11					6	5	3	1																																																																
AVAILABLE	NOT APPLICABLE	34566-1143	G	0	A	BLACK	<table border="1"> <tr><td></td><td></td><td>68</td><td></td><td>65</td><td>63</td><td>61</td><td>59</td><td>58</td><td>56</td><td></td><td></td><td></td><td></td><td></td><td></td><td></td><td>53</td></tr> <tr><td>52</td><td>50</td><td></td><td>47</td><td></td><td></td><td>41</td><td></td><td>38</td><td>37</td><td>36</td><td>35</td><td>34</td><td>33</td><td></td><td></td><td></td><td></td></tr> <tr><td>73</td><td></td><td>32</td><td>31</td><td>30</td><td>29</td><td>28</td><td>27</td><td>25</td><td>24</td><td>23</td><td>22</td><td>21</td><td>20</td><td>19</td><td>18</td><td>17</td><td></td></tr> <tr><td></td><td></td><td>16</td><td>15</td><td>14</td><td>13</td><td>12</td><td>11</td><td>10</td><td>9</td><td></td><td></td><td></td><td></td><td></td><td></td><td></td><td>1</td></tr> </table>			68		65	63	61	59	58	56								53	52	50		47			41		38	37	36	35	34	33					73		32	31	30	29	28	27	25	24	23	22	21	20	19	18	17				16	15	14	13	12	11	10	9								1
		68		65	63	61	59	58	56								53																																																														
52	50		47			41		38	37	36	35	34	33																																																																		
73		32	31	30	29	28	27	25	24	23	22	21	20	19	18	17																																																															
		16	15	14	13	12	11	10	9								1																																																														
AVAILABLE	NOT APPLICABLE	34566-1153	G	0	A	BLACK	<table border="1"> <tr><td></td><td>70</td><td></td><td>67</td><td>66</td><td>65</td><td></td><td></td><td></td><td></td><td></td><td></td><td></td><td>58</td><td>57</td><td>55</td><td></td><td></td></tr> <tr><td></td><td></td><td>49</td><td>47</td><td></td><td>44</td><td>43</td><td>42</td><td>41</td><td>39</td><td>37</td><td></td><td></td><td></td><td></td><td></td><td></td><td></td></tr> <tr><td>73</td><td></td><td></td><td>32</td><td>30</td><td></td><td>27</td><td>25</td><td>24</td><td>23</td><td>21</td><td>20</td><td>19</td><td>18</td><td></td><td></td><td></td><td></td></tr> <tr><td></td><td></td><td></td><td></td><td></td><td>13</td><td></td><td></td><td></td><td>8</td><td>6</td><td>5</td><td>3</td><td>1</td><td></td><td></td><td></td><td></td></tr> </table>		70		67	66	65								58	57	55					49	47		44	43	42	41	39	37								73			32	30		27	25	24	23	21	20	19	18										13				8	6	5	3	1				
	70		67	66	65								58	57	55																																																																
		49	47		44	43	42	41	39	37																																																																					
73			32	30		27	25	24	23	21	20	19	18																																																																		
					13				8	6	5	3	1																																																																		
AVAILABLE	NOT APPLICABLE	34566-1163	G	0	H	ST GRAY	<table border="1"> <tr><td></td><td>78</td><td></td><td></td><td></td><td></td><td>72</td><td>71</td><td>70</td><td>69</td><td>68</td><td>66</td><td>65</td><td>64</td><td>63</td><td>61</td><td></td><td></td></tr> <tr><td>60</td><td>59</td><td>58</td><td>57</td><td>56</td><td></td><td>53</td><td>52</td><td>50</td><td></td><td></td><td></td><td></td><td></td><td>44</td><td>43</td><td>41</td><td></td></tr> <tr><td>40</td><td></td><td>37</td><td>35</td><td>34</td><td></td><td>32</td><td>30</td><td>29</td><td>27</td><td>26</td><td></td><td></td><td></td><td></td><td></td><td>22</td><td>21</td></tr> <tr><td>20</td><td>19</td><td>18</td><td>17</td><td>16</td><td></td><td>13</td><td>12</td><td></td><td></td><td>8</td><td>6</td><td>5</td><td>3</td><td>2</td><td>1</td><td></td><td></td></tr> </table>		78					72	71	70	69	68	66	65	64	63	61			60	59	58	57	56		53	52	50						44	43	41		40		37	35	34		32	30	29	27	26						22	21	20	19	18	17	16		13	12			8	6	5	3	2	1		
	78					72	71	70	69	68	66	65	64	63	61																																																																
60	59	58	57	56		53	52	50						44	43	41																																																															
40		37	35	34		32	30	29	27	26						22	21																																																														
20	19	18	17	16		13	12			8	6	5	3	2	1																																																																
AVAILABLE	NOT APPLICABLE	34566-1173	G	0	A	BLACK	<table border="1"> <tr><td>72</td><td>71</td><td>69</td><td>68</td><td></td><td>65</td><td>64</td><td>63</td><td>62</td><td>61</td><td>60</td><td>59</td><td>58</td><td>56</td><td>54</td><td></td><td></td><td></td></tr> <tr><td>52</td><td>50</td><td>49</td><td>48</td><td>47</td><td>45</td><td></td><td>42</td><td>41</td><td></td><td></td><td></td><td>38</td><td>37</td><td>36</td><td>34</td><td>33</td><td></td></tr> <tr><td>73</td><td></td><td>32</td><td>31</td><td>30</td><td>29</td><td>28</td><td>27</td><td>26</td><td>24</td><td>23</td><td></td><td></td><td>20</td><td>19</td><td>18</td><td>17</td><td></td></tr> <tr><td></td><td></td><td>16</td><td></td><td>13</td><td>12</td><td>11</td><td>10</td><td>9</td><td></td><td></td><td></td><td></td><td></td><td></td><td></td><td></td><td></td></tr> </table>	72	71	69	68		65	64	63	62	61	60	59	58	56	54				52	50	49	48	47	45		42	41				38	37	36	34	33		73		32	31	30	29	28	27	26	24	23			20	19	18	17				16		13	12	11	10	9									
72	71	69	68		65	64	63	62	61	60	59	58	56	54																																																																	
52	50	49	48	47	45		42	41				38	37	36	34	33																																																															
73		32	31	30	29	28	27	26	24	23			20	19	18	17																																																															
		16		13	12	11	10	9																																																																							
AVAILABLE	NOT APPLICABLE	34566-1183	G	0	B	ST GRAY	<table border="1"> <tr><td></td><td></td><td></td><td></td><td>66</td><td>65</td><td>64</td><td>62</td><td></td><td></td><td>59</td><td>57</td><td>55</td><td>53</td><td></td><td></td><td></td><td></td></tr> <tr><td></td><td></td><td>49</td><td>48</td><td>47</td><td></td><td>44</td><td>42</td><td></td><td></td><td>39</td><td>37</td><td>35</td><td>33</td><td></td><td></td><td></td><td></td></tr> <tr><td>73</td><td></td><td></td><td></td><td></td><td>29</td><td>28</td><td></td><td></td><td></td><td>23</td><td>21</td><td></td><td>17</td><td></td><td></td><td></td><td></td></tr> <tr><td></td><td></td><td></td><td></td><td></td><td>12</td><td></td><td>9</td><td>7</td><td></td><td></td><td></td><td></td><td></td><td></td><td></td><td></td><td></td></tr> </table>					66	65	64	62			59	57	55	53							49	48	47		44	42			39	37	35	33					73					29	28				23	21		17										12		9	7									
				66	65	64	62			59	57	55	53																																																																		
		49	48	47		44	42			39	37	35	33																																																																		
73					29	28				23	21		17																																																																		
					12		9	7																																																																							

ENTER DESCRIPTION EC NO: UAU2016-0232 DRAWN BY: CHYK APPR: IKOSHY 2015/08/14 2015/08/14 G34	QUALITY SYMBOLS ∇=0 ∇=0 ∇=0	GENERAL TOLERANCES (UNLESS SPECIFIED) DIMENSION STYLE MM ONLY	SCALE METRIC	DESIGN UNITS METRIC	THIRD ANGLE PROJECTION	
	4 PLACES ±---+--- 3 PLACES ±---+--- 2 PLACES ±---+--- 1 PLACE ±---+--- 0 PLACE ±---+---	DIMENSION STYLE DRAWN BY: SKRAJENDRANA 2011/02/14 CHECKED BY: MYANSLAMBROU 2011/02/14 APPROVED BY:	DATE:	TITLE:	MX123 66/73/80CKT HRNS CONN ASSY	SHEET NO. 16 OF 85
	ANGULAR ±---° DRAFT WHERE APPLICABLE MUST REMAIN WITHIN DIMENSIONS	MATERIAL NO. SEE BOM TABLE	DOCUMENT NO. SD-34566-001	THIS DRAWING CONTAINS INFORMATION THAT IS PROPRIETARY TO MOLEX INCORPORATED AND SHOULD NOT BE USED WITHOUT WRITTEN PERMISSION		

STATUS	GM PART #	MATERIAL #	PART/MATERIAL REVISION	WIRE DRESS OPTION	KEY OPTION	COLOR (TPA)	NUMBERS INDICATE CAVITIES OPEN FOR CIRCUITS																																																																		
AVAILABLE	NOT APPLICABLE	34566-1193	G	0	A	BLACK	<table border="1"> <tr><td>72</td><td>71</td><td>69</td><td>68</td><td>67</td><td>66</td><td>64</td><td>63</td><td>62</td><td>60</td><td>59</td><td></td><td></td><td></td><td>54</td><td>53</td></tr> <tr><td>52</td><td></td><td>49</td><td>48</td><td>46</td><td>44</td><td>43</td><td>42</td><td></td><td>39</td><td></td><td></td><td></td><td></td><td>34</td><td>33</td></tr> <tr><td></td><td>73</td><td></td><td>32</td><td></td><td>29</td><td>27</td><td></td><td></td><td>23</td><td></td><td></td><td></td><td></td><td>17</td><td></td></tr> <tr><td></td><td></td><td></td><td></td><td>14</td><td>13</td><td>12</td><td>11</td><td>9</td><td>8</td><td>7</td><td>6</td><td>5</td><td>4</td><td>3</td><td>2</td><td>1</td></tr> </table>	72	71	69	68	67	66	64	63	62	60	59				54	53	52		49	48	46	44	43	42		39					34	33		73		32		29	27			23					17						14	13	12	11	9	8	7	6	5	4	3	2	1	
72	71	69	68	67	66	64	63	62	60	59				54	53																																																										
52		49	48	46	44	43	42		39					34	33																																																										
	73		32		29	27			23					17																																																											
				14	13	12	11	9	8	7	6	5	4	3	2	1																																																									
AVAILABLE	NOT APPLICABLE	34566-1213	G	0	A	BLACK	<table border="1"> <tr><td>72</td><td>71</td><td>69</td><td>68</td><td>67</td><td>66</td><td>64</td><td>63</td><td>62</td><td></td><td>59</td><td></td><td></td><td></td><td>54</td><td>53</td></tr> <tr><td>52</td><td></td><td></td><td>48</td><td></td><td>46</td><td>44</td><td>43</td><td>42</td><td></td><td>39</td><td></td><td></td><td></td><td></td><td>33</td></tr> <tr><td></td><td>73</td><td></td><td>32</td><td></td><td>29</td><td>27</td><td></td><td></td><td>24</td><td>23</td><td></td><td></td><td></td><td></td><td>17</td></tr> <tr><td></td><td></td><td></td><td></td><td>14</td><td>13</td><td>12</td><td>11</td><td>9</td><td>8</td><td></td><td></td><td>5</td><td>4</td><td>3</td><td>2</td><td>1</td></tr> </table>	72	71	69	68	67	66	64	63	62		59				54	53	52			48		46	44	43	42		39					33		73		32		29	27			24	23					17					14	13	12	11	9	8			5	4	3	2	1	
72	71	69	68	67	66	64	63	62		59				54	53																																																										
52			48		46	44	43	42		39					33																																																										
	73		32		29	27			24	23					17																																																										
				14	13	12	11	9	8			5	4	3	2	1																																																									
AVAILABLE	NOT APPLICABLE	34566-1223	G	0	B	ST GRY	<table border="1"> <tr><td></td><td></td><td></td><td>67</td><td>66</td><td>65</td><td>63</td><td>62</td><td></td><td>59</td><td>57</td><td>55</td><td>53</td><td></td><td></td><td></td></tr> <tr><td></td><td></td><td></td><td>48</td><td></td><td></td><td>43</td><td>42</td><td></td><td>39</td><td>37</td><td>35</td><td>33</td><td></td><td></td><td></td></tr> <tr><td></td><td>73</td><td></td><td></td><td></td><td>29</td><td>27</td><td>26</td><td></td><td>23</td><td>21</td><td></td><td></td><td></td><td></td><td>17</td></tr> <tr><td></td><td></td><td></td><td></td><td></td><td>12</td><td></td><td></td><td>9</td><td>7</td><td></td><td></td><td></td><td></td><td></td><td></td><td></td></tr> </table>				67	66	65	63	62		59	57	55	53							48			43	42		39	37	35	33					73				29	27	26		23	21					17						12			9	7								
			67	66	65	63	62		59	57	55	53																																																													
			48			43	42		39	37	35	33																																																													
	73				29	27	26		23	21					17																																																										
					12			9	7																																																																
AVAILABLE	NOT APPLICABLE	34566-1233	G	0	B	ST GRY	<table border="1"> <tr><td></td><td></td><td></td><td></td><td></td><td>65</td><td></td><td>62</td><td></td><td>59</td><td>57</td><td>55</td><td>53</td><td></td><td></td><td></td></tr> <tr><td></td><td></td><td></td><td>48</td><td>46</td><td></td><td></td><td>42</td><td></td><td>39</td><td>37</td><td>35</td><td>33</td><td></td><td></td><td></td></tr> <tr><td></td><td>73</td><td></td><td></td><td></td><td>29</td><td></td><td>26</td><td></td><td>23</td><td>21</td><td></td><td></td><td></td><td></td><td>17</td></tr> <tr><td></td><td></td><td></td><td></td><td></td><td>12</td><td></td><td></td><td>9</td><td>7</td><td></td><td></td><td></td><td></td><td></td><td></td><td></td></tr> </table>						65		62		59	57	55	53							48	46			42		39	37	35	33					73				29		26		23	21					17						12			9	7								
					65		62		59	57	55	53																																																													
			48	46			42		39	37	35	33																																																													
	73				29		26		23	21					17																																																										
					12			9	7																																																																
AVAILABLE	NOT APPLICABLE	34566-1243	G	0	B	ST GRY	<table border="1"> <tr><td></td><td></td><td></td><td></td><td></td><td></td><td></td><td></td><td></td><td>59</td><td>57</td><td>55</td><td>53</td><td></td><td></td><td></td></tr> <tr><td></td><td>50</td><td>48</td><td>46</td><td></td><td></td><td></td><td></td><td></td><td>39</td><td>37</td><td>35</td><td>33</td><td></td><td></td><td></td></tr> <tr><td></td><td>73</td><td></td><td></td><td></td><td>29</td><td></td><td></td><td></td><td>23</td><td>21</td><td></td><td></td><td></td><td></td><td>17</td></tr> <tr><td></td><td></td><td></td><td>15</td><td></td><td>12</td><td></td><td></td><td></td><td>7</td><td>6</td><td>5</td><td>4</td><td>3</td><td></td><td></td><td></td></tr> </table>										59	57	55	53					50	48	46						39	37	35	33					73				29				23	21					17				15		12				7	6	5	4	3				
									59	57	55	53																																																													
	50	48	46						39	37	35	33																																																													
	73				29				23	21					17																																																										
			15		12				7	6	5	4	3																																																												
AVAILABLE	NOT APPLICABLE	34566-1253	G	9	B	ST GRY	<table border="1"> <tr><td></td><td></td><td>49</td><td>48</td><td>46</td><td>65</td><td></td><td></td><td>60</td><td>59</td><td>57</td><td>55</td><td>53</td><td></td><td></td><td></td></tr> <tr><td></td><td></td><td></td><td></td><td></td><td></td><td></td><td></td><td>40</td><td>39</td><td>37</td><td>35</td><td>33</td><td></td><td></td><td></td></tr> <tr><td></td><td>73</td><td></td><td></td><td></td><td></td><td></td><td></td><td>24</td><td>23</td><td>21</td><td></td><td></td><td></td><td></td><td>2</td><td></td></tr> </table>			49	48	46	65			60	59	57	55	53												40	39	37	35	33					73							24	23	21					2																		
		49	48	46	65			60	59	57	55	53																																																													
								40	39	37	35	33																																																													
	73							24	23	21					2																																																										
AVAILABLE	NOT APPLICABLE	34566-1263	G	9	A	BLACK	<p>NUMBERS IN BOLD MUST USE SAE WIRE MEETING SAE J1128, WIRE SIZE (NO.20) OR (NO.18 MAX. O.D. OF 2.06 MM) PER G.M. DRAWING NUMBER 12582682.</p> <table border="1"> <tr><td>72</td><td>71</td><td>69</td><td>68</td><td>67</td><td>66</td><td>64</td><td>63</td><td>62</td><td></td><td>59</td><td></td><td>56</td><td></td><td>53</td></tr> <tr><td></td><td>50</td><td></td><td>48</td><td></td><td>46</td><td>44</td><td>43</td><td>42</td><td></td><td>39</td><td></td><td>36</td><td>35</td><td>33</td></tr> <tr><td></td><td>73</td><td></td><td>32</td><td></td><td>30</td><td>29</td><td>27</td><td></td><td></td><td>24</td><td>23</td><td></td><td>20</td><td>17</td></tr> <tr><td></td><td></td><td></td><td></td><td>14</td><td>13</td><td>12</td><td>11</td><td>9</td><td>8</td><td></td><td></td><td>5</td><td>4</td><td>3</td><td>2</td><td>1</td></tr> </table>	72	71	69	68	67	66	64	63	62		59		56		53		50		48		46	44	43	42		39		36	35	33		73		32		30	29	27			24	23		20	17					14	13	12	11	9	8			5	4	3	2	1				
72	71	69	68	67	66	64	63	62		59		56		53																																																											
	50		48		46	44	43	42		39		36	35	33																																																											
	73		32		30	29	27			24	23		20	17																																																											
				14	13	12	11	9	8			5	4	3	2	1																																																									
AVAILABLE	NOT APPLICABLE	34566-1273	G	0	A	BLACK	<table border="1"> <tr><td></td><td>70</td><td>69</td><td>68</td><td></td><td>65</td><td>64</td><td>63</td><td>61</td><td>59</td><td>58</td><td>57</td><td>56</td><td></td><td></td><td></td></tr> <tr><td>52</td><td>50</td><td>49</td><td>48</td><td>47</td><td></td><td></td><td></td><td>41</td><td></td><td>38</td><td>37</td><td>36</td><td>34</td><td>33</td><td></td></tr> <tr><td></td><td>73</td><td></td><td>32</td><td>31</td><td>30</td><td>29</td><td>28</td><td>27</td><td></td><td>24</td><td>23</td><td></td><td>20</td><td>19</td><td>18</td><td></td></tr> <tr><td></td><td></td><td></td><td>16</td><td></td><td></td><td>13</td><td>12</td><td>11</td><td>10</td><td>9</td><td></td><td></td><td></td><td></td><td></td><td>1</td></tr> </table>		70	69	68		65	64	63	61	59	58	57	56				52	50	49	48	47				41		38	37	36	34	33			73		32	31	30	29	28	27		24	23		20	19	18					16			13	12	11	10	9						1
	70	69	68		65	64	63	61	59	58	57	56																																																													
52	50	49	48	47				41		38	37	36	34	33																																																											
	73		32	31	30	29	28	27		24	23		20	19	18																																																										
			16			13	12	11	10	9						1																																																									

ENTER DESCRIPTION ELEC NO: UAU2016-0232 DRAWN BY: 2015/08/14 CHKD: 2015/08/14 APPR: WJOSHY REV: G34	QUALITY SYMBOLS	GENERAL TOLERANCES (UNLESS SPECIFIED)	DIMENSION STYLE	SCALE	DESIGN UNITS	THIRD ANGLE PROJECTION	
	∇=0 ∇=0 ∇=0	4 PLACES ± --- INCH 3 PLACES ± --- INCH 2 PLACES ± --- INCH 1 PLACE ± --- INCH 0 PLACE ± --- INCH	mm INCH ANGULAR ± ---° DRAFT WHERE APPLICABLE MUST REMAIN WITHIN DIMENSIONS	MM ONLY DRAWN BY: SKRAJENDRANA 2011/02/14 CHECKED BY: MVANSLAMBROU 2011/02/14 APPROVED BY:	DATE: 2011/02/14 DATE: 2011/02/14 DATE:	METRIC	TITLE: MX123 66/73/80CKT HRNS CONN ASSY molex
	MATERIAL NO. SEE BOM TABLE DOCUMENT NO. SD-34566-001	SHEET NO. 17 OF 85	THIS DRAWING CONTAINS INFORMATION THAT IS PROPRIETARY TO MOLEX INCORPORATED AND SHOULD NOT BE USED WITHOUT WRITTEN PERMISSION				

STATUS	GM PART #	MATERIAL #	PART/MATERIAL REVISION	WIRE DRESS OPTION	KEY OPTION	COLOR (T/PAL)	NUMBERS INDICATE CAVITIES OPEN FOR CIRCUITS																																																																													
AVAILABLE	NOT APPLICABLE	34566-1283	G	0	A	BLACK	<table border="1"> <tr><td>72</td><td>71</td><td>70</td><td>69</td><td>68</td><td>66</td><td>65</td><td>64</td><td>63</td><td>61</td><td>59</td><td>58</td><td>57</td><td>56</td><td>54</td></tr> <tr><td>52</td><td>50</td><td>49</td><td>48</td><td>47</td><td></td><td></td><td></td><td></td><td>42</td><td>41</td><td>38</td><td>37</td><td>36</td><td>34</td><td>33</td></tr> <tr><td colspan="2">73</td><td>32</td><td>31</td><td>30</td><td>29</td><td>28</td><td>27</td><td>26</td><td>24</td><td>23</td><td></td><td></td><td>20</td><td>19</td><td>18</td></tr> <tr><td colspan="2"></td><td>16</td><td></td><td></td><td>13</td><td>12</td><td>11</td><td>10</td><td>9</td><td></td><td></td><td></td><td></td><td></td><td></td></tr> </table>	72	71	70	69	68	66	65	64	63	61	59	58	57	56	54	52	50	49	48	47					42	41	38	37	36	34	33	73		32	31	30	29	28	27	26	24	23			20	19	18			16			13	12	11	10	9																				
72	71	70	69	68	66	65	64	63	61	59	58	57	56	54																																																																						
52	50	49	48	47					42	41	38	37	36	34	33																																																																					
73		32	31	30	29	28	27	26	24	23			20	19	18																																																																					
		16			13	12	11	10	9																																																																											
AVAILABLE	NOT APPLICABLE	34566-1293	G	0	A	BLACK	<table border="1"> <tr><td></td><td></td><td></td><td>68</td><td></td><td>65</td><td>63</td><td>61</td><td>59</td><td>58</td><td>56</td><td></td><td></td><td></td><td></td><td></td></tr> <tr><td>52</td><td>50</td><td></td><td>47</td><td></td><td></td><td></td><td>41</td><td></td><td>38</td><td>37</td><td>36</td><td></td><td>34</td><td>33</td><td></td></tr> <tr><td colspan="2">73</td><td>32</td><td>31</td><td>30</td><td>29</td><td>28</td><td>27</td><td>24</td><td>23</td><td></td><td></td><td>20</td><td>19</td><td>18</td><td>17</td></tr> <tr><td colspan="2"></td><td>16</td><td></td><td></td><td>13</td><td>12</td><td>11</td><td>10</td><td>9</td><td></td><td></td><td></td><td></td><td></td><td>1</td></tr> </table>				68		65	63	61	59	58	56						52	50		47				41		38	37	36		34	33		73		32	31	30	29	28	27	24	23			20	19	18	17			16			13	12	11	10	9						1													
			68		65	63	61	59	58	56																																																																										
52	50		47				41		38	37	36		34	33																																																																						
73		32	31	30	29	28	27	24	23			20	19	18	17																																																																					
		16			13	12	11	10	9						1																																																																					
AVAILABLE	NOT APPLICABLE	34566-1313	G	0	H	ST GRAY	<table border="1"> <tr><td>80</td><td>78</td><td></td><td></td><td></td><td></td><td></td><td>72</td><td>71</td><td>70</td><td>69</td><td>68</td><td>66</td><td>65</td><td>64</td><td>63</td><td>61</td></tr> <tr><td></td><td>58</td><td>57</td><td>56</td><td>55</td><td>54</td><td>53</td><td></td><td></td><td></td><td></td><td></td><td>46</td><td>44</td><td>43</td><td>42</td><td></td></tr> <tr><td>40</td><td></td><td>37</td><td>35</td><td></td><td></td><td></td><td>32</td><td>30</td><td>29</td><td></td><td>27</td><td>26</td><td></td><td></td><td></td><td>21</td></tr> <tr><td>20</td><td>19</td><td>18</td><td>17</td><td>15</td><td></td><td></td><td>12</td><td></td><td></td><td></td><td>8</td><td>6</td><td>5</td><td>3</td><td>2</td><td></td></tr> </table>	80	78						72	71	70	69	68	66	65	64	63	61		58	57	56	55	54	53						46	44	43	42		40		37	35				32	30	29		27	26				21	20	19	18	17	15			12				8	6	5	3	2										
80	78						72	71	70	69	68	66	65	64	63	61																																																																				
	58	57	56	55	54	53						46	44	43	42																																																																					
40		37	35				32	30	29		27	26				21																																																																				
20	19	18	17	15			12				8	6	5	3	2																																																																					
AVAILABLE	NOT APPLICABLE	34566-1323	G	0	A	BLACK	<table border="1"> <tr><td>72</td><td>71</td><td>70</td><td>69</td><td>68</td><td>67</td><td>66</td><td>65</td><td>64</td><td>63</td><td>62</td><td>60</td><td>59</td><td>58</td><td>57</td><td>56</td><td>55</td><td>54</td><td>53</td></tr> <tr><td>52</td><td>51</td><td>50</td><td>49</td><td>48</td><td>47</td><td>46</td><td>45</td><td>44</td><td>43</td><td>42</td><td>41</td><td>40</td><td>39</td><td>38</td><td>37</td><td>36</td><td>35</td><td>34</td><td>33</td></tr> <tr><td colspan="2">73</td><td>32</td><td>31</td><td>30</td><td>29</td><td>28</td><td>27</td><td>25</td><td>24</td><td>23</td><td>22</td><td>21</td><td>20</td><td>19</td><td>18</td><td>17</td><td></td><td></td></tr> <tr><td colspan="2"></td><td>16</td><td>15</td><td>14</td><td>13</td><td>12</td><td>11</td><td>9</td><td>8</td><td>7</td><td>6</td><td>5</td><td>4</td><td>3</td><td>2</td><td>1</td><td></td><td></td></tr> </table>	72	71	70	69	68	67	66	65	64	63	62	60	59	58	57	56	55	54	53	52	51	50	49	48	47	46	45	44	43	42	41	40	39	38	37	36	35	34	33	73		32	31	30	29	28	27	25	24	23	22	21	20	19	18	17					16	15	14	13	12	11	9	8	7	6	5	4	3	2	1		
72	71	70	69	68	67	66	65	64	63	62	60	59	58	57	56	55	54	53																																																																		
52	51	50	49	48	47	46	45	44	43	42	41	40	39	38	37	36	35	34	33																																																																	
73		32	31	30	29	28	27	25	24	23	22	21	20	19	18	17																																																																				
		16	15	14	13	12	11	9	8	7	6	5	4	3	2	1																																																																				
AVAILABLE	NOT APPLICABLE	34566-1333	G	0	A	BLACK	<table border="1"> <tr><td></td><td></td><td>70</td><td>69</td><td>68</td><td></td><td></td><td>65</td><td>64</td><td></td><td></td><td>59</td><td>58</td><td>56</td><td></td><td></td><td></td><td></td><td></td></tr> <tr><td>52</td><td>50</td><td>49</td><td></td><td>47</td><td></td><td></td><td></td><td></td><td>41</td><td></td><td></td><td>38</td><td>37</td><td>36</td><td></td><td>34</td><td></td><td></td></tr> <tr><td colspan="2">73</td><td>32</td><td>31</td><td>30</td><td>29</td><td>28</td><td>27</td><td></td><td>23</td><td></td><td></td><td></td><td>20</td><td>19</td><td>18</td><td>17</td><td></td><td></td></tr> <tr><td colspan="2"></td><td>16</td><td></td><td></td><td>13</td><td>12</td><td>11</td><td>10</td><td>9</td><td>8</td><td>6</td><td></td><td></td><td></td><td></td><td></td><td></td><td>1</td></tr> </table>			70	69	68			65	64			59	58	56						52	50	49		47					41			38	37	36		34			73		32	31	30	29	28	27		23				20	19	18	17					16			13	12	11	10	9	8	6							1	
		70	69	68			65	64			59	58	56																																																																							
52	50	49		47					41			38	37	36		34																																																																				
73		32	31	30	29	28	27		23				20	19	18	17																																																																				
		16			13	12	11	10	9	8	6							1																																																																		
AVAILABLE	NOT APPLICABLE	34566-1343	G	0	A	BLACK	<table border="1"> <tr><td>72</td><td>71</td><td></td><td>69</td><td>67</td><td>65</td><td>64</td><td>63</td><td></td><td></td><td>59</td><td>58</td><td>57</td><td>56</td><td></td><td></td><td></td><td></td><td></td></tr> <tr><td></td><td>50</td><td>49</td><td>48</td><td>47</td><td></td><td></td><td></td><td>41</td><td></td><td></td><td>38</td><td>37</td><td>36</td><td></td><td>34</td><td></td><td></td><td></td></tr> <tr><td colspan="2">73</td><td>32</td><td>31</td><td>30</td><td>29</td><td>28</td><td>27</td><td></td><td>23</td><td></td><td></td><td>20</td><td>19</td><td>18</td><td>17</td><td></td><td></td><td></td></tr> <tr><td colspan="2"></td><td>16</td><td></td><td></td><td>13</td><td>12</td><td>11</td><td>10</td><td>9</td><td>7</td><td>6</td><td>4</td><td>3</td><td>1</td><td></td><td></td><td></td><td></td></tr> </table>	72	71		69	67	65	64	63			59	58	57	56							50	49	48	47				41			38	37	36		34				73		32	31	30	29	28	27		23			20	19	18	17						16			13	12	11	10	9	7	6	4	3	1					
72	71		69	67	65	64	63			59	58	57	56																																																																							
	50	49	48	47				41			38	37	36		34																																																																					
73		32	31	30	29	28	27		23			20	19	18	17																																																																					
		16			13	12	11	10	9	7	6	4	3	1																																																																						
AVAILABLE	NOT APPLICABLE	34566-1353	G	0	H	ST GRAY	<table border="1"> <tr><td></td><td>79</td><td>78</td><td>77</td><td>76</td><td>75</td><td>74</td><td>73</td><td>72</td><td>71</td><td>70</td><td>69</td><td>68</td><td>66</td><td>65</td><td>64</td><td>63</td><td>61</td></tr> <tr><td>60</td><td>59</td><td>58</td><td>57</td><td>56</td><td></td><td></td><td>53</td><td></td><td>50</td><td></td><td></td><td></td><td></td><td>44</td><td>43</td><td>41</td><td></td></tr> <tr><td>40</td><td>39</td><td>38</td><td>37</td><td></td><td>35</td><td>34</td><td></td><td>32</td><td>30</td><td>29</td><td></td><td>27</td><td>26</td><td></td><td></td><td>22</td><td>21</td></tr> <tr><td>20</td><td>19</td><td>18</td><td>17</td><td></td><td></td><td></td><td>13</td><td>12</td><td>11</td><td></td><td></td><td>8</td><td>6</td><td>5</td><td>3</td><td>2</td><td></td></tr> </table>		79	78	77	76	75	74	73	72	71	70	69	68	66	65	64	63	61	60	59	58	57	56			53		50					44	43	41		40	39	38	37		35	34		32	30	29		27	26			22	21	20	19	18	17				13	12	11			8	6	5	3	2						
	79	78	77	76	75	74	73	72	71	70	69	68	66	65	64	63	61																																																																			
60	59	58	57	56			53		50					44	43	41																																																																				
40	39	38	37		35	34		32	30	29		27	26			22	21																																																																			
20	19	18	17				13	12	11			8	6	5	3	2																																																																				
AVAILABLE	NOT APPLICABLE	34566-1363	G	0	A	BLACK	<table border="1"> <tr><td>72</td><td>71</td><td></td><td>69</td><td>68</td><td>67</td><td>66</td><td>64</td><td>63</td><td>62</td><td></td><td>59</td><td></td><td></td><td></td><td></td><td></td><td></td><td>53</td></tr> <tr><td></td><td></td><td></td><td>48</td><td>46</td><td>44</td><td>43</td><td>42</td><td></td><td></td><td></td><td>39</td><td></td><td></td><td></td><td></td><td></td><td></td><td>33</td></tr> <tr><td colspan="2">73</td><td>32</td><td></td><td>29</td><td>27</td><td></td><td></td><td></td><td></td><td>24</td><td>23</td><td></td><td></td><td></td><td></td><td></td><td></td><td>17</td></tr> <tr><td colspan="2"></td><td></td><td></td><td>14</td><td>13</td><td>12</td><td>11</td><td>9</td><td>8</td><td></td><td></td><td></td><td>5</td><td>4</td><td>3</td><td>2</td><td>1</td><td></td></tr> </table>	72	71		69	68	67	66	64	63	62		59							53				48	46	44	43	42				39							33	73		32		29	27					24	23							17					14	13	12	11	9	8				5	4	3	2	1		
72	71		69	68	67	66	64	63	62		59							53																																																																		
			48	46	44	43	42				39							33																																																																		
73		32		29	27					24	23							17																																																																		
				14	13	12	11	9	8				5	4	3	2	1																																																																			

ENTER DESCRIPTION ELEC NO: JAU2016-0232 DRAWN BY: 2015/08/14 CHKD: APPR: IKOSHY 2015/08/14 REV: G34	QUALITY SYMBOLS	GENERAL TOLERANCES (UNLESS SPECIFIED)	DIMENSION STYLE	SCALE	DESIGN UNITS	THIRD ANGLE PROJECTION	
	$\nabla=0$ $\nabla=0$ $\nabla=0$	4 PLACES #--- #--- 3 PLACES #--- #--- 2 PLACES #--- #--- 1 PLACE #--- #--- 0 PLACE #--- #---	mm INCH #--- #--- #--- #--- #--- #--- #--- #--- #--- #---	MM ONLY		METRIC	
		ANGULAR ±---° DRAFT WHERE APPLICABLE MUST REMAIN WITHIN DIMENSIONS	DRAWN BY: SKRAJENDRANA 2011/02/14 CHECKED BY: DATE MVANSLAMBROU 2011/02/14 APPROVED BY: DATE	TITLE		MX123 66/73/80CKT HRNS CONN ASSY molex	
				SEE BOM TABLE	MATERIAL NO.	DOCUMENT NO.	SHEET NO.
					SD-34566-001	18 OF 85	

STATUS	GM PART #	MATERIAL #	PART/MATERIAL REVISION	WIRE DRESS OPTION	KEY OPTION	COLOR (TPA)	NUMBERS INDICATE CAVITIES OPEN FOR CIRCUITS																																																																			
AVAILABLE	NOT APPLICABLE	34566-1473	G	0	A	BLACK	<table border="1"> <tr><td>72</td><td>71</td><td>69</td><td>68</td><td>67</td><td>66</td><td>64</td><td>63</td><td>62</td><td>59</td><td>58</td><td>56</td><td>54</td><td>53</td></tr> <tr><td>52</td><td></td><td>49</td><td>48</td><td>46</td><td>44</td><td>43</td><td>42</td><td></td><td>39</td><td></td><td></td><td>34</td><td>33</td></tr> <tr><td></td><td>73</td><td></td><td>32</td><td></td><td>29</td><td>27</td><td></td><td>24</td><td>23</td><td></td><td></td><td></td><td>17</td></tr> <tr><td></td><td></td><td></td><td></td><td>14</td><td>13</td><td>12</td><td>11</td><td>9</td><td>8</td><td>7</td><td>6</td><td>5</td><td>4</td><td>3</td><td>2</td><td>1</td></tr> </table>	72	71	69	68	67	66	64	63	62	59	58	56	54	53	52		49	48	46	44	43	42		39			34	33		73		32		29	27		24	23				17					14	13	12	11	9	8	7	6	5	4	3	2	1								
72	71	69	68	67	66	64	63	62	59	58	56	54	53																																																													
52		49	48	46	44	43	42		39			34	33																																																													
	73		32		29	27		24	23				17																																																													
				14	13	12	11	9	8	7	6	5	4	3	2	1																																																										
AVAILABLE	NOT APPLICABLE	34566-1483	G	0	A	BLACK	<table border="1"> <tr><td>72</td><td>71</td><td>69</td><td>68</td><td></td><td>65</td><td>64</td><td>63</td><td>61</td><td>59</td><td>58</td><td>56</td><td></td><td></td></tr> <tr><td>52</td><td></td><td>50</td><td>49</td><td></td><td>47</td><td></td><td></td><td>41</td><td></td><td></td><td>38</td><td>37</td><td>34</td><td>33</td></tr> <tr><td></td><td>73</td><td></td><td>32</td><td>31</td><td>30</td><td>29</td><td>28</td><td>27</td><td></td><td>24</td><td>23</td><td></td><td>20</td><td>19</td><td>18</td><td>17</td></tr> <tr><td></td><td></td><td></td><td>16</td><td></td><td></td><td>13</td><td>12</td><td>11</td><td>10</td><td>9</td><td></td><td></td><td></td><td></td><td></td><td>1</td></tr> </table>	72	71	69	68		65	64	63	61	59	58	56			52		50	49		47			41			38	37	34	33		73		32	31	30	29	28	27		24	23		20	19	18	17				16			13	12	11	10	9						1				
72	71	69	68		65	64	63	61	59	58	56																																																															
52		50	49		47			41			38	37	34	33																																																												
	73		32	31	30	29	28	27		24	23		20	19	18	17																																																										
			16			13	12	11	10	9						1																																																										
AVAILABLE	NOT APPLICABLE	34566-1493	G	0	B	ST GRAY	<table border="1"> <tr><td></td><td></td><td></td><td>68</td><td></td><td></td><td></td><td></td><td></td><td>59</td><td>58</td><td>57</td><td>55</td><td>53</td></tr> <tr><td></td><td></td><td>49</td><td>48</td><td>46</td><td></td><td></td><td></td><td></td><td>39</td><td>38</td><td>37</td><td>35</td><td>33</td></tr> <tr><td></td><td>73</td><td></td><td></td><td></td><td>29</td><td></td><td></td><td></td><td>23</td><td>22</td><td>21</td><td></td><td>18</td><td>17</td></tr> <tr><td></td><td></td><td></td><td></td><td></td><td>12</td><td>11</td><td>10</td><td></td><td>7</td><td></td><td></td><td></td><td></td><td></td><td></td><td>1</td></tr> </table>				68						59	58	57	55	53			49	48	46					39	38	37	35	33		73				29				23	22	21		18	17						12	11	10		7							1							
			68						59	58	57	55	53																																																													
		49	48	46					39	38	37	35	33																																																													
	73				29				23	22	21		18	17																																																												
					12	11	10		7							1																																																										
AVAILABLE	NOT APPLICABLE	34566-1513	G	0	B	ST GRAY	<table border="1"> <tr><td></td><td></td><td></td><td></td><td></td><td>65</td><td></td><td></td><td></td><td>59</td><td>57</td><td>55</td><td>53</td></tr> <tr><td></td><td></td><td>49</td><td>48</td><td>46</td><td></td><td></td><td></td><td></td><td>39</td><td>37</td><td>35</td><td>33</td></tr> <tr><td></td><td>73</td><td></td><td></td><td></td><td>29</td><td></td><td></td><td></td><td>23</td><td>21</td><td></td><td>17</td></tr> <tr><td></td><td></td><td></td><td></td><td></td><td>12</td><td></td><td></td><td></td><td>7</td><td></td><td></td><td></td><td></td><td></td><td></td><td></td></tr> </table>						65				59	57	55	53			49	48	46					39	37	35	33		73				29				23	21		17						12				7																		
					65				59	57	55	53																																																														
		49	48	46					39	37	35	33																																																														
	73				29				23	21		17																																																														
					12				7																																																																	
AVAILABLE	NOT APPLICABLE	34566-1523	G	0	A	BLACK	<table border="1"> <tr><td></td><td>70</td><td>69</td><td>68</td><td></td><td>65</td><td>64</td><td></td><td></td><td>59</td><td>58</td><td>56</td><td>54</td></tr> <tr><td>52</td><td>50</td><td>49</td><td></td><td>47</td><td></td><td></td><td>42</td><td>41</td><td></td><td></td><td>38</td><td>37</td><td>36</td><td>34</td></tr> <tr><td></td><td>73</td><td></td><td>32</td><td>31</td><td>30</td><td>29</td><td>28</td><td>27</td><td>26</td><td></td><td>23</td><td></td><td>20</td><td>19</td><td>18</td><td>17</td></tr> <tr><td></td><td></td><td></td><td>16</td><td></td><td></td><td>13</td><td>12</td><td>11</td><td>10</td><td>9</td><td>8</td><td></td><td></td><td></td><td></td><td>1</td></tr> </table>		70	69	68		65	64			59	58	56	54	52	50	49		47			42	41			38	37	36	34		73		32	31	30	29	28	27	26		23		20	19	18	17				16			13	12	11	10	9	8					1					
	70	69	68		65	64			59	58	56	54																																																														
52	50	49		47			42	41			38	37	36	34																																																												
	73		32	31	30	29	28	27	26		23		20	19	18	17																																																										
			16			13	12	11	10	9	8					1																																																										
AVAILABLE	NOT APPLICABLE	34566-1533	G	0	A	BLACK	<table border="1"> <tr><td>72</td><td>71</td><td>70</td><td>69</td><td>68</td><td></td><td>65</td><td>64</td><td>63</td><td>61</td><td>59</td><td>58</td><td>57</td><td>56</td><td></td><td></td></tr> <tr><td>52</td><td>51</td><td>50</td><td>49</td><td></td><td>47</td><td></td><td></td><td></td><td>41</td><td></td><td></td><td>38</td><td>37</td><td>36</td><td>34</td><td>33</td></tr> <tr><td></td><td>73</td><td></td><td>32</td><td>31</td><td>30</td><td>29</td><td>28</td><td>27</td><td></td><td>24</td><td>23</td><td></td><td>20</td><td>19</td><td>18</td><td>17</td></tr> <tr><td></td><td></td><td></td><td>16</td><td></td><td></td><td>13</td><td>12</td><td>11</td><td>10</td><td>9</td><td></td><td></td><td></td><td>3</td><td>2</td><td>1</td></tr> </table>	72	71	70	69	68		65	64	63	61	59	58	57	56			52	51	50	49		47				41			38	37	36	34	33		73		32	31	30	29	28	27		24	23		20	19	18	17				16			13	12	11	10	9				3	2	1
72	71	70	69	68		65	64	63	61	59	58	57	56																																																													
52	51	50	49		47				41			38	37	36	34	33																																																										
	73		32	31	30	29	28	27		24	23		20	19	18	17																																																										
			16			13	12	11	10	9				3	2	1																																																										
AVAILABLE	NOT APPLICABLE	34566-1543	G	0	B	ST GRAY	<table border="1"> <tr><td></td><td></td><td>69</td><td>68</td><td>66</td><td></td><td></td><td></td><td></td><td>59</td><td>57</td><td>55</td><td>53</td></tr> <tr><td></td><td></td><td>49</td><td>48</td><td>46</td><td></td><td></td><td></td><td></td><td>39</td><td>37</td><td>35</td><td>33</td></tr> <tr><td></td><td>73</td><td></td><td></td><td></td><td>29</td><td></td><td></td><td></td><td>23</td><td>21</td><td></td><td></td></tr> <tr><td></td><td></td><td></td><td></td><td></td><td></td><td>11</td><td>10</td><td></td><td>7</td><td></td><td></td><td></td><td></td><td></td><td></td><td></td></tr> </table>			69	68	66					59	57	55	53			49	48	46					39	37	35	33		73				29				23	21									11	10		7																		
		69	68	66					59	57	55	53																																																														
		49	48	46					39	37	35	33																																																														
	73				29				23	21																																																																
						11	10		7																																																																	
AVAILABLE	NOT APPLICABLE	34566-1583	G	0	A	BLACK	<table border="1"> <tr><td></td><td>70</td><td></td><td>67</td><td>66</td><td>65</td><td></td><td></td><td>61</td><td></td><td>58</td><td>57</td><td>55</td><td>54</td></tr> <tr><td></td><td></td><td>49</td><td></td><td>47</td><td>45</td><td>44</td><td>43</td><td>42</td><td>41</td><td>39</td><td>37</td><td></td><td>34</td></tr> <tr><td></td><td>73</td><td></td><td>32</td><td>30</td><td></td><td>27</td><td>25</td><td>24</td><td></td><td>21</td><td>20</td><td>19</td><td>18</td><td>17</td></tr> <tr><td></td><td></td><td></td><td>15</td><td></td><td>13</td><td></td><td>11</td><td>9</td><td>8</td><td>6</td><td>5</td><td></td><td>3</td><td>2</td><td>1</td></tr> </table>		70		67	66	65			61		58	57	55	54			49		47	45	44	43	42	41	39	37		34		73		32	30		27	25	24		21	20	19	18	17				15		13		11	9	8	6	5		3	2	1								
	70		67	66	65			61		58	57	55	54																																																													
		49		47	45	44	43	42	41	39	37		34																																																													
	73		32	30		27	25	24		21	20	19	18	17																																																												
			15		13		11	9	8	6	5		3	2	1																																																											

ENTER DESCRIPTION EC NO: UAU2016-0232 DRAWN BY: 2015/08/14 CHKD: 2015/08/14 APPR: IKOSHY REV:	QUALITY SYMBOLS	GENERAL TOLERANCES (UNLESS SPECIFIED)	DIMENSION STYLE	SCALE	DESIGN UNITS	THIRD ANGLE PROJECTION
	▽=0	mm INCH	MM ONLY		METRIC	
	▽=0	4 PLACES ±	DRAWN BY: SKRAJENDRANA 2011/02/14	DATE: 2011/02/14	TITLE: MX123 66/73/80CKT HRNS CONN ASSY	
	▽=0	3 PLACES ±	CHECKED BY: MYANSLAMBROU 2011/02/14	DATE: 2011/02/14	APPROVED BY: DATE:	
	ANGULAR ±	DRAFT WHERE APPLICABLE MUST REMAIN WITHIN DIMENSIONS	SEE BOM TABLE	MATERIAL NO. SD-34566-001	DOCUMENT NO. SD-34566-001	SHEET NO. 20 OF 85
			THIS DRAWING CONTAINS INFORMATION THAT IS PROPRIETARY TO MOLEX INCORPORATED AND SHOULD NOT BE USED WITHOUT WRITTEN PERMISSION			

STATUS	GM PART #	MATERIAL #	PART/MATERIAL REVISION	WIRE DRESS OPTION	KEY OPTION	COLOR (TFA)	NUMBERS INDICATE CAVITIES OPEN FOR CIRCUITS																																																																																																					
AVAILABLE	NOT APPLICABLE	34566-1873	G	0	C	BLUE	<table border="1"> <tr><td>72</td><td>70</td><td></td><td></td><td>67</td><td>66</td><td></td><td></td><td>63</td><td>62</td><td></td><td></td><td>59</td><td>57</td><td></td><td></td><td></td><td></td><td></td><td>53</td></tr> <tr><td>52</td><td>51</td><td></td><td></td><td></td><td>46</td><td></td><td>44</td><td></td><td>42</td><td></td><td>40</td><td>39</td><td></td><td></td><td></td><td></td><td></td><td></td><td>34</td><td>33</td></tr> <tr><td></td><td></td><td>73</td><td></td><td>32</td><td>30</td><td></td><td></td><td>27</td><td>26</td><td>25</td><td></td><td></td><td>22</td><td>21</td><td>20</td><td></td><td></td><td></td><td></td></tr> <tr><td></td><td></td><td></td><td></td><td>15</td><td>14</td><td></td><td></td><td></td><td>10</td><td>9</td><td></td><td></td><td>6</td><td>5</td><td>4</td><td></td><td></td><td></td><td></td></tr> </table>																72	70			67	66			63	62			59	57						53	52	51				46		44		42		40	39							34	33			73		32	30			27	26	25			22	21	20									15	14				10	9			6	5	4									
72	70			67	66			63	62			59	57						53																																																																																									
52	51				46		44		42		40	39							34	33																																																																																								
		73		32	30			27	26	25			22	21	20																																																																																													
				15	14				10	9			6	5	4																																																																																													
AVAILABLE	NOT APPLICABLE	34566-1883	G	0	A	BLACK	<table border="1"> <tr><td></td><td>70</td><td></td><td></td><td>68</td><td>67</td><td>66</td><td>65</td><td></td><td></td><td></td><td></td><td></td><td>58</td><td>57</td><td></td><td></td><td></td><td></td><td>55</td></tr> <tr><td></td><td></td><td>49</td><td></td><td>47</td><td></td><td></td><td></td><td>44</td><td>43</td><td>42</td><td>41</td><td>40</td><td>39</td><td></td><td>37</td><td></td><td></td><td>35</td><td></td></tr> <tr><td></td><td></td><td></td><td>73</td><td>32</td><td>30</td><td></td><td></td><td>27</td><td>25</td><td>24</td><td></td><td></td><td></td><td>21</td><td>20</td><td>19</td><td>18</td><td>17</td><td></td></tr> <tr><td></td><td></td><td></td><td></td><td>16</td><td>15</td><td></td><td>13</td><td></td><td>10</td><td>9</td><td>8</td><td></td><td>6</td><td>5</td><td></td><td>3</td><td>2</td><td>1</td><td></td></tr> </table>																	70			68	67	66	65						58	57					55			49		47				44	43	42	41	40	39		37			35					73	32	30			27	25	24				21	20	19	18	17						16	15		13		10	9	8		6	5		3	2	1							
	70			68	67	66	65						58	57					55																																																																																									
		49		47				44	43	42	41	40	39		37			35																																																																																										
			73	32	30			27	25	24				21	20	19	18	17																																																																																										
				16	15		13		10	9	8		6	5		3	2	1																																																																																										
AVAILABLE	NOT APPLICABLE	34566-1893	G	0	C	BLUE	<table border="1"> <tr><td>72</td><td>70</td><td></td><td></td><td></td><td>66</td><td></td><td></td><td>63</td><td></td><td></td><td></td><td>59</td><td>57</td><td></td><td></td><td></td><td></td><td></td><td>53</td></tr> <tr><td>52</td><td>51</td><td></td><td></td><td></td><td>46</td><td></td><td>44</td><td></td><td>42</td><td></td><td>40</td><td>39</td><td></td><td></td><td></td><td></td><td></td><td></td><td>34</td><td>33</td></tr> <tr><td></td><td></td><td>73</td><td></td><td>32</td><td>30</td><td></td><td></td><td>27</td><td>26</td><td>25</td><td></td><td></td><td>22</td><td>21</td><td>20</td><td></td><td></td><td></td><td></td></tr> <tr><td></td><td></td><td></td><td></td><td>15</td><td>14</td><td></td><td></td><td></td><td>10</td><td>9</td><td></td><td></td><td>6</td><td>5</td><td>4</td><td></td><td></td><td></td><td></td></tr> </table>																72	70				66			63				59	57						53	52	51				46		44		42		40	39							34	33			73		32	30			27	26	25			22	21	20									15	14				10	9			6	5	4									
72	70				66			63				59	57						53																																																																																									
52	51				46		44		42		40	39							34	33																																																																																								
		73		32	30			27	26	25			22	21	20																																																																																													
				15	14				10	9			6	5	4																																																																																													
AVAILABLE	NOT APPLICABLE	34566-1913	G	0	B	ST GRAY	<table border="1"> <tr><td>72</td><td>70</td><td>68</td><td>66</td><td></td><td></td><td></td><td></td><td></td><td></td><td></td><td>60</td><td>59</td><td></td><td></td><td></td><td></td><td></td><td>55</td><td>54</td><td>53</td></tr> <tr><td>52</td><td>50</td><td>48</td><td>46</td><td></td><td></td><td></td><td></td><td></td><td></td><td></td><td></td><td>40</td><td>39</td><td></td><td></td><td></td><td></td><td></td><td>35</td><td>34</td><td>33</td></tr> <tr><td></td><td></td><td>73</td><td></td><td>32</td><td>31</td><td>30</td><td>29</td><td>28</td><td>27</td><td>26</td><td>25</td><td>24</td><td></td><td></td><td></td><td></td><td></td><td></td><td></td><td></td></tr> <tr><td></td><td></td><td></td><td></td><td>16</td><td></td><td></td><td></td><td></td><td></td><td>10</td><td>9</td><td>8</td><td></td><td></td><td></td><td></td><td></td><td></td><td></td><td></td></tr> </table>																72	70	68	66								60	59						55	54	53	52	50	48	46									40	39						35	34	33			73		32	31	30	29	28	27	26	25	24													16						10	9	8									
72	70	68	66								60	59						55	54	53																																																																																								
52	50	48	46									40	39						35	34	33																																																																																							
		73		32	31	30	29	28	27	26	25	24																																																																																																
				16						10	9	8																																																																																																
AVAILABLE	NOT APPLICABLE	34566-1923	G	0	A	BLACK	<table border="1"> <tr><td></td><td></td><td>69</td><td></td><td></td><td></td><td></td><td></td><td>63</td><td></td><td></td><td></td><td></td><td></td><td>58</td><td>56</td><td>55</td><td>54</td><td>53</td><td></td></tr> <tr><td>52</td><td>51</td><td></td><td></td><td></td><td></td><td></td><td></td><td>44</td><td>43</td><td>42</td><td>41</td><td></td><td></td><td></td><td></td><td></td><td></td><td>36</td><td>35</td><td>34</td><td>33</td></tr> <tr><td></td><td></td><td></td><td>73</td><td>32</td><td></td><td></td><td></td><td>28</td><td>26</td><td></td><td></td><td></td><td></td><td></td><td></td><td></td><td></td><td></td><td>19</td><td>18</td><td></td></tr> <tr><td></td><td></td><td></td><td></td><td>16</td><td></td><td></td><td></td><td>12</td><td>10</td><td></td><td></td><td></td><td></td><td></td><td></td><td></td><td></td><td></td><td>3</td><td></td><td></td></tr> </table>																		69						63						58	56	55	54	53		52	51							44	43	42	41							36	35	34	33				73	32				28	26										19	18						16				12	10										3		
		69						63						58	56	55	54	53																																																																																										
52	51							44	43	42	41							36	35	34	33																																																																																							
			73	32				28	26										19	18																																																																																								
				16				12	10										3																																																																																									
AVAILABLE	NOT APPLICABLE	34566-1933	G	0	A	BLACK	<table border="1"> <tr><td></td><td>70</td><td></td><td></td><td>67</td><td>66</td><td>65</td><td></td><td></td><td></td><td></td><td></td><td></td><td>58</td><td>57</td><td></td><td></td><td></td><td></td><td>55</td></tr> <tr><td></td><td></td><td>49</td><td></td><td>47</td><td></td><td></td><td></td><td>44</td><td>43</td><td>42</td><td>41</td><td>40</td><td>39</td><td></td><td>37</td><td></td><td></td><td>35</td><td></td></tr> <tr><td></td><td></td><td></td><td>73</td><td>32</td><td>30</td><td></td><td></td><td>27</td><td>27</td><td>25</td><td>24</td><td></td><td></td><td>21</td><td>20</td><td>19</td><td>18</td><td>17</td><td></td></tr> <tr><td></td><td></td><td></td><td></td><td>16</td><td>15</td><td></td><td>13</td><td></td><td>10</td><td>9</td><td>8</td><td></td><td>6</td><td>5</td><td></td><td>3</td><td>2</td><td>1</td><td></td></tr> </table>																	70			67	66	65							58	57					55			49		47				44	43	42	41	40	39		37			35					73	32	30			27	27	25	24			21	20	19	18	17						16	15		13		10	9	8		6	5		3	2	1							
	70			67	66	65							58	57					55																																																																																									
		49		47				44	43	42	41	40	39		37			35																																																																																										
			73	32	30			27	27	25	24			21	20	19	18	17																																																																																										
				16	15		13		10	9	8		6	5		3	2	1																																																																																										
AVAILABLE	NOT APPLICABLE	34566-1943	G	0	A	BLACK	<table border="1"> <tr><td></td><td>70</td><td></td><td></td><td>67</td><td>66</td><td>65</td><td></td><td></td><td></td><td></td><td></td><td></td><td>58</td><td>57</td><td></td><td></td><td></td><td></td><td>55</td></tr> <tr><td>51</td><td>49</td><td></td><td></td><td>47</td><td></td><td></td><td></td><td>44</td><td>43</td><td>42</td><td>41</td><td>40</td><td>39</td><td></td><td>37</td><td></td><td></td><td>35</td><td></td></tr> <tr><td></td><td></td><td>73</td><td></td><td>32</td><td>30</td><td></td><td></td><td>27</td><td>25</td><td>24</td><td></td><td></td><td></td><td>21</td><td>20</td><td>19</td><td>18</td><td>17</td><td></td></tr> <tr><td></td><td></td><td></td><td></td><td>16</td><td>15</td><td></td><td>13</td><td></td><td>10</td><td>9</td><td>8</td><td></td><td>6</td><td>5</td><td></td><td>3</td><td>2</td><td>1</td><td></td></tr> </table>																	70			67	66	65							58	57					55	51	49			47				44	43	42	41	40	39		37			35				73		32	30			27	25	24				21	20	19	18	17						16	15		13		10	9	8		6	5		3	2	1							
	70			67	66	65							58	57					55																																																																																									
51	49			47				44	43	42	41	40	39		37			35																																																																																										
		73		32	30			27	25	24				21	20	19	18	17																																																																																										
				16	15		13		10	9	8		6	5		3	2	1																																																																																										
AVAILABLE	NOT APPLICABLE	34566-1953	G	0	C	BLUE	<table border="1"> <tr><td>72</td><td>70</td><td></td><td></td><td></td><td>66</td><td></td><td></td><td>63</td><td></td><td></td><td></td><td>59</td><td>57</td><td></td><td></td><td></td><td></td><td></td><td>53</td></tr> <tr><td>52</td><td>51</td><td></td><td></td><td>48</td><td>47</td><td>46</td><td></td><td>44</td><td></td><td>42</td><td></td><td>40</td><td>39</td><td></td><td></td><td></td><td></td><td></td><td>34</td><td>33</td></tr> <tr><td></td><td></td><td>73</td><td></td><td></td><td>30</td><td></td><td></td><td>26</td><td>25</td><td></td><td></td><td></td><td>22</td><td>21</td><td>20</td><td></td><td></td><td></td><td></td></tr> <tr><td></td><td></td><td></td><td></td><td>15</td><td>14</td><td></td><td></td><td></td><td>10</td><td>9</td><td></td><td></td><td>6</td><td>5</td><td>4</td><td></td><td></td><td></td><td></td></tr> </table>																72	70				66			63				59	57						53	52	51			48	47	46		44		42		40	39						34	33			73			30			26	25				22	21	20									15	14				10	9			6	5	4									
72	70				66			63				59	57						53																																																																																									
52	51			48	47	46		44		42		40	39						34	33																																																																																								
		73			30			26	25				22	21	20																																																																																													
				15	14				10	9			6	5	4																																																																																													
AVAILABLE	NOT APPLICABLE	34566-1963	G	0	C	BLUE	<table border="1"> <tr><td>72</td><td>70</td><td></td><td></td><td></td><td>66</td><td></td><td></td><td>63</td><td></td><td></td><td></td><td>59</td><td>57</td><td></td><td></td><td></td><td></td><td></td><td>53</td></tr> <tr><td>52</td><td>51</td><td></td><td></td><td></td><td>46</td><td></td><td>44</td><td></td><td>42</td><td></td><td>40</td><td>39</td><td></td><td></td><td></td><td></td><td></td><td></td><td>34</td><td>33</td></tr> <tr><td></td><td></td><td>73</td><td></td><td></td><td>30</td><td></td><td></td><td>26</td><td>25</td><td></td><td></td><td></td><td>22</td><td>21</td><td>20</td><td></td><td></td><td></td><td></td></tr> <tr><td></td><td></td><td></td><td></td><td>15</td><td>14</td><td></td><td></td><td></td><td>10</td><td>9</td><td></td><td></td><td>6</td><td>5</td><td>4</td><td></td><td></td><td></td><td></td></tr> </table>																72	70				66			63				59	57						53	52	51				46		44		42		40	39							34	33			73			30			26	25				22	21	20									15	14				10	9			6	5	4									
72	70				66			63				59	57						53																																																																																									
52	51				46		44		42		40	39							34	33																																																																																								
		73			30			26	25				22	21	20																																																																																													
				15	14				10	9			6	5	4																																																																																													

ENTER DESCRIPTION EC NO: UAU2016-0232 DRAWN BY: SKRAJENDRANA CHKD: MVANSLAMBROU APPR: WOSHY REV: 034	QUALITY SYMBOLS ∇=0 ∇=0 ∇=0	GENERAL TOLERANCES (UNLESS SPECIFIED) <table border="1"> <tr><th>mm</th><th>INCH</th></tr> <tr><td>4 PLACES ±----</td><td>±----</td></tr> <tr><td>3 PLACES ±----</td><td>±----</td></tr> <tr><td>2 PLACES ±----</td><td>±----</td></tr> <tr><td>1 PLACE ±----</td><td>±----</td></tr> <tr><td>0 PLACE ±----</td><td>±----</td></tr> </table>	mm	INCH	4 PLACES ±----	±----	3 PLACES ±----	±----	2 PLACES ±----	±----	1 PLACE ±----	±----	0 PLACE ±----	±----	DIMENSION STYLE MM ONLY	SCALE METRIC	DESIGN UNITS THIRD ANGLE PROJECTION
	mm	INCH															
	4 PLACES ±----	±----															
	3 PLACES ±----	±----															
2 PLACES ±----	±----																
1 PLACE ±----	±----																
0 PLACE ±----	±----																
DRAWN BY: SKRAJENDRANA DATE: 2011/02/14 CHECKED BY: MVANSLAMBROU DATE: 2011/02/14 APPROVED BY:	TITLE MX123 66/73/80CKT HRNS CONN ASSY	MATERIAL NO. SEE BOM TABLE	DOCUMENT NO. SD-34566-001	SHEET NO. 24 OF 85													
THIS DRAWING CONTAINS INFORMATION THAT IS PROPRIETARY TO MOLEX INCORPORATED AND SHOULD NOT BE USED WITHOUT WRITTEN PERMISSION																	

STATUS	GM PART #	MATERIAL #	PART/MATERIAL REVISION	WIRE DRESS OPTION	KEY OPTION	COLOR (TPA)	NUMBERS INDICATE CAVITIES OPEN FOR CIRCUITS																																																																															
AVAILABLE	NOT APPLICABLE	34566-1973	G	0	A	BLACK	<table border="1"> <tr><td></td><td></td><td>69</td><td></td><td></td><td></td><td>63</td><td></td><td></td><td></td><td></td><td></td><td>56</td><td>55</td><td>54</td><td>53</td></tr> <tr><td>52</td><td>51</td><td>49</td><td></td><td></td><td></td><td>44</td><td>43</td><td>42</td><td>41</td><td></td><td></td><td></td><td>36</td><td>35</td><td>34</td><td>33</td></tr> <tr><td></td><td></td><td>73</td><td></td><td>32</td><td></td><td>28</td><td>26</td><td></td><td>23</td><td></td><td>21</td><td>19</td><td>18</td><td></td><td></td></tr> <tr><td></td><td></td><td></td><td></td><td>16</td><td></td><td>12</td><td>10</td><td>8</td><td></td><td>5</td><td>3</td><td></td><td></td><td></td><td></td></tr> </table>			69				63						56	55	54	53	52	51	49				44	43	42	41				36	35	34	33			73		32		28	26		23		21	19	18							16		12	10	8		5	3																		
		69				63						56	55	54	53																																																																							
52	51	49				44	43	42	41				36	35	34	33																																																																						
		73		32		28	26		23		21	19	18																																																																									
				16		12	10	8		5	3																																																																											
AVAILABLE	NOT APPLICABLE	34566-2013	G	0	A	BLACK	<table border="1"> <tr><td></td><td>71</td><td>70</td><td></td><td></td><td></td><td>65</td><td></td><td></td><td></td><td></td><td>60</td><td>59</td><td>58</td><td>57</td><td></td><td>54</td><td>53</td></tr> <tr><td>51</td><td>50</td><td>49</td><td>48</td><td>46</td><td>45</td><td>43</td><td>41</td><td>40</td><td>39</td><td></td><td>37</td><td>36</td><td>35</td><td></td><td></td><td>33</td><td></td></tr> <tr><td></td><td></td><td>73</td><td></td><td>32</td><td>31</td><td>30</td><td></td><td></td><td></td><td>24</td><td>23</td><td>22</td><td></td><td>20</td><td></td><td></td><td></td></tr> <tr><td></td><td></td><td></td><td></td><td>16</td><td>15</td><td></td><td>13</td><td>12</td><td>11</td><td>10</td><td>9</td><td>8</td><td>7</td><td>6</td><td>5</td><td>4</td><td></td></tr> </table>		71	70				65					60	59	58	57		54	53	51	50	49	48	46	45	43	41	40	39		37	36	35			33				73		32	31	30				24	23	22		20								16	15		13	12	11	10	9	8	7	6	5	4								
	71	70				65					60	59	58	57		54	53																																																																					
51	50	49	48	46	45	43	41	40	39		37	36	35			33																																																																						
		73		32	31	30				24	23	22		20																																																																								
				16	15		13	12	11	10	9	8	7	6	5	4																																																																						
AVAILABLE	NOT APPLICABLE	34566-2023	G	0	A	BLACK	<table border="1"> <tr><td></td><td></td><td>70</td><td>68</td><td>67</td><td>66</td><td>65</td><td></td><td></td><td></td><td></td><td></td><td>58</td><td>57</td><td></td><td>55</td><td></td><td></td></tr> <tr><td></td><td></td><td>49</td><td></td><td>47</td><td></td><td></td><td>44</td><td>43</td><td>42</td><td>41</td><td>39</td><td></td><td>37</td><td></td><td>35</td><td></td><td></td></tr> <tr><td></td><td></td><td>73</td><td></td><td>32</td><td></td><td>30</td><td></td><td></td><td>27</td><td>25</td><td>24</td><td></td><td>21</td><td>20</td><td>19</td><td>18</td><td>17</td></tr> <tr><td></td><td></td><td></td><td></td><td></td><td>15</td><td></td><td>13</td><td></td><td></td><td>9</td><td>8</td><td></td><td>6</td><td>5</td><td></td><td>3</td><td>1</td></tr> </table>			70	68	67	66	65						58	57		55					49		47			44	43	42	41	39		37		35					73		32		30			27	25	24		21	20	19	18	17						15		13			9	8		6	5		3	1							
		70	68	67	66	65						58	57		55																																																																							
		49		47			44	43	42	41	39		37		35																																																																							
		73		32		30			27	25	24		21	20	19	18	17																																																																					
					15		13			9	8		6	5		3	1																																																																					
AVAILABLE	NOT APPLICABLE	34566-2033	G	0	A	BLACK	<table border="1"> <tr><td></td><td>71</td><td>70</td><td></td><td></td><td></td><td>65</td><td>64</td><td></td><td></td><td></td><td>60</td><td>59</td><td>58</td><td>57</td><td></td><td>55</td><td>54</td><td>53</td></tr> <tr><td>51</td><td>50</td><td>49</td><td>48</td><td>46</td><td>45</td><td>43</td><td>41</td><td>40</td><td>39</td><td></td><td>37</td><td>36</td><td>35</td><td></td><td></td><td>33</td><td></td><td></td></tr> <tr><td></td><td></td><td>73</td><td></td><td>32</td><td>31</td><td>30</td><td></td><td></td><td></td><td>24</td><td>23</td><td>22</td><td></td><td>20</td><td></td><td></td><td></td><td></td></tr> <tr><td></td><td></td><td></td><td></td><td>16</td><td>15</td><td></td><td>13</td><td>12</td><td>11</td><td>10</td><td>9</td><td>8</td><td>7</td><td>6</td><td>5</td><td>4</td><td>3</td><td>2</td></tr> </table>		71	70				65	64				60	59	58	57		55	54	53	51	50	49	48	46	45	43	41	40	39		37	36	35			33					73		32	31	30				24	23	22		20									16	15		13	12	11	10	9	8	7	6	5	4	3	2			
	71	70				65	64				60	59	58	57		55	54	53																																																																				
51	50	49	48	46	45	43	41	40	39		37	36	35			33																																																																						
		73		32	31	30				24	23	22		20																																																																								
				16	15		13	12	11	10	9	8	7	6	5	4	3	2																																																																				
AVAILABLE	NOT APPLICABLE	34566-2043	G	0	A	BLACK	<table border="1"> <tr><td></td><td></td><td>70</td><td></td><td>67</td><td>66</td><td>65</td><td></td><td></td><td></td><td></td><td></td><td>58</td><td>57</td><td></td><td>55</td><td></td><td></td><td></td></tr> <tr><td></td><td></td><td>49</td><td></td><td>47</td><td></td><td></td><td>44</td><td>43</td><td>42</td><td>41</td><td>39</td><td></td><td>37</td><td></td><td>35</td><td></td><td></td><td></td></tr> <tr><td></td><td></td><td>73</td><td></td><td>32</td><td></td><td>30</td><td></td><td></td><td>27</td><td>25</td><td>24</td><td></td><td>21</td><td>20</td><td>19</td><td>18</td><td>17</td><td></td></tr> <tr><td></td><td></td><td></td><td></td><td></td><td>15</td><td></td><td>13</td><td></td><td></td><td>9</td><td>8</td><td></td><td>6</td><td>5</td><td></td><td>3</td><td>1</td><td></td></tr> </table>			70		67	66	65						58	57		55						49		47			44	43	42	41	39		37		35						73		32		30			27	25	24		21	20	19	18	17							15		13			9	8		6	5		3	1				
		70		67	66	65						58	57		55																																																																							
		49		47			44	43	42	41	39		37		35																																																																							
		73		32		30			27	25	24		21	20	19	18	17																																																																					
					15		13			9	8		6	5		3	1																																																																					
AVAILABLE	NOT APPLICABLE	34566-2053	G	0	B	ST GRAY	<table border="1"> <tr><td></td><td></td><td>70</td><td>68</td><td>67</td><td>66</td><td>65</td><td></td><td></td><td></td><td></td><td></td><td>58</td><td>57</td><td></td><td>55</td><td></td><td></td><td></td></tr> <tr><td></td><td></td><td>49</td><td></td><td>47</td><td></td><td></td><td>44</td><td>43</td><td>42</td><td>41</td><td>39</td><td></td><td>37</td><td></td><td>35</td><td></td><td></td><td></td></tr> <tr><td></td><td></td><td>73</td><td></td><td>32</td><td></td><td>30</td><td></td><td></td><td>27</td><td>25</td><td>24</td><td>23</td><td>21</td><td>20</td><td>19</td><td>18</td><td></td><td></td></tr> <tr><td></td><td></td><td></td><td></td><td></td><td></td><td>13</td><td></td><td></td><td></td><td>8</td><td></td><td>6</td><td>5</td><td></td><td>3</td><td>1</td><td></td><td></td></tr> </table>			70	68	67	66	65						58	57		55						49		47			44	43	42	41	39		37		35						73		32		30			27	25	24	23	21	20	19	18									13				8		6	5		3	1					
		70	68	67	66	65						58	57		55																																																																							
		49		47			44	43	42	41	39		37		35																																																																							
		73		32		30			27	25	24	23	21	20	19	18																																																																						
						13				8		6	5		3	1																																																																						
AVAILABLE	NOT APPLICABLE	34566-2063	G	0	H	ST GRAY	<table border="1"> <tr><td></td><td></td><td></td><td>78</td><td></td><td></td><td></td><td></td><td>72</td><td>71</td><td>70</td><td>69</td><td>68</td><td></td><td>66</td><td>65</td><td>64</td><td>63</td><td>61</td></tr> <tr><td></td><td></td><td></td><td>58</td><td>57</td><td>56</td><td></td><td></td><td>53</td><td>52</td><td>51</td><td>50</td><td></td><td></td><td></td><td></td><td>44</td><td>43</td><td>41</td></tr> <tr><td></td><td></td><td></td><td>40</td><td></td><td>37</td><td>35</td><td>34</td><td></td><td>32</td><td>30</td><td>29</td><td></td><td>27</td><td>26</td><td></td><td></td><td></td><td>22</td><td>21</td></tr> <tr><td></td><td></td><td></td><td>20</td><td>19</td><td>18</td><td>17</td><td>16</td><td></td><td>14</td><td></td><td>12</td><td>10</td><td>9</td><td>8</td><td></td><td>6</td><td>5</td><td></td><td>3</td><td>2</td></tr> </table>				78					72	71	70	69	68		66	65	64	63	61				58	57	56			53	52	51	50					44	43	41				40		37	35	34		32	30	29		27	26				22	21				20	19	18	17	16		14		12	10	9	8		6	5		3	2
			78					72	71	70	69	68		66	65	64	63	61																																																																				
			58	57	56			53	52	51	50					44	43	41																																																																				
			40		37	35	34		32	30	29		27	26				22	21																																																																			
			20	19	18	17	16		14		12	10	9	8		6	5		3	2																																																																		
AVAILABLE	NOT APPLICABLE	34566-2073	G	0	H	ST GRAY	<table border="1"> <tr><td></td><td></td><td></td><td>78</td><td></td><td></td><td></td><td></td><td>72</td><td>71</td><td>70</td><td>69</td><td>68</td><td></td><td>66</td><td>65</td><td>64</td><td>63</td><td>61</td></tr> <tr><td></td><td></td><td></td><td>58</td><td>57</td><td>56</td><td></td><td></td><td>53</td><td>52</td><td>51</td><td>50</td><td></td><td></td><td></td><td></td><td>44</td><td>43</td><td>41</td></tr> <tr><td></td><td></td><td></td><td>40</td><td></td><td>37</td><td>35</td><td>34</td><td></td><td>32</td><td>30</td><td>29</td><td></td><td>27</td><td>26</td><td></td><td></td><td></td><td>22</td><td>21</td></tr> <tr><td></td><td></td><td></td><td>20</td><td>19</td><td>18</td><td>17</td><td>16</td><td></td><td>12</td><td></td><td></td><td>8</td><td></td><td>6</td><td>5</td><td></td><td>3</td><td>2</td><td></td><td></td></tr> </table>				78					72	71	70	69	68		66	65	64	63	61				58	57	56			53	52	51	50					44	43	41				40		37	35	34		32	30	29		27	26				22	21				20	19	18	17	16		12			8		6	5		3	2		
			78					72	71	70	69	68		66	65	64	63	61																																																																				
			58	57	56			53	52	51	50					44	43	41																																																																				
			40		37	35	34		32	30	29		27	26				22	21																																																																			
			20	19	18	17	16		12			8		6	5		3	2																																																																				
AVAILABLE	NOT APPLICABLE	34566-2083	G	0	H	ST GRAY	<table border="1"> <tr><td></td><td></td><td></td><td>78</td><td></td><td></td><td></td><td></td><td>72</td><td>71</td><td>70</td><td>69</td><td>68</td><td>67</td><td>66</td><td>65</td><td>64</td><td>63</td><td>61</td></tr> <tr><td></td><td></td><td></td><td>58</td><td>57</td><td>56</td><td></td><td></td><td>53</td><td>52</td><td>51</td><td>50</td><td></td><td></td><td></td><td></td><td>44</td><td>43</td><td>41</td></tr> <tr><td></td><td></td><td></td><td>40</td><td></td><td>37</td><td>35</td><td>34</td><td></td><td>32</td><td>30</td><td>29</td><td></td><td>27</td><td>26</td><td></td><td></td><td></td><td>22</td><td>21</td></tr> <tr><td></td><td></td><td></td><td>20</td><td>19</td><td>18</td><td>17</td><td>16</td><td></td><td>12</td><td></td><td></td><td>8</td><td>7</td><td>6</td><td>5</td><td></td><td>3</td><td>2</td><td>1</td><td></td></tr> </table>				78					72	71	70	69	68	67	66	65	64	63	61				58	57	56			53	52	51	50					44	43	41				40		37	35	34		32	30	29		27	26				22	21				20	19	18	17	16		12			8	7	6	5		3	2	1	
			78					72	71	70	69	68	67	66	65	64	63	61																																																																				
			58	57	56			53	52	51	50					44	43	41																																																																				
			40		37	35	34		32	30	29		27	26				22	21																																																																			
			20	19	18	17	16		12			8	7	6	5		3	2	1																																																																			

ENTER DESCRIPTION ELC NO: UAU2016-0232 DRAWN BY: DRANKITE CHKD: 2015/08/14 APPR: IKOSHY DESCRIPTION: 2015/08/14 REV: G34	QUALITY SYMBOLS ∇=0 ∇=0 ∇=0	GENERAL TOLERANCES (UNLESS SPECIFIED) mm INCH 4 PLACES ± --- ± --- 3 PLACES ± --- ± --- 2 PLACES ± --- ± --- 1 PLACE ± --- ± --- 0 PLACE ± --- ± ---	DIMENSION STYLE MM ONLY	SCALE METRIC	DESIGN UNITS METRIC	THIRD ANGLE PROJECTION
	DRAFT WHERE APPLICABLE MUST REMAIN WITHIN DIMENSIONS		DRAWN BY: SKRA JENDRANA DATE: 2011/02/14	TITLE MX123 66/73/80CKT HRNS CONN ASSY		
	MATERIAL NO. SEE BOM TABLE		CHECKED BY: MYANSLAMBROU DATE: 2011/02/14	APPROVED BY:		
	DOCUMENT NO. SD-34566-001		SHEET NO. 25 OF 85			

STATUS	GM PART #	MATERIAL #	PART/MATERIAL REVISION	WIRE DRESS OPTION	KEY OPTION	COLOR (TPA)	NUMBERS INDICATE CAVITIES OPEN FOR CIRCUITS																																																																																																						
AVAILABLE	NOT APPLICABLE	34566-2093	G	0	A	BLACK	<table border="1"> <tr><td></td><td></td><td></td><td></td><td>68</td><td></td><td></td><td>65</td><td></td><td>63</td><td></td><td>61</td><td></td><td>59</td><td>58</td><td></td><td>56</td><td></td><td></td><td></td></tr> <tr><td>52</td><td></td><td>50</td><td></td><td></td><td>47</td><td></td><td></td><td></td><td></td><td></td><td>41</td><td></td><td></td><td>38</td><td>37</td><td>36</td><td></td><td>34</td><td>33</td></tr> <tr><td></td><td></td><td></td><td></td><td>73</td><td></td><td></td><td>32</td><td>31</td><td>30</td><td>29</td><td>28</td><td>27</td><td>25</td><td>24</td><td>23</td><td></td><td>20</td><td>19</td><td>18</td><td>17</td></tr> <tr><td></td><td></td><td></td><td></td><td></td><td>16</td><td></td><td></td><td></td><td></td><td>13</td><td>12</td><td>11</td><td>10</td><td>9</td><td></td><td></td><td></td><td></td><td>1</td></tr> </table>					68			65		63		61		59	58		56				52		50			47						41			38	37	36		34	33					73			32	31	30	29	28	27	25	24	23		20	19	18	17						16					13	12	11	10	9					1																					
				68			65		63		61		59	58		56																																																																																													
52		50			47						41			38	37	36		34	33																																																																																										
				73			32	31	30	29	28	27	25	24	23		20	19	18	17																																																																																									
					16					13	12	11	10	9					1																																																																																										
AVAILABLE	NOT APPLICABLE	34566-2113	G	0	H	ST GRAY	<table border="1"> <tr><td></td><td>79</td><td>78</td><td>77</td><td>76</td><td>75</td><td>74</td><td>73</td><td>72</td><td>71</td><td>70</td><td>69</td><td>68</td><td></td><td>66</td><td>65</td><td>64</td><td>63</td><td></td><td>61</td></tr> <tr><td>60</td><td>59</td><td>58</td><td>57</td><td>56</td><td>55</td><td></td><td>53</td><td>52</td><td></td><td>50</td><td></td><td></td><td></td><td></td><td></td><td>44</td><td>43</td><td>42</td><td>41</td></tr> <tr><td>40</td><td>39</td><td>38</td><td>37</td><td></td><td>35</td><td>34</td><td>33</td><td>32</td><td></td><td>30</td><td>29</td><td></td><td>27</td><td>26</td><td></td><td></td><td></td><td></td><td>22</td><td>21</td></tr> <tr><td>20</td><td>19</td><td>18</td><td>17</td><td>16</td><td></td><td>14</td><td>13</td><td>12</td><td>11</td><td>10</td><td>9</td><td>8</td><td></td><td>6</td><td>5</td><td></td><td></td><td>3</td><td>2</td><td></td></tr> </table>		79	78	77	76	75	74	73	72	71	70	69	68		66	65	64	63		61	60	59	58	57	56	55		53	52		50						44	43	42	41	40	39	38	37		35	34	33	32		30	29		27	26					22	21	20	19	18	17	16		14	13	12	11	10	9	8		6	5			3	2																					
	79	78	77	76	75	74	73	72	71	70	69	68		66	65	64	63		61																																																																																										
60	59	58	57	56	55		53	52		50						44	43	42	41																																																																																										
40	39	38	37		35	34	33	32		30	29		27	26					22	21																																																																																									
20	19	18	17	16		14	13	12	11	10	9	8		6	5			3	2																																																																																										
AVAILABLE	NOT APPLICABLE	34566-2123	G	0	H	ST GRAY	<table border="1"> <tr><td></td><td>79</td><td>78</td><td>77</td><td>76</td><td>75</td><td>74</td><td>73</td><td>72</td><td>71</td><td>70</td><td>69</td><td>68</td><td></td><td>66</td><td>65</td><td>64</td><td>63</td><td></td><td>61</td></tr> <tr><td>60</td><td>59</td><td>58</td><td>57</td><td>56</td><td>55</td><td></td><td>53</td><td>52</td><td></td><td>50</td><td></td><td></td><td></td><td></td><td></td><td>44</td><td>43</td><td>42</td><td>41</td></tr> <tr><td>40</td><td>39</td><td>38</td><td>37</td><td></td><td>35</td><td>34</td><td>33</td><td>32</td><td></td><td>30</td><td>29</td><td></td><td>27</td><td>26</td><td></td><td></td><td></td><td></td><td>22</td><td>21</td></tr> <tr><td>20</td><td>19</td><td>18</td><td>17</td><td>16</td><td></td><td></td><td></td><td>13</td><td>12</td><td></td><td></td><td></td><td>8</td><td>6</td><td>5</td><td></td><td></td><td>3</td><td>2</td><td></td></tr> </table>		79	78	77	76	75	74	73	72	71	70	69	68		66	65	64	63		61	60	59	58	57	56	55		53	52		50						44	43	42	41	40	39	38	37		35	34	33	32		30	29		27	26					22	21	20	19	18	17	16				13	12				8	6	5			3	2																					
	79	78	77	76	75	74	73	72	71	70	69	68		66	65	64	63		61																																																																																										
60	59	58	57	56	55		53	52		50						44	43	42	41																																																																																										
40	39	38	37		35	34	33	32		30	29		27	26					22	21																																																																																									
20	19	18	17	16				13	12				8	6	5			3	2																																																																																										
AVAILABLE	NOT APPLICABLE	34566-2133	G	0	B	ST GRAY	<table border="1"> <tr><td></td><td>71</td><td>70</td><td></td><td></td><td></td><td></td><td>65</td><td>64</td><td></td><td></td><td></td><td>60</td><td>59</td><td>58</td><td>57</td><td></td><td>55</td><td>54</td><td>53</td></tr> <tr><td></td><td>51</td><td>50</td><td>49</td><td>48</td><td>46</td><td>45</td><td></td><td>43</td><td></td><td>41</td><td>40</td><td>39</td><td></td><td>37</td><td>36</td><td>35</td><td></td><td></td><td>33</td></tr> <tr><td></td><td></td><td></td><td></td><td></td><td></td><td></td><td></td><td></td><td></td><td></td><td></td><td></td><td></td><td>24</td><td>23</td><td>22</td><td></td><td>20</td><td></td></tr> <tr><td></td><td></td><td></td><td></td><td></td><td></td><td></td><td></td><td></td><td></td><td></td><td></td><td></td><td></td><td>8</td><td>7</td><td>6</td><td>5</td><td>4</td><td>3</td><td>2</td></tr> <tr><td></td><td></td><td></td><td></td><td></td><td></td><td></td><td></td><td></td><td></td><td></td><td></td><td></td><td></td><td></td><td></td><td></td><td></td><td></td><td></td><td></td></tr> </table>		71	70					65	64				60	59	58	57		55	54	53		51	50	49	48	46	45		43		41	40	39		37	36	35			33															24	23	22		20																8	7	6	5	4	3	2																					
	71	70					65	64				60	59	58	57		55	54	53																																																																																										
	51	50	49	48	46	45		43		41	40	39		37	36	35			33																																																																																										
														24	23	22		20																																																																																											
														8	7	6	5	4	3	2																																																																																									
AVAILABLE	NOT APPLICABLE	34566-2143	G	0	B	ST GRAY	<table border="1"> <tr><td></td><td>71</td><td>70</td><td></td><td></td><td></td><td></td><td>65</td><td></td><td></td><td></td><td></td><td>60</td><td>59</td><td>58</td><td>57</td><td></td><td>55</td><td>54</td><td>53</td></tr> <tr><td></td><td>51</td><td>50</td><td>49</td><td>48</td><td>46</td><td>45</td><td></td><td>43</td><td></td><td>41</td><td>40</td><td>39</td><td></td><td>37</td><td>36</td><td>35</td><td></td><td></td><td>33</td></tr> <tr><td></td><td></td><td></td><td></td><td></td><td></td><td></td><td></td><td></td><td></td><td></td><td></td><td></td><td></td><td>24</td><td>23</td><td>22</td><td></td><td>20</td><td></td></tr> <tr><td></td><td></td><td></td><td></td><td></td><td></td><td></td><td></td><td></td><td></td><td></td><td></td><td></td><td></td><td>8</td><td>7</td><td>6</td><td>5</td><td>4</td><td></td><td></td></tr> <tr><td></td><td></td><td></td><td></td><td></td><td></td><td></td><td></td><td></td><td></td><td></td><td></td><td></td><td></td><td></td><td></td><td></td><td></td><td></td><td></td><td></td></tr> </table>		71	70					65					60	59	58	57		55	54	53		51	50	49	48	46	45		43		41	40	39		37	36	35			33															24	23	22		20																8	7	6	5	4																							
	71	70					65					60	59	58	57		55	54	53																																																																																										
	51	50	49	48	46	45		43		41	40	39		37	36	35			33																																																																																										
														24	23	22		20																																																																																											
														8	7	6	5	4																																																																																											
AVAILABLE	NOT APPLICABLE	34566-2153	G	0	A	BLACK	<table border="1"> <tr><td></td><td></td><td>70</td><td></td><td>68</td><td>67</td><td>66</td><td>65</td><td></td><td></td><td></td><td></td><td></td><td></td><td>58</td><td>57</td><td></td><td>55</td><td></td><td></td></tr> <tr><td></td><td></td><td>49</td><td></td><td>47</td><td></td><td></td><td></td><td>44</td><td>43</td><td>42</td><td>41</td><td></td><td>39</td><td></td><td>37</td><td></td><td></td><td></td><td></td></tr> <tr><td></td><td></td><td></td><td></td><td></td><td></td><td></td><td></td><td></td><td>27</td><td></td><td>25</td><td>24</td><td>23</td><td></td><td>21</td><td>20</td><td>19</td><td>18</td><td></td></tr> <tr><td></td><td></td><td></td><td></td><td></td><td></td><td></td><td></td><td></td><td></td><td></td><td></td><td></td><td></td><td>8</td><td>6</td><td>5</td><td></td><td>3</td><td>1</td></tr> </table>			70		68	67	66	65							58	57		55					49		47				44	43	42	41		39		37														27		25	24	23		21	20	19	18																8	6	5		3	1																						
		70		68	67	66	65							58	57		55																																																																																												
		49		47				44	43	42	41		39		37																																																																																														
									27		25	24	23		21	20	19	18																																																																																											
														8	6	5		3	1																																																																																										
AVAILABLE	NOT APPLICABLE	34566-2163	G	0	A	BLACK	<table border="1"> <tr><td></td><td></td><td>70</td><td></td><td>67</td><td>66</td><td></td><td></td><td></td><td></td><td>61</td><td></td><td></td><td></td><td>58</td><td></td><td>55</td><td>54</td><td></td><td></td></tr> <tr><td></td><td></td><td>49</td><td></td><td>47</td><td></td><td>45</td><td>44</td><td>43</td><td>42</td><td>41</td><td></td><td>39</td><td></td><td>37</td><td></td><td></td><td>34</td><td></td><td></td></tr> <tr><td></td><td></td><td></td><td></td><td></td><td></td><td></td><td></td><td></td><td>27</td><td></td><td>24</td><td></td><td></td><td>21</td><td>20</td><td>19</td><td>18</td><td>17</td><td></td></tr> <tr><td></td><td></td><td></td><td></td><td></td><td></td><td></td><td></td><td></td><td></td><td></td><td></td><td></td><td></td><td>6</td><td>5</td><td></td><td>3</td><td>1</td><td></td></tr> </table>			70		67	66					61				58		55	54					49		47		45	44	43	42	41		39		37			34												27		24			21	20	19	18	17																6	5		3	1																							
		70		67	66					61				58		55	54																																																																																												
		49		47		45	44	43	42	41		39		37			34																																																																																												
									27		24			21	20	19	18	17																																																																																											
														6	5		3	1																																																																																											
AVAILABLE	NOT APPLICABLE	34566-2173	G	0	A	BLACK	<table border="1"> <tr><td></td><td></td><td>70</td><td></td><td>67</td><td>66</td><td>65</td><td></td><td></td><td></td><td>61</td><td></td><td></td><td></td><td>58</td><td></td><td>55</td><td>54</td><td></td><td></td></tr> <tr><td></td><td></td><td>49</td><td></td><td>47</td><td></td><td>45</td><td>44</td><td>43</td><td>42</td><td>41</td><td></td><td>39</td><td></td><td>37</td><td></td><td></td><td>34</td><td></td><td></td></tr> <tr><td></td><td></td><td></td><td></td><td></td><td></td><td></td><td></td><td></td><td>27</td><td></td><td>25</td><td>24</td><td></td><td>21</td><td>20</td><td>19</td><td>18</td><td>17</td><td></td></tr> <tr><td></td><td></td><td></td><td></td><td></td><td></td><td></td><td></td><td></td><td></td><td></td><td></td><td></td><td></td><td>6</td><td>5</td><td></td><td>3</td><td>1</td><td></td></tr> </table>			70		67	66	65				61				58		55	54					49		47		45	44	43	42	41		39		37			34												27		25	24		21	20	19	18	17																6	5		3	1																							
		70		67	66	65				61				58		55	54																																																																																												
		49		47		45	44	43	42	41		39		37			34																																																																																												
									27		25	24		21	20	19	18	17																																																																																											
														6	5		3	1																																																																																											
AVAILABLE	NOT APPLICABLE	34566-2183	G	0	A	BLACK	<table border="1"> <tr><td></td><td></td><td>70</td><td></td><td>67</td><td>66</td><td>65</td><td></td><td></td><td></td><td></td><td></td><td></td><td></td><td>58</td><td>57</td><td></td><td>55</td><td></td><td></td></tr> <tr><td></td><td></td><td>49</td><td></td><td>47</td><td></td><td></td><td>44</td><td>43</td><td>42</td><td>41</td><td></td><td>39</td><td></td><td>37</td><td></td><td></td><td>34</td><td></td><td></td></tr> <tr><td></td><td></td><td></td><td></td><td></td><td></td><td></td><td></td><td></td><td>27</td><td></td><td>24</td><td></td><td></td><td>21</td><td>20</td><td>19</td><td>18</td><td>17</td><td></td></tr> <tr><td></td><td></td><td></td><td></td><td></td><td></td><td></td><td></td><td></td><td></td><td></td><td></td><td></td><td></td><td>6</td><td>5</td><td></td><td>3</td><td>1</td><td></td></tr> </table>			70		67	66	65								58	57		55					49		47			44	43	42	41		39		37			34												27		24			21	20	19	18	17																6	5		3	1																							
		70		67	66	65								58	57		55																																																																																												
		49		47			44	43	42	41		39		37			34																																																																																												
									27		24			21	20	19	18	17																																																																																											
														6	5		3	1																																																																																											

ENTER DESCRIPTION EEC NO: UAU2016-0232 DRAWN BY: 2015/08/14 CHKD: APPR: IKOSHY 2015/08/14 REV: G34	QUALITY SYMBOLS ∇=0 ∇=0 ∇=0	GENERAL TOLERANCES (UNLESS SPECIFIED) 4 PLACES ±---+--- 3 PLACES ±---+--- 2 PLACES ±---+--- 1 PLACE ±---+--- 0 PLACE ±---+---	DIMENSION STYLE MM ONLY	SCALE METRIC	DESIGN UNITS METRIC	THIRD ANGLE PROJECTION
	DRAWN BY: SKRAJENDRANA 2011/02/14 CHECKED BY: MYANSLAMBROU 2011/02/14 APPROVED BY:		DATE:		TITLE:	
	MATERIAL NO.: DRAFT WHERE APPLICABLE MUST REMAIN WITHIN DIMENSIONS		SEE BOM TABLE		DOCUMENT NO.: SD-34566-001	
	SHEET NO.: 26 OF 85		THIS DRAWING CONTAINS INFORMATION THAT IS PROPRIETARY TO MOLEX INCORPORATED AND SHOULD NOT BE USED WITHOUT WRITTEN PERMISSION		SHEET NO.:	

STATUS	GM PART #	MATERIAL #	PART/MATERIAL REVISION	WIRE DRESS OPTION	KEY OPTION	COLOR (TPA)	NUMBERS INDICATE CAVITIES OPEN FOR CIRCUITS																																																																																				
AVAILABLE	NOT APPLICABLE	34566-2193	G	0	A	BLACK	<table border="1"> <tr><td></td><td>70</td><td></td><td>67</td><td>66</td><td>65</td><td></td><td></td><td></td><td></td><td></td><td></td><td>58</td><td>57</td><td>55</td><td></td><td></td></tr> <tr><td></td><td></td><td>49</td><td>47</td><td></td><td></td><td>44</td><td>43</td><td>42</td><td>41</td><td></td><td>39</td><td></td><td>37</td><td></td><td>20</td><td>19</td><td>18</td><td>17</td></tr> <tr><td>73</td><td></td><td></td><td>32</td><td>30</td><td></td><td></td><td></td><td>27</td><td>25</td><td>24</td><td></td><td></td><td>21</td><td>20</td><td>19</td><td>18</td><td>17</td></tr> <tr><td></td><td></td><td></td><td></td><td>15</td><td></td><td>13</td><td></td><td></td><td></td><td>9</td><td>8</td><td></td><td>6</td><td>5</td><td></td><td>3</td><td>1</td></tr> </table>		70		67	66	65							58	57	55					49	47			44	43	42	41		39		37		20	19	18	17	73			32	30				27	25	24			21	20	19	18	17					15		13				9	8		6	5		3	1												
	70		67	66	65							58	57	55																																																																													
		49	47			44	43	42	41		39		37		20	19	18	17																																																																									
73			32	30				27	25	24			21	20	19	18	17																																																																										
				15		13				9	8		6	5		3	1																																																																										
AVAILABLE	NOT APPLICABLE	34566-2213	G	9	H	ST GRAY	<table border="1"> <tr><td></td><td>79</td><td>78</td><td>77</td><td>76</td><td>75</td><td>74</td><td>73</td><td>72</td><td>71</td><td>70</td><td>69</td><td>68</td><td></td><td>66</td><td>65</td><td>64</td><td>63</td><td>61</td></tr> <tr><td>60</td><td>59</td><td>58</td><td>57</td><td>56</td><td></td><td></td><td>53</td><td></td><td></td><td>50</td><td></td><td></td><td></td><td></td><td></td><td>44</td><td>43</td><td>41</td></tr> <tr><td>40</td><td>39</td><td>38</td><td>37</td><td></td><td>35</td><td>34</td><td>33</td><td>32</td><td></td><td>30</td><td>29</td><td></td><td>27</td><td>26</td><td></td><td>24</td><td>23</td><td>22</td><td>21</td></tr> <tr><td>20</td><td>19</td><td>18</td><td>17</td><td></td><td></td><td>14</td><td>13</td><td>12</td><td>11</td><td>10</td><td>9</td><td>8</td><td></td><td>6</td><td>5</td><td></td><td>3</td><td>2</td></tr> </table>		79	78	77	76	75	74	73	72	71	70	69	68		66	65	64	63	61	60	59	58	57	56			53			50						44	43	41	40	39	38	37		35	34	33	32		30	29		27	26		24	23	22	21	20	19	18	17			14	13	12	11	10	9	8		6	5		3	2							
	79	78	77	76	75	74	73	72	71	70	69	68		66	65	64	63	61																																																																									
60	59	58	57	56			53			50						44	43	41																																																																									
40	39	38	37		35	34	33	32		30	29		27	26		24	23	22	21																																																																								
20	19	18	17			14	13	12	11	10	9	8		6	5		3	2																																																																									
AVAILABLE	NOT APPLICABLE	34566-2223	G	0	A	BLACK	<table border="1"> <tr><td>72</td><td>71</td><td>70</td><td>69</td><td>68</td><td>67</td><td>66</td><td></td><td>64</td><td>63</td><td>62</td><td></td><td>60</td><td>59</td><td></td><td></td><td></td><td>55</td><td>54</td><td>53</td></tr> <tr><td>52</td><td></td><td>49</td><td>48</td><td>46</td><td></td><td></td><td>44</td><td>43</td><td>42</td><td></td><td>40</td><td>39</td><td></td><td></td><td></td><td></td><td>35</td><td>34</td><td>33</td></tr> <tr><td></td><td></td><td></td><td></td><td></td><td></td><td></td><td>32</td><td></td><td>29</td><td></td><td>27</td><td></td><td>24</td><td>23</td><td></td><td></td><td>19</td><td>18</td><td>17</td></tr> <tr><td>73</td><td></td><td></td><td></td><td></td><td></td><td>16</td><td></td><td>14</td><td>13</td><td>12</td><td>11</td><td></td><td>9</td><td>8</td><td>7</td><td>6</td><td>5</td><td>4</td><td>3</td><td>2</td><td>1</td></tr> </table>	72	71	70	69	68	67	66		64	63	62		60	59				55	54	53	52		49	48	46			44	43	42		40	39					35	34	33								32		29		27		24	23			19	18	17	73						16		14	13	12	11		9	8	7	6	5	4	3	2	1		
72	71	70	69	68	67	66		64	63	62		60	59				55	54	53																																																																								
52		49	48	46			44	43	42		40	39					35	34	33																																																																								
							32		29		27		24	23			19	18	17																																																																								
73						16		14	13	12	11		9	8	7	6	5	4	3	2	1																																																																						
AVAILABLE	NOT APPLICABLE	34566-2233	G	0	A	BLACK	<table border="1"> <tr><td></td><td></td><td>69</td><td></td><td></td><td></td><td></td><td></td><td>63</td><td></td><td></td><td></td><td></td><td></td><td>58</td><td></td><td>56</td><td></td><td>54</td><td></td></tr> <tr><td>52</td><td>51</td><td>49</td><td></td><td></td><td></td><td></td><td>44</td><td>43</td><td>42</td><td>41</td><td></td><td></td><td></td><td></td><td></td><td>36</td><td>35</td><td>34</td><td>33</td></tr> <tr><td></td><td></td><td></td><td>32</td><td></td><td></td><td></td><td></td><td>28</td><td>26</td><td></td><td></td><td></td><td></td><td></td><td></td><td></td><td>19</td><td>18</td><td></td></tr> <tr><td>73</td><td></td><td></td><td></td><td>16</td><td></td><td></td><td></td><td>12</td><td>10</td><td></td><td></td><td></td><td></td><td></td><td></td><td></td><td>3</td><td></td><td></td></tr> </table>			69						63						58		56		54		52	51	49					44	43	42	41						36	35	34	33				32					28	26								19	18		73				16				12	10								3						
		69						63						58		56		54																																																																									
52	51	49					44	43	42	41						36	35	34	33																																																																								
			32					28	26								19	18																																																																									
73				16				12	10								3																																																																										
AVAILABLE	NOT APPLICABLE	34566-2243	G	0	H	ST GRAY	<table border="1"> <tr><td></td><td>79</td><td>78</td><td>77</td><td>76</td><td>75</td><td>74</td><td>73</td><td>72</td><td>71</td><td>70</td><td>69</td><td>68</td><td></td><td>66</td><td>65</td><td>64</td><td>63</td><td>61</td></tr> <tr><td>60</td><td>59</td><td>58</td><td>57</td><td>56</td><td></td><td></td><td>53</td><td>52</td><td></td><td>50</td><td></td><td></td><td></td><td></td><td></td><td>44</td><td>43</td><td>41</td></tr> <tr><td>40</td><td>39</td><td>38</td><td>37</td><td></td><td>35</td><td>34</td><td>33</td><td>32</td><td></td><td>30</td><td>29</td><td></td><td>27</td><td>26</td><td></td><td>24</td><td>23</td><td>22</td><td>21</td></tr> <tr><td>20</td><td>19</td><td>18</td><td>17</td><td></td><td></td><td>14</td><td>13</td><td>12</td><td>11</td><td>10</td><td>9</td><td>8</td><td></td><td>6</td><td>5</td><td></td><td>3</td><td>2</td></tr> </table>		79	78	77	76	75	74	73	72	71	70	69	68		66	65	64	63	61	60	59	58	57	56			53	52		50						44	43	41	40	39	38	37		35	34	33	32		30	29		27	26		24	23	22	21	20	19	18	17			14	13	12	11	10	9	8		6	5		3	2							
	79	78	77	76	75	74	73	72	71	70	69	68		66	65	64	63	61																																																																									
60	59	58	57	56			53	52		50						44	43	41																																																																									
40	39	38	37		35	34	33	32		30	29		27	26		24	23	22	21																																																																								
20	19	18	17			14	13	12	11	10	9	8		6	5		3	2																																																																									
AVAILABLE	NOT APPLICABLE	34566-2253	G	0	A	BLACK	<table border="1"> <tr><td>72</td><td>71</td><td>70</td><td>69</td><td>68</td><td></td><td>66</td><td>65</td><td>64</td><td>63</td><td></td><td>61</td><td></td><td>59</td><td>58</td><td></td><td>56</td><td></td><td>54</td><td>53</td></tr> <tr><td>52</td><td></td><td>50</td><td>49</td><td>47</td><td></td><td></td><td></td><td></td><td>42</td><td>41</td><td></td><td></td><td></td><td>38</td><td>37</td><td>36</td><td></td><td>34</td><td>33</td></tr> <tr><td></td><td></td><td></td><td></td><td></td><td>32</td><td>31</td><td>30</td><td></td><td>29</td><td>28</td><td>27</td><td>26</td><td></td><td>24</td><td>23</td><td>22</td><td>21</td><td>20</td><td>19</td><td>18</td><td>17</td></tr> <tr><td>73</td><td></td><td></td><td></td><td></td><td></td><td>16</td><td></td><td></td><td>13</td><td>12</td><td>11</td><td>10</td><td>9</td><td>8</td><td></td><td></td><td></td><td></td><td></td><td></td><td>1</td></tr> </table>	72	71	70	69	68		66	65	64	63		61		59	58		56		54	53	52		50	49	47					42	41				38	37	36		34	33						32	31	30		29	28	27	26		24	23	22	21	20	19	18	17	73						16			13	12	11	10	9	8							1
72	71	70	69	68		66	65	64	63		61		59	58		56		54	53																																																																								
52		50	49	47					42	41				38	37	36		34	33																																																																								
					32	31	30		29	28	27	26		24	23	22	21	20	19	18	17																																																																						
73						16			13	12	11	10	9	8							1																																																																						
AVAILABLE	NOT APPLICABLE	34566-2263	G	0	A	BLACK	<table border="1"> <tr><td></td><td></td><td>69</td><td></td><td></td><td></td><td></td><td></td><td>63</td><td></td><td></td><td></td><td></td><td></td><td>58</td><td></td><td>56</td><td>55</td><td>54</td><td>53</td></tr> <tr><td>52</td><td>51</td><td>50</td><td>49</td><td></td><td></td><td></td><td>44</td><td>43</td><td>42</td><td>41</td><td></td><td></td><td></td><td></td><td></td><td>36</td><td>35</td><td>34</td><td>33</td></tr> <tr><td></td><td></td><td></td><td></td><td>32</td><td></td><td></td><td></td><td>28</td><td>26</td><td></td><td></td><td></td><td></td><td></td><td></td><td></td><td>19</td><td>18</td><td></td></tr> <tr><td>73</td><td></td><td></td><td></td><td></td><td>16</td><td></td><td>14</td><td></td><td>12</td><td>10</td><td></td><td></td><td></td><td></td><td></td><td></td><td>3</td><td></td><td></td></tr> </table>			69						63						58		56	55	54	53	52	51	50	49				44	43	42	41						36	35	34	33					32				28	26								19	18		73					16		14		12	10							3						
		69						63						58		56	55	54	53																																																																								
52	51	50	49				44	43	42	41						36	35	34	33																																																																								
				32				28	26								19	18																																																																									
73					16		14		12	10							3																																																																										
AVAILABLE	NOT APPLICABLE	34566-2273	G	0	A	BLACK	<table border="1"> <tr><td></td><td></td><td>69</td><td></td><td></td><td></td><td></td><td></td><td>63</td><td>62</td><td>61</td><td></td><td></td><td></td><td>58</td><td>57</td><td>56</td><td>55</td><td>54</td><td>53</td></tr> <tr><td>52</td><td>51</td><td>50</td><td>49</td><td></td><td></td><td></td><td>44</td><td>43</td><td>42</td><td>41</td><td></td><td></td><td></td><td></td><td>37</td><td>36</td><td>35</td><td>34</td><td>33</td></tr> <tr><td></td><td></td><td></td><td></td><td>32</td><td></td><td></td><td></td><td>29</td><td>28</td><td>27</td><td>26</td><td></td><td></td><td></td><td></td><td></td><td>19</td><td>18</td><td></td></tr> <tr><td>73</td><td></td><td></td><td></td><td></td><td>16</td><td></td><td>14</td><td>13</td><td>12</td><td>11</td><td>10</td><td></td><td></td><td></td><td></td><td></td><td>3</td><td></td><td></td></tr> </table>			69						63	62	61				58	57	56	55	54	53	52	51	50	49				44	43	42	41					37	36	35	34	33					32				29	28	27	26						19	18		73					16		14	13	12	11	10						3						
		69						63	62	61				58	57	56	55	54	53																																																																								
52	51	50	49				44	43	42	41					37	36	35	34	33																																																																								
				32				29	28	27	26						19	18																																																																									
73					16		14	13	12	11	10						3																																																																										
AVAILABLE	NOT APPLICABLE	34566-2283	G	0	B	ST. GRAY	<table border="1"> <tr><td></td><td></td><td></td><td>49</td><td>68</td><td>67</td><td>66</td><td>65</td><td>64</td><td>63</td><td></td><td></td><td></td><td></td><td></td><td></td><td></td><td></td><td>55</td><td></td></tr> <tr><td></td><td></td><td></td><td></td><td>48</td><td>46</td><td></td><td>45</td><td>44</td><td>43</td><td></td><td></td><td></td><td></td><td></td><td></td><td></td><td></td><td></td><td></td></tr> <tr><td></td><td></td><td></td><td></td><td></td><td>32</td><td>30</td><td></td><td>29</td><td>28</td><td>27</td><td></td><td></td><td></td><td></td><td></td><td></td><td></td><td></td><td>17</td></tr> <tr><td>73</td><td></td><td></td><td></td><td></td><td></td><td>16</td><td></td><td></td><td></td><td></td><td>10</td><td></td><td></td><td></td><td></td><td></td><td></td><td></td><td></td></tr> </table>				49	68	67	66	65	64	63									55						48	46		45	44	43																32	30		29	28	27									17	73						16					10												
			49	68	67	66	65	64	63									55																																																																									
				48	46		45	44	43																																																																																		
					32	30		29	28	27									17																																																																								
73						16					10																																																																																

ENTER DESCRIPTION ELEC NO: VALU2016-0232 DRAWN BY: SKRAJENDRANA CHKD: MVANSLAMBROU APPR: WOSHY REV: G34	QUALITY SYMBOLS ∇=0 ∇=0 ∇=0	GENERAL TOLERANCES (UNLESS SPECIFIED) mm INCH 4 PLACES ± --- ± --- 3 PLACES ± --- ± --- 2 PLACES ± --- ± --- 1 PLACE ± --- ± --- 0 PLACE ± --- ± ---	DIMENSION STYLE MM ONLY	SCALE METRIC	DESIGN UNITS METRIC	THIRD ANGLE PROJECTION 	
	DRAWN BY: SKRAJENDRANA DATE: 2011/02/14	CHECKED BY: MVANSLAMBROU DATE: 2011/02/14	APPROVED BY:	MATERIAL NO.	DOCUMENT NO.	TITLE MX123 66/73/80CKT HRNS CONN ASSY	SHEET NO. 27 OF 85
	ANGULAR ± ---° DRAFT WHERE APPLICABLE MUST REMAIN WITHIN DIMENSIONS	SEE BOM TABLE	THIS DRAWING CONTAINS INFORMATION THAT IS PROPRIETARY TO MOLEX INCORPORATED AND SHOULD NOT BE USED WITHOUT WRITTEN PERMISSION	SD-34566-001	SD-34566-001	molex	SD-34566-001
	THIS DRAWING CONTAINS INFORMATION THAT IS PROPRIETARY TO MOLEX INCORPORATED AND SHOULD NOT BE USED WITHOUT WRITTEN PERMISSION						

STATUS	GM PART #	MATERIAL #	PART/MATERIAL REVISION	WIRE DRESS OPTION	KEY OPTION	COLOR (TPA)	NUMBERS INDICATE CAVITIES OPEN FOR CIRCUITS																																																																
AVAILABLE	NOT APPLICABLE	34566-2293	G	0	C	BLUE	<table border="1"> <tr><td>72</td><td>70</td><td>68</td><td>66</td><td>63</td><td>59</td><td>57</td><td>53</td></tr> <tr><td>52</td><td>51</td><td>48</td><td>47</td><td>46</td><td>44</td><td>42</td><td>40</td><td>39</td><td>34</td><td>33</td></tr> <tr><td colspan="2">73</td><td>30</td><td>26</td><td>25</td><td>22</td><td>21</td><td></td><td></td><td></td><td></td></tr> <tr><td colspan="2"></td><td>15</td><td>14</td><td>10</td><td>9</td><td>6</td><td></td><td></td><td></td><td></td></tr> </table>	72	70	68	66	63	59	57	53	52	51	48	47	46	44	42	40	39	34	33	73		30	26	25	22	21							15	14	10	9	6																											
72	70	68	66	63	59	57	53																																																																
52	51	48	47	46	44	42	40	39	34	33																																																													
73		30	26	25	22	21																																																																	
		15	14	10	9	6																																																																	
AVAILABLE	NOT APPLICABLE	34566-2313	G	0	C	BLUE	<table border="1"> <tr><td>72</td><td>70</td><td>66</td><td>63</td><td>59</td><td>57</td><td>53</td></tr> <tr><td>52</td><td>51</td><td>46</td><td>44</td><td>42</td><td>40</td><td>39</td><td>34</td><td>33</td></tr> <tr><td colspan="2">73</td><td>30</td><td>26</td><td>25</td><td>22</td><td>21</td><td></td><td></td><td></td></tr> <tr><td colspan="2"></td><td>15</td><td>14</td><td>10</td><td>9</td><td>6</td><td></td><td></td><td></td></tr> </table>	72	70	66	63	59	57	53	52	51	46	44	42	40	39	34	33	73		30	26	25	22	21						15	14	10	9	6																															
72	70	66	63	59	57	53																																																																	
52	51	46	44	42	40	39	34	33																																																															
73		30	26	25	22	21																																																																	
		15	14	10	9	6																																																																	
AVAILABLE	NOT APPLICABLE	34566-2323	G	0	C	BLUE	<table border="1"> <tr><td>72</td><td>70</td><td>68</td><td>66</td><td>63</td><td>59</td><td>57</td><td>53</td></tr> <tr><td>52</td><td>51</td><td>48</td><td>47</td><td>46</td><td>44</td><td>42</td><td>40</td><td>39</td><td>34</td><td>33</td></tr> <tr><td colspan="2">73</td><td>30</td><td>26</td><td>25</td><td>22</td><td>21</td><td>20</td><td></td><td></td><td></td></tr> <tr><td colspan="2"></td><td>15</td><td>14</td><td>10</td><td>9</td><td>6</td><td>5</td><td>4</td><td></td><td></td></tr> </table>	72	70	68	66	63	59	57	53	52	51	48	47	46	44	42	40	39	34	33	73		30	26	25	22	21	20						15	14	10	9	6	5	4																									
72	70	68	66	63	59	57	53																																																																
52	51	48	47	46	44	42	40	39	34	33																																																													
73		30	26	25	22	21	20																																																																
		15	14	10	9	6	5	4																																																															
AVAILABLE	NOT APPLICABLE	34566-2333	G	0	A	BLACK	<table border="1"> <tr><td>71</td><td>69</td><td>68</td><td>65</td><td>64</td><td>63</td><td>61</td><td>59</td><td>57</td><td>56</td><td>34</td><td>33</td></tr> <tr><td>52</td><td>50</td><td>49</td><td>47</td><td>46</td><td>44</td><td>42</td><td>41</td><td>39</td><td>38</td><td>37</td><td>36</td><td>34</td><td>33</td></tr> <tr><td colspan="2">73</td><td>32</td><td>31</td><td>30</td><td>29</td><td>28</td><td>27</td><td>24</td><td>23</td><td>22</td><td>20</td><td>19</td><td>18</td><td>1</td></tr> <tr><td colspan="2"></td><td>16</td><td>13</td><td>12</td><td>11</td><td>10</td><td>9</td><td></td><td></td><td></td><td></td><td></td><td></td><td></td></tr> </table>	71	69	68	65	64	63	61	59	57	56	34	33	52	50	49	47	46	44	42	41	39	38	37	36	34	33	73		32	31	30	29	28	27	24	23	22	20	19	18	1			16	13	12	11	10	9															
71	69	68	65	64	63	61	59	57	56	34	33																																																												
52	50	49	47	46	44	42	41	39	38	37	36	34	33																																																										
73		32	31	30	29	28	27	24	23	22	20	19	18	1																																																									
		16	13	12	11	10	9																																																																
AVAILABLE	NOT APPLICABLE	34566-2343	G	0	A	BLACK	<table border="1"> <tr><td>72</td><td>70</td><td>68</td><td>67</td><td>66</td><td>65</td><td>58</td><td>57</td><td>55</td><td></td><td></td><td></td></tr> <tr><td></td><td>49</td><td>47</td><td>44</td><td>43</td><td>42</td><td>41</td><td>39</td><td>37</td><td>35</td><td></td><td></td></tr> <tr><td colspan="2">73</td><td>32</td><td>30</td><td>27</td><td>25</td><td>24</td><td>21</td><td>20</td><td>19</td><td>18</td><td>17</td></tr> <tr><td colspan="2"></td><td>15</td><td>14</td><td>13</td><td>9</td><td>8</td><td>6</td><td>5</td><td>3</td><td>1</td><td></td></tr> </table>	72	70	68	67	66	65	58	57	55					49	47	44	43	42	41	39	37	35			73		32	30	27	25	24	21	20	19	18	17			15	14	13	9	8	6	5	3	1																	
72	70	68	67	66	65	58	57	55																																																															
	49	47	44	43	42	41	39	37	35																																																														
73		32	30	27	25	24	21	20	19	18	17																																																												
		15	14	13	9	8	6	5	3	1																																																													
AVAILABLE	NOT APPLICABLE	34566-2353	G	0	A	BLACK	<table border="1"> <tr><td>72</td><td>70</td><td>67</td><td>66</td><td>65</td><td>58</td><td>57</td><td>55</td><td></td><td></td><td></td></tr> <tr><td></td><td>49</td><td>47</td><td>44</td><td>43</td><td>42</td><td>41</td><td>39</td><td>37</td><td>35</td><td></td><td></td></tr> <tr><td colspan="2">73</td><td>32</td><td>30</td><td>27</td><td>25</td><td>24</td><td>21</td><td>20</td><td>19</td><td>18</td><td>17</td></tr> <tr><td colspan="2"></td><td>15</td><td>14</td><td>13</td><td>9</td><td>8</td><td>6</td><td>5</td><td>3</td><td>1</td><td></td></tr> </table>	72	70	67	66	65	58	57	55					49	47	44	43	42	41	39	37	35			73		32	30	27	25	24	21	20	19	18	17			15	14	13	9	8	6	5	3	1																		
72	70	67	66	65	58	57	55																																																																
	49	47	44	43	42	41	39	37	35																																																														
73		32	30	27	25	24	21	20	19	18	17																																																												
		15	14	13	9	8	6	5	3	1																																																													
AVAILABLE	NOT APPLICABLE	34566-2363	G	0	C	BLUE	<table border="1"> <tr><td>72</td><td>70</td><td>67</td><td>66</td><td>63</td><td>62</td><td>59</td><td>57</td><td>53</td></tr> <tr><td>52</td><td>51</td><td>46</td><td>44</td><td>42</td><td>40</td><td>39</td><td>38</td><td>34</td><td>33</td></tr> <tr><td colspan="2">73</td><td>32</td><td>30</td><td>27</td><td>26</td><td>25</td><td>22</td><td>21</td><td>20</td><td></td></tr> <tr><td colspan="2"></td><td>15</td><td>14</td><td>10</td><td>9</td><td>6</td><td>5</td><td>4</td><td></td><td></td></tr> </table>	72	70	67	66	63	62	59	57	53	52	51	46	44	42	40	39	38	34	33	73		32	30	27	26	25	22	21	20				15	14	10	9	6	5	4																									
72	70	67	66	63	62	59	57	53																																																															
52	51	46	44	42	40	39	38	34	33																																																														
73		32	30	27	26	25	22	21	20																																																														
		15	14	10	9	6	5	4																																																															
AVAILABLE	NOT APPLICABLE	34566-2373	G	0	B	ST GRAY	<table border="1"> <tr><td>68</td><td>67</td><td>66</td><td>65</td><td>64</td><td>61</td><td>60</td><td>59</td><td>58</td><td>57</td><td>55</td><td>54</td><td>53</td></tr> <tr><td>51</td><td>50</td><td>49</td><td>48</td><td>47</td><td>46</td><td>45</td><td>43</td><td>42</td><td>41</td><td>40</td><td>39</td><td>38</td><td>37</td><td>35</td><td>34</td><td>33</td></tr> <tr><td colspan="2">73</td><td>32</td><td>31</td><td>30</td><td>26</td><td>24</td><td>23</td><td>22</td><td>21</td><td>20</td><td></td><td></td><td></td><td></td><td></td><td></td></tr> <tr><td colspan="2"></td><td>16</td><td>15</td><td>14</td><td>13</td><td>10</td><td>9</td><td>8</td><td>7</td><td>6</td><td>5</td><td>4</td><td>3</td><td>2</td><td></td><td></td></tr> </table>	68	67	66	65	64	61	60	59	58	57	55	54	53	51	50	49	48	47	46	45	43	42	41	40	39	38	37	35	34	33	73		32	31	30	26	24	23	22	21	20									16	15	14	13	10	9	8	7	6	5	4	3	2		
68	67	66	65	64	61	60	59	58	57	55	54	53																																																											
51	50	49	48	47	46	45	43	42	41	40	39	38	37	35	34	33																																																							
73		32	31	30	26	24	23	22	21	20																																																													
		16	15	14	13	10	9	8	7	6	5	4	3	2																																																									
AVAILABLE	NOT APPLICABLE	34566-2383	G	0	B	ST GRAY	<table border="1"> <tr><td>65</td><td>59</td><td>57</td><td>55</td><td>53</td></tr> <tr><td>50</td><td>49</td><td>48</td><td>46</td><td>39</td><td>37</td><td>35</td><td>33</td></tr> <tr><td colspan="2">73</td><td>29</td><td>24</td><td>23</td><td>21</td><td></td><td></td></tr> <tr><td colspan="2"></td><td>15</td><td>7</td><td>6</td><td>5</td><td>4</td><td>3</td><td></td><td></td><td></td><td></td></tr> </table>	65	59	57	55	53	50	49	48	46	39	37	35	33	73		29	24	23	21					15	7	6	5	4	3																																			
65	59	57	55	53																																																																			
50	49	48	46	39	37	35	33																																																																
73		29	24	23	21																																																																		
		15	7	6	5	4	3																																																																

ENTER DESCRIPTION EC NO: UAU2016-0232 DRAWN BY: 2015/08/14 CHKD: APPR: VIKASHY REV: G34	QUALITY SYMBOLS ∇=0 ∇=0 ∇=0	GENERAL TOLERANCES (UNLESS SPECIFIED): mm INCH 4 PLACES ± --- ± --- 3 PLACES ± --- ± --- 2 PLACES ± --- ± --- 1 PLACE ± --- ± --- 0 PLACE ± --- ± --- ANGULAR ± --- ° DRAFT WHERE APPLICABLE MUST REMAIN WITHIN DIMENSIONS	DIMENSION STYLE MM ONLY DRAWN BY: SKRAJENDRANA 2011/02/14 CHECKED BY: MVANSLAMBROU 2011/02/14 APPROVED BY:	SCALE: DESIGN UNITS: METRIC THIRD ANGLE PROJECTION
	TITLE: MX123 66/73/80CKT HRNS CONN ASSY molex			
	MATERIAL NO.: SD-34566-001		DOCUMENT NO.: SD-34566-001	
	SHEET NO.: 28 OF 85 THIS DRAWING CONTAINS INFORMATION THAT IS PROPRIETARY TO MOLEX INCORPORATED AND SHOULD NOT BE USED WITHOUT WRITTEN PERMISSION			

STATUS	GM PART #	MATERIAL #	PART/MATERIAL REVISION	WIRE DRESS OPTION	KEY OPTION	COLOR (TPA)	NUMBERS INDICATE CAVITIES OPEN FOR CIRCUITS																																																																																																																
AVAILABLE	NOT APPLICABLE	34566-2483	G	0	A	BLACK	<table border="1"> <tr><td></td><td></td><td></td><td>69</td><td></td><td></td><td></td><td></td><td></td><td></td><td>63</td><td>62</td><td>61</td><td></td><td></td><td>58</td><td>57</td><td>56</td><td>55</td><td>54</td><td>53</td></tr> <tr><td>52</td><td>51</td><td>49</td><td></td><td></td><td></td><td></td><td></td><td></td><td>44</td><td>43</td><td>42</td><td>41</td><td></td><td></td><td></td><td>37</td><td>36</td><td>35</td><td>34</td><td>33</td></tr> <tr><td colspan="20">73</td></tr> <tr><td></td><td></td><td></td><td>32</td><td></td><td></td><td></td><td></td><td></td><td>29</td><td>28</td><td>27</td><td>26</td><td></td><td></td><td>23</td><td></td><td></td><td></td><td>19</td><td>18</td></tr> <tr><td></td><td></td><td></td><td>16</td><td></td><td></td><td></td><td></td><td></td><td>13</td><td>12</td><td>11</td><td>10</td><td></td><td></td><td>8</td><td></td><td></td><td></td><td>3</td><td></td></tr> </table>				69							63	62	61			58	57	56	55	54	53	52	51	49							44	43	42	41				37	36	35	34	33	73																							32						29	28	27	26			23				19	18				16						13	12	11	10			8				3									
			69							63	62	61			58	57	56	55	54	53																																																																																																			
52	51	49							44	43	42	41				37	36	35	34	33																																																																																																			
73																																																																																																																							
			32						29	28	27	26			23				19	18																																																																																																			
			16						13	12	11	10			8				3																																																																																																				
AVAILABLE	NOT APPLICABLE	34566-2493	G	0	B	ST GRY	<table border="1"> <tr><td>72</td><td>71</td><td>70</td><td></td><td></td><td>68</td><td>67</td><td>66</td><td></td><td></td><td></td><td></td><td>62</td><td>61</td><td>60</td><td>59</td><td>58</td><td>57</td><td>56</td><td>55</td><td>54</td><td>53</td></tr> <tr><td>52</td><td>51</td><td>50</td><td></td><td></td><td>48</td><td>47</td><td>46</td><td></td><td></td><td></td><td></td><td>42</td><td>41</td><td>40</td><td>39</td><td>38</td><td>37</td><td>36</td><td>35</td><td>34</td><td>33</td></tr> <tr><td colspan="20">73</td></tr> <tr><td></td><td></td><td></td><td>32</td><td>31</td><td>30</td><td>29</td><td>28</td><td>27</td><td>26</td><td>25</td><td>24</td><td></td><td></td><td></td><td></td><td></td><td></td><td></td><td></td><td>17</td></tr> <tr><td></td><td></td><td></td><td>16</td><td>15</td><td>14</td><td>13</td><td></td><td></td><td></td><td></td><td></td><td>10</td><td></td><td></td><td>8</td><td></td><td></td><td></td><td></td><td>2</td><td>1</td></tr> </table>	72	71	70			68	67	66					62	61	60	59	58	57	56	55	54	53	52	51	50			48	47	46					42	41	40	39	38	37	36	35	34	33	73																							32	31	30	29	28	27	26	25	24									17				16	15	14	13						10			8					2	1					
72	71	70			68	67	66					62	61	60	59	58	57	56	55	54	53																																																																																																		
52	51	50			48	47	46					42	41	40	39	38	37	36	35	34	33																																																																																																		
73																																																																																																																							
			32	31	30	29	28	27	26	25	24									17																																																																																																			
			16	15	14	13						10			8					2	1																																																																																																		
AVAILABLE	NOT APPLICABLE	34566-2513	G	0	C	BLUE	<table border="1"> <tr><td>72</td><td>71</td><td>70</td><td></td><td></td><td>68</td><td>67</td><td>66</td><td></td><td></td><td>63</td><td>62</td><td></td><td></td><td>59</td><td></td><td></td><td>57</td><td></td><td></td><td></td><td>53</td></tr> <tr><td>52</td><td>51</td><td></td><td></td><td></td><td>48</td><td>47</td><td>46</td><td></td><td></td><td>44</td><td></td><td></td><td></td><td>42</td><td>40</td><td>39</td><td></td><td></td><td></td><td></td><td>34</td><td>33</td></tr> <tr><td colspan="20">73</td></tr> <tr><td></td><td></td><td></td><td>32</td><td></td><td>30</td><td></td><td></td><td></td><td></td><td>27</td><td>26</td><td>25</td><td></td><td></td><td></td><td></td><td>22</td><td>21</td><td>20</td><td></td><td></td></tr> <tr><td></td><td></td><td></td><td></td><td></td><td>15</td><td>14</td><td></td><td></td><td></td><td></td><td>10</td><td>9</td><td></td><td></td><td></td><td></td><td>6</td><td>5</td><td>4</td><td></td><td></td></tr> </table>	72	71	70			68	67	66			63	62			59			57				53	52	51				48	47	46			44				42	40	39					34	33	73																							32		30					27	26	25					22	21	20								15	14					10	9					6	5	4					
72	71	70			68	67	66			63	62			59			57				53																																																																																																		
52	51				48	47	46			44				42	40	39					34	33																																																																																																	
73																																																																																																																							
			32		30					27	26	25					22	21	20																																																																																																				
					15	14					10	9					6	5	4																																																																																																				
AVAILABLE	NOT APPLICABLE	34566-2523	G	0	A	BLACK	<table border="1"> <tr><td>72</td><td>71</td><td>70</td><td>69</td><td>68</td><td>67</td><td>66</td><td></td><td></td><td>65</td><td>64</td><td>63</td><td>62</td><td></td><td>60</td><td>59</td><td></td><td></td><td></td><td>55</td><td>54</td><td>53</td></tr> <tr><td>52</td><td></td><td></td><td>49</td><td>48</td><td></td><td></td><td></td><td></td><td>45</td><td>44</td><td>43</td><td>42</td><td></td><td>41</td><td>40</td><td>39</td><td></td><td></td><td></td><td>35</td><td>34</td><td>33</td></tr> <tr><td colspan="20">73</td></tr> <tr><td></td><td></td><td></td><td>32</td><td></td><td></td><td></td><td></td><td></td><td>29</td><td>28</td><td>27</td><td>26</td><td>25</td><td>24</td><td>23</td><td></td><td></td><td></td><td></td><td>19</td><td>18</td><td>17</td></tr> <tr><td></td><td></td><td></td><td>16</td><td></td><td></td><td></td><td></td><td></td><td>13</td><td>12</td><td>11</td><td></td><td></td><td>9</td><td>8</td><td>7</td><td>6</td><td>5</td><td>4</td><td>3</td><td>2</td><td>1</td></tr> </table>	72	71	70	69	68	67	66			65	64	63	62		60	59				55	54	53	52			49	48					45	44	43	42		41	40	39				35	34	33	73																							32						29	28	27	26	25	24	23					19	18	17				16						13	12	11			9	8	7	6	5	4	3	2	1	
72	71	70	69	68	67	66			65	64	63	62		60	59				55	54	53																																																																																																		
52			49	48					45	44	43	42		41	40	39				35	34	33																																																																																																	
73																																																																																																																							
			32						29	28	27	26	25	24	23					19	18	17																																																																																																	
			16						13	12	11			9	8	7	6	5	4	3	2	1																																																																																																	
AVAILABLE	NOT APPLICABLE	34566-2533	G	0	B	ST GRY	<table border="1"> <tr><td></td><td></td><td></td><td></td><td></td><td>67</td><td>66</td><td>65</td><td></td><td></td><td>63</td><td></td><td></td><td></td><td>59</td><td>58</td><td>57</td><td>56</td><td>55</td><td></td><td></td><td>53</td></tr> <tr><td></td><td></td><td>50</td><td>49</td><td>48</td><td></td><td>46</td><td>45</td><td>43</td><td></td><td></td><td></td><td></td><td></td><td>39</td><td>38</td><td>37</td><td>36</td><td>35</td><td>34</td><td>33</td><td></td></tr> <tr><td colspan="20">73</td></tr> <tr><td></td><td></td><td></td><td></td><td></td><td></td><td></td><td>29</td><td>27</td><td></td><td></td><td></td><td></td><td></td><td>23</td><td>22</td><td>21</td><td></td><td></td><td></td><td>18</td><td></td></tr> <tr><td></td><td></td><td></td><td></td><td></td><td></td><td></td><td>15</td><td>14</td><td>13</td><td></td><td></td><td></td><td></td><td>8</td><td>7</td><td>6</td><td>5</td><td>4</td><td>3</td><td></td><td></td></tr> </table>						67	66	65			63				59	58	57	56	55			53			50	49	48		46	45	43						39	38	37	36	35	34	33		73																											29	27						23	22	21				18									15	14	13					8	7	6	5	4	3						
					67	66	65			63				59	58	57	56	55			53																																																																																																		
		50	49	48		46	45	43						39	38	37	36	35	34	33																																																																																																			
73																																																																																																																							
							29	27						23	22	21				18																																																																																																			
							15	14	13					8	7	6	5	4	3																																																																																																				
AVAILABLE	NOT APPLICABLE	34566-2543	G	0	C	BLUE	<table border="1"> <tr><td>72</td><td>71</td><td>70</td><td></td><td></td><td></td><td>66</td><td></td><td></td><td></td><td>63</td><td></td><td></td><td></td><td>59</td><td></td><td></td><td>57</td><td></td><td></td><td></td><td>53</td></tr> <tr><td>52</td><td>51</td><td></td><td></td><td></td><td></td><td>46</td><td></td><td></td><td>44</td><td></td><td></td><td>42</td><td></td><td>40</td><td>39</td><td></td><td></td><td></td><td></td><td></td><td>34</td><td>33</td></tr> <tr><td colspan="20">73</td></tr> <tr><td></td><td></td><td></td><td>32</td><td></td><td></td><td>30</td><td></td><td></td><td></td><td>27</td><td>26</td><td>25</td><td></td><td></td><td></td><td></td><td>22</td><td>21</td><td></td><td></td><td></td></tr> <tr><td></td><td></td><td></td><td></td><td></td><td></td><td>15</td><td>14</td><td></td><td></td><td></td><td>10</td><td>9</td><td></td><td></td><td></td><td></td><td>6</td><td>5</td><td></td><td></td><td></td></tr> </table>	72	71	70				66				63				59			57				53	52	51					46			44			42		40	39						34	33	73																							32			30				27	26	25					22	21										15	14				10	9					6	5						
72	71	70				66				63				59			57				53																																																																																																		
52	51					46			44			42		40	39						34	33																																																																																																	
73																																																																																																																							
			32			30				27	26	25					22	21																																																																																																					
						15	14				10	9					6	5																																																																																																					
AVAILABLE	NOT APPLICABLE	34566-2553	G	9	B	ST GRY	<table border="1"> <tr><td>72</td><td>71</td><td>70</td><td></td><td></td><td>68</td><td>67</td><td>66</td><td></td><td></td><td></td><td></td><td>62</td><td>61</td><td>60</td><td>59</td><td>58</td><td>57</td><td>56</td><td>55</td><td>54</td><td>53</td></tr> <tr><td>52</td><td>51</td><td>50</td><td></td><td></td><td>48</td><td>47</td><td>46</td><td></td><td></td><td></td><td></td><td>42</td><td>41</td><td>40</td><td>39</td><td>38</td><td>37</td><td>36</td><td>35</td><td>34</td><td>33</td></tr> <tr><td colspan="20">73</td></tr> <tr><td></td><td></td><td></td><td>32</td><td>31</td><td>30</td><td>29</td><td>28</td><td>27</td><td>26</td><td>25</td><td>24</td><td>23</td><td></td><td></td><td></td><td></td><td></td><td></td><td></td><td></td><td></td></tr> <tr><td></td><td></td><td></td><td>16</td><td>15</td><td>14</td><td>13</td><td></td><td></td><td></td><td></td><td></td><td>10</td><td>9</td><td>8</td><td></td><td></td><td></td><td></td><td></td><td></td><td></td></tr> </table>	72	71	70			68	67	66					62	61	60	59	58	57	56	55	54	53	52	51	50			48	47	46					42	41	40	39	38	37	36	35	34	33	73																							32	31	30	29	28	27	26	25	24	23													16	15	14	13						10	9	8											
72	71	70			68	67	66					62	61	60	59	58	57	56	55	54	53																																																																																																		
52	51	50			48	47	46					42	41	40	39	38	37	36	35	34	33																																																																																																		
73																																																																																																																							
			32	31	30	29	28	27	26	25	24	23																																																																																																											
			16	15	14	13						10	9	8																																																																																																									
AVAILABLE	NOT APPLICABLE	34566-2563	G	9	A	BLACK	<table border="1"> <tr><td></td><td></td><td></td><td>69</td><td></td><td></td><td></td><td></td><td></td><td></td><td></td><td></td><td>63</td><td>62</td><td>61</td><td></td><td></td><td>58</td><td>57</td><td>56</td><td>55</td><td>54</td><td>53</td></tr> <tr><td>52</td><td>51</td><td>50</td><td>49</td><td></td><td></td><td></td><td></td><td></td><td></td><td></td><td></td><td>44</td><td>43</td><td>42</td><td>41</td><td></td><td></td><td>37</td><td>36</td><td>35</td><td>34</td><td>33</td></tr> <tr><td colspan="20">73</td></tr> <tr><td></td><td></td><td></td><td>32</td><td></td><td></td><td></td><td></td><td></td><td></td><td></td><td></td><td>29</td><td>28</td><td>27</td><td>26</td><td></td><td></td><td></td><td></td><td></td><td>19</td><td>18</td></tr> <tr><td></td><td></td><td></td><td>16</td><td></td><td></td><td></td><td></td><td></td><td></td><td></td><td></td><td>13</td><td>12</td><td>11</td><td>10</td><td></td><td></td><td></td><td></td><td></td><td>3</td><td></td></tr> </table>				69									63	62	61			58	57	56	55	54	53	52	51	50	49									44	43	42	41			37	36	35	34	33	73																							32									29	28	27	26						19	18				16									13	12	11	10						3	
			69									63	62	61			58	57	56	55	54	53																																																																																																	
52	51	50	49									44	43	42	41			37	36	35	34	33																																																																																																	
73																																																																																																																							
			32									29	28	27	26						19	18																																																																																																	
			16									13	12	11	10						3																																																																																																		
AVAILABLE	NOT APPLICABLE	34566-2573	G	9	C	BLUE	<table border="1"> <tr><td>72</td><td>71</td><td>70</td><td></td><td></td><td>67</td><td>66</td><td></td><td></td><td></td><td>63</td><td>62</td><td></td><td></td><td>59</td><td></td><td></td><td>57</td><td></td><td></td><td></td><td>53</td></tr> <tr><td>52</td><td>51</td><td></td><td></td><td></td><td>46</td><td></td><td></td><td></td><td>44</td><td></td><td></td><td>42</td><td></td><td>40</td><td>39</td><td></td><td></td><td></td><td></td><td></td><td>34</td><td>33</td></tr> <tr><td colspan="20">73</td></tr> <tr><td></td><td></td><td></td><td></td><td></td><td></td><td>30</td><td></td><td></td><td></td><td></td><td></td><td>26</td><td>25</td><td></td><td></td><td></td><td>22</td><td>21</td><td>20</td><td></td><td></td></tr> <tr><td></td><td></td><td></td><td></td><td></td><td></td><td>15</td><td>14</td><td></td><td></td><td></td><td></td><td>10</td><td>9</td><td></td><td></td><td></td><td>6</td><td>5</td><td>4</td><td></td><td></td></tr> </table>	72	71	70			67	66				63	62			59			57				53	52	51				46				44			42		40	39						34	33	73																										30						26	25				22	21	20									15	14					10	9				6	5	4					
72	71	70			67	66				63	62			59			57				53																																																																																																		
52	51				46				44			42		40	39						34	33																																																																																																	
73																																																																																																																							
						30						26	25				22	21	20																																																																																																				
						15	14					10	9				6	5	4																																																																																																				

ENTER DESCRIPTION ELC NO: UAU2016-0232 DRAWN BY: 2015/08/14 CHKD: 2015/08/14 APPR: IKOSHY REV: G34	QUALITY SYMBOLS ∇=0 ∇=0 ∇=0	GENERAL TOLERANCES (UNLESS SPECIFIED) <table border="1"> <tr><th></th><th>mm</th><th>INCH</th></tr> <tr><td>4 PLACES</td><td>±---</td><td>±---</td></tr> <tr><td>3 PLACES</td><td>±---</td><td>±---</td></tr> <tr><td>2 PLACES</td><td>±---</td><td>±---</td></tr> <tr><td>1 PLACE</td><td>±---</td><td>±---</td></tr> <tr><td>0 PLACE</td><td>±---</td><td>±---</td></tr> </table>		mm	INCH	4 PLACES	±---	±---	3 PLACES	±---	±---	2 PLACES	±---	±---	1 PLACE	±---	±---	0 PLACE	±---	±---	DIMENSION STYLE MM ONLY	SCALE MM ONLY	DESIGN UNITS METRIC	THIRD ANGLE PROJECTION
		mm	INCH																					
	4 PLACES	±---	±---																					
	3 PLACES	±---	±---																					
2 PLACES	±---	±---																						
1 PLACE	±---	±---																						
0 PLACE	±---	±---																						
DRAFT WHERE APPLICABLE MUST REMAIN WITHIN DIMENSIONS	GENERAL TOLERANCES (UNLESS SPECIFIED) ANGULAR ±---°	DRAWN BY SKRA JENDRANA 2011/02/14	DATE 2011/02/14	CHECKED BY MYANSLAMBROU 2011/02/14	DATE 2011/02/14	TITLE MX123 66/73/80CKT HRNS CONN ASSY																		
SEE BOM TABLE	MATERIAL NO. SD-34566-001	APPROVED BY DATE	DOCUMENT NO. SD-34566-001	SHEET NO. 30 OF 85	INCORPORATED AND SHOULD NOT BE USED WITHOUT WRITTEN PERMISSION	MOLEX																		
THIS DRAWING CONTAINS INFORMATION THAT IS PROPRIETARY TO MOLEX																								

STATUS	GM PART #	MATERIAL #	PART/MATERIAL REVISION	WIRE DRESS OPTION	KEY OPTION	COLOR (TPA)	NUMBERS INDICATE CAVITIES OPEN FOR CIRCUITS																																																																										
AVAILABLE	NOT APPLICABLE	34566-2583	G	0	A	BLACK	<table border="1"> <tr><td></td><td></td><td>69</td><td></td><td></td><td></td><td>63</td><td></td><td></td><td>58</td><td>56</td><td>55</td><td>54</td><td>53</td></tr> <tr><td>52</td><td>51</td><td>50</td><td>49</td><td></td><td></td><td>44</td><td>43</td><td>42</td><td>41</td><td>39</td><td></td><td>36</td><td>35</td><td>34</td><td>33</td></tr> <tr><td></td><td></td><td>73</td><td></td><td>32</td><td></td><td>28</td><td>26</td><td></td><td></td><td></td><td></td><td>19</td><td>18</td><td></td><td></td></tr> <tr><td></td><td></td><td></td><td></td><td>16</td><td></td><td>14</td><td>12</td><td>10</td><td></td><td></td><td></td><td>3</td><td></td><td></td><td></td></tr> </table>			69				63			58	56	55	54	53	52	51	50	49			44	43	42	41	39		36	35	34	33			73		32		28	26					19	18							16		14	12	10				3															
		69				63			58	56	55	54	53																																																																				
52	51	50	49			44	43	42	41	39		36	35	34	33																																																																		
		73		32		28	26					19	18																																																																				
				16		14	12	10				3																																																																					
AVAILABLE	NOT APPLICABLE	34566-2593	G	0	C	BLUE	<table border="1"> <tr><td>72</td><td>70</td><td></td><td></td><td>66</td><td></td><td>63</td><td>62</td><td></td><td>59</td><td>57</td><td></td><td></td><td></td><td>53</td><td></td></tr> <tr><td>52</td><td>51</td><td></td><td></td><td>46</td><td>44</td><td>42</td><td>40</td><td>39</td><td></td><td></td><td></td><td></td><td></td><td>34</td><td>33</td></tr> <tr><td></td><td></td><td>73</td><td></td><td>32</td><td>30</td><td></td><td>27</td><td>26</td><td>25</td><td></td><td>22</td><td>21</td><td></td><td></td><td></td></tr> <tr><td></td><td></td><td></td><td></td><td>15</td><td>14</td><td></td><td></td><td>10</td><td>9</td><td></td><td>6</td><td></td><td></td><td></td><td></td></tr> </table>	72	70			66		63	62		59	57				53		52	51			46	44	42	40	39						34	33			73		32	30		27	26	25		22	21								15	14			10	9		6														
72	70			66		63	62		59	57				53																																																																			
52	51			46	44	42	40	39						34	33																																																																		
		73		32	30		27	26	25		22	21																																																																					
				15	14			10	9		6																																																																						
AVAILABLE	NOT APPLICABLE	34566-2613	G	9	C	BLUE	<table border="1"> <tr><td>72</td><td>70</td><td></td><td>67</td><td>66</td><td></td><td>63</td><td>62</td><td></td><td>59</td><td>57</td><td></td><td></td><td></td><td>53</td><td></td></tr> <tr><td>52</td><td>51</td><td></td><td></td><td>46</td><td>44</td><td>42</td><td>40</td><td>39</td><td></td><td></td><td></td><td></td><td></td><td>34</td><td>33</td></tr> <tr><td></td><td></td><td>73</td><td></td><td></td><td>30</td><td></td><td>27</td><td>26</td><td>25</td><td></td><td>22</td><td>21</td><td>20</td><td></td><td></td></tr> <tr><td></td><td></td><td></td><td></td><td>15</td><td>14</td><td></td><td></td><td>10</td><td>9</td><td></td><td>6</td><td>5</td><td>4</td><td></td><td></td></tr> </table>	72	70		67	66		63	62		59	57				53		52	51			46	44	42	40	39						34	33			73			30		27	26	25		22	21	20							15	14			10	9		6	5	4												
72	70		67	66		63	62		59	57				53																																																																			
52	51			46	44	42	40	39						34	33																																																																		
		73			30		27	26	25		22	21	20																																																																				
				15	14			10	9		6	5	4																																																																				
AVAILABLE	NOT APPLICABLE	34566-2623	G	0	A	BLACK	<table border="1"> <tr><td>71</td><td>69</td><td>68</td><td>67</td><td></td><td>65</td><td>64</td><td>63</td><td></td><td>61</td><td>59</td><td></td><td>57</td><td>56</td><td></td><td></td></tr> <tr><td></td><td>50</td><td>49</td><td></td><td>47</td><td></td><td></td><td></td><td></td><td>41</td><td></td><td></td><td>38</td><td>37</td><td>36</td><td>34</td><td>33</td></tr> <tr><td></td><td></td><td>73</td><td></td><td>32</td><td>31</td><td>30</td><td>29</td><td>28</td><td>27</td><td></td><td>24</td><td>23</td><td></td><td>20</td><td>19</td><td>18</td></tr> <tr><td></td><td></td><td></td><td></td><td>16</td><td></td><td></td><td>13</td><td>12</td><td>11</td><td>10</td><td>9</td><td>7</td><td></td><td>4</td><td></td><td></td></tr> </table>	71	69	68	67		65	64	63		61	59		57	56				50	49		47					41			38	37	36	34	33			73		32	31	30	29	28	27		24	23		20	19	18					16			13	12	11	10	9	7		4									
71	69	68	67		65	64	63		61	59		57	56																																																																				
	50	49		47					41			38	37	36	34	33																																																																	
		73		32	31	30	29	28	27		24	23		20	19	18																																																																	
				16			13	12	11	10	9	7		4																																																																			
AVAILABLE	NOT APPLICABLE	34566-2633	G	0	A	BLACK	<table border="1"> <tr><td>71</td><td>69</td><td>68</td><td>67</td><td></td><td>65</td><td>64</td><td></td><td></td><td>61</td><td>59</td><td></td><td>57</td><td>56</td><td></td><td></td></tr> <tr><td></td><td>50</td><td>49</td><td></td><td>47</td><td></td><td></td><td></td><td></td><td>41</td><td></td><td></td><td>38</td><td>37</td><td>36</td><td></td><td>33</td></tr> <tr><td></td><td></td><td>73</td><td></td><td>32</td><td>31</td><td>30</td><td>29</td><td>28</td><td>27</td><td></td><td>24</td><td>23</td><td></td><td>20</td><td>19</td><td>18</td></tr> <tr><td></td><td></td><td></td><td></td><td>16</td><td></td><td></td><td></td><td></td><td>11</td><td>10</td><td>9</td><td>7</td><td></td><td>4</td><td></td><td></td></tr> </table>	71	69	68	67		65	64			61	59		57	56				50	49		47					41			38	37	36		33			73		32	31	30	29	28	27		24	23		20	19	18					16					11	10	9	7		4									
71	69	68	67		65	64			61	59		57	56																																																																				
	50	49		47					41			38	37	36		33																																																																	
		73		32	31	30	29	28	27		24	23		20	19	18																																																																	
				16					11	10	9	7		4																																																																			
AVAILABLE	NOT APPLICABLE	34566-2643	G	0	A	BLACK	<table border="1"> <tr><td>71</td><td>69</td><td>68</td><td>67</td><td></td><td>65</td><td>64</td><td>63</td><td></td><td>61</td><td>59</td><td></td><td>57</td><td>56</td><td></td><td></td></tr> <tr><td></td><td>50</td><td>49</td><td></td><td>47</td><td></td><td></td><td></td><td></td><td>41</td><td>39</td><td>38</td><td>37</td><td>36</td><td></td><td>34</td><td>33</td></tr> <tr><td></td><td></td><td>73</td><td></td><td>32</td><td>31</td><td>30</td><td>29</td><td>28</td><td>27</td><td></td><td>24</td><td>23</td><td>22</td><td>20</td><td>19</td><td>18</td></tr> <tr><td></td><td></td><td></td><td></td><td>16</td><td></td><td></td><td></td><td></td><td>13</td><td>12</td><td>11</td><td>10</td><td>9</td><td>7</td><td></td><td>4</td></tr> </table>	71	69	68	67		65	64	63		61	59		57	56				50	49		47					41	39	38	37	36		34	33			73		32	31	30	29	28	27		24	23	22	20	19	18					16					13	12	11	10	9	7		4							
71	69	68	67		65	64	63		61	59		57	56																																																																				
	50	49		47					41	39	38	37	36		34	33																																																																	
		73		32	31	30	29	28	27		24	23	22	20	19	18																																																																	
				16					13	12	11	10	9	7		4																																																																	
AVAILABLE	NOT APPLICABLE	34566-2653	G	0	A	BLACK	<table border="1"> <tr><td>71</td><td>69</td><td>68</td><td>67</td><td></td><td>65</td><td>64</td><td></td><td></td><td>61</td><td>59</td><td></td><td>57</td><td>56</td><td></td><td></td></tr> <tr><td></td><td>50</td><td>49</td><td></td><td>47</td><td></td><td></td><td></td><td></td><td>41</td><td>39</td><td>38</td><td>37</td><td>36</td><td></td><td>34</td><td>33</td></tr> <tr><td></td><td></td><td>73</td><td></td><td>32</td><td>31</td><td>30</td><td>29</td><td>28</td><td>27</td><td></td><td>24</td><td>23</td><td>22</td><td>20</td><td>19</td><td>18</td></tr> <tr><td></td><td></td><td></td><td></td><td>16</td><td></td><td></td><td></td><td></td><td>11</td><td>10</td><td>9</td><td>7</td><td></td><td>4</td><td></td><td></td></tr> </table>	71	69	68	67		65	64			61	59		57	56				50	49		47					41	39	38	37	36		34	33			73		32	31	30	29	28	27		24	23	22	20	19	18					16					11	10	9	7		4									
71	69	68	67		65	64			61	59		57	56																																																																				
	50	49		47					41	39	38	37	36		34	33																																																																	
		73		32	31	30	29	28	27		24	23	22	20	19	18																																																																	
				16					11	10	9	7		4																																																																			
AVAILABLE	NOT APPLICABLE	34566-2663	G	0	H	ST GRAY	<table border="1"> <tr><td>79</td><td>78</td><td>77</td><td>76</td><td>75</td><td>74</td><td>73</td><td>72</td><td>71</td><td>70</td><td>69</td><td>68</td><td></td><td>66</td><td>65</td><td>64</td><td>63</td><td>61</td></tr> <tr><td>60</td><td>59</td><td>58</td><td>57</td><td>56</td><td></td><td></td><td>53</td><td>52</td><td>50</td><td></td><td></td><td></td><td></td><td></td><td>44</td><td>43</td><td>41</td></tr> <tr><td>40</td><td>39</td><td>38</td><td>37</td><td></td><td>35</td><td>34</td><td></td><td>32</td><td>30</td><td>29</td><td></td><td>27</td><td>26</td><td></td><td></td><td></td><td>22</td><td>21</td></tr> <tr><td>20</td><td>19</td><td>18</td><td>17</td><td></td><td></td><td></td><td>13</td><td>12</td><td></td><td></td><td></td><td>8</td><td>6</td><td>5</td><td></td><td>3</td><td>2</td><td></td></tr> </table>	79	78	77	76	75	74	73	72	71	70	69	68		66	65	64	63	61	60	59	58	57	56			53	52	50						44	43	41	40	39	38	37		35	34		32	30	29		27	26				22	21	20	19	18	17				13	12				8	6	5		3	2	
79	78	77	76	75	74	73	72	71	70	69	68		66	65	64	63	61																																																																
60	59	58	57	56			53	52	50						44	43	41																																																																
40	39	38	37		35	34		32	30	29		27	26				22	21																																																															
20	19	18	17				13	12				8	6	5		3	2																																																																
AVAILABLE	NOT APPLICABLE	34566-2673	G	0	H	ST GRAY	<table border="1"> <tr><td>79</td><td>78</td><td>77</td><td>76</td><td>75</td><td>74</td><td>73</td><td>72</td><td>71</td><td>70</td><td>69</td><td>68</td><td></td><td>66</td><td>65</td><td>64</td><td>63</td><td>61</td></tr> <tr><td>60</td><td>59</td><td>58</td><td>57</td><td>56</td><td></td><td></td><td>53</td><td>52</td><td>50</td><td></td><td></td><td></td><td></td><td></td><td>44</td><td>43</td><td>41</td></tr> <tr><td>40</td><td>39</td><td>38</td><td>37</td><td></td><td>35</td><td>34</td><td></td><td>32</td><td>30</td><td>29</td><td></td><td>27</td><td>26</td><td></td><td></td><td></td><td>22</td><td>21</td></tr> <tr><td>20</td><td>19</td><td>18</td><td>17</td><td>16</td><td></td><td></td><td>13</td><td>12</td><td></td><td></td><td></td><td>8</td><td>6</td><td>5</td><td></td><td>3</td><td>2</td><td></td></tr> </table>	79	78	77	76	75	74	73	72	71	70	69	68		66	65	64	63	61	60	59	58	57	56			53	52	50						44	43	41	40	39	38	37		35	34		32	30	29		27	26				22	21	20	19	18	17	16			13	12				8	6	5		3	2	
79	78	77	76	75	74	73	72	71	70	69	68		66	65	64	63	61																																																																
60	59	58	57	56			53	52	50						44	43	41																																																																
40	39	38	37		35	34		32	30	29		27	26				22	21																																																															
20	19	18	17	16			13	12				8	6	5		3	2																																																																

ENTER DESCRIPTION EC NO: UAU2016-0232 DRAWN BY: 2015/08/14 CHKD: 2015/08/14 APPR: IKOSHY REV: G34	QUALITY SYMBOLS ∇=0 ∇=0 ∇=0	GENERAL TOLERANCES (UNLESS SPECIFIED) mm INCH 4 PLACES ±--- ±--- 3 PLACES ±--- ±--- 2 PLACES ±--- ±--- 1 PLACE ±--- ±--- 0 PLACE ±--- ±--- ANGULAR ±---° DRAFT WHERE APPLICABLE MUST REMAIN WITHIN DIMENSIONS	DIMENSION STYLE MM ONLY DRAWN BY: SKRAJENDRANA 2011/02/14 CHECKED BY: MYANSLAMBROU 2011/02/14 APPROVED BY:	SCALE: METRIC DESIGN UNITS: METRIC THIRD ANGLE PROJECTION	TITLE: MX123 66/73/80CKT HRNS CONN ASSY molex	MATERIAL NO.: SD-34566-001	DOCUMENT NO.: SHEET NO.: 31 OF 85
	THIS DRAWING CONTAINS INFORMATION THAT IS PROPRIETARY TO MOLEX INCORPORATED AND SHOULD NOT BE USED WITHOUT WRITTEN PERMISSION						
	SEE BOM TABLE						
	SIZE D						

STATUS	GM PART #	MATERIAL #	PART/MATERIAL REVISION	WIRE DRESS OPTION	KEY OPTION	COLOR (TPA)	NUMBERS INDICATE CAVITIES OPEN FOR CIRCUITS																																																																																		
AVAILABLE	NOT APPLICABLE	34566-2793	G	9	A	BLACK	<table border="1"> <tr><td></td><td></td><td></td><td></td><td>67</td><td>66</td><td></td><td></td><td></td><td></td><td></td><td></td><td></td><td></td><td></td><td></td><td></td><td></td><td></td><td></td><td></td></tr> <tr><td></td><td></td><td></td><td></td><td>48</td><td>47</td><td></td><td></td><td></td><td></td><td>41</td><td></td><td></td><td></td><td></td><td></td><td></td><td></td><td></td><td></td><td></td></tr> <tr><td></td><td>73</td><td></td><td></td><td>32</td><td>31</td><td>30</td><td>29</td><td></td><td>27</td><td></td><td>25</td><td></td><td></td><td>22</td><td>21</td><td></td><td>19</td><td>18</td><td>17</td></tr> <tr><td></td><td></td><td></td><td></td><td>16</td><td>15</td><td>14</td><td>13</td><td></td><td>11</td><td>10</td><td>9</td><td>8</td><td>7</td><td>6</td><td>5</td><td>4</td><td>3</td><td></td><td>1</td></tr> </table>					67	66																				48	47					41												73			32	31	30	29		27		25			22	21		19	18	17					16	15	14	13		11	10	9	8	7	6	5	4	3		1
				67	66																																																																																				
				48	47					41																																																																															
	73			32	31	30	29		27		25			22	21		19	18	17																																																																						
				16	15	14	13		11	10	9	8	7	6	5	4	3		1																																																																						
AVAILABLE	NOT APPLICABLE	34566-2813	G	9	B	ST GRAY	<table border="1"> <tr><td>72</td><td>71</td><td>70</td><td>69</td><td>68</td><td>67</td><td>66</td><td>65</td><td>64</td><td></td><td>62</td><td>61</td><td>60</td><td>59</td><td>58</td><td>57</td><td>56</td><td>55</td><td>54</td><td></td></tr> <tr><td>52</td><td>51</td><td>50</td><td>49</td><td>48</td><td>46</td><td>44</td><td></td><td></td><td></td><td></td><td>40</td><td></td><td></td><td></td><td>37</td><td>36</td><td></td><td></td><td></td></tr> <tr><td></td><td></td><td></td><td></td><td>32</td><td>31</td><td>30</td><td>29</td><td>28</td><td>27</td><td></td><td>25</td><td>24</td><td></td><td></td><td>21</td><td>20</td><td></td><td>18</td><td></td></tr> <tr><td></td><td></td><td></td><td></td><td>16</td><td>14</td><td>13</td><td>12</td><td>11</td><td>10</td><td>9</td><td></td><td>7</td><td>6</td><td></td><td>4</td><td>3</td><td>2</td><td></td><td></td></tr> </table>	72	71	70	69	68	67	66	65	64		62	61	60	59	58	57	56	55	54		52	51	50	49	48	46	44					40				37	36								32	31	30	29	28	27		25	24			21	20		18						16	14	13	12	11	10	9		7	6		4	3	2				
72	71	70	69	68	67	66	65	64		62	61	60	59	58	57	56	55	54																																																																							
52	51	50	49	48	46	44					40				37	36																																																																									
				32	31	30	29	28	27		25	24			21	20		18																																																																							
				16	14	13	12	11	10	9		7	6		4	3	2																																																																								
AVAILABLE	NOT APPLICABLE	34566-2823	G	0	A	BLACK	<table border="1"> <tr><td></td><td></td><td></td><td></td><td>67</td><td>66</td><td></td><td></td><td></td><td></td><td></td><td></td><td></td><td></td><td></td><td></td><td></td><td></td><td></td><td></td><td></td></tr> <tr><td></td><td></td><td></td><td></td><td>47</td><td></td><td></td><td></td><td></td><td></td><td>41</td><td></td><td></td><td></td><td></td><td></td><td></td><td></td><td></td><td></td><td></td></tr> <tr><td></td><td>73</td><td></td><td></td><td>32</td><td>31</td><td>30</td><td>29</td><td></td><td>27</td><td></td><td>25</td><td></td><td></td><td>22</td><td>21</td><td></td><td>19</td><td>18</td><td>17</td></tr> <tr><td></td><td></td><td></td><td></td><td>16</td><td>15</td><td>14</td><td>13</td><td></td><td></td><td>10</td><td>9</td><td>8</td><td>7</td><td>6</td><td>5</td><td>4</td><td>3</td><td></td><td></td></tr> </table>					67	66																				47						41												73			32	31	30	29		27		25			22	21		19	18	17					16	15	14	13			10	9	8	7	6	5	4	3		
				67	66																																																																																				
				47						41																																																																															
	73			32	31	30	29		27		25			22	21		19	18	17																																																																						
				16	15	14	13			10	9	8	7	6	5	4	3																																																																								
AVAILABLE	NOT APPLICABLE	34566-2833	G	0	B	ST GRAY	<table border="1"> <tr><td>72</td><td>71</td><td>70</td><td>69</td><td>68</td><td>67</td><td>66</td><td>65</td><td></td><td></td><td>61</td><td>60</td><td></td><td></td><td>57</td><td>56</td><td>55</td><td>54</td><td></td><td></td></tr> <tr><td>52</td><td>51</td><td>50</td><td>49</td><td>48</td><td>46</td><td>44</td><td></td><td></td><td></td><td></td><td>40</td><td></td><td></td><td></td><td>37</td><td>36</td><td></td><td></td><td></td></tr> <tr><td></td><td></td><td></td><td></td><td>32</td><td>31</td><td>30</td><td>29</td><td>28</td><td>27</td><td></td><td>24</td><td></td><td></td><td>21</td><td>20</td><td></td><td>19</td><td>18</td><td>17</td></tr> <tr><td></td><td></td><td></td><td></td><td>16</td><td>14</td><td>13</td><td>12</td><td>11</td><td>10</td><td>9</td><td></td><td>7</td><td>6</td><td></td><td>4</td><td>3</td><td>2</td><td></td><td></td></tr> </table>	72	71	70	69	68	67	66	65			61	60			57	56	55	54			52	51	50	49	48	46	44					40				37	36								32	31	30	29	28	27		24			21	20		19	18	17					16	14	13	12	11	10	9		7	6		4	3	2				
72	71	70	69	68	67	66	65			61	60			57	56	55	54																																																																								
52	51	50	49	48	46	44					40				37	36																																																																									
				32	31	30	29	28	27		24			21	20		19	18	17																																																																						
				16	14	13	12	11	10	9		7	6		4	3	2																																																																								
AVAILABLE	NOT APPLICABLE	34566-2843	G	0	A	BLACK	<table border="1"> <tr><td></td><td></td><td></td><td></td><td>67</td><td>66</td><td></td><td></td><td></td><td></td><td></td><td></td><td></td><td></td><td></td><td></td><td></td><td></td><td></td><td></td><td></td></tr> <tr><td></td><td></td><td></td><td></td><td>47</td><td></td><td></td><td></td><td></td><td></td><td>41</td><td></td><td></td><td></td><td></td><td></td><td></td><td></td><td></td><td></td><td></td></tr> <tr><td></td><td>73</td><td></td><td></td><td>32</td><td>31</td><td>30</td><td>29</td><td></td><td>27</td><td></td><td>25</td><td></td><td></td><td>22</td><td>21</td><td></td><td>19</td><td>18</td><td>17</td></tr> <tr><td></td><td></td><td></td><td></td><td>16</td><td>15</td><td>14</td><td>13</td><td></td><td></td><td>10</td><td>9</td><td>8</td><td>7</td><td>6</td><td>5</td><td>4</td><td>3</td><td></td><td>1</td></tr> </table>					67	66																				47						41												73			32	31	30	29		27		25			22	21		19	18	17					16	15	14	13			10	9	8	7	6	5	4	3		1
				67	66																																																																																				
				47						41																																																																															
	73			32	31	30	29		27		25			22	21		19	18	17																																																																						
				16	15	14	13			10	9	8	7	6	5	4	3		1																																																																						
AVAILABLE	NOT APPLICABLE	34566-2853	G	0	B	ST GRAY	<table border="1"> <tr><td>72</td><td>71</td><td>70</td><td>69</td><td>68</td><td>67</td><td>66</td><td>65</td><td>64</td><td>63</td><td>61</td><td>60</td><td></td><td></td><td>57</td><td>56</td><td>55</td><td>54</td><td></td><td></td></tr> <tr><td>52</td><td>51</td><td>50</td><td>49</td><td>48</td><td>46</td><td>44</td><td></td><td></td><td></td><td></td><td>40</td><td></td><td></td><td></td><td>37</td><td>36</td><td></td><td></td><td></td></tr> <tr><td></td><td></td><td></td><td></td><td>32</td><td>31</td><td>30</td><td>29</td><td>28</td><td>27</td><td></td><td>24</td><td></td><td></td><td>21</td><td>20</td><td>19</td><td>18</td><td></td><td></td></tr> <tr><td></td><td></td><td></td><td></td><td>16</td><td>14</td><td>13</td><td>12</td><td>11</td><td>10</td><td>9</td><td></td><td>7</td><td>6</td><td></td><td>4</td><td>3</td><td>2</td><td></td><td></td></tr> </table>	72	71	70	69	68	67	66	65	64	63	61	60			57	56	55	54			52	51	50	49	48	46	44					40				37	36								32	31	30	29	28	27		24			21	20	19	18							16	14	13	12	11	10	9		7	6		4	3	2				
72	71	70	69	68	67	66	65	64	63	61	60			57	56	55	54																																																																								
52	51	50	49	48	46	44					40				37	36																																																																									
				32	31	30	29	28	27		24			21	20	19	18																																																																								
				16	14	13	12	11	10	9		7	6		4	3	2																																																																								
AVAILABLE	NOT APPLICABLE	34566-2863	G	0	A	BLACK	<table border="1"> <tr><td>72</td><td>71</td><td>70</td><td>69</td><td>68</td><td>67</td><td>66</td><td></td><td>64</td><td>63</td><td>62</td><td>60</td><td>59</td><td></td><td></td><td></td><td>55</td><td>54</td><td>53</td><td></td></tr> <tr><td>52</td><td></td><td></td><td>49</td><td>48</td><td>46</td><td>44</td><td>43</td><td>42</td><td></td><td></td><td>40</td><td>39</td><td></td><td></td><td></td><td>35</td><td>34</td><td>33</td><td></td></tr> <tr><td></td><td></td><td></td><td></td><td>32</td><td></td><td></td><td>29</td><td>28</td><td>27</td><td></td><td>24</td><td>23</td><td></td><td></td><td></td><td>19</td><td>18</td><td>17</td><td></td></tr> <tr><td></td><td></td><td></td><td></td><td>16</td><td>14</td><td>13</td><td>12</td><td>11</td><td></td><td>9</td><td>8</td><td>7</td><td>6</td><td>5</td><td>4</td><td>3</td><td>2</td><td>1</td><td></td></tr> </table>	72	71	70	69	68	67	66		64	63	62	60	59				55	54	53		52			49	48	46	44	43	42			40	39				35	34	33						32			29	28	27		24	23				19	18	17						16	14	13	12	11		9	8	7	6	5	4	3	2	1			
72	71	70	69	68	67	66		64	63	62	60	59				55	54	53																																																																							
52			49	48	46	44	43	42			40	39				35	34	33																																																																							
				32			29	28	27		24	23				19	18	17																																																																							
				16	14	13	12	11		9	8	7	6	5	4	3	2	1																																																																							
AVAILABLE	NOT APPLICABLE	34566-2873	G	0	B	ST GRAY	<table border="1"> <tr><td>72</td><td>71</td><td>70</td><td>69</td><td>68</td><td>67</td><td>66</td><td></td><td></td><td></td><td></td><td></td><td>59</td><td>58</td><td>57</td><td>56</td><td>55</td><td>53</td><td></td><td></td></tr> <tr><td>52</td><td>51</td><td>50</td><td>49</td><td>48</td><td>47</td><td></td><td></td><td></td><td></td><td></td><td></td><td>39</td><td>38</td><td>37</td><td>36</td><td>35</td><td>33</td><td></td><td></td></tr> <tr><td></td><td></td><td></td><td></td><td></td><td></td><td></td><td></td><td></td><td></td><td></td><td></td><td>23</td><td>22</td><td>21</td><td></td><td></td><td></td><td></td><td></td></tr> <tr><td></td><td></td><td></td><td></td><td></td><td>15</td><td></td><td></td><td>11</td><td>10</td><td>8</td><td></td><td>6</td><td>5</td><td>4</td><td>3</td><td></td><td></td><td></td><td></td></tr> </table>	72	71	70	69	68	67	66						59	58	57	56	55	53			52	51	50	49	48	47							39	38	37	36	35	33															23	22	21											15			11	10	8		6	5	4	3						
72	71	70	69	68	67	66						59	58	57	56	55	53																																																																								
52	51	50	49	48	47							39	38	37	36	35	33																																																																								
												23	22	21																																																																											
					15			11	10	8		6	5	4	3																																																																										
AVAILABLE	NOT APPLICABLE	34566-2883	G	0	A	BLACK	<table border="1"> <tr><td></td><td>70</td><td>69</td><td></td><td></td><td></td><td></td><td></td><td>63</td><td>62</td><td>61</td><td></td><td></td><td>58</td><td>57</td><td>56</td><td>55</td><td>54</td><td>53</td><td></td></tr> <tr><td>52</td><td>51</td><td>49</td><td></td><td></td><td></td><td></td><td></td><td>44</td><td>43</td><td>42</td><td>41</td><td></td><td></td><td></td><td>37</td><td>36</td><td>34</td><td></td><td></td></tr> <tr><td></td><td></td><td></td><td></td><td></td><td></td><td></td><td></td><td>29</td><td>28</td><td>27</td><td>26</td><td></td><td></td><td></td><td></td><td>19</td><td>18</td><td></td><td></td></tr> <tr><td></td><td></td><td></td><td></td><td></td><td></td><td></td><td></td><td>13</td><td>12</td><td>11</td><td>10</td><td></td><td></td><td></td><td></td><td>3</td><td></td><td></td><td></td></tr> </table>		70	69						63	62	61			58	57	56	55	54	53		52	51	49						44	43	42	41				37	36	34											29	28	27	26					19	18											13	12	11	10					3					
	70	69						63	62	61			58	57	56	55	54	53																																																																							
52	51	49						44	43	42	41				37	36	34																																																																								
								29	28	27	26					19	18																																																																								
								13	12	11	10					3																																																																									

ENTER DESCRIPTION EEC NO: UAU2016-0232 DRAWN BY: CHKO G34 2015/08/14 2015/08/14 APPR: IKOSHY	QUALITY SYMBOLS ∇=0 ∇=0 ∇=0	GENERAL TOLERANCES (UNLESS SPECIFIED) mm INCH 4 PLACES ±--- ±--- 3 PLACES ±--- ±--- 2 PLACES ±--- ±--- 1 PLACE ±--- ±--- 0 PLACE ±--- ±---	DIMENSION STYLE MM ONLY	SCALE DESIGN UNITS METRIC	THIRD ANGLE PROJECTION
	ANGULAR ±--- DRAFT WHERE APPLICABLE MUST REMAIN WITHIN DIMENSIONS		DRAWN BY: SKRA JENDRANA 2011/02/14 CHECKED BY: MVANSLAMBROU 2011/02/14 APPROVED BY: DATE	TITLE MX123 66/73/80CKT HRNS CONN ASSY	
	MATERIAL NO. SEE BOM TABLE		DOCUMENT NO. SD-34566-001		SHEET NO. 33 OF 85
	THIS DRAWING CONTAINS INFORMATION THAT IS PROPRIETARY TO MOLEX INCORPORATED AND SHOULD NOT BE USED WITHOUT WRITTEN PERMISSION				

STATUS	GM PART #	MATERIAL #	PART/MATERIAL REVISION	WIRE DRESS OPTION	KEY OPTION	COLOR (TPA)	NUMBERS INDICATE CAVITIES OPEN FOR CIRCUITS																																																																	
AVAILABLE	NOT APPLICABLE	34566-2893	G	0	A	BLACK	<table border="1"> <tr><td>72</td><td></td><td>69</td><td>67</td><td>65</td><td>63</td><td></td><td>60</td><td></td><td>57</td><td>56</td><td></td><td>53</td></tr> <tr><td></td><td></td><td>49</td><td>47</td><td>46</td><td>44</td><td>43</td><td></td><td>40</td><td></td><td>37</td><td>36</td><td>35</td><td>33</td></tr> <tr><td></td><td>73</td><td></td><td>31</td><td>30</td><td>29</td><td>28</td><td></td><td>24</td><td></td><td>21</td><td>20</td><td></td><td>17</td></tr> <tr><td></td><td></td><td></td><td>16</td><td>15</td><td>14</td><td>13</td><td></td><td>11</td><td>10</td><td></td><td>5</td><td>4</td><td>3</td><td>2</td><td>1</td></tr> </table>	72		69	67	65	63		60		57	56		53			49	47	46	44	43		40		37	36	35	33		73		31	30	29	28		24		21	20		17				16	15	14	13		11	10		5	4	3	2	1								
72		69	67	65	63		60		57	56		53																																																												
		49	47	46	44	43		40		37	36	35	33																																																											
	73		31	30	29	28		24		21	20		17																																																											
			16	15	14	13		11	10		5	4	3	2	1																																																									
AVAILABLE	NOT APPLICABLE	34566-2913	G	0	B	ST GRAY	<table border="1"> <tr><td></td><td></td><td>68</td><td>67</td><td></td><td>64</td><td></td><td></td><td></td><td>58</td><td></td><td></td><td></td><td></td><td></td><td></td></tr> <tr><td></td><td></td><td></td><td></td><td>46</td><td>45</td><td></td><td></td><td></td><td>38</td><td></td><td></td><td></td><td></td><td></td><td></td></tr> <tr><td></td><td>73</td><td></td><td>32</td><td>30</td><td>29</td><td>28</td><td>27</td><td></td><td></td><td>22</td><td></td><td></td><td></td><td></td><td>17</td></tr> <tr><td></td><td></td><td></td><td></td><td>15</td><td>14</td><td>13</td><td></td><td>10</td><td></td><td></td><td></td><td></td><td></td><td></td><td>1</td></tr> </table>			68	67		64				58											46	45				38								73		32	30	29	28	27			22					17					15	14	13		10							1	
		68	67		64				58																																																															
				46	45				38																																																															
	73		32	30	29	28	27			22					17																																																									
				15	14	13		10							1																																																									
AVAILABLE	NOT APPLICABLE	34566-2923	G	0	B	ST GRAY	<table border="1"> <tr><td></td><td></td><td>68</td><td>67</td><td></td><td>64</td><td></td><td></td><td></td><td></td><td></td><td></td><td></td><td></td><td></td><td></td></tr> <tr><td></td><td></td><td></td><td></td><td>46</td><td>45</td><td></td><td></td><td></td><td></td><td></td><td></td><td></td><td></td><td></td><td></td></tr> <tr><td></td><td>73</td><td></td><td>32</td><td>30</td><td>29</td><td>28</td><td>27</td><td></td><td></td><td></td><td></td><td></td><td></td><td></td><td>17</td></tr> <tr><td></td><td></td><td></td><td></td><td>15</td><td>14</td><td>13</td><td></td><td>10</td><td></td><td></td><td></td><td></td><td></td><td></td><td></td></tr> </table>			68	67		64															46	45												73		32	30	29	28	27								17					15	14	13		10								
		68	67		64																																																																			
				46	45																																																																			
	73		32	30	29	28	27								17																																																									
				15	14	13		10																																																																
AVAILABLE	NOT APPLICABLE	34566-2933	G	0	A	BLACK	<table border="1"> <tr><td>72</td><td></td><td>69</td><td>67</td><td>65</td><td>63</td><td></td><td>60</td><td></td><td>57</td><td>56</td><td></td><td>53</td></tr> <tr><td></td><td></td><td>49</td><td>47</td><td>46</td><td>44</td><td>43</td><td></td><td>40</td><td></td><td>37</td><td>36</td><td>35</td><td>33</td></tr> <tr><td></td><td>73</td><td></td><td>31</td><td>30</td><td>29</td><td>28</td><td></td><td>24</td><td></td><td>21</td><td>20</td><td></td><td>17</td></tr> <tr><td></td><td></td><td></td><td>16</td><td>15</td><td>14</td><td>13</td><td></td><td>11</td><td>10</td><td></td><td>5</td><td>4</td><td>3</td><td>2</td><td>1</td></tr> </table>	72		69	67	65	63		60		57	56		53			49	47	46	44	43		40		37	36	35	33		73		31	30	29	28		24		21	20		17				16	15	14	13		11	10		5	4	3	2	1								
72		69	67	65	63		60		57	56		53																																																												
		49	47	46	44	43		40		37	36	35	33																																																											
	73		31	30	29	28		24		21	20		17																																																											
			16	15	14	13		11	10		5	4	3	2	1																																																									
AVAILABLE	NOT APPLICABLE	34566-2943	G	0	B	ST GRAY	<table border="1"> <tr><td></td><td></td><td>68</td><td>67</td><td></td><td>64</td><td>63</td><td></td><td></td><td>59</td><td>57</td><td></td><td></td><td></td><td></td><td></td></tr> <tr><td></td><td></td><td></td><td></td><td>46</td><td>45</td><td>43</td><td></td><td></td><td>39</td><td>37</td><td></td><td></td><td></td><td></td><td></td></tr> <tr><td></td><td>73</td><td></td><td>32</td><td>30</td><td>29</td><td>28</td><td>27</td><td></td><td></td><td>21</td><td></td><td></td><td></td><td></td><td></td></tr> <tr><td></td><td></td><td></td><td></td><td></td><td></td><td></td><td></td><td>10</td><td></td><td>6</td><td>5</td><td>4</td><td>3</td><td></td><td></td></tr> </table>			68	67		64	63			59	57										46	45	43			39	37							73		32	30	29	28	27			21														10		6	5	4	3			
		68	67		64	63			59	57																																																														
				46	45	43			39	37																																																														
	73		32	30	29	28	27			21																																																														
								10		6	5	4	3																																																											
AVAILABLE	NOT APPLICABLE	34566-2953	G	0	B	ST GRAY	<table border="1"> <tr><td></td><td></td><td>68</td><td>67</td><td></td><td>64</td><td>63</td><td></td><td></td><td>59</td><td></td><td></td><td></td><td></td><td>34</td><td></td></tr> <tr><td></td><td></td><td></td><td></td><td>46</td><td>45</td><td>43</td><td></td><td></td><td>39</td><td></td><td></td><td></td><td></td><td></td><td></td></tr> <tr><td></td><td>73</td><td></td><td>32</td><td>30</td><td>29</td><td>28</td><td>27</td><td></td><td></td><td></td><td></td><td></td><td></td><td></td><td></td></tr> <tr><td></td><td></td><td></td><td></td><td></td><td></td><td></td><td></td><td>10</td><td></td><td>6</td><td>5</td><td>4</td><td>3</td><td></td><td></td></tr> </table>			68	67		64	63			59					34						46	45	43			39								73		32	30	29	28	27																	10		6	5	4	3			
		68	67		64	63			59					34																																																										
				46	45	43			39																																																															
	73		32	30	29	28	27																																																																	
								10		6	5	4	3																																																											
AVAILABLE	NOT APPLICABLE	34566-2963	G	0	H	ST GRAY	<table border="1"> <tr><td></td><td>79</td><td></td><td></td><td>74</td><td>73</td><td>72</td><td>71</td><td>69</td><td>68</td><td>67</td><td></td><td>64</td><td>62</td><td>61</td></tr> <tr><td></td><td>59</td><td></td><td></td><td>54</td><td>53</td><td>52</td><td></td><td>49</td><td>48</td><td>47</td><td></td><td></td><td>42</td><td>41</td></tr> <tr><td></td><td></td><td>38</td><td></td><td></td><td>33</td><td></td><td></td><td>29</td><td>27</td><td>25</td><td></td><td></td><td></td><td>21</td></tr> <tr><td></td><td></td><td></td><td></td><td>15</td><td>14</td><td></td><td>11</td><td>10</td><td>9</td><td>8</td><td>7</td><td></td><td></td><td></td></tr> </table>		79			74	73	72	71	69	68	67		64	62	61		59			54	53	52		49	48	47			42	41			38			33			29	27	25				21					15	14		11	10	9	8	7								
	79			74	73	72	71	69	68	67		64	62	61																																																										
	59			54	53	52		49	48	47			42	41																																																										
		38			33			29	27	25				21																																																										
				15	14		11	10	9	8	7																																																													
AVAILABLE	NOT APPLICABLE	34566-2973	G	0	G	BLUE	<table border="1"> <tr><td>80</td><td>78</td><td>77</td><td>75</td><td>74</td><td>73</td><td>72</td><td>70</td><td>69</td><td>67</td><td>65</td><td>64</td><td>63</td><td>62</td><td></td><td></td></tr> <tr><td>60</td><td>58</td><td>57</td><td></td><td>55</td><td>54</td><td>52</td><td>51</td><td>50</td><td>49</td><td>47</td><td>45</td><td></td><td></td><td></td><td></td></tr> <tr><td>40</td><td>38</td><td>37</td><td></td><td></td><td>33</td><td>32</td><td>31</td><td></td><td></td><td>27</td><td>26</td><td>25</td><td>24</td><td></td><td></td></tr> <tr><td>20</td><td>18</td><td>17</td><td></td><td></td><td></td><td></td><td></td><td>10</td><td>9</td><td>8</td><td>6</td><td>5</td><td></td><td>3</td><td>2</td><td>1</td></tr> </table>	80	78	77	75	74	73	72	70	69	67	65	64	63	62			60	58	57		55	54	52	51	50	49	47	45					40	38	37			33	32	31			27	26	25	24			20	18	17						10	9	8	6	5		3	2	1
80	78	77	75	74	73	72	70	69	67	65	64	63	62																																																											
60	58	57		55	54	52	51	50	49	47	45																																																													
40	38	37			33	32	31			27	26	25	24																																																											
20	18	17						10	9	8	6	5		3	2	1																																																								

ENTER DESCRIPTION EC NO: UAU2016-0232 DRAWN BY: 2015/08/14 CHKD: APPR: IKOSHY REV: 2015/08/14 G34	QUALITY SYMBOLS ∇=0 ∇=0 ∇=0	GENERAL TOLERANCES (UNLESS SPECIFIED) mm INCH 4 PLACES ±--- ±--- 3 PLACES ±--- ±--- 2 PLACES ±--- ±--- 1 PLACE ±--- ±--- 0 PLACE ±--- ±--- ANGULAR ±---° DRAFT WHERE APPLICABLE MUST REMAIN WITHIN DIMENSIONS	DIMENSION STYLE MM ONLY DRAWN BY: SKRA JENDRANA DATE: 2011/02/14 CHECKED BY: MVANSLAMBROU DATE: 2011/02/14 APPROVED BY:	SCALE: TITLE: MX123 DESIGN UNITS: METRIC THIRD ANGLE PROJECTION HRNS CONN ASSY molex	MATERIAL NO.: SEE BOM TABLE DOCUMENT NO.: SD-34566-001 SHEET NO.: 34 OF 85
	THIS DRAWING CONTAINS INFORMATION THAT IS PROPRIETARY TO MOLEX INCORPORATED AND SHOULD NOT BE USED WITHOUT WRITTEN PERMISSION				
	SEE BOM TABLE				
	SD-34566-001				

STATUS	GM PART #	MATERIAL #	PART/MATERIAL REVISION	WIRE DRESS OPTION	KEY OPTION	COLOR (TPA)	NUMBERS INDICATE CAVITIES OPEN FOR CIRCUITS																																																																																		
AVAILABLE	NOT APPLICABLE	34566-9913	G	0	A	BLACK	<table border="1"> <tr><td>72</td><td>71</td><td></td><td>68</td><td>67</td><td>66</td><td>65</td><td>64</td><td></td><td></td><td></td><td>59</td><td></td><td></td><td></td><td></td><td></td><td></td><td></td><td></td></tr> <tr><td></td><td>50</td><td></td><td>48</td><td>47</td><td>46</td><td>45</td><td></td><td></td><td></td><td></td><td>40</td><td>39</td><td>38</td><td></td><td></td><td></td><td></td><td></td><td></td></tr> <tr><td>73</td><td></td><td></td><td>31</td><td>30</td><td></td><td></td><td></td><td></td><td></td><td>25</td><td>24</td><td>22</td><td>21</td><td>20</td><td></td><td></td><td></td><td></td><td>17</td></tr> <tr><td></td><td></td><td></td><td></td><td>14</td><td></td><td></td><td></td><td></td><td></td><td>9</td><td>7</td><td>6</td><td>5</td><td>4</td><td></td><td></td><td></td><td></td><td>2</td><td>1</td></tr> </table>	72	71		68	67	66	65	64				59										50		48	47	46	45					40	39	38							73			31	30						25	24	22	21	20					17					14						9	7	6	5	4					2	1	
72	71		68	67	66	65	64				59																																																																														
	50		48	47	46	45					40	39	38																																																																												
73			31	30						25	24	22	21	20					17																																																																						
				14						9	7	6	5	4					2	1																																																																					
AVAILABLE	NOT APPLICABLE	34566-9923	G	0	A	BLACK	<table border="1"> <tr><td>72</td><td>71</td><td></td><td>67</td><td>66</td><td></td><td></td><td></td><td></td><td></td><td>62</td><td>61</td><td>60</td><td></td><td>57</td><td>55</td><td>54</td><td></td><td></td><td></td></tr> <tr><td>51</td><td></td><td></td><td>48</td><td>46</td><td>45</td><td>44</td><td>43</td><td>42</td><td></td><td></td><td></td><td>39</td><td></td><td></td><td></td><td>35</td><td>33</td><td></td><td></td></tr> <tr><td>73</td><td></td><td></td><td></td><td></td><td></td><td></td><td></td><td>26</td><td>25</td><td>24</td><td></td><td></td><td></td><td></td><td></td><td></td><td></td><td></td><td></td></tr> <tr><td></td><td></td><td></td><td>15</td><td>14</td><td></td><td></td><td></td><td></td><td></td><td></td><td>8</td><td>7</td><td>6</td><td>5</td><td>4</td><td>3</td><td>2</td><td></td><td></td></tr> </table>	72	71		67	66						62	61	60		57	55	54				51			48	46	45	44	43	42				39				35	33			73								26	25	24													15	14							8	7	6	5	4	3	2				
72	71		67	66						62	61	60		57	55	54																																																																									
51			48	46	45	44	43	42				39				35	33																																																																								
73								26	25	24																																																																															
			15	14							8	7	6	5	4	3	2																																																																								
AVAILABLE	NOT APPLICABLE	34566-9933	G	0	B	ST GRY	<table border="1"> <tr><td></td><td></td><td>69</td><td></td><td></td><td>65</td><td>64</td><td>63</td><td></td><td></td><td></td><td></td><td></td><td></td><td></td><td></td><td></td><td></td><td></td><td></td><td></td></tr> <tr><td></td><td></td><td>49</td><td></td><td></td><td>45</td><td>44</td><td>43</td><td></td><td></td><td></td><td></td><td></td><td></td><td></td><td></td><td></td><td></td><td></td><td></td><td></td></tr> <tr><td>73</td><td></td><td></td><td></td><td></td><td></td><td></td><td></td><td></td><td></td><td></td><td></td><td></td><td></td><td>22</td><td>21</td><td>20</td><td>19</td><td>18</td><td>17</td></tr> <tr><td></td><td></td><td></td><td></td><td></td><td>12</td><td>11</td><td></td><td></td><td></td><td></td><td></td><td></td><td></td><td>6</td><td>5</td><td>4</td><td>3</td><td>2</td><td>1</td></tr> </table>			69			65	64	63																49			45	44	43														73														22	21	20	19	18	17						12	11								6	5	4	3	2	1
		69			65	64	63																																																																																		
		49			45	44	43																																																																																		
73														22	21	20	19	18	17																																																																						
					12	11								6	5	4	3	2	1																																																																						
AVAILABLE	NOT APPLICABLE	34566-9943	G	0	C	BLUE	<table border="1"> <tr><td>71</td><td>69</td><td></td><td></td><td>65</td><td>64</td><td></td><td></td><td>61</td><td>60</td><td></td><td>58</td><td></td><td>56</td><td>55</td><td>54</td><td></td><td></td><td></td><td></td></tr> <tr><td>50</td><td>49</td><td></td><td></td><td>45</td><td>43</td><td></td><td></td><td>41</td><td></td><td></td><td></td><td></td><td>37</td><td>36</td><td>35</td><td></td><td></td><td></td><td></td></tr> <tr><td>73</td><td></td><td></td><td>31</td><td>29</td><td>28</td><td></td><td></td><td>24</td><td>23</td><td></td><td></td><td></td><td></td><td></td><td>19</td><td>18</td><td>17</td><td></td><td></td></tr> <tr><td></td><td></td><td></td><td>16</td><td></td><td>13</td><td>12</td><td>11</td><td></td><td>8</td><td>7</td><td></td><td></td><td></td><td></td><td>3</td><td>2</td><td>1</td><td></td><td></td></tr> </table>	71	69			65	64			61	60		58		56	55	54					50	49			45	43			41					37	36	35					73			31	29	28			24	23						19	18	17						16		13	12	11		8	7					3	2	1				
71	69			65	64			61	60		58		56	55	54																																																																										
50	49			45	43			41					37	36	35																																																																										
73			31	29	28			24	23						19	18	17																																																																								
			16		13	12	11		8	7					3	2	1																																																																								
AVAILABLE	NOT APPLICABLE	34566-9953	G	0	A	BLACK	<table border="1"> <tr><td></td><td></td><td>67</td><td></td><td></td><td></td><td></td><td></td><td>62</td><td>60</td><td></td><td>57</td><td>55</td><td></td><td></td><td></td><td></td><td></td><td></td><td></td></tr> <tr><td>51</td><td></td><td>48</td><td>46</td><td>45</td><td>44</td><td>43</td><td></td><td></td><td></td><td>39</td><td></td><td></td><td></td><td></td><td>35</td><td></td><td></td><td></td><td></td></tr> <tr><td>73</td><td></td><td></td><td></td><td></td><td></td><td></td><td></td><td></td><td>25</td><td></td><td></td><td></td><td></td><td></td><td></td><td></td><td></td><td></td><td></td></tr> <tr><td></td><td></td><td>15</td><td>14</td><td></td><td></td><td></td><td></td><td></td><td></td><td>7</td><td>6</td><td>5</td><td>4</td><td>3</td><td>2</td><td></td><td></td><td></td><td></td></tr> </table>			67						62	60		57	55								51		48	46	45	44	43				39					35					73									25													15	14							7	6	5	4	3	2						
		67						62	60		57	55																																																																													
51		48	46	45	44	43				39					35																																																																										
73									25																																																																																
		15	14							7	6	5	4	3	2																																																																										
AVAILABLE	NOT APPLICABLE	34566-9963	G	0	B	ST GRY	<table border="1"> <tr><td></td><td></td><td>68</td><td>67</td><td></td><td>64</td><td>63</td><td></td><td></td><td></td><td></td><td>58</td><td></td><td>55</td><td></td><td></td><td></td><td></td><td></td><td></td></tr> <tr><td></td><td></td><td></td><td>46</td><td>45</td><td>43</td><td></td><td></td><td></td><td></td><td></td><td></td><td></td><td>38</td><td>35</td><td></td><td></td><td></td><td></td><td></td></tr> <tr><td>73</td><td></td><td>32</td><td>30</td><td>29</td><td>28</td><td>27</td><td></td><td></td><td></td><td></td><td></td><td></td><td>22</td><td>19</td><td>17</td><td></td><td></td><td></td><td></td></tr> <tr><td></td><td></td><td>15</td><td>13</td><td></td><td></td><td>10</td><td></td><td></td><td></td><td></td><td></td><td></td><td></td><td></td><td></td><td></td><td></td><td></td><td>1</td></tr> </table>			68	67		64	63					58		55										46	45	43								38	35						73		32	30	29	28	27							22	19	17							15	13			10													1		
		68	67		64	63					58		55																																																																												
			46	45	43								38	35																																																																											
73		32	30	29	28	27							22	19	17																																																																										
		15	13			10													1																																																																						
AVAILABLE	NOT APPLICABLE	34566-9973	G	0	B	ST GRY	<table border="1"> <tr><td></td><td></td><td>68</td><td>67</td><td></td><td>64</td><td>63</td><td></td><td></td><td></td><td></td><td>58</td><td></td><td></td><td></td><td></td><td></td><td></td><td></td><td></td></tr> <tr><td></td><td></td><td></td><td>46</td><td>45</td><td>43</td><td></td><td></td><td></td><td></td><td></td><td></td><td></td><td>38</td><td></td><td></td><td></td><td></td><td></td><td></td></tr> <tr><td>73</td><td></td><td>32</td><td>30</td><td>29</td><td>28</td><td>27</td><td></td><td></td><td></td><td></td><td></td><td></td><td>22</td><td></td><td></td><td></td><td></td><td></td><td>17</td></tr> <tr><td></td><td></td><td>15</td><td>13</td><td></td><td></td><td>10</td><td></td><td></td><td></td><td></td><td></td><td></td><td></td><td></td><td></td><td></td><td></td><td></td><td></td></tr> </table>			68	67		64	63					58												46	45	43								38							73		32	30	29	28	27							22						17			15	13			10															
		68	67		64	63					58																																																																														
			46	45	43								38																																																																												
73		32	30	29	28	27							22						17																																																																						
		15	13			10																																																																																			

ENTER DESCRIPTION EC NO: UAU2016-0232 DRAWN BY: CHKD APPR: WJOSHY 2015/08/14 2015/08/14 G34	QUALITY SYMBOLS ∇=0 ∇=0 ∇=0	GENERAL TOLERANCES (UNLESS SPECIFIED) <table border="1"> <tr><td></td><td>mm</td><td>INCH</td></tr> <tr><td>4 PLACES</td><td>±---</td><td>±---</td></tr> <tr><td>3 PLACES</td><td>±---</td><td>±---</td></tr> <tr><td>2 PLACES</td><td>±---</td><td>±---</td></tr> <tr><td>1 PLACE</td><td>±---</td><td>±---</td></tr> <tr><td>0 PLACE</td><td>±---</td><td>±---</td></tr> </table>		mm	INCH	4 PLACES	±---	±---	3 PLACES	±---	±---	2 PLACES	±---	±---	1 PLACE	±---	±---	0 PLACE	±---	±---	DIMENSION STYLE MM ONLY	SCALE DESIGN UNITS METRIC	THIRD ANGLE PROJECTION
		mm	INCH																				
	4 PLACES	±---	±---																				
	3 PLACES	±---	±---																				
2 PLACES	±---	±---																					
1 PLACE	±---	±---																					
0 PLACE	±---	±---																					
MATERIAL NO. DRAWN BY: SKRAJENDRANA CHECKED BY: MVANSLAMBROU APPROVED BY:	DATE 2011/02/14 2011/02/14 DATE	TITLE MX123 66/73/80CKT HRNS CONN ASSY	SEE BOM TABLE	DOCUMENT NO. SD-34566-001	SHEET NO. 35 OF 85																		
DRAFT WHERE APPLICABLE MUST REMAIN WITHIN DIMENSIONS																							
THIS DRAWING CONTAINS INFORMATION THAT IS PROPRIETARY TO MOLEX INCORPORATED AND SHOULD NOT BE USED WITHOUT WRITTEN PERMISSION																							

STATUS	GM PART #	MATERIAL #	PART/MATERIAL REVISION	WIRE DRESS OPTION	KEY OPTION	COLOR (TPA)	NUMBERS INDICATE CAVITIES OPEN FOR CIRCUITS																																																																																																																
AVAILABLE	NOT APPLICABLE	34566-2983	G	9	A	BLACK	<table border="1"> <tr><td></td><td></td><td>70</td><td>69</td><td></td><td></td><td></td><td></td><td></td><td></td><td>63</td><td>62</td><td>61</td><td></td><td></td><td>58</td><td>57</td><td>56</td><td>55</td><td>54</td><td>53</td></tr> <tr><td>52</td><td>51</td><td></td><td>49</td><td></td><td></td><td></td><td></td><td></td><td></td><td>44</td><td>43</td><td>42</td><td>41</td><td></td><td></td><td>37</td><td>36</td><td></td><td></td><td>34</td></tr> <tr><td></td><td></td><td>73</td><td></td><td></td><td></td><td></td><td></td><td></td><td></td><td></td><td></td><td></td><td></td><td></td><td></td><td></td><td></td><td></td><td>19</td><td>18</td><td>17</td></tr> <tr><td></td><td></td><td></td><td></td><td>32</td><td></td><td></td><td></td><td></td><td></td><td>29</td><td>28</td><td>27</td><td>26</td><td></td><td></td><td></td><td></td><td></td><td></td><td></td><td>3</td><td>2</td><td>1</td></tr> <tr><td></td><td></td><td></td><td></td><td></td><td>16</td><td>15</td><td></td><td></td><td></td><td>13</td><td>12</td><td>11</td><td>10</td><td></td><td></td><td></td><td></td><td></td><td></td><td></td><td></td><td></td><td></td></tr> </table>			70	69							63	62	61			58	57	56	55	54	53	52	51		49							44	43	42	41			37	36			34			73																	19	18	17					32						29	28	27	26								3	2	1						16	15				13	12	11	10										
		70	69							63	62	61			58	57	56	55	54	53																																																																																																			
52	51		49							44	43	42	41			37	36			34																																																																																																			
		73																	19	18	17																																																																																																		
				32						29	28	27	26								3	2	1																																																																																																
					16	15				13	12	11	10																																																																																																										
AVAILABLE	NOT APPLICABLE	34566-2993	G	9	B	ST GRY	<table border="1"> <tr><td>72</td><td>71</td><td>70</td><td></td><td>68</td><td>67</td><td>66</td><td></td><td></td><td></td><td>62</td><td>61</td><td>60</td><td>59</td><td>58</td><td>57</td><td>56</td><td>55</td><td>54</td><td>53</td></tr> <tr><td>52</td><td>51</td><td>50</td><td></td><td>48</td><td>47</td><td>46</td><td></td><td></td><td></td><td>42</td><td>41</td><td>40</td><td>39</td><td>38</td><td>37</td><td>36</td><td>35</td><td>34</td><td>33</td></tr> <tr><td></td><td></td><td>73</td><td></td><td></td><td></td><td></td><td></td><td></td><td></td><td></td><td></td><td></td><td></td><td></td><td></td><td></td><td></td><td></td><td></td><td></td></tr> <tr><td></td><td></td><td></td><td></td><td>32</td><td>31</td><td>30</td><td>29</td><td>28</td><td>27</td><td>26</td><td>25</td><td>24</td><td></td><td></td><td></td><td></td><td></td><td></td><td></td><td></td></tr> <tr><td></td><td></td><td></td><td></td><td></td><td>16</td><td>15</td><td>14</td><td>13</td><td></td><td></td><td>10</td><td>9</td><td>8</td><td></td><td></td><td></td><td></td><td></td><td></td><td></td></tr> </table>	72	71	70		68	67	66				62	61	60	59	58	57	56	55	54	53	52	51	50		48	47	46				42	41	40	39	38	37	36	35	34	33			73																							32	31	30	29	28	27	26	25	24														16	15	14	13			10	9	8																
72	71	70		68	67	66				62	61	60	59	58	57	56	55	54	53																																																																																																				
52	51	50		48	47	46				42	41	40	39	38	37	36	35	34	33																																																																																																				
		73																																																																																																																					
				32	31	30	29	28	27	26	25	24																																																																																																											
					16	15	14	13			10	9	8																																																																																																										
AVAILABLE	NOT APPLICABLE	34566-3013	G	9	C	BLUE	<table border="1"> <tr><td>72</td><td>71</td><td>70</td><td>69</td><td>68</td><td>67</td><td>66</td><td></td><td></td><td></td><td>63</td><td>62</td><td></td><td>59</td><td></td><td>57</td><td>56</td><td>55</td><td></td><td>53</td></tr> <tr><td>52</td><td>51</td><td></td><td></td><td></td><td></td><td></td><td></td><td></td><td></td><td>46</td><td>44</td><td></td><td>42</td><td>40</td><td>39</td><td>38</td><td></td><td></td><td>34</td><td>33</td></tr> <tr><td></td><td></td><td>73</td><td></td><td></td><td></td><td></td><td></td><td></td><td></td><td></td><td></td><td></td><td></td><td></td><td></td><td></td><td></td><td></td><td>19</td><td>18</td></tr> <tr><td></td><td></td><td></td><td></td><td>32</td><td></td><td>30</td><td></td><td></td><td></td><td>26</td><td>25</td><td></td><td></td><td>22</td><td>21</td><td></td><td></td><td></td><td></td><td></td></tr> <tr><td></td><td></td><td></td><td></td><td></td><td>15</td><td>14</td><td></td><td></td><td></td><td>10</td><td>9</td><td></td><td></td><td>6</td><td>5</td><td>4</td><td>3</td><td></td><td></td><td></td></tr> </table>	72	71	70	69	68	67	66				63	62		59		57	56	55		53	52	51									46	44		42	40	39	38			34	33			73																	19	18					32		30				26	25			22	21											15	14				10	9			6	5	4	3											
72	71	70	69	68	67	66				63	62		59		57	56	55		53																																																																																																				
52	51									46	44		42	40	39	38			34	33																																																																																																			
		73																	19	18																																																																																																			
				32		30				26	25			22	21																																																																																																								
					15	14				10	9			6	5	4	3																																																																																																						
AVAILABLE	NOT APPLICABLE	34566-3023	G	0	G	BLUE	<table border="1"> <tr><td></td><td>79</td><td></td><td></td><td>76</td><td></td><td></td><td></td><td></td><td></td><td>71</td><td></td><td></td><td>68</td><td>66</td><td></td><td></td><td></td><td></td><td></td><td>61</td></tr> <tr><td></td><td>59</td><td></td><td></td><td>56</td><td></td><td></td><td>53</td><td></td><td></td><td></td><td></td><td></td><td>48</td><td>46</td><td></td><td>44</td><td>43</td><td>42</td><td>41</td></tr> <tr><td></td><td>39</td><td></td><td></td><td>36</td><td>35</td><td>34</td><td></td><td></td><td></td><td>30</td><td>29</td><td>28</td><td></td><td></td><td></td><td></td><td></td><td>23</td><td>22</td><td>21</td></tr> <tr><td></td><td>19</td><td></td><td></td><td>16</td><td>15</td><td>14</td><td>13</td><td>12</td><td>11</td><td></td><td></td><td></td><td>7</td><td></td><td></td><td>4</td><td></td><td></td><td></td><td></td></tr> </table>		79			76						71			68	66						61		59			56			53						48	46		44	43	42	41		39			36	35	34				30	29	28						23	22	21		19			16	15	14	13	12	11				7			4																																	
	79			76						71			68	66						61																																																																																																			
	59			56			53						48	46		44	43	42	41																																																																																																				
	39			36	35	34				30	29	28						23	22	21																																																																																																			
	19			16	15	14	13	12	11				7			4																																																																																																							
AVAILABLE	NOT APPLICABLE	34566-3033	G	0	H	ST GRY	<table border="1"> <tr><td>80</td><td>78</td><td>77</td><td>76</td><td>75</td><td></td><td></td><td></td><td></td><td></td><td>70</td><td></td><td></td><td></td><td>66</td><td>65</td><td></td><td>63</td><td></td><td></td></tr> <tr><td>60</td><td>58</td><td>57</td><td>56</td><td>55</td><td></td><td></td><td></td><td></td><td></td><td>51</td><td>50</td><td></td><td></td><td>46</td><td>45</td><td>44</td><td>43</td><td></td><td></td></tr> <tr><td>40</td><td>39</td><td></td><td>37</td><td>36</td><td>35</td><td>34</td><td></td><td></td><td></td><td>32</td><td>31</td><td>30</td><td></td><td>28</td><td>26</td><td></td><td>24</td><td>23</td><td>22</td></tr> <tr><td>20</td><td>19</td><td>18</td><td>17</td><td>16</td><td></td><td></td><td></td><td></td><td></td><td>13</td><td>12</td><td></td><td></td><td>6</td><td>5</td><td>4</td><td>3</td><td>2</td><td>1</td></tr> </table>	80	78	77	76	75						70				66	65		63			60	58	57	56	55						51	50			46	45	44	43			40	39		37	36	35	34				32	31	30		28	26		24	23	22	20	19	18	17	16						13	12			6	5	4	3	2	1																																
80	78	77	76	75						70				66	65		63																																																																																																						
60	58	57	56	55						51	50			46	45	44	43																																																																																																						
40	39		37	36	35	34				32	31	30		28	26		24	23	22																																																																																																				
20	19	18	17	16						13	12			6	5	4	3	2	1																																																																																																				
AVAILABLE	NOT APPLICABLE	34566-3043	G	0	C	BLUE	<table border="1"> <tr><td>72</td><td>70</td><td></td><td>68</td><td></td><td>66</td><td></td><td></td><td></td><td></td><td>63</td><td>62</td><td></td><td>59</td><td></td><td>57</td><td></td><td></td><td></td><td>53</td></tr> <tr><td>52</td><td>51</td><td></td><td>48</td><td>47</td><td>46</td><td></td><td></td><td></td><td></td><td>44</td><td>42</td><td></td><td>40</td><td>39</td><td></td><td></td><td></td><td></td><td>34</td><td>33</td></tr> <tr><td></td><td></td><td>73</td><td></td><td></td><td></td><td></td><td></td><td></td><td></td><td></td><td></td><td></td><td></td><td></td><td></td><td></td><td></td><td></td><td></td><td></td></tr> <tr><td></td><td></td><td></td><td>32</td><td></td><td>30</td><td></td><td></td><td></td><td></td><td>27</td><td>26</td><td>25</td><td></td><td></td><td>22</td><td>21</td><td>20</td><td></td><td></td></tr> <tr><td></td><td></td><td></td><td></td><td>15</td><td>14</td><td>13</td><td></td><td></td><td></td><td>10</td><td>9</td><td></td><td></td><td>6</td><td>5</td><td>4</td><td></td><td></td><td></td><td></td></tr> </table>	72	70		68		66					63	62		59		57				53	52	51		48	47	46					44	42		40	39					34	33			73																						32		30					27	26	25			22	21	20							15	14	13				10	9			6	5	4													
72	70		68		66					63	62		59		57				53																																																																																																				
52	51		48	47	46					44	42		40	39					34	33																																																																																																			
		73																																																																																																																					
			32		30					27	26	25			22	21	20																																																																																																						
				15	14	13				10	9			6	5	4																																																																																																							
AVAILABLE	NOT APPLICABLE	34566-3053	G	0	C	BLUE	<table border="1"> <tr><td>72</td><td>70</td><td></td><td>68</td><td></td><td>66</td><td></td><td></td><td></td><td></td><td>63</td><td>62</td><td></td><td>59</td><td></td><td>57</td><td></td><td></td><td></td><td>53</td></tr> <tr><td>52</td><td>51</td><td></td><td>48</td><td>47</td><td>46</td><td></td><td></td><td></td><td></td><td>44</td><td>42</td><td></td><td>40</td><td>39</td><td>38</td><td></td><td></td><td></td><td>34</td><td>33</td></tr> <tr><td></td><td></td><td>73</td><td></td><td></td><td></td><td></td><td></td><td></td><td></td><td></td><td></td><td></td><td></td><td></td><td></td><td></td><td></td><td></td><td></td><td></td></tr> <tr><td></td><td></td><td></td><td>32</td><td></td><td>30</td><td></td><td></td><td></td><td></td><td>27</td><td>26</td><td>25</td><td></td><td></td><td>22</td><td>21</td><td>20</td><td></td><td></td></tr> <tr><td></td><td></td><td></td><td></td><td>15</td><td>14</td><td>13</td><td></td><td></td><td></td><td>10</td><td>9</td><td></td><td></td><td>6</td><td>5</td><td>4</td><td></td><td></td><td></td><td></td></tr> </table>	72	70		68		66					63	62		59		57				53	52	51		48	47	46					44	42		40	39	38				34	33			73																						32		30					27	26	25			22	21	20							15	14	13				10	9			6	5	4													
72	70		68		66					63	62		59		57				53																																																																																																				
52	51		48	47	46					44	42		40	39	38				34	33																																																																																																			
		73																																																																																																																					
			32		30					27	26	25			22	21	20																																																																																																						
				15	14	13				10	9			6	5	4																																																																																																							
AVAILABLE	NOT APPLICABLE	34566-3063	G	0	A	BLACK	<table border="1"> <tr><td></td><td>71</td><td></td><td>69</td><td></td><td></td><td></td><td></td><td></td><td></td><td>65</td><td>64</td><td>63</td><td></td><td></td><td>60</td><td>58</td><td>57</td><td>56</td><td>55</td><td>54</td><td>53</td></tr> <tr><td>52</td><td>51</td><td></td><td>49</td><td></td><td></td><td></td><td></td><td></td><td></td><td>45</td><td>44</td><td>43</td><td>42</td><td>41</td><td></td><td></td><td>37</td><td>36</td><td>35</td><td>34</td><td>33</td></tr> <tr><td></td><td></td><td>73</td><td></td><td></td><td></td><td></td><td></td><td></td><td></td><td></td><td></td><td></td><td></td><td></td><td></td><td></td><td></td><td></td><td></td><td>19</td><td>18</td></tr> <tr><td></td><td></td><td></td><td></td><td>32</td><td></td><td>30</td><td></td><td></td><td></td><td>28</td><td>26</td><td></td><td></td><td></td><td></td><td></td><td></td><td></td><td></td><td></td><td></td><td>3</td></tr> <tr><td></td><td></td><td></td><td></td><td></td><td>16</td><td></td><td></td><td></td><td></td><td>12</td><td>10</td><td></td><td></td><td></td><td></td><td></td><td></td><td></td><td></td><td></td><td></td><td></td></tr> </table>		71		69							65	64	63			60	58	57	56	55	54	53	52	51		49							45	44	43	42	41			37	36	35	34	33			73																		19	18					32		30				28	26											3						16					12	10											
	71		69							65	64	63			60	58	57	56	55	54	53																																																																																																		
52	51		49							45	44	43	42	41			37	36	35	34	33																																																																																																		
		73																		19	18																																																																																																		
				32		30				28	26											3																																																																																																	
					16					12	10																																																																																																												

ENTER DESCRIPTION REC NO: UAU2016-0232 DRAWN BY: 2015/08/14 CHKD: GJ34 APPR: WOSHY REV: 2015/08/14	QUALITY SYMBOLS	GENERAL TOLERANCES (UNLESS SPECIFIED)	DIMENSION STYLE	SCALE	DESIGN UNITS	THIRD ANGLE PROJECTION	
	$\nabla=0$ $\nabla=0$ $\nabla=0$	4 PLACES ±---+--- 3 PLACES ±---+--- 2 PLACES ±---+--- 1 PLACE ±---+--- 0 PLACE ±---+---	mm INCH ±---+--- ±---+--- ±---+--- ±---+--- ±---+--- ±---+--- ±---+--- ±---+---	MM ONLY DRAWN BY: SKRAJENDRANA DATE: 2011/02/14 CHECKED BY: MYANSLAMBROU DATE: 2011/02/14 APPROVED BY:	TITLE: MX123 66/73/80CKT HRNS CONN ASSY	METRIC	
	ANGULAR ±---+--- DRAFT WHERE APPLICABLE MUST REMAIN WITHIN DIMENSIONS	MATERIAL NO. SEE BOM TABLE DOCUMENT NO. SD-34566-001	SHEET NO. 36 OF 85				
	THIS DRAWING CONTAINS INFORMATION THAT IS PROPRIETARY TO MOLEX INCORPORATED AND SHOULD NOT BE USED WITHOUT WRITTEN PERMISSION						

STATUS	GM PART #	MATERIAL #	PART/ MATERIAL REVISION	WIRE DRESS OPTION	KEY OPTION ▽	COLOR (TPA) ▽	NUMBERS INDICATE CAVITIES OPEN FOR CIRCUITS ▽																																																												
AVAILABLE	NOT APPLICABLE	34566-3073	G	0	A	BLACK	71	69			65	64	63		60		57	56	55	54	53	52	51	49			45	44	43	42	41			37	36	35	34	33	73		32	30	28	26		23			19	18			16			12	10	8	7	6				3			
AVAILABLE	NOT APPLICABLE	34566-3083	G	0	A	BLACK	71	69			65	64	63		60		58	57	56	55	54	53	52	51	49			45	44	43	42	41			37	36	35	34	33	73		32	30	28	26					19	18			16			11	10						3			
AVAILABLE	NOT APPLICABLE	34566-3093	G	0	A	BLACK	71	69			64	63	62		60		57	56	55	54	53	52	51	49			45	44	43	42	41			37	36	35	34	33	73		32	30	28	26		23			19	18			16			12	10					3					
AVAILABLE	NOT APPLICABLE	34566-3113	G	0	A	BLACK	71	69			65	64	63		60		57	56	55	54	53	52	51	49			45	44	43	42	41			37	36	35	34	33	73		32	30	28	26		23			21	19	18			16			12	10	8		5	3					
AVAILABLE	NOT APPLICABLE	34566-3123	G	0	B	ST GRY	72	70	68	66					60	59			55	54	53	52	51	50	48	46					40	39			35	34	33	73		32	31	30	29	28	27	26	25	24																			
AVAILABLE	NOT APPLICABLE	34566-3133	G	0	C	BLUE	72	70	68	67	66			63	62		59	57			53	52	51		48	47	46	44	42	40	39			34	33	73		32		30			26	25			22	21	20																		
AVAILABLE	NOT APPLICABLE	34566-3143	G	0	C	BLUE	72	70			66			63	62		59	57			53	52	51			46	44	42	40	39	37	36	34	33	73		32		30			26	25			22	21																				
AVAILABLE	NOT APPLICABLE	34566-3153	G	0	A	BLACK		70	69						63			58	56	54	52	51	49		47		44	43	42	41			36	34	73		32			28	26					19	18			16									3								

ENTER DESCRIPTION EC NO: UAU2016-0232 DRAWN BY: 2015/08/14 CHKD: 2015/08/14 APPR: IKOSHY REV: GJ4	QUALITY SYMBOLS ▽=0 ▽=0 ▽=0	GENERAL TOLERANCES (UNLESS SPECIFIED): mm INCH 4 PLACES ±--- ±--- 3 PLACES ±--- ±--- 2 PLACES ±--- ±--- 1 PLACE ±--- ±--- 0 PLACE ±--- ±---	DIMENSION STYLE MM ONLY	SCALE DESIGN UNITS METRIC	THIRD ANGLE PROJECTION 	
	DRAWN BY: SKRAJENDRANA 2011/02/14 CHECKED BY: MYANSLAMBROU 2011/02/14 APPROVED BY:	DATE:	TITLE MX123 66/73/80CKT HRNS CONN ASSY	MATERIAL NO. SEE BOM TABLE	DOCUMENT NO. SD-34566-001	SHEET NO. 37 OF 85
	DRAFT WHERE APPLICABLE MUST REMAIN WITHIN DIMENSIONS			THIS DRAWING CONTAINS INFORMATION THAT IS PROPRIETARY TO MOLEX INCORPORATED AND SHOULD NOT BE USED WITHOUT WRITTEN PERMISSION		
	MOLEX					

STATUS	GM PART #	MATERIAL #	PART/MATERIAL REVISION	WIRE DRESS OPTION	KEY OPTION	COLOR (TPA)	NUMBERS INDICATE CAVITIES OPEN FOR CIRCUITS																																																																			
AVAILABLE	NOT APPLICABLE	34566-3163	G	0	C	BLUE	<table border="1"> <tr><td>72</td><td>70</td><td></td><td></td><td></td><td></td><td>63</td><td>62</td><td></td><td>59</td><td>57</td><td>56</td><td>55</td><td>53</td></tr> <tr><td>52</td><td>51</td><td></td><td></td><td></td><td>46</td><td>44</td><td>42</td><td>40</td><td>39</td><td>37</td><td>36</td><td></td><td>34</td><td>33</td></tr> <tr><td></td><td></td><td>73</td><td></td><td></td><td>32</td><td>30</td><td></td><td>26</td><td>25</td><td></td><td>22</td><td>21</td><td>19</td><td>18</td></tr> <tr><td></td><td></td><td></td><td></td><td></td><td>15</td><td>14</td><td></td><td>10</td><td>9</td><td></td><td>6</td><td></td><td>3</td><td></td></tr> </table>	72	70					63	62		59	57	56	55	53	52	51				46	44	42	40	39	37	36		34	33			73			32	30		26	25		22	21	19	18						15	14		10	9		6		3									
72	70					63	62		59	57	56	55	53																																																													
52	51				46	44	42	40	39	37	36		34	33																																																												
		73			32	30		26	25		22	21	19	18																																																												
					15	14		10	9		6		3																																																													
AVAILABLE	NOT APPLICABLE	34566-3173	G	0	A	BLACK	<table border="1"> <tr><td></td><td>70</td><td>69</td><td></td><td></td><td></td><td>63</td><td></td><td></td><td></td><td>58</td><td>56</td><td>55</td><td>54</td><td></td></tr> <tr><td>52</td><td>51</td><td>49</td><td></td><td></td><td>47</td><td></td><td>44</td><td>43</td><td>42</td><td>41</td><td></td><td></td><td>36</td><td>34</td></tr> <tr><td></td><td></td><td></td><td>73</td><td></td><td>32</td><td></td><td>28</td><td>26</td><td></td><td></td><td></td><td></td><td>19</td><td>18</td></tr> <tr><td></td><td></td><td></td><td></td><td></td><td>16</td><td></td><td>12</td><td>10</td><td></td><td></td><td></td><td></td><td>3</td><td>2</td></tr> </table>		70	69				63				58	56	55	54		52	51	49			47		44	43	42	41			36	34				73		32		28	26					19	18						16		12	10					3	2							
	70	69				63				58	56	55	54																																																													
52	51	49			47		44	43	42	41			36	34																																																												
			73		32		28	26					19	18																																																												
					16		12	10					3	2																																																												
AVAILABLE	NOT APPLICABLE	34566-3183	G	0	C	BLUE	<table border="1"> <tr><td>72</td><td>70</td><td></td><td></td><td></td><td>66</td><td></td><td>63</td><td>62</td><td></td><td>59</td><td>57</td><td>56</td><td>55</td><td>53</td></tr> <tr><td>52</td><td>51</td><td></td><td></td><td></td><td>46</td><td>44</td><td>42</td><td>40</td><td>39</td><td></td><td></td><td></td><td></td><td>34</td><td>33</td></tr> <tr><td></td><td></td><td>73</td><td></td><td></td><td>30</td><td></td><td></td><td>26</td><td>25</td><td></td><td>22</td><td>21</td><td></td><td></td><td></td></tr> <tr><td></td><td></td><td></td><td></td><td></td><td>15</td><td>14</td><td></td><td>10</td><td>9</td><td></td><td>6</td><td></td><td></td><td></td><td></td></tr> </table>	72	70				66		63	62		59	57	56	55	53	52	51				46	44	42	40	39					34	33			73			30			26	25		22	21									15	14		10	9		6								
72	70				66		63	62		59	57	56	55	53																																																												
52	51				46	44	42	40	39					34	33																																																											
		73			30			26	25		22	21																																																														
					15	14		10	9		6																																																															
AVAILABLE	NOT APPLICABLE	34566-3193	G	0	A	BLACK	<table border="1"> <tr><td></td><td></td><td>69</td><td></td><td></td><td></td><td>63</td><td></td><td></td><td></td><td>58</td><td>56</td><td>55</td><td>54</td><td>53</td></tr> <tr><td>52</td><td>51</td><td>49</td><td></td><td></td><td></td><td>44</td><td>43</td><td>42</td><td>41</td><td></td><td></td><td>36</td><td>35</td><td>34</td><td>33</td></tr> <tr><td></td><td></td><td></td><td>73</td><td></td><td>32</td><td></td><td>28</td><td>26</td><td></td><td></td><td></td><td></td><td>19</td><td>18</td><td>17</td></tr> <tr><td></td><td></td><td></td><td></td><td></td><td>16</td><td></td><td>12</td><td>10</td><td></td><td></td><td></td><td></td><td>3</td><td>2</td><td>1</td></tr> </table>			69				63				58	56	55	54	53	52	51	49				44	43	42	41			36	35	34	33				73		32		28	26					19	18	17						16		12	10					3	2	1				
		69				63				58	56	55	54	53																																																												
52	51	49				44	43	42	41			36	35	34	33																																																											
			73		32		28	26					19	18	17																																																											
					16		12	10					3	2	1																																																											
AVAILABLE	NOT APPLICABLE	34566-3213	G	0	C	BLUE	<table border="1"> <tr><td>72</td><td>70</td><td></td><td></td><td></td><td>67</td><td>66</td><td></td><td>63</td><td>62</td><td></td><td>59</td><td></td><td>56</td><td></td><td>53</td></tr> <tr><td>52</td><td>51</td><td></td><td></td><td></td><td>46</td><td>44</td><td></td><td>42</td><td>40</td><td></td><td></td><td></td><td></td><td></td><td>34</td><td>33</td></tr> <tr><td></td><td></td><td>73</td><td></td><td></td><td>32</td><td>30</td><td></td><td></td><td>26</td><td>25</td><td></td><td>22</td><td>21</td><td></td><td></td><td></td></tr> <tr><td></td><td></td><td></td><td></td><td></td><td>15</td><td>14</td><td></td><td></td><td>10</td><td>9</td><td></td><td>6</td><td>5</td><td>4</td><td></td><td></td></tr> </table>	72	70				67	66		63	62		59		56		53	52	51				46	44		42	40						34	33			73			32	30			26	25		22	21									15	14			10	9		6	5	4		
72	70				67	66		63	62		59		56		53																																																											
52	51				46	44		42	40						34	33																																																										
		73			32	30			26	25		22	21																																																													
					15	14			10	9		6	5	4																																																												
AVAILABLE	NOT APPLICABLE	34566-3223	G	0	C	BLUE	<table border="1"> <tr><td>72</td><td>70</td><td></td><td></td><td></td><td>67</td><td>66</td><td></td><td>63</td><td>62</td><td></td><td>59</td><td>57</td><td></td><td></td><td>53</td></tr> <tr><td>52</td><td>51</td><td></td><td></td><td></td><td>46</td><td>44</td><td></td><td>42</td><td>40</td><td>39</td><td></td><td></td><td></td><td></td><td>34</td><td>33</td></tr> <tr><td></td><td></td><td>73</td><td></td><td></td><td>32</td><td>30</td><td></td><td>27</td><td>26</td><td>25</td><td></td><td>22</td><td>21</td><td></td><td></td><td></td></tr> <tr><td></td><td></td><td></td><td></td><td></td><td>15</td><td>14</td><td></td><td></td><td>10</td><td>9</td><td></td><td>6</td><td>5</td><td>4</td><td></td><td></td></tr> </table>	72	70				67	66		63	62		59	57			53	52	51				46	44		42	40	39					34	33			73			32	30		27	26	25		22	21									15	14			10	9		6	5	4		
72	70				67	66		63	62		59	57			53																																																											
52	51				46	44		42	40	39					34	33																																																										
		73			32	30		27	26	25		22	21																																																													
					15	14			10	9		6	5	4																																																												
AVAILABLE	NOT APPLICABLE	34566-3233	G	0	A	BLACK	<table border="1"> <tr><td></td><td>70</td><td>69</td><td></td><td></td><td></td><td>63</td><td>62</td><td>61</td><td></td><td>58</td><td>57</td><td>56</td><td>55</td><td>54</td><td>53</td></tr> <tr><td>52</td><td>51</td><td>49</td><td></td><td></td><td></td><td>44</td><td>43</td><td>42</td><td>41</td><td></td><td></td><td>37</td><td>36</td><td></td><td>34</td></tr> <tr><td></td><td></td><td></td><td>73</td><td></td><td>32</td><td></td><td>29</td><td>28</td><td>27</td><td>26</td><td></td><td></td><td></td><td>19</td><td>18</td></tr> <tr><td></td><td></td><td></td><td></td><td></td><td>16</td><td>15</td><td>13</td><td>12</td><td>11</td><td>10</td><td></td><td></td><td></td><td>3</td><td></td></tr> </table>		70	69				63	62	61		58	57	56	55	54	53	52	51	49				44	43	42	41			37	36		34				73		32		29	28	27	26				19	18						16	15	13	12	11	10				3				
	70	69				63	62	61		58	57	56	55	54	53																																																											
52	51	49				44	43	42	41			37	36		34																																																											
			73		32		29	28	27	26				19	18																																																											
					16	15	13	12	11	10				3																																																												
AVAILABLE	NOT APPLICABLE	34566-3243	G	0	C	BLUE	<table border="1"> <tr><td>72</td><td>70</td><td></td><td></td><td></td><td>66</td><td></td><td>63</td><td>62</td><td></td><td>59</td><td>57</td><td></td><td></td><td>53</td></tr> <tr><td>52</td><td>51</td><td></td><td></td><td></td><td>46</td><td>44</td><td></td><td>42</td><td>40</td><td>39</td><td></td><td></td><td></td><td>34</td><td>33</td></tr> <tr><td></td><td></td><td>73</td><td></td><td></td><td>32</td><td>30</td><td></td><td></td><td>26</td><td>25</td><td></td><td>22</td><td>21</td><td></td><td></td><td></td></tr> <tr><td></td><td></td><td></td><td></td><td></td><td>15</td><td>14</td><td></td><td></td><td>10</td><td>9</td><td></td><td>6</td><td>5</td><td>4</td><td></td><td></td></tr> </table>	72	70				66		63	62		59	57			53	52	51				46	44		42	40	39				34	33			73			32	30			26	25		22	21									15	14			10	9		6	5	4				
72	70				66		63	62		59	57			53																																																												
52	51				46	44		42	40	39				34	33																																																											
		73			32	30			26	25		22	21																																																													
					15	14			10	9		6	5	4																																																												

ENTER DESCRIPTION EC NO: UAU2016-0232 DRAWN BY: 2015/08/14 CHKD: 2015/08/14 APPR: WJOSH REV: G34	QUALITY SYMBOLS ∇=0 ∇=0 ∇=0	GENERAL TOLERANCES (UNLESS SPECIFIED) mm INCH 4 PLACES ±--- ±--- 3 PLACES ±--- ±--- 2 PLACES ±--- ±--- 1 PLACE ±--- ±--- 0 PLACE ±--- ±---	DIMENSION STYLE MM ONLY	SCALE METRIC	DESIGN UNITS METRIC	THIRD ANGLE PROJECTION
	DRAWN BY: SKRAJENDRANA 2011/02/14 CHECKED BY: MYANSLAMBROU 2011/02/14 APPROVED BY:		DATE:		TITLE: MX123 66/73/80CKT HRNS CONN ASSY	
	MATERIAL NO. SEE BOM TABLE		DOCUMENT NO. SD-34566-001		SHEET NO. 38 OF 85	
	THIS DRAWING CONTAINS INFORMATION THAT IS PROPRIETARY TO MOLEX INCORPORATED AND SHOULD NOT BE USED WITHOUT WRITTEN PERMISSION					

STATUS	GM PART #	MATERIAL #	PART/MATERIAL REVISION	WIRE DRESS OPTION	KEY OPTION	COLOR (TPA)	NUMBERS INDICATE CAVITIES OPEN FOR CIRCUITS																																																																								
AVAILABLE	NOT APPLICABLE	34566-3253	G	0	A	BLACK	<table border="1"> <tr><td></td><td>70</td><td>69</td><td></td><td></td><td></td><td>63</td><td></td><td></td><td></td><td>58</td><td>56</td><td>55</td><td>54</td><td>53</td></tr> <tr><td>52</td><td>51</td><td>49</td><td></td><td></td><td></td><td>44</td><td>43</td><td>42</td><td>41</td><td></td><td></td><td>36</td><td>34</td><td></td></tr> <tr><td></td><td></td><td>73</td><td>32</td><td></td><td></td><td>28</td><td>26</td><td></td><td></td><td></td><td></td><td></td><td>19</td><td>18</td></tr> <tr><td></td><td></td><td></td><td>16</td><td>15</td><td></td><td>12</td><td>10</td><td></td><td></td><td></td><td></td><td></td><td>3</td><td></td></tr> </table>		70	69				63				58	56	55	54	53	52	51	49				44	43	42	41			36	34				73	32			28	26						19	18				16	15		12	10						3													
	70	69				63				58	56	55	54	53																																																																	
52	51	49				44	43	42	41			36	34																																																																		
		73	32			28	26						19	18																																																																	
			16	15		12	10						3																																																																		
AVAILABLE	NOT APPLICABLE	34566-3263	G	0	C	BLUE	<table border="1"> <tr><td>72</td><td>70</td><td></td><td></td><td>66</td><td></td><td>63</td><td>62</td><td></td><td></td><td>59</td><td>57</td><td>56</td><td>55</td><td>53</td></tr> <tr><td>52</td><td>51</td><td></td><td></td><td>46</td><td>44</td><td>42</td><td>40</td><td>39</td><td></td><td></td><td></td><td></td><td>34</td><td>33</td></tr> <tr><td></td><td></td><td>73</td><td>32</td><td>30</td><td></td><td>26</td><td>25</td><td></td><td></td><td>22</td><td>21</td><td>19</td><td>18</td><td></td></tr> <tr><td></td><td></td><td></td><td>15</td><td>14</td><td></td><td>10</td><td>9</td><td></td><td></td><td>6</td><td>5</td><td>4</td><td>3</td><td></td></tr> </table>	72	70			66		63	62			59	57	56	55	53	52	51			46	44	42	40	39					34	33			73	32	30		26	25			22	21	19	18					15	14		10	9			6	5	4	3													
72	70			66		63	62			59	57	56	55	53																																																																	
52	51			46	44	42	40	39					34	33																																																																	
		73	32	30		26	25			22	21	19	18																																																																		
			15	14		10	9			6	5	4	3																																																																		
AVAILABLE	NOT APPLICABLE	34566-3273	G	0	A	BLACK	<table border="1"> <tr><td></td><td>70</td><td>69</td><td></td><td></td><td></td><td>63</td><td></td><td></td><td></td><td>58</td><td>56</td><td>55</td><td>54</td><td>53</td></tr> <tr><td>52</td><td>51</td><td>49</td><td></td><td></td><td></td><td>44</td><td>43</td><td>42</td><td>41</td><td></td><td></td><td>36</td><td>34</td><td></td></tr> <tr><td></td><td></td><td>73</td><td>32</td><td></td><td></td><td>28</td><td>26</td><td></td><td></td><td></td><td></td><td>19</td><td>18</td><td>17</td></tr> <tr><td></td><td></td><td></td><td>16</td><td>15</td><td></td><td>12</td><td>10</td><td></td><td></td><td></td><td></td><td>3</td><td>2</td><td>1</td></tr> </table>		70	69				63				58	56	55	54	53	52	51	49				44	43	42	41			36	34				73	32			28	26					19	18	17				16	15		12	10					3	2	1												
	70	69				63				58	56	55	54	53																																																																	
52	51	49				44	43	42	41			36	34																																																																		
		73	32			28	26					19	18	17																																																																	
			16	15		12	10					3	2	1																																																																	
AVAILABLE	NOT APPLICABLE	34566-3283	G	0	C	BLUE	<table border="1"> <tr><td>72</td><td>70</td><td></td><td>67</td><td>66</td><td></td><td>63</td><td>62</td><td></td><td></td><td>59</td><td>57</td><td></td><td></td><td>53</td></tr> <tr><td>52</td><td>51</td><td></td><td></td><td>46</td><td>44</td><td>42</td><td>40</td><td>39</td><td></td><td></td><td></td><td></td><td>34</td><td>33</td></tr> <tr><td></td><td></td><td>73</td><td></td><td>30</td><td></td><td>26</td><td>25</td><td></td><td></td><td>22</td><td>21</td><td></td><td></td><td></td></tr> <tr><td></td><td></td><td></td><td>15</td><td>14</td><td></td><td>10</td><td>9</td><td></td><td></td><td>6</td><td>5</td><td>4</td><td></td><td></td></tr> </table>	72	70		67	66		63	62			59	57			53	52	51			46	44	42	40	39					34	33			73		30		26	25			22	21							15	14		10	9			6	5	4														
72	70		67	66		63	62			59	57			53																																																																	
52	51			46	44	42	40	39					34	33																																																																	
		73		30		26	25			22	21																																																																				
			15	14		10	9			6	5	4																																																																			
AVAILABLE	NOT APPLICABLE	34566-3293	G	0	B	ST GRAY	<table border="1"> <tr><td>72</td><td>71</td><td>70</td><td>68</td><td>67</td><td>66</td><td></td><td></td><td>62</td><td>61</td><td>60</td><td>59</td><td>58</td><td>57</td><td>56</td><td>55</td><td>54</td><td>53</td></tr> <tr><td>52</td><td>51</td><td>50</td><td>48</td><td>47</td><td></td><td></td><td></td><td>42</td><td>41</td><td>40</td><td>39</td><td>38</td><td>37</td><td>36</td><td>35</td><td>34</td><td>33</td></tr> <tr><td></td><td></td><td>73</td><td>32</td><td>31</td><td>30</td><td>29</td><td>28</td><td>27</td><td>26</td><td>25</td><td>24</td><td>23</td><td></td><td></td><td></td><td></td><td></td></tr> <tr><td></td><td></td><td></td><td>16</td><td>15</td><td>14</td><td>13</td><td></td><td></td><td>10</td><td>9</td><td>8</td><td></td><td></td><td></td><td></td><td></td><td></td></tr> </table>	72	71	70	68	67	66			62	61	60	59	58	57	56	55	54	53	52	51	50	48	47				42	41	40	39	38	37	36	35	34	33			73	32	31	30	29	28	27	26	25	24	23									16	15	14	13			10	9	8						
72	71	70	68	67	66			62	61	60	59	58	57	56	55	54	53																																																														
52	51	50	48	47				42	41	40	39	38	37	36	35	34	33																																																														
		73	32	31	30	29	28	27	26	25	24	23																																																																			
			16	15	14	13			10	9	8																																																																				
AVAILABLE	NOT APPLICABLE	34566-3313	G	0	C	BLUE	<table border="1"> <tr><td>72</td><td>70</td><td></td><td></td><td></td><td></td><td>63</td><td>62</td><td></td><td></td><td>59</td><td>57</td><td></td><td></td><td>53</td></tr> <tr><td>52</td><td>51</td><td></td><td></td><td>46</td><td>44</td><td>42</td><td>40</td><td>39</td><td></td><td></td><td></td><td></td><td>34</td><td>33</td></tr> <tr><td></td><td></td><td>73</td><td>32</td><td>30</td><td></td><td>26</td><td>25</td><td></td><td></td><td>22</td><td>21</td><td></td><td></td><td></td></tr> <tr><td></td><td></td><td></td><td>15</td><td>14</td><td></td><td></td><td></td><td></td><td></td><td>6</td><td>5</td><td>4</td><td></td><td></td></tr> </table>	72	70					63	62			59	57			53	52	51			46	44	42	40	39					34	33			73	32	30		26	25			22	21							15	14						6	5	4														
72	70					63	62			59	57			53																																																																	
52	51			46	44	42	40	39					34	33																																																																	
		73	32	30		26	25			22	21																																																																				
			15	14						6	5	4																																																																			
AVAILABLE	NOT APPLICABLE	34566-3323	G	0	B	ST GRAY	<table border="1"> <tr><td></td><td></td><td></td><td>68</td><td>67</td><td>66</td><td>65</td><td>64</td><td>63</td><td></td><td></td><td></td><td>58</td><td></td><td>55</td><td></td><td></td><td></td></tr> <tr><td></td><td></td><td>49</td><td>48</td><td>46</td><td>45</td><td>44</td><td>43</td><td></td><td></td><td></td><td></td><td>38</td><td></td><td></td><td></td><td></td><td></td></tr> <tr><td></td><td></td><td>73</td><td>32</td><td>30</td><td>29</td><td>28</td><td>27</td><td></td><td></td><td></td><td>22</td><td></td><td></td><td></td><td></td><td></td><td>17</td></tr> <tr><td></td><td></td><td></td><td>16</td><td></td><td></td><td></td><td></td><td>10</td><td></td><td></td><td></td><td></td><td></td><td></td><td></td><td></td><td></td></tr> </table>				68	67	66	65	64	63				58		55						49	48	46	45	44	43					38								73	32	30	29	28	27				22						17				16					10									
			68	67	66	65	64	63				58		55																																																																	
		49	48	46	45	44	43					38																																																																			
		73	32	30	29	28	27				22						17																																																														
			16					10																																																																							
AVAILABLE	NOT APPLICABLE	34566-3333	G	0	A	BLACK	<table border="1"> <tr><td>72</td><td>71</td><td>70</td><td>69</td><td>68</td><td></td><td>65</td><td>64</td><td>63</td><td></td><td>61</td><td>59</td><td>58</td><td>57</td><td>56</td><td></td><td>54</td><td></td></tr> <tr><td>52</td><td>51</td><td>50</td><td>49</td><td>47</td><td></td><td></td><td></td><td>42</td><td>41</td><td></td><td></td><td>38</td><td>37</td><td>36</td><td></td><td>34</td><td>33</td></tr> <tr><td></td><td></td><td>73</td><td>32</td><td>31</td><td>30</td><td>29</td><td>28</td><td>27</td><td>26</td><td></td><td>24</td><td>23</td><td></td><td></td><td>20</td><td>19</td><td>18</td></tr> <tr><td></td><td></td><td></td><td>16</td><td></td><td></td><td>13</td><td>12</td><td>11</td><td>10</td><td>9</td><td></td><td></td><td></td><td></td><td>3</td><td>2</td><td>1</td></tr> </table>	72	71	70	69	68		65	64	63		61	59	58	57	56		54		52	51	50	49	47				42	41			38	37	36		34	33			73	32	31	30	29	28	27	26		24	23			20	19	18				16			13	12	11	10	9					3	2	1
72	71	70	69	68		65	64	63		61	59	58	57	56		54																																																															
52	51	50	49	47				42	41			38	37	36		34	33																																																														
		73	32	31	30	29	28	27	26		24	23			20	19	18																																																														
			16			13	12	11	10	9					3	2	1																																																														

ENTER DESCRIPTION EEC NO: UAU2016-0232 DRAWN BY: CHKO CHECKED BY: APPR:VKOSHY DATE: 2015/08/14 REV: G34	QUALITY SYMBOLS	GENERAL TOLERANCES (UNLESS SPECIFIED)	DIMENSION STYLE	SCALE	DESIGN UNITS	THIRD ANGLE PROJECTION
	$\nabla=0$ $\nabla=0$ $\nabla=0$	4 PLACES ±--- mm INCH 3 PLACES ±--- ±--- 2 PLACES ±--- ±--- 1 PLACE ±--- ±--- 0 PLACE ±--- ±---	MM ONLY	MM ONLY	METRIC	
			DRAWN BY: SKRA JENDRANA 2011/02/14	DATE	TITLE	MX123 66/73/80CKT HRNS CONN ASSY
			CHECKED BY: MVANSLAMBROU 2011/02/14	DATE	APPROVED BY: DATE	molex MATERIAL NO. SD-34566-001 DOCUMENT NO. 39 OF 85

STATUS	GM PART #	MATERIAL #	PART / MATERIAL REVISION	WIRE DRESS OPTION	KEY OPTION	COLOR (TPA)	NUMBERS INDICATE CAVITIES OPEN FOR CIRCUITS																																																														
AVAILABLE	NOT APPLICABLE	34566-3343	G	0	A	BLACK	<table border="1"> <tr><td>72</td><td></td><td>69</td><td>67</td><td>66</td><td>65</td><td>63</td><td></td><td>60</td><td></td><td>57</td><td>56</td><td></td><td>53</td></tr> <tr><td></td><td></td><td>49</td><td>47</td><td></td><td>44</td><td>43</td><td>42</td><td>40</td><td></td><td>37</td><td>36</td><td>35</td><td>33</td></tr> <tr><td>73</td><td></td><td></td><td>31</td><td>30</td><td>29</td><td>28</td><td>26</td><td>24</td><td></td><td>21</td><td>20</td><td></td><td>17</td></tr> <tr><td></td><td></td><td>16</td><td>15</td><td>14</td><td>13</td><td></td><td>11</td><td>10</td><td></td><td></td><td>5</td><td>4</td><td>3</td><td>2</td><td>1</td></tr> </table>	72		69	67	66	65	63		60		57	56		53			49	47		44	43	42	40		37	36	35	33	73			31	30	29	28	26	24		21	20		17			16	15	14	13		11	10			5	4	3	2	1				
72		69	67	66	65	63		60		57	56		53																																																								
		49	47		44	43	42	40		37	36	35	33																																																								
73			31	30	29	28	26	24		21	20		17																																																								
		16	15	14	13		11	10			5	4	3	2	1																																																						
AVAILABLE	NOT APPLICABLE	34566-3353	G	0	B	ST GRAY	<table border="1"> <tr><td></td><td></td><td>68</td><td>67</td><td></td><td>64</td><td></td><td></td><td></td><td>59</td><td>58</td><td></td><td></td><td>54</td></tr> <tr><td></td><td></td><td></td><td>46</td><td>45</td><td></td><td></td><td></td><td></td><td>39</td><td>38</td><td></td><td></td><td></td></tr> <tr><td>73</td><td></td><td>32</td><td>30</td><td>29</td><td>28</td><td>27</td><td></td><td></td><td>23</td><td>22</td><td></td><td></td><td>17</td></tr> <tr><td></td><td></td><td></td><td></td><td></td><td>12</td><td>10</td><td></td><td>8</td><td></td><td></td><td></td><td></td><td></td><td></td><td>1</td></tr> </table>			68	67		64				59	58			54				46	45					39	38				73		32	30	29	28	27			23	22			17						12	10		8							1				
		68	67		64				59	58			54																																																								
			46	45					39	38																																																											
73		32	30	29	28	27			23	22			17																																																								
					12	10		8							1																																																						
AVAILABLE	NOT APPLICABLE	34566-3363	G	0	A	BLACK	<table border="1"> <tr><td></td><td>71</td><td>69</td><td>68</td><td></td><td>65</td><td>64</td><td>63</td><td>61</td><td>59</td><td>57</td><td>56</td><td></td><td>54</td></tr> <tr><td>52</td><td>50</td><td>49</td><td>47</td><td></td><td></td><td></td><td>42</td><td>41</td><td>40</td><td>39</td><td>38</td><td>37</td><td>36</td><td>34</td><td>33</td></tr> <tr><td>73</td><td></td><td></td><td>32</td><td>31</td><td>30</td><td>29</td><td>28</td><td>27</td><td>26</td><td>24</td><td>23</td><td>22</td><td>20</td><td>19</td><td>18</td></tr> <tr><td></td><td></td><td></td><td>16</td><td></td><td></td><td>13</td><td>12</td><td>11</td><td>10</td><td>9</td><td></td><td></td><td></td><td></td><td>1</td></tr> </table>		71	69	68		65	64	63	61	59	57	56		54	52	50	49	47				42	41	40	39	38	37	36	34	33	73			32	31	30	29	28	27	26	24	23	22	20	19	18				16			13	12	11	10	9					1
	71	69	68		65	64	63	61	59	57	56		54																																																								
52	50	49	47				42	41	40	39	38	37	36	34	33																																																						
73			32	31	30	29	28	27	26	24	23	22	20	19	18																																																						
			16			13	12	11	10	9					1																																																						
AVAILABLE	NOT APPLICABLE	34566-3373	G	9	C	BLUE	<table border="1"> <tr><td>72</td><td>70</td><td>68</td><td>67</td><td>66</td><td></td><td>63</td><td>62</td><td></td><td>59</td><td>57</td><td>56</td><td>55</td><td>53</td></tr> <tr><td>52</td><td>51</td><td></td><td>48</td><td>47</td><td>46</td><td>44</td><td>42</td><td>40</td><td>39</td><td>38</td><td></td><td></td><td>34</td><td>33</td></tr> <tr><td>73</td><td></td><td></td><td>32</td><td>30</td><td></td><td></td><td>26</td><td>25</td><td></td><td>22</td><td>21</td><td></td><td>19</td><td>18</td></tr> <tr><td></td><td></td><td></td><td>15</td><td>14</td><td></td><td></td><td>10</td><td>9</td><td></td><td>6</td><td>5</td><td>4</td><td>3</td><td></td><td></td></tr> </table>	72	70	68	67	66		63	62		59	57	56	55	53	52	51		48	47	46	44	42	40	39	38			34	33	73			32	30			26	25		22	21		19	18				15	14			10	9		6	5	4	3				
72	70	68	67	66		63	62		59	57	56	55	53																																																								
52	51		48	47	46	44	42	40	39	38			34	33																																																							
73			32	30			26	25		22	21		19	18																																																							
			15	14			10	9		6	5	4	3																																																								
AVAILABLE	NOT APPLICABLE	34566-3383	G	0	A	BLACK	<table border="1"> <tr><td></td><td>70</td><td>69</td><td>68</td><td></td><td>65</td><td>64</td><td>63</td><td>61</td><td>59</td><td>58</td><td>57</td><td>56</td><td>54</td></tr> <tr><td>52</td><td>50</td><td>49</td><td>48</td><td>47</td><td></td><td></td><td>42</td><td>41</td><td></td><td>38</td><td>37</td><td>36</td><td>34</td><td>33</td></tr> <tr><td>73</td><td></td><td></td><td>32</td><td>31</td><td>30</td><td>29</td><td>28</td><td>27</td><td>26</td><td>24</td><td>23</td><td></td><td>20</td><td>19</td><td>18</td></tr> <tr><td></td><td></td><td></td><td>16</td><td></td><td></td><td>13</td><td>12</td><td>11</td><td>10</td><td>9</td><td></td><td></td><td></td><td></td><td>1</td></tr> </table>		70	69	68		65	64	63	61	59	58	57	56	54	52	50	49	48	47			42	41		38	37	36	34	33	73			32	31	30	29	28	27	26	24	23		20	19	18				16			13	12	11	10	9					1	
	70	69	68		65	64	63	61	59	58	57	56	54																																																								
52	50	49	48	47			42	41		38	37	36	34	33																																																							
73			32	31	30	29	28	27	26	24	23		20	19	18																																																						
			16			13	12	11	10	9					1																																																						
AVAILABLE	NOT APPLICABLE	34566-3393	G	0	C	BLUE	<table border="1"> <tr><td>72</td><td>70</td><td>68</td><td>67</td><td>66</td><td></td><td>63</td><td>62</td><td></td><td>59</td><td>57</td><td></td><td></td><td>53</td></tr> <tr><td>52</td><td>51</td><td></td><td>48</td><td>47</td><td>46</td><td>44</td><td>42</td><td>40</td><td>39</td><td></td><td></td><td></td><td>34</td><td>33</td></tr> <tr><td>73</td><td></td><td></td><td>32</td><td>30</td><td></td><td></td><td>26</td><td>25</td><td></td><td>22</td><td>21</td><td></td><td></td><td></td></tr> <tr><td></td><td></td><td></td><td>15</td><td>14</td><td></td><td></td><td>10</td><td>9</td><td></td><td>6</td><td>5</td><td>4</td><td></td><td></td><td></td></tr> </table>	72	70	68	67	66		63	62		59	57			53	52	51		48	47	46	44	42	40	39				34	33	73			32	30			26	25		22	21							15	14			10	9		6	5	4					
72	70	68	67	66		63	62		59	57			53																																																								
52	51		48	47	46	44	42	40	39				34	33																																																							
73			32	30			26	25		22	21																																																										
			15	14			10	9		6	5	4																																																									
AVAILABLE	NOT APPLICABLE	34566-3413	G	0	A	BLACK	<table border="1"> <tr><td>72</td><td>70</td><td></td><td>67</td><td>66</td><td>65</td><td></td><td></td><td>61</td><td></td><td>58</td><td>57</td><td>55</td><td>54</td></tr> <tr><td></td><td>50</td><td>49</td><td>47</td><td>45</td><td>44</td><td>43</td><td>42</td><td>41</td><td>39</td><td>37</td><td>35</td><td></td><td></td></tr> <tr><td>73</td><td></td><td></td><td>32</td><td>30</td><td></td><td>27</td><td>26</td><td>25</td><td>24</td><td>21</td><td>20</td><td>19</td><td>18</td><td>17</td></tr> <tr><td></td><td></td><td></td><td>16</td><td>15</td><td>13</td><td>11</td><td>10</td><td>9</td><td>8</td><td>6</td><td>5</td><td>3</td><td>2</td><td>1</td></tr> </table>	72	70		67	66	65			61		58	57	55	54		50	49	47	45	44	43	42	41	39	37	35			73			32	30		27	26	25	24	21	20	19	18	17				16	15	13	11	10	9	8	6	5	3	2	1				
72	70		67	66	65			61		58	57	55	54																																																								
	50	49	47	45	44	43	42	41	39	37	35																																																										
73			32	30		27	26	25	24	21	20	19	18	17																																																							
			16	15	13	11	10	9	8	6	5	3	2	1																																																							
AVAILABLE	NOT APPLICABLE	34566-3423	G	9	C	BLUE	<table border="1"> <tr><td></td><td></td><td>69</td><td></td><td></td><td></td><td>63</td><td></td><td></td><td></td><td>58</td><td>56</td><td>55</td><td>54</td><td>53</td></tr> <tr><td>52</td><td>51</td><td>49</td><td></td><td></td><td>44</td><td>43</td><td>42</td><td>41</td><td></td><td></td><td>36</td><td>35</td><td>34</td><td>33</td></tr> <tr><td>73</td><td></td><td></td><td></td><td></td><td>28</td><td>26</td><td></td><td></td><td></td><td></td><td></td><td>19</td><td>18</td><td>17</td></tr> <tr><td></td><td></td><td></td><td></td><td></td><td>12</td><td>10</td><td></td><td></td><td></td><td></td><td></td><td></td><td>3</td><td>2</td><td>1</td></tr> </table>			69				63				58	56	55	54	53	52	51	49			44	43	42	41			36	35	34	33	73					28	26						19	18	17						12	10							3	2	1	
		69				63				58	56	55	54	53																																																							
52	51	49			44	43	42	41			36	35	34	33																																																							
73					28	26						19	18	17																																																							
					12	10							3	2	1																																																						

ENTER DESCRIPTION EC NO: UAU2016-0232 DRAWN BY: 2015/08/14 CHKD: APPR: WOSHY 2015/08/14 REV:	QUALITY SYMBOLS	GENERAL TOLERANCES (UNLESS SPECIFIED)	DIMENSION STYLE	SCALE	DESIGN UNITS	THIRD ANGLE PROJECTION	
	∇=0 ∇=0 ∇=0	4 PLACES ± --- + --- 3 PLACES ± --- + --- 2 PLACES ± --- + --- 1 PLACE ± --- + --- 0 PLACE ± --- + ---	mm INCH	MM ONLY		METRIC	
	DRAWN BY: SKRAJENDRANA 2011/02/14 CHECKED BY: MYANSLAMBROU 2011/02/14 APPROVED BY:	DATE:	DATE:	DATE:	DATE:	DATE:	DATE:
	MATERIAL NO. SEE BOM TABLE DOCUMENT NO. SD-34566-001	SHEET NO. 40 OF 85	TITLE: MX123 66/73/80CKT HRNS CONN ASSY molex				

STATUS	GM PART #	MATERIAL #	PART/MATERIAL REVISION	WIRE DRESS OPTION	KEY OPTION	COLOR (TPA)	NUMBERS INDICATE CAVITIES OPEN FOR CIRCUITS																																																																																
AVAILABLE	NOT APPLICABLE	34566-3433	G	9	C	BLUE	<table border="1"> <tr><td>72</td><td>70</td><td></td><td></td><td>66</td><td></td><td>63</td><td>62</td><td></td><td></td><td>59</td><td></td><td>57</td><td>56</td><td>55</td><td>53</td></tr> <tr><td>52</td><td>51</td><td></td><td></td><td>46</td><td></td><td>44</td><td>42</td><td></td><td>40</td><td>39</td><td></td><td>22</td><td>21</td><td></td><td>34</td><td>33</td></tr> <tr><td></td><td></td><td>73</td><td></td><td>30</td><td></td><td></td><td>26</td><td>25</td><td></td><td></td><td></td><td></td><td></td><td></td><td></td><td></td></tr> <tr><td></td><td></td><td></td><td></td><td>15</td><td>14</td><td></td><td></td><td>10</td><td>9</td><td></td><td></td><td>6</td><td></td><td></td><td></td><td></td></tr> </table>	72	70			66		63	62			59		57	56	55	53	52	51			46		44	42		40	39		22	21		34	33			73		30			26	25													15	14			10	9			6																	
72	70			66		63	62			59		57	56	55	53																																																																								
52	51			46		44	42		40	39		22	21		34	33																																																																							
		73		30			26	25																																																																															
				15	14			10	9			6																																																																											
AVAILABLE	NOT APPLICABLE	34566-3443	G	0	A	BLACK	<table border="1"> <tr><td></td><td>71</td><td>69</td><td></td><td></td><td></td><td>65</td><td>64</td><td>63</td><td></td><td>60</td><td></td><td></td><td>57</td><td>56</td><td>55</td><td>54</td><td>53</td></tr> <tr><td>52</td><td>51</td><td>49</td><td></td><td></td><td></td><td>45</td><td>44</td><td>43</td><td>42</td><td>41</td><td></td><td></td><td>37</td><td>36</td><td>35</td><td>34</td><td>33</td></tr> <tr><td></td><td></td><td></td><td>73</td><td></td><td>32</td><td>30</td><td>28</td><td>26</td><td></td><td></td><td>23</td><td></td><td></td><td></td><td>19</td><td>18</td><td></td></tr> <tr><td></td><td></td><td></td><td></td><td></td><td>16</td><td></td><td></td><td>12</td><td>10</td><td></td><td></td><td></td><td></td><td></td><td>3</td><td></td><td></td></tr> </table>		71	69				65	64	63		60			57	56	55	54	53	52	51	49				45	44	43	42	41			37	36	35	34	33				73		32	30	28	26			23				19	18							16			12	10						3										
	71	69				65	64	63		60			57	56	55	54	53																																																																						
52	51	49				45	44	43	42	41			37	36	35	34	33																																																																						
			73		32	30	28	26			23				19	18																																																																							
					16			12	10						3																																																																								
AVAILABLE	NOT APPLICABLE	34566-3453	G	0	A	BLACK	<table border="1"> <tr><td></td><td></td><td></td><td></td><td></td><td></td><td></td><td></td><td></td><td></td><td>61</td><td></td><td></td><td></td><td></td><td></td><td></td><td></td></tr> <tr><td></td><td></td><td></td><td></td><td></td><td></td><td></td><td></td><td></td><td></td><td></td><td></td><td></td><td></td><td></td><td></td><td>20</td><td></td></tr> <tr><td></td><td></td><td></td><td>73</td><td></td><td></td><td></td><td></td><td></td><td></td><td></td><td>9</td><td></td><td></td><td>5</td><td></td><td></td><td>1</td></tr> </table>											61																								20					73								9			5			1																										
										61																																																																													
																20																																																																							
			73								9			5			1																																																																						
AVAILABLE	NOT APPLICABLE	34566-3463	G	9	H	ST GRY	<table border="1"> <tr><td></td><td></td><td></td><td></td><td></td><td></td><td></td><td></td><td></td><td></td><td></td><td></td><td></td><td></td><td></td><td></td><td></td><td>61</td></tr> <tr><td></td><td></td><td></td><td></td><td></td><td></td><td></td><td></td><td></td><td></td><td></td><td></td><td></td><td></td><td></td><td></td><td></td><td></td></tr> <tr><td>20</td><td></td><td></td><td></td><td></td><td></td><td></td><td></td><td></td><td></td><td></td><td>9</td><td></td><td></td><td>5</td><td></td><td></td><td>1</td></tr> </table>																		61																			20											9			5			1																										
																	61																																																																						
20											9			5			1																																																																						
AVAILABLE	NOT APPLICABLE	34566-3473	G	9	B	ST GRY	<table border="1"> <tr><td>72</td><td>71</td><td>69</td><td>68</td><td>67</td><td>66</td><td>65</td><td>64</td><td></td><td>62</td><td>61</td><td>60</td><td>59</td><td>58</td><td>57</td><td>56</td><td>55</td><td>54</td></tr> <tr><td>52</td><td>51</td><td>50</td><td>49</td><td></td><td>46</td><td>44</td><td></td><td></td><td></td><td></td><td>40</td><td>38</td><td>37</td><td>36</td><td></td><td></td><td></td></tr> <tr><td></td><td></td><td></td><td></td><td>73</td><td></td><td>32</td><td>31</td><td>30</td><td>29</td><td>28</td><td>27</td><td>25</td><td>24</td><td></td><td>21</td><td>20</td><td>18</td><td>17</td></tr> <tr><td></td><td></td><td></td><td></td><td></td><td></td><td>16</td><td>15</td><td>14</td><td>13</td><td>12</td><td>10</td><td>9</td><td>7</td><td>6</td><td>5</td><td>4</td><td>3</td><td>2</td></tr> </table>	72	71	69	68	67	66	65	64		62	61	60	59	58	57	56	55	54	52	51	50	49		46	44					40	38	37	36								73		32	31	30	29	28	27	25	24		21	20	18	17							16	15	14	13	12	10	9	7	6	5	4	3	2						
72	71	69	68	67	66	65	64		62	61	60	59	58	57	56	55	54																																																																						
52	51	50	49		46	44					40	38	37	36																																																																									
				73		32	31	30	29	28	27	25	24		21	20	18	17																																																																					
						16	15	14	13	12	10	9	7	6	5	4	3	2																																																																					
AVAILABLE	NOT APPLICABLE	34566-3483	G	0	B	ST GRY	<table border="1"> <tr><td>72</td><td>71</td><td>70</td><td>69</td><td>68</td><td>67</td><td>66</td><td>65</td><td></td><td></td><td>61</td><td>60</td><td></td><td></td><td>57</td><td>56</td><td>55</td><td>54</td></tr> <tr><td>52</td><td>51</td><td>50</td><td>49</td><td>48</td><td>46</td><td>44</td><td></td><td></td><td></td><td></td><td>40</td><td>38</td><td>37</td><td>36</td><td></td><td></td><td></td></tr> <tr><td></td><td></td><td></td><td></td><td></td><td></td><td></td><td></td><td></td><td></td><td></td><td>24</td><td></td><td></td><td>21</td><td>20</td><td>19</td><td>18</td><td>17</td></tr> <tr><td></td><td></td><td></td><td></td><td></td><td></td><td></td><td></td><td></td><td></td><td></td><td></td><td>7</td><td>6</td><td>5</td><td>4</td><td>2</td><td></td><td></td></tr> </table>	72	71	70	69	68	67	66	65			61	60			57	56	55	54	52	51	50	49	48	46	44					40	38	37	36															24			21	20	19	18	17													7	6	5	4	2								
72	71	70	69	68	67	66	65			61	60			57	56	55	54																																																																						
52	51	50	49	48	46	44					40	38	37	36																																																																									
											24			21	20	19	18	17																																																																					
												7	6	5	4	2																																																																							
AVAILABLE	NOT APPLICABLE	34566-3493	G	0	A	BLACK	<table border="1"> <tr><td>72</td><td>70</td><td></td><td></td><td>67</td><td>66</td><td>65</td><td></td><td></td><td></td><td>61</td><td></td><td></td><td>58</td><td>57</td><td></td><td>55</td><td>54</td></tr> <tr><td></td><td></td><td>49</td><td></td><td>47</td><td>45</td><td>44</td><td>43</td><td>42</td><td>41</td><td></td><td>39</td><td></td><td>37</td><td></td><td>35</td><td></td><td></td></tr> <tr><td></td><td></td><td></td><td>73</td><td></td><td>32</td><td>30</td><td></td><td>27</td><td>26</td><td>25</td><td>24</td><td></td><td></td><td>21</td><td>20</td><td>19</td><td>18</td><td>17</td></tr> <tr><td></td><td></td><td></td><td></td><td></td><td>16</td><td>15</td><td>13</td><td></td><td>11</td><td>10</td><td>9</td><td>8</td><td>6</td><td>5</td><td>3</td><td>2</td><td>1</td><td></td></tr> </table>	72	70			67	66	65				61			58	57		55	54			49		47	45	44	43	42	41		39		37		35						73		32	30		27	26	25	24			21	20	19	18	17						16	15	13		11	10	9	8	6	5	3	2	1							
72	70			67	66	65				61			58	57		55	54																																																																						
		49		47	45	44	43	42	41		39		37		35																																																																								
			73		32	30		27	26	25	24			21	20	19	18	17																																																																					
					16	15	13		11	10	9	8	6	5	3	2	1																																																																						
AVAILABLE	NOT APPLICABLE	34566-3513	G	0	A	BLACK	<table border="1"> <tr><td></td><td>70</td><td>69</td><td></td><td></td><td></td><td></td><td></td><td>63</td><td>62</td><td>61</td><td>60</td><td></td><td></td><td>58</td><td>57</td><td>56</td><td>55</td><td>54</td><td>53</td></tr> <tr><td>52</td><td>51</td><td>49</td><td></td><td></td><td></td><td></td><td></td><td>44</td><td>43</td><td>42</td><td>41</td><td></td><td></td><td></td><td></td><td>37</td><td>36</td><td>34</td><td></td></tr> <tr><td></td><td></td><td></td><td></td><td></td><td></td><td></td><td></td><td></td><td>29</td><td>28</td><td>27</td><td>26</td><td></td><td></td><td></td><td></td><td></td><td>19</td><td>18</td></tr> <tr><td></td><td></td><td></td><td></td><td></td><td></td><td></td><td></td><td></td><td>16</td><td>15</td><td>13</td><td>12</td><td>11</td><td>10</td><td></td><td></td><td></td><td>3</td><td></td></tr> </table>		70	69						63	62	61	60			58	57	56	55	54	53	52	51	49						44	43	42	41					37	36	34											29	28	27	26						19	18										16	15	13	12	11	10				3	
	70	69						63	62	61	60			58	57	56	55	54	53																																																																				
52	51	49						44	43	42	41					37	36	34																																																																					
									29	28	27	26						19	18																																																																				
									16	15	13	12	11	10				3																																																																					

ENTER DESCRIPTION EEC NO: UAU2016-0232 DRAWN BY: 2015/08/14 CHKD: APPR: IKOSHY 2015/08/14 REV:	QUALITY SYMBOLS	GENERAL TOLERANCES (UNLESS SPECIFIED)	DIMENSION STYLE	SCALE	DESIGN UNITS	THIRD ANGLE PROJECTION
	▽=0	mm INCH	MM ONLY		METRIC	
	▽=0	4 PLACES #---#	DRAWN BY: SKRAJENDRANA 2011/02/14	DATE	TITLE	
	▽=0	3 PLACES #---#	CHECKED BY: MVANSLAMBROU 2011/02/14	DATE		
	2 PLACES #---#	APPROVED BY: DATE				
	1 PLACE #---#					
	0 PLACE #---#					
	ANGULAR ±---°	DRAFT WHERE APPLICABLE MUST REMAIN WITHIN DIMENSIONS	SEE BOM TABLE	MATERIAL NO.	DOCUMENT NO.	SHEET NO.

MX123
66/73/80CKT
HRNS CONN ASSY



SD-34566-001

THIS DRAWING CONTAINS INFORMATION THAT IS PROPRIETARY TO MOLEX INCORPORATED AND SHOULD NOT BE USED WITHOUT WRITTEN PERMISSION

STATUS	GM PART #	MATERIAL #	PART/MATERIAL REVISION	WIRE DRESS OPTION	KEY OPTION	COLOR (TPA)	NUMBERS INDICATE CAVITIES OPEN FOR CIRCUITS																																																																																					
SALEABLE	NOT APPLICABLE	34566-3523	G	0	A	BLACK	<table border="1"> <tr><td>72</td><td>70</td><td></td><td></td><td>66</td><td></td><td>63</td><td>62</td><td></td><td></td><td></td><td></td><td></td><td></td><td>56</td><td>55</td><td>54</td></tr> <tr><td>52</td><td></td><td>49</td><td></td><td></td><td></td><td>43</td><td>42</td><td></td><td></td><td></td><td></td><td></td><td></td><td>36</td><td>35</td><td>34</td></tr> <tr><td></td><td></td><td></td><td></td><td>31</td><td></td><td>28</td><td>26</td><td></td><td></td><td></td><td></td><td></td><td></td><td>21</td><td>20</td><td>19</td></tr> <tr><td>73</td><td></td><td>16</td><td>15</td><td></td><td>12</td><td>10</td><td>9</td><td></td><td></td><td></td><td></td><td></td><td>5</td><td></td><td></td><td>2</td></tr> <tr><td></td><td></td><td></td><td></td><td></td><td></td><td></td><td></td><td></td><td></td><td></td><td></td><td></td><td></td><td></td><td></td><td>1</td></tr> </table>	72	70			66		63	62							56	55	54	52		49				43	42							36	35	34					31		28	26							21	20	19	73		16	15		12	10	9						5			2																	1
72	70			66		63	62							56	55	54																																																																												
52		49				43	42							36	35	34																																																																												
				31		28	26							21	20	19																																																																												
73		16	15		12	10	9						5			2																																																																												
																1																																																																												
SALEABLE	NOT APPLICABLE	34566-3533	G	9	A	BLACK	<table border="1"> <tr><td></td><td></td><td>69</td><td></td><td></td><td></td><td>63</td><td></td><td></td><td></td><td></td><td></td><td></td><td>58</td><td>56</td><td>55</td><td>54</td><td>53</td></tr> <tr><td>52</td><td>51</td><td>49</td><td></td><td></td><td></td><td>44</td><td>43</td><td>42</td><td>41</td><td></td><td></td><td></td><td></td><td>36</td><td>35</td><td>34</td><td>33</td></tr> <tr><td></td><td></td><td></td><td></td><td>32</td><td></td><td>28</td><td>26</td><td></td><td></td><td></td><td></td><td></td><td></td><td></td><td>19</td><td>18</td><td>17</td></tr> <tr><td>73</td><td></td><td>16</td><td></td><td></td><td>12</td><td>10</td><td></td><td></td><td></td><td></td><td></td><td></td><td></td><td></td><td>3</td><td>2</td><td>1</td></tr> </table>			69				63							58	56	55	54	53	52	51	49				44	43	42	41					36	35	34	33					32		28	26								19	18	17	73		16			12	10									3	2	1													
		69				63							58	56	55	54	53																																																																											
52	51	49				44	43	42	41					36	35	34	33																																																																											
				32		28	26								19	18	17																																																																											
73		16			12	10									3	2	1																																																																											
AVAILABLE	NOT APPLICABLE	34566-3543	G	9	A	BLACK	<table border="1"> <tr><td>72</td><td>70</td><td></td><td></td><td>66</td><td></td><td>63</td><td>62</td><td></td><td></td><td></td><td></td><td></td><td>59</td><td>57</td><td>56</td><td>55</td><td>53</td></tr> <tr><td>52</td><td>51</td><td></td><td></td><td>46</td><td>44</td><td>42</td><td>41</td><td></td><td></td><td></td><td></td><td></td><td>40</td><td>39</td><td></td><td></td><td>34</td><td>33</td></tr> <tr><td></td><td></td><td></td><td></td><td>30</td><td></td><td>26</td><td>25</td><td></td><td></td><td></td><td></td><td></td><td>22</td><td>21</td><td></td><td></td><td></td><td></td></tr> <tr><td>73</td><td></td><td>15</td><td>14</td><td></td><td></td><td>10</td><td>9</td><td></td><td></td><td></td><td></td><td></td><td>6</td><td></td><td></td><td></td><td></td><td></td></tr> </table>	72	70			66		63	62						59	57	56	55	53	52	51			46	44	42	41						40	39			34	33					30		26	25						22	21					73		15	14			10	9						6															
72	70			66		63	62						59	57	56	55	53																																																																											
52	51			46	44	42	41						40	39			34	33																																																																										
				30		26	25						22	21																																																																														
73		15	14			10	9						6																																																																															
AVAILABLE	NOT APPLICABLE	34566-3553	G	9	C	BLUE	<table border="1"> <tr><td>72</td><td>71</td><td>70</td><td>69</td><td>68</td><td>67</td><td>66</td><td>65</td><td>63</td><td>62</td><td>61</td><td>59</td><td>58</td><td>57</td><td>56</td><td>55</td><td>54</td><td>53</td></tr> <tr><td>52</td><td>51</td><td>50</td><td>49</td><td>48</td><td>46</td><td>45</td><td>44</td><td>43</td><td>42</td><td>41</td><td>40</td><td>39</td><td>38</td><td>36</td><td>35</td><td>34</td><td>33</td></tr> <tr><td></td><td></td><td></td><td></td><td>31</td><td>30</td><td>29</td><td>28</td><td>27</td><td>26</td><td>25</td><td>22</td><td>20</td><td>19</td><td>18</td><td>17</td><td></td><td></td></tr> <tr><td>73</td><td></td><td>16</td><td>15</td><td>14</td><td></td><td></td><td></td><td>11</td><td>10</td><td>9</td><td>7</td><td>6</td><td>5</td><td></td><td>3</td><td>2</td><td>1</td></tr> </table>	72	71	70	69	68	67	66	65	63	62	61	59	58	57	56	55	54	53	52	51	50	49	48	46	45	44	43	42	41	40	39	38	36	35	34	33					31	30	29	28	27	26	25	22	20	19	18	17			73		16	15	14				11	10	9	7	6	5		3	2	1													
72	71	70	69	68	67	66	65	63	62	61	59	58	57	56	55	54	53																																																																											
52	51	50	49	48	46	45	44	43	42	41	40	39	38	36	35	34	33																																																																											
				31	30	29	28	27	26	25	22	20	19	18	17																																																																													
73		16	15	14				11	10	9	7	6	5		3	2	1																																																																											
AVAILABLE	NOT APPLICABLE	34566-3563	G	9	C	BLUE	<table border="1"> <tr><td>72</td><td>70</td><td>68</td><td>67</td><td>66</td><td></td><td>63</td><td>62</td><td></td><td></td><td></td><td>59</td><td>57</td><td></td><td></td><td></td><td></td><td>53</td></tr> <tr><td>52</td><td>51</td><td></td><td>48</td><td>47</td><td>46</td><td>44</td><td>42</td><td></td><td></td><td></td><td>40</td><td>39</td><td>38</td><td></td><td></td><td></td><td>34</td><td>33</td></tr> <tr><td></td><td></td><td></td><td>32</td><td></td><td>30</td><td></td><td>27</td><td>26</td><td>25</td><td></td><td></td><td></td><td>22</td><td>21</td><td></td><td></td><td></td><td></td></tr> <tr><td>73</td><td></td><td>15</td><td>14</td><td></td><td></td><td></td><td>10</td><td>9</td><td></td><td></td><td>6</td><td>5</td><td>4</td><td></td><td></td><td></td><td></td><td></td></tr> </table>	72	70	68	67	66		63	62				59	57					53	52	51		48	47	46	44	42				40	39	38				34	33				32		30		27	26	25				22	21					73		15	14				10	9			6	5	4															
72	70	68	67	66		63	62				59	57					53																																																																											
52	51		48	47	46	44	42				40	39	38				34	33																																																																										
			32		30		27	26	25				22	21																																																																														
73		15	14				10	9			6	5	4																																																																															
AVAILABLE	NOT APPLICABLE	34566-3573	G	9	C	BLUE	<table border="1"> <tr><td></td><td>70</td><td>69</td><td>68</td><td></td><td></td><td></td><td>63</td><td>62</td><td>61</td><td></td><td></td><td></td><td>58</td><td>57</td><td>56</td><td>55</td><td>54</td><td>53</td></tr> <tr><td>52</td><td>51</td><td>50</td><td>49</td><td>48</td><td>47</td><td></td><td>44</td><td>43</td><td>42</td><td>41</td><td></td><td></td><td></td><td>37</td><td>36</td><td></td><td>34</td><td></td></tr> <tr><td></td><td></td><td></td><td>32</td><td></td><td>29</td><td>28</td><td>27</td><td>26</td><td></td><td></td><td></td><td></td><td></td><td></td><td></td><td>19</td><td>18</td><td></td></tr> <tr><td>73</td><td></td><td>16</td><td>15</td><td>14</td><td>13</td><td>12</td><td>11</td><td>10</td><td></td><td></td><td></td><td></td><td></td><td></td><td></td><td>3</td><td></td><td></td></tr> </table>		70	69	68				63	62	61				58	57	56	55	54	53	52	51	50	49	48	47		44	43	42	41				37	36		34					32		29	28	27	26								19	18		73		16	15	14	13	12	11	10								3											
	70	69	68				63	62	61				58	57	56	55	54	53																																																																										
52	51	50	49	48	47		44	43	42	41				37	36		34																																																																											
			32		29	28	27	26								19	18																																																																											
73		16	15	14	13	12	11	10								3																																																																												
AVAILABLE	NOT APPLICABLE	34566-3583	G	9	A	BLACK	<table border="1"> <tr><td></td><td>70</td><td>69</td><td></td><td></td><td></td><td></td><td>63</td><td>62</td><td>61</td><td></td><td></td><td></td><td>58</td><td>57</td><td>56</td><td>55</td><td>54</td><td>53</td></tr> <tr><td>52</td><td>51</td><td>50</td><td>49</td><td></td><td></td><td></td><td>44</td><td>43</td><td>42</td><td>41</td><td></td><td></td><td></td><td>37</td><td>36</td><td></td><td>34</td><td></td></tr> <tr><td></td><td></td><td></td><td>32</td><td></td><td>29</td><td>28</td><td>27</td><td>26</td><td></td><td></td><td></td><td></td><td></td><td></td><td></td><td>19</td><td>18</td><td></td></tr> <tr><td>73</td><td></td><td>16</td><td>15</td><td>14</td><td>13</td><td>12</td><td>11</td><td>10</td><td></td><td></td><td></td><td></td><td></td><td></td><td></td><td>3</td><td></td><td></td></tr> </table>		70	69					63	62	61				58	57	56	55	54	53	52	51	50	49				44	43	42	41				37	36		34					32		29	28	27	26								19	18		73		16	15	14	13	12	11	10								3											
	70	69					63	62	61				58	57	56	55	54	53																																																																										
52	51	50	49				44	43	42	41				37	36		34																																																																											
			32		29	28	27	26								19	18																																																																											
73		16	15	14	13	12	11	10								3																																																																												
AVAILABLE	NOT APPLICABLE	34566-3593	G	0	A	BLACK	<table border="1"> <tr><td></td><td>71</td><td>69</td><td></td><td></td><td></td><td>64</td><td>63</td><td></td><td></td><td>60</td><td></td><td></td><td>58</td><td>57</td><td>56</td><td>55</td><td>54</td><td>53</td></tr> <tr><td>52</td><td>51</td><td>49</td><td></td><td></td><td></td><td>45</td><td>44</td><td>43</td><td>42</td><td>41</td><td></td><td></td><td></td><td>37</td><td>36</td><td>35</td><td>34</td><td>33</td></tr> <tr><td></td><td></td><td></td><td></td><td>32</td><td>30</td><td>28</td><td>27</td><td>26</td><td></td><td></td><td></td><td></td><td></td><td></td><td></td><td>19</td><td>18</td><td></td></tr> <tr><td>73</td><td></td><td>16</td><td>15</td><td></td><td></td><td>12</td><td>10</td><td></td><td></td><td></td><td></td><td></td><td></td><td></td><td></td><td>3</td><td></td><td></td></tr> </table>		71	69				64	63			60			58	57	56	55	54	53	52	51	49				45	44	43	42	41				37	36	35	34	33					32	30	28	27	26								19	18		73		16	15			12	10									3											
	71	69				64	63			60			58	57	56	55	54	53																																																																										
52	51	49				45	44	43	42	41				37	36	35	34	33																																																																										
				32	30	28	27	26								19	18																																																																											
73		16	15			12	10									3																																																																												
AVAILABLE	NOT APPLICABLE	34566-3613	G	0	B	ST GRY	<table border="1"> <tr><td></td><td></td><td></td><td>68</td><td>67</td><td></td><td>64</td><td>63</td><td></td><td></td><td></td><td>59</td><td></td><td></td><td></td><td></td><td></td><td></td><td></td></tr> <tr><td></td><td></td><td></td><td>46</td><td>45</td><td></td><td>43</td><td></td><td></td><td></td><td></td><td>39</td><td></td><td></td><td></td><td></td><td></td><td></td><td></td></tr> <tr><td></td><td></td><td></td><td>32</td><td>30</td><td>29</td><td>28</td><td>27</td><td></td><td></td><td></td><td></td><td></td><td></td><td></td><td></td><td></td><td></td><td></td></tr> <tr><td>73</td><td></td><td></td><td></td><td></td><td></td><td></td><td></td><td>10</td><td></td><td></td><td></td><td></td><td>6</td><td>5</td><td>4</td><td>3</td><td></td><td></td></tr> </table>				68	67		64	63				59											46	45		43					39											32	30	29	28	27												73								10					6	5	4	3											
			68	67		64	63				59																																																																																	
			46	45		43					39																																																																																	
			32	30	29	28	27																																																																																					
73								10					6	5	4	3																																																																												

ENTER DESCRIPTION EC NO: UAU2016-0232 DRAWN BY: 2015/08/14 CHKD: APPR:IKOSHY 2015/08/14 REV: DESCRIPTION	QUALITY SYMBOLS	GENERAL TOLERANCES (UNLESS SPECIFIED)	DIMENSION STYLE	SCALE	DESIGN UNITS	THIRD ANGLE PROJECTION	
	∇=0 ∇=0 ∇=0	4 PLACES ± --- INCH 3 PLACES ± --- INCH 2 PLACES ± --- INCH 1 PLACE ± --- INCH 0 PLACE ± --- INCH	mm INCH ANGULAR ± --- ° DRAFT WHERE APPLICABLE MUST REMAIN WITHIN DIMENSIONS	MM ONLY		METRIC	DRAWN BY: SKRA JENDRANA 2011/02/14 CHECKED BY: MVANSLAMBROU 2011/02/14 APPROVED BY:
							MX123 66/73/80CKT HRNS CONN ASSY molex
							MATERIAL NO. SEE BOM TABLE DOCUMENT NO. SD-34566-001 SHEET NO. 42 OF 85

STATUS	GM PART #	MATERIAL #	PART/MATERIAL REVISION	WIRE DRESS OPTION	KEY OPTION	COLOR (TPA)	NUMBERS INDICATE CAVITIES OPEN FOR CIRCUITS																																																																																															
AVAILABLE	NOT APPLICABLE	34566-3823	G	0	A	BLACK	<table border="1"> <tr><td></td><td>70</td><td>69</td><td></td><td></td><td></td><td>63</td><td>61</td><td></td><td></td><td>58</td><td>57</td><td>56</td><td>55</td><td>54</td><td>53</td></tr> <tr><td>52</td><td>51</td><td>49</td><td></td><td></td><td></td><td>44</td><td>43</td><td>41</td><td></td><td></td><td></td><td>37</td><td>36</td><td></td><td>34</td></tr> <tr><td></td><td></td><td></td><td>73</td><td>32</td><td></td><td></td><td>27</td><td>26</td><td></td><td></td><td></td><td></td><td></td><td>19</td><td>18</td></tr> <tr><td></td><td></td><td></td><td></td><td>16</td><td>15</td><td></td><td></td><td>11</td><td>10</td><td></td><td></td><td></td><td></td><td>3</td><td></td></tr> </table>		70	69				63	61			58	57	56	55	54	53	52	51	49				44	43	41				37	36		34				73	32			27	26						19	18					16	15			11	10					3																																
	70	69				63	61			58	57	56	55	54	53																																																																																							
52	51	49				44	43	41				37	36		34																																																																																							
			73	32			27	26						19	18																																																																																							
				16	15			11	10					3																																																																																								
AVAILABLE	NOT APPLICABLE	34566-3833	G	0	A	BLACK	<table border="1"> <tr><td></td><td>70</td><td>69</td><td></td><td></td><td></td><td>63</td><td>62</td><td>61</td><td></td><td></td><td></td><td>57</td><td>56</td><td>55</td><td>54</td><td>53</td></tr> <tr><td>52</td><td>51</td><td>49</td><td></td><td></td><td></td><td>44</td><td>43</td><td>42</td><td>41</td><td></td><td></td><td></td><td>37</td><td>36</td><td></td><td>34</td></tr> <tr><td></td><td></td><td></td><td>73</td><td>32</td><td></td><td>29</td><td>28</td><td>27</td><td>26</td><td></td><td></td><td>23</td><td></td><td></td><td>19</td><td>18</td></tr> <tr><td></td><td></td><td></td><td></td><td>16</td><td>15</td><td>13</td><td>12</td><td>11</td><td>10</td><td></td><td>8</td><td></td><td></td><td></td><td>3</td><td></td></tr> </table>		70	69				63	62	61				57	56	55	54	53	52	51	49				44	43	42	41				37	36		34				73	32		29	28	27	26			23			19	18					16	15	13	12	11	10		8				3																												
	70	69				63	62	61				57	56	55	54	53																																																																																						
52	51	49				44	43	42	41				37	36		34																																																																																						
			73	32		29	28	27	26			23			19	18																																																																																						
				16	15	13	12	11	10		8				3																																																																																							
AVAILABLE	NOT APPLICABLE	34566-3843	G	0	A	BLACK	<table border="1"> <tr><td>72</td><td>71</td><td>70</td><td>69</td><td>68</td><td>67</td><td>66</td><td></td><td>64</td><td>63</td><td>62</td><td></td><td>60</td><td>59</td><td></td><td></td><td>55</td><td>54</td><td>53</td></tr> <tr><td>52</td><td></td><td></td><td>49</td><td>48</td><td></td><td></td><td></td><td>44</td><td>43</td><td>42</td><td>41</td><td>40</td><td>39</td><td></td><td></td><td></td><td>35</td><td>34</td><td>33</td></tr> <tr><td></td><td></td><td></td><td></td><td></td><td></td><td></td><td>73</td><td>32</td><td></td><td>29</td><td>28</td><td>27</td><td>25</td><td>24</td><td>23</td><td></td><td></td><td>19</td><td>18</td><td>17</td></tr> <tr><td></td><td></td><td></td><td></td><td></td><td></td><td></td><td></td><td>16</td><td></td><td>13</td><td>12</td><td>11</td><td></td><td>9</td><td>8</td><td>7</td><td>6</td><td>5</td><td>4</td><td>3</td><td>2</td><td>1</td></tr> </table>	72	71	70	69	68	67	66		64	63	62		60	59			55	54	53	52			49	48				44	43	42	41	40	39				35	34	33								73	32		29	28	27	25	24	23			19	18	17									16		13	12	11		9	8	7	6	5	4	3	2	1												
72	71	70	69	68	67	66		64	63	62		60	59			55	54	53																																																																																				
52			49	48				44	43	42	41	40	39				35	34	33																																																																																			
							73	32		29	28	27	25	24	23			19	18	17																																																																																		
								16		13	12	11		9	8	7	6	5	4	3	2	1																																																																																
AVAILABLE	NOT APPLICABLE	34566-3853	G	0	A	BLACK	<table border="1"> <tr><td>72</td><td>71</td><td>70</td><td>69</td><td>68</td><td>67</td><td>66</td><td>65</td><td>64</td><td>63</td><td>62</td><td></td><td>60</td><td>59</td><td></td><td></td><td>55</td><td>54</td><td>53</td></tr> <tr><td>52</td><td></td><td></td><td>49</td><td>48</td><td></td><td></td><td></td><td>45</td><td>44</td><td>43</td><td>42</td><td>41</td><td>40</td><td>39</td><td></td><td></td><td>35</td><td>34</td><td>33</td></tr> <tr><td></td><td></td><td></td><td></td><td></td><td></td><td></td><td></td><td></td><td></td><td></td><td></td><td></td><td></td><td></td><td></td><td></td><td></td><td>19</td><td>18</td><td>17</td></tr> <tr><td></td><td></td><td></td><td></td><td></td><td></td><td></td><td></td><td></td><td></td><td></td><td></td><td></td><td></td><td></td><td></td><td></td><td></td><td></td><td></td><td></td><td></td><td></td></tr> </table>	72	71	70	69	68	67	66	65	64	63	62		60	59			55	54	53	52			49	48				45	44	43	42	41	40	39			35	34	33																			19	18	17																																			
72	71	70	69	68	67	66	65	64	63	62		60	59			55	54	53																																																																																				
52			49	48				45	44	43	42	41	40	39			35	34	33																																																																																			
																		19	18	17																																																																																		
AVAILABLE	NOT APPLICABLE	34566-3863	G	0	B	ST GRAY	<table border="1"> <tr><td>72</td><td>71</td><td>70</td><td></td><td>68</td><td>67</td><td>66</td><td></td><td></td><td></td><td>62</td><td>61</td><td>60</td><td>59</td><td>58</td><td>57</td><td>56</td><td>55</td><td>54</td><td>53</td></tr> <tr><td>52</td><td>51</td><td>50</td><td></td><td>48</td><td>47</td><td>46</td><td></td><td></td><td></td><td>42</td><td>41</td><td>40</td><td>39</td><td>38</td><td>37</td><td>36</td><td>35</td><td>34</td><td>33</td></tr> <tr><td></td><td></td><td></td><td></td><td></td><td></td><td></td><td></td><td></td><td></td><td></td><td></td><td></td><td></td><td></td><td></td><td></td><td></td><td></td><td>17</td></tr> <tr><td></td><td></td><td></td><td></td><td></td><td></td><td></td><td></td><td></td><td></td><td></td><td></td><td></td><td></td><td></td><td></td><td></td><td></td><td></td><td></td><td></td><td></td><td></td></tr> </table>	72	71	70		68	67	66				62	61	60	59	58	57	56	55	54	53	52	51	50		48	47	46				42	41	40	39	38	37	36	35	34	33																				17																																			
72	71	70		68	67	66				62	61	60	59	58	57	56	55	54	53																																																																																			
52	51	50		48	47	46				42	41	40	39	38	37	36	35	34	33																																																																																			
																			17																																																																																			
AVAILABLE	NOT APPLICABLE	34566-3873	G	0	B	ST GRAY	<table border="1"> <tr><td></td><td></td><td></td><td></td><td></td><td></td><td></td><td></td><td></td><td>63</td><td></td><td></td><td></td><td>59</td><td>58</td><td>57</td><td>56</td><td>55</td><td></td><td></td><td></td><td></td><td></td></tr> <tr><td></td><td></td><td></td><td></td><td></td><td></td><td></td><td></td><td></td><td></td><td></td><td></td><td></td><td>39</td><td>38</td><td>37</td><td>36</td><td>35</td><td>34</td><td></td><td></td><td></td><td></td></tr> <tr><td></td><td></td><td></td><td></td><td></td><td></td><td></td><td></td><td></td><td></td><td></td><td></td><td></td><td></td><td></td><td></td><td></td><td></td><td></td><td></td><td></td><td></td><td></td></tr> <tr><td></td><td></td><td></td><td></td><td></td><td></td><td></td><td></td><td></td><td></td><td></td><td></td><td></td><td></td><td></td><td></td><td></td><td></td><td></td><td></td><td></td><td></td><td></td></tr> </table>										63				59	58	57	56	55																			39	38	37	36	35	34																																																					
									63				59	58	57	56	55																																																																																					
													39	38	37	36	35	34																																																																																				
AVAILABLE	NOT APPLICABLE	34566-3883	G	0	B	ST GRAY	<table border="1"> <tr><td></td><td></td><td></td><td></td><td></td><td></td><td>67</td><td>66</td><td></td><td></td><td></td><td></td><td></td><td>59</td><td>58</td><td>57</td><td>56</td><td>55</td><td></td><td></td><td></td><td></td><td>53</td></tr> <tr><td></td><td></td><td></td><td></td><td></td><td></td><td></td><td></td><td></td><td></td><td></td><td></td><td></td><td></td><td>39</td><td>38</td><td>37</td><td>36</td><td>35</td><td>34</td><td></td><td></td><td>33</td></tr> <tr><td></td><td></td><td></td><td></td><td></td><td></td><td></td><td></td><td></td><td></td><td></td><td></td><td></td><td></td><td></td><td></td><td></td><td></td><td></td><td></td><td></td><td></td><td></td></tr> <tr><td></td><td></td><td></td><td></td><td></td><td></td><td></td><td></td><td></td><td></td><td></td><td></td><td></td><td></td><td></td><td></td><td></td><td></td><td></td><td></td><td></td><td></td><td></td></tr> </table>							67	66						59	58	57	56	55					53															39	38	37	36	35	34			33																																																	
						67	66						59	58	57	56	55					53																																																																																
														39	38	37	36	35	34			33																																																																																
AVAILABLE	NOT APPLICABLE	34566-3893	G	0	C	BLUE	<table border="1"> <tr><td>72</td><td>70</td><td></td><td>68</td><td>67</td><td>66</td><td></td><td></td><td></td><td>63</td><td>62</td><td></td><td></td><td>59</td><td></td><td>57</td><td></td><td></td><td></td><td></td><td></td><td></td><td>53</td></tr> <tr><td>52</td><td>51</td><td></td><td>48</td><td>47</td><td>46</td><td></td><td></td><td>44</td><td></td><td>42</td><td></td><td></td><td></td><td></td><td></td><td></td><td></td><td></td><td></td><td></td><td></td><td>34</td><td>33</td></tr> <tr><td></td><td></td><td></td><td></td><td></td><td></td><td></td><td></td><td></td><td></td><td></td><td></td><td></td><td></td><td></td><td></td><td></td><td></td><td></td><td></td><td></td><td></td><td></td><td></td></tr> <tr><td></td><td></td><td></td><td></td><td></td><td></td><td></td><td></td><td></td><td></td><td></td><td></td><td></td><td></td><td></td><td></td><td></td><td></td><td></td><td></td><td></td><td></td><td></td><td></td></tr> </table>	72	70		68	67	66				63	62			59		57							53	52	51		48	47	46			44		42												34	33																																																
72	70		68	67	66				63	62			59		57							53																																																																																
52	51		48	47	46			44		42												34	33																																																																															

ENTER DESCRIPTION EC NO: UAU2016-0232 DRAWN BY: 2015/08/14 CHKD: 2015/08/14 APPR: KOSHY REV: G34	QUALITY SYMBOLS ∇=0 ∇=0 ∇=0	GENERAL TOLERANCES (UNLESS SPECIFIED): mm INCH 4 PLACES ±--- ±--- 3 PLACES ±--- ±--- 2 PLACES ±--- ±--- 1 PLACE ±--- ±--- 0 PLACE ±--- ±---	DIMENSION STYLE MM ONLY	SCALE DESIGN UNITS METRIC	THIRD ANGLE PROJECTION	
	MATERIAL NO. SEE BOM TABLE	DOCUMENT NO. SD-34566-001	SHEET NO. 45 OF 85			
	DRAFT WHERE APPLICABLE MUST REMAIN WITHIN DIMENSIONS			THIS DRAWING CONTAINS INFORMATION THAT IS PROPRIETARY TO MOLEX INCORPORATED AND SHOULD NOT BE USED WITHOUT WRITTEN PERMISSION		
	TITLE MX123 66/73/80CKT HRNS CONN ASSY					

STATUS	GM PART #	MATERIAL #	PART/MATERIAL REVISION	WIRE DRESS OPTION	KEY OPTION	COLOR (TPA)	NUMBERS INDICATE CAVITIES OPEN FOR CIRCUITS																																																																				
AVAILABLE	NOT APPLICABLE	34566-3913	G	0	A	BLACK	<table border="1"> <tr><td>71</td><td>70</td><td>69</td><td></td><td></td><td></td><td>64</td><td>63</td><td></td><td>60</td><td>58</td><td>57</td><td>56</td><td>55</td><td>54</td><td>53</td></tr> <tr><td>52</td><td>51</td><td>49</td><td></td><td></td><td></td><td>45</td><td>44</td><td>43</td><td>42</td><td>41</td><td></td><td></td><td>37</td><td>36</td><td>34</td></tr> <tr><td></td><td></td><td></td><td>32</td><td>30</td><td></td><td>28</td><td>26</td><td></td><td></td><td>23</td><td></td><td></td><td>21</td><td>19</td><td>18</td></tr> <tr><td></td><td></td><td></td><td>73</td><td>16</td><td>15</td><td></td><td>12</td><td>10</td><td></td><td>8</td><td></td><td></td><td>5</td><td>3</td><td></td></tr> </table>	71	70	69				64	63		60	58	57	56	55	54	53	52	51	49				45	44	43	42	41			37	36	34				32	30		28	26			23			21	19	18				73	16	15		12	10		8			5	3					
71	70	69				64	63		60	58	57	56	55	54	53																																																												
52	51	49				45	44	43	42	41			37	36	34																																																												
			32	30		28	26			23			21	19	18																																																												
			73	16	15		12	10		8			5	3																																																													
AVAILABLE	NOT APPLICABLE	34566-3923	G	0	B	ST GRAY	<table border="1"> <tr><td>72</td><td>70</td><td>68</td><td>66</td><td></td><td></td><td></td><td></td><td></td><td>60</td><td>59</td><td></td><td></td><td>55</td><td>54</td><td>53</td></tr> <tr><td>52</td><td></td><td>50</td><td>48</td><td>46</td><td></td><td></td><td></td><td></td><td>40</td><td>39</td><td></td><td></td><td></td><td>35</td><td>34</td></tr> <tr><td></td><td></td><td></td><td>32</td><td>31</td><td>30</td><td>29</td><td>28</td><td>27</td><td>26</td><td>25</td><td>24</td><td>23</td><td></td><td>19</td><td>18</td></tr> <tr><td></td><td></td><td></td><td>73</td><td>16</td><td></td><td></td><td></td><td></td><td>10</td><td>9</td><td>8</td><td>7</td><td></td><td></td><td></td></tr> </table>	72	70	68	66						60	59			55	54	53	52		50	48	46					40	39				35	34				32	31	30	29	28	27	26	25	24	23		19	18				73	16					10	9	8	7							
72	70	68	66						60	59			55	54	53																																																												
52		50	48	46					40	39				35	34																																																												
			32	31	30	29	28	27	26	25	24	23		19	18																																																												
			73	16					10	9	8	7																																																															
AVAILABLE	NOT APPLICABLE	34566-3933	G	0	A	BLACK	<table border="1"> <tr><td>71</td><td>70</td><td>69</td><td></td><td></td><td></td><td>64</td><td>63</td><td></td><td>60</td><td>58</td><td>57</td><td>56</td><td>55</td><td>54</td><td>53</td></tr> <tr><td>52</td><td>51</td><td>49</td><td></td><td></td><td></td><td>45</td><td>44</td><td>43</td><td>42</td><td>41</td><td></td><td></td><td></td><td></td><td>34</td></tr> <tr><td></td><td></td><td></td><td>32</td><td>30</td><td></td><td>28</td><td>26</td><td></td><td></td><td></td><td></td><td></td><td></td><td>19</td><td>18</td></tr> <tr><td></td><td></td><td></td><td>73</td><td>16</td><td>15</td><td></td><td>12</td><td>10</td><td></td><td></td><td></td><td></td><td></td><td>3</td><td></td></tr> </table>	71	70	69				64	63		60	58	57	56	55	54	53	52	51	49				45	44	43	42	41					34				32	30		28	26							19	18				73	16	15		12	10						3					
71	70	69				64	63		60	58	57	56	55	54	53																																																												
52	51	49				45	44	43	42	41					34																																																												
			32	30		28	26							19	18																																																												
			73	16	15		12	10						3																																																													
AVAILABLE	NOT APPLICABLE	34566-3943	G	0	C	BLUE	<table border="1"> <tr><td>72</td><td>70</td><td>68</td><td>66</td><td></td><td></td><td></td><td></td><td></td><td>60</td><td>59</td><td></td><td></td><td>55</td><td>54</td><td>53</td></tr> <tr><td>52</td><td></td><td>50</td><td>48</td><td>46</td><td></td><td></td><td></td><td></td><td>40</td><td>39</td><td></td><td></td><td></td><td>35</td><td>34</td></tr> <tr><td></td><td></td><td></td><td>32</td><td>31</td><td>30</td><td>29</td><td>28</td><td>27</td><td>26</td><td>25</td><td>24</td><td></td><td></td><td></td><td></td></tr> <tr><td></td><td></td><td></td><td>73</td><td>16</td><td></td><td></td><td></td><td></td><td>10</td><td>9</td><td>8</td><td></td><td></td><td></td><td></td></tr> </table>	72	70	68	66						60	59			55	54	53	52		50	48	46					40	39				35	34				32	31	30	29	28	27	26	25	24								73	16					10	9	8								
72	70	68	66						60	59			55	54	53																																																												
52		50	48	46					40	39				35	34																																																												
			32	31	30	29	28	27	26	25	24																																																																
			73	16					10	9	8																																																																
AVAILABLE	NOT APPLICABLE	34566-3953	G	0	C	BLUE	<table border="1"> <tr><td>72</td><td>70</td><td>68</td><td></td><td></td><td></td><td>63</td><td>62</td><td></td><td>59</td><td>57</td><td></td><td></td><td></td><td></td><td>53</td></tr> <tr><td>52</td><td>51</td><td></td><td>48</td><td>47</td><td>46</td><td>44</td><td>42</td><td>40</td><td>39</td><td></td><td></td><td></td><td></td><td></td><td>34</td></tr> <tr><td></td><td></td><td></td><td>32</td><td>30</td><td></td><td></td><td>26</td><td>25</td><td></td><td>23</td><td>22</td><td>21</td><td>20</td><td></td><td></td></tr> <tr><td></td><td></td><td></td><td>73</td><td>15</td><td>14</td><td>13</td><td></td><td></td><td>7</td><td>6</td><td>5</td><td>4</td><td></td><td></td><td></td></tr> </table>	72	70	68				63	62		59	57					53	52	51		48	47	46	44	42	40	39						34				32	30			26	25		23	22	21	20						73	15	14	13			7	6	5	4							
72	70	68				63	62		59	57					53																																																												
52	51		48	47	46	44	42	40	39						34																																																												
			32	30			26	25		23	22	21	20																																																														
			73	15	14	13			7	6	5	4																																																															
AVAILABLE	NOT APPLICABLE	34566-3963	G	0	C	BLUE	<table border="1"> <tr><td>72</td><td>70</td><td>68</td><td>67</td><td>66</td><td></td><td>63</td><td>62</td><td></td><td>59</td><td>57</td><td></td><td></td><td></td><td></td><td>53</td></tr> <tr><td>52</td><td>51</td><td></td><td>48</td><td>47</td><td>46</td><td>44</td><td>42</td><td>40</td><td>39</td><td>38</td><td></td><td></td><td></td><td></td><td>34</td></tr> <tr><td></td><td></td><td></td><td>32</td><td>30</td><td></td><td></td><td>26</td><td>25</td><td></td><td></td><td>22</td><td>21</td><td></td><td></td><td></td></tr> <tr><td></td><td></td><td></td><td>73</td><td>15</td><td>14</td><td></td><td>10</td><td>9</td><td></td><td>6</td><td>5</td><td>4</td><td></td><td></td><td></td></tr> </table>	72	70	68	67	66		63	62		59	57					53	52	51		48	47	46	44	42	40	39	38					34				32	30			26	25			22	21							73	15	14		10	9		6	5	4							
72	70	68	67	66		63	62		59	57					53																																																												
52	51		48	47	46	44	42	40	39	38					34																																																												
			32	30			26	25			22	21																																																															
			73	15	14		10	9		6	5	4																																																															
AVAILABLE	NOT APPLICABLE	34566-3973	G	0	C	BLUE	<table border="1"> <tr><td>72</td><td>70</td><td>68</td><td>67</td><td></td><td></td><td>63</td><td>62</td><td></td><td>59</td><td>57</td><td></td><td></td><td></td><td></td><td>53</td></tr> <tr><td>52</td><td>51</td><td></td><td>48</td><td>47</td><td>46</td><td>44</td><td>42</td><td>40</td><td>39</td><td>38</td><td></td><td></td><td></td><td></td><td>34</td></tr> <tr><td></td><td></td><td></td><td>32</td><td>30</td><td></td><td></td><td>26</td><td>25</td><td></td><td></td><td>22</td><td>21</td><td></td><td></td><td></td></tr> <tr><td></td><td></td><td></td><td>73</td><td>15</td><td>14</td><td></td><td></td><td></td><td></td><td>6</td><td>5</td><td>4</td><td></td><td></td><td></td></tr> </table>	72	70	68	67			63	62		59	57					53	52	51		48	47	46	44	42	40	39	38					34				32	30			26	25			22	21							73	15	14					6	5	4							
72	70	68	67			63	62		59	57					53																																																												
52	51		48	47	46	44	42	40	39	38					34																																																												
			32	30			26	25			22	21																																																															
			73	15	14					6	5	4																																																															
AVAILABLE	NOT APPLICABLE	34566-3983	G	0	A	BLACK	<table border="1"> <tr><td>71</td><td>70</td><td>69</td><td></td><td></td><td></td><td>64</td><td>63</td><td></td><td>60</td><td>59</td><td>58</td><td>57</td><td>56</td><td>55</td><td>54</td><td>53</td></tr> <tr><td>52</td><td>51</td><td>49</td><td></td><td></td><td></td><td>45</td><td>44</td><td>43</td><td>42</td><td>41</td><td>40</td><td></td><td></td><td>37</td><td>36</td><td>34</td></tr> <tr><td></td><td></td><td></td><td>32</td><td>30</td><td></td><td>28</td><td>26</td><td></td><td></td><td></td><td></td><td></td><td></td><td>19</td><td>18</td><td></td></tr> <tr><td></td><td></td><td></td><td>73</td><td>16</td><td>15</td><td></td><td>12</td><td>10</td><td></td><td></td><td></td><td></td><td></td><td>3</td><td></td><td></td></tr> </table>	71	70	69				64	63		60	59	58	57	56	55	54	53	52	51	49				45	44	43	42	41	40			37	36	34				32	30		28	26							19	18					73	16	15		12	10						3		
71	70	69				64	63		60	59	58	57	56	55	54	53																																																											
52	51	49				45	44	43	42	41	40			37	36	34																																																											
			32	30		28	26							19	18																																																												
			73	16	15		12	10						3																																																													
AVAILABLE	NOT APPLICABLE	34566-3993	G	0	A	BLACK	<table border="1"> <tr><td></td><td>70</td><td>69</td><td></td><td></td><td></td><td>63</td><td>62</td><td>61</td><td>60</td><td>58</td><td>57</td><td>56</td><td>55</td><td>54</td><td>53</td></tr> <tr><td>52</td><td>51</td><td>49</td><td></td><td></td><td></td><td>44</td><td>43</td><td>42</td><td>41</td><td>40</td><td></td><td></td><td></td><td>37</td><td>36</td><td>34</td></tr> <tr><td></td><td></td><td></td><td>32</td><td></td><td></td><td>29</td><td>28</td><td>27</td><td>26</td><td></td><td></td><td></td><td></td><td>19</td><td>18</td><td></td></tr> <tr><td></td><td></td><td></td><td>73</td><td>16</td><td>15</td><td>13</td><td>12</td><td>11</td><td>10</td><td></td><td></td><td></td><td></td><td>3</td><td></td><td></td></tr> </table>		70	69				63	62	61	60	58	57	56	55	54	53	52	51	49				44	43	42	41	40				37	36	34				32			29	28	27	26					19	18					73	16	15	13	12	11	10					3			
	70	69				63	62	61	60	58	57	56	55	54	53																																																												
52	51	49				44	43	42	41	40				37	36	34																																																											
			32			29	28	27	26					19	18																																																												
			73	16	15	13	12	11	10					3																																																													

ENTER DESCRIPTION REC NO: VAAU2016-0232 DRAWN BY: CHKD: G34 APPR: WOSHY 2015/08/14	QUALITY SYMBOLS	GENERAL TOLERANCES (UNLESS SPECIFIED)	DIMENSION STYLE	SCALE	DESIGN UNITS	THIRD ANGLE PROJECTION	
	∇=0 ∇=0 ∇=0	4 PLACES ±---- 3 PLACES ±---- 2 PLACES ±---- 1 PLACE ±---- 0 PLACE ±----	mm INCH ±---- ±---- ±---- ±---- ±---- ±---- ±---- ±----	MM ONLY DRAWN BY: SKRA JENDRANA 2011/02/14 CHECKED BY: MVANSLAMBROU 2011/02/14 APPROVED BY:	DATE: 2015/08/14 DATE: 2011/02/14 DATE:	METRIC MX123 66/73/80CKT HRNS CONN ASSY molex	SEE BOM TABLE THIS DRAWING CONTAINS INFORMATION THAT IS PROPRIETARY TO MOLEX INCORPORATED AND SHOULD NOT BE USED WITHOUT WRITTEN PERMISSION
	ANGULAR ±---- DRAFT WHERE APPLICABLE MUST REMAIN WITHIN DIMENSIONS	MATERIAL NO. DOCUMENT NO.	SD-34566-001 46 OF 85	SHEET NO.			

STATUS	GM PART #	MATERIAL #	PART/MATERIAL REVISION	WIRE DRESS OPTION	KEY OPTION	COLOR (TPA)	NUMBERS INDICATE CAVITIES OPEN FOR CIRCUITS																																																																											
AVAILABLE	NOT APPLICABLE	34566-4013	G	0	B	ST GRY	<table border="1"> <tr><td>72</td><td>70</td><td>68</td><td>66</td><td></td><td></td><td></td><td></td><td>60</td><td>59</td><td></td><td></td><td>55</td><td>54</td><td>53</td></tr> <tr><td>52</td><td>50</td><td>48</td><td>46</td><td></td><td></td><td></td><td></td><td>40</td><td>39</td><td></td><td></td><td>35</td><td>34</td><td>33</td></tr> <tr><td colspan="2">73</td><td>32</td><td>31</td><td>30</td><td>29</td><td>28</td><td>27</td><td>26</td><td>25</td><td>24</td><td></td><td></td><td></td><td>17</td></tr> <tr><td colspan="2"></td><td>16</td><td></td><td></td><td></td><td></td><td></td><td>10</td><td>8</td><td></td><td></td><td></td><td></td><td>2</td><td>1</td></tr> </table>	72	70	68	66					60	59			55	54	53	52	50	48	46					40	39			35	34	33	73		32	31	30	29	28	27	26	25	24				17			16						10	8					2	1														
72	70	68	66					60	59			55	54	53																																																																				
52	50	48	46					40	39			35	34	33																																																																				
73		32	31	30	29	28	27	26	25	24				17																																																																				
		16						10	8					2	1																																																																			
AVAILABLE	NOT APPLICABLE	34566-4023	G	0	B	ST GRY	<table border="1"> <tr><td>72</td><td>71</td><td>70</td><td>68</td><td>67</td><td>66</td><td></td><td></td><td>62</td><td>61</td><td>60</td><td>59</td><td>58</td><td>57</td><td>56</td><td>55</td><td>54</td><td>53</td></tr> <tr><td>52</td><td>51</td><td>50</td><td>48</td><td>47</td><td>46</td><td></td><td></td><td>42</td><td>41</td><td>40</td><td>39</td><td>38</td><td>37</td><td>36</td><td>35</td><td>34</td><td>33</td></tr> <tr><td colspan="2">73</td><td>32</td><td>31</td><td>30</td><td>29</td><td>28</td><td>27</td><td>26</td><td>25</td><td>24</td><td></td><td></td><td></td><td></td><td></td><td></td><td></td></tr> <tr><td colspan="2"></td><td>16</td><td>15</td><td>14</td><td>13</td><td></td><td></td><td>10</td><td>9</td><td>8</td><td></td><td></td><td></td><td></td><td></td><td></td><td></td></tr> </table>	72	71	70	68	67	66			62	61	60	59	58	57	56	55	54	53	52	51	50	48	47	46			42	41	40	39	38	37	36	35	34	33	73		32	31	30	29	28	27	26	25	24										16	15	14	13			10	9	8										
72	71	70	68	67	66			62	61	60	59	58	57	56	55	54	53																																																																	
52	51	50	48	47	46			42	41	40	39	38	37	36	35	34	33																																																																	
73		32	31	30	29	28	27	26	25	24																																																																								
		16	15	14	13			10	9	8																																																																								
AVAILABLE	NOT APPLICABLE	34566-4033	G	0	C	BLUE	<table border="1"> <tr><td>72</td><td>70</td><td>68</td><td></td><td></td><td></td><td></td><td>63</td><td>62</td><td></td><td>59</td><td>58</td><td>57</td><td></td><td></td><td></td><td></td><td>53</td></tr> <tr><td>52</td><td>51</td><td></td><td>48</td><td>47</td><td></td><td>44</td><td>42</td><td>41</td><td>40</td><td>39</td><td>38</td><td></td><td></td><td></td><td></td><td></td><td>34</td><td>33</td></tr> <tr><td colspan="2">73</td><td></td><td>32</td><td>30</td><td></td><td></td><td>26</td><td>25</td><td></td><td></td><td>22</td><td>21</td><td>20</td><td></td><td></td><td></td><td></td><td>17</td></tr> <tr><td colspan="2"></td><td></td><td>15</td><td>14</td><td>13</td><td></td><td></td><td></td><td></td><td></td><td>6</td><td>5</td><td>4</td><td></td><td></td><td></td><td></td><td>1</td></tr> </table>	72	70	68					63	62		59	58	57					53	52	51		48	47		44	42	41	40	39	38						34	33	73			32	30			26	25			22	21	20					17				15	14	13						6	5	4					1
72	70	68					63	62		59	58	57					53																																																																	
52	51		48	47		44	42	41	40	39	38						34	33																																																																
73			32	30			26	25			22	21	20					17																																																																
			15	14	13						6	5	4					1																																																																
AVAILABLE	NOT APPLICABLE	34566-4043	G	0	A	BLACK	<table border="1"> <tr><td></td><td>71</td><td>70</td><td>69</td><td>67</td><td></td><td></td><td>64</td><td>63</td><td></td><td>60</td><td></td><td></td><td>57</td><td>56</td><td>55</td><td>54</td><td>53</td></tr> <tr><td>52</td><td>51</td><td></td><td>49</td><td></td><td></td><td>45</td><td>44</td><td>43</td><td>42</td><td>41</td><td></td><td></td><td>37</td><td>36</td><td></td><td></td><td>34</td></tr> <tr><td colspan="2">73</td><td></td><td>32</td><td></td><td>30</td><td></td><td>28</td><td>26</td><td></td><td></td><td>23</td><td></td><td></td><td></td><td>19</td><td>18</td><td></td></tr> <tr><td colspan="2"></td><td></td><td>16</td><td>15</td><td></td><td></td><td>12</td><td>10</td><td></td><td></td><td></td><td></td><td></td><td></td><td>3</td><td></td><td></td></tr> </table>		71	70	69	67			64	63		60			57	56	55	54	53	52	51		49			45	44	43	42	41			37	36			34	73			32		30		28	26			23				19	18					16	15			12	10							3					
	71	70	69	67			64	63		60			57	56	55	54	53																																																																	
52	51		49			45	44	43	42	41			37	36			34																																																																	
73			32		30		28	26			23				19	18																																																																		
			16	15			12	10							3																																																																			
AVAILABLE	NOT APPLICABLE	34566-4053	G	0	A	BLACK	<table border="1"> <tr><td>72</td><td></td><td></td><td>69</td><td>67</td><td>66</td><td>65</td><td>63</td><td></td><td></td><td>60</td><td></td><td></td><td>57</td><td>56</td><td></td><td></td><td>53</td></tr> <tr><td></td><td></td><td></td><td>49</td><td></td><td>47</td><td>46</td><td>44</td><td>43</td><td>42</td><td>40</td><td></td><td></td><td>37</td><td>36</td><td>35</td><td></td><td>33</td></tr> <tr><td colspan="2">73</td><td></td><td>31</td><td>30</td><td>29</td><td>28</td><td>27</td><td>26</td><td>24</td><td></td><td></td><td>21</td><td>20</td><td></td><td></td><td></td><td>17</td></tr> <tr><td colspan="2"></td><td></td><td>16</td><td>15</td><td>14</td><td>13</td><td></td><td>11</td><td>10</td><td></td><td></td><td></td><td>5</td><td>4</td><td>3</td><td>2</td><td>1</td></tr> </table>	72			69	67	66	65	63			60			57	56			53				49		47	46	44	43	42	40			37	36	35		33	73			31	30	29	28	27	26	24			21	20				17				16	15	14	13		11	10				5	4	3	2	1			
72			69	67	66	65	63			60			57	56			53																																																																	
			49		47	46	44	43	42	40			37	36	35		33																																																																	
73			31	30	29	28	27	26	24			21	20				17																																																																	
			16	15	14	13		11	10				5	4	3	2	1																																																																	
AVAILABLE	NOT APPLICABLE	34566-4063	G	0	B	ST GRY	<table border="1"> <tr><td></td><td></td><td></td><td>68</td><td>67</td><td></td><td></td><td>64</td><td></td><td></td><td></td><td>59</td><td>58</td><td></td><td></td><td></td><td></td><td>54</td></tr> <tr><td></td><td></td><td></td><td></td><td>46</td><td>45</td><td></td><td></td><td></td><td></td><td></td><td>39</td><td>38</td><td></td><td></td><td></td><td></td><td></td><td>17</td></tr> <tr><td colspan="2">73</td><td></td><td>32</td><td>30</td><td>29</td><td>28</td><td>27</td><td></td><td></td><td></td><td>23</td><td>22</td><td></td><td></td><td></td><td></td><td></td><td>1</td></tr> <tr><td colspan="2"></td><td></td><td>15</td><td></td><td>13</td><td></td><td>10</td><td>8</td><td></td><td></td><td></td><td></td><td></td><td></td><td></td><td></td><td></td><td></td></tr> </table>				68	67			64				59	58					54					46	45						39	38						17	73			32	30	29	28	27				23	22						1				15		13		10	8										
			68	67			64				59	58					54																																																																	
				46	45						39	38						17																																																																
73			32	30	29	28	27				23	22						1																																																																
			15		13		10	8																																																																										
AVAILABLE	NOT APPLICABLE	34566-4073	G	0	A	BLACK	<table border="1"> <tr><td>72</td><td>70</td><td></td><td></td><td></td><td>66</td><td></td><td>63</td><td>62</td><td></td><td>59</td><td></td><td>57</td><td>56</td><td>55</td><td></td><td></td><td>53</td></tr> <tr><td>52</td><td>51</td><td></td><td></td><td></td><td>46</td><td>44</td><td>42</td><td>41</td><td>40</td><td>39</td><td></td><td>37</td><td>36</td><td></td><td></td><td></td><td>34</td><td>33</td></tr> <tr><td colspan="2">73</td><td></td><td>32</td><td>30</td><td></td><td></td><td>26</td><td>25</td><td></td><td></td><td>22</td><td>21</td><td>19</td><td>18</td><td></td><td></td><td></td><td></td></tr> <tr><td colspan="2"></td><td></td><td>15</td><td>14</td><td></td><td></td><td>10</td><td>9</td><td></td><td></td><td>6</td><td></td><td>3</td><td></td><td></td><td></td><td></td><td></td></tr> </table>	72	70				66		63	62		59		57	56	55			53	52	51				46	44	42	41	40	39		37	36				34	33	73			32	30			26	25			22	21	19	18								15	14			10	9			6		3					
72	70				66		63	62		59		57	56	55			53																																																																	
52	51				46	44	42	41	40	39		37	36				34	33																																																																
73			32	30			26	25			22	21	19	18																																																																				
			15	14			10	9			6		3																																																																					

ENTER DESCRIPTION REC NO: UAU2016-0232 DRAWN BY: G34 CHKD: G34 APPR: WOSHY 2015/08/14 2015/08/14 DESCRIPTION	QUALITY SYMBOLS	GENERAL TOLERANCES (UNLESS SPECIFIED)	DIMENSION STYLE	SCALE	DESIGN UNITS	THIRD ANGLE PROJECTION
	▽=0	mm INCH	MM ONLY		METRIC	
	▽=0	4 PLACES ± --- ± ---	DRAWN BY SKRA JENDRANA	DATE 2011/02/14	TITLE	MX123
	▽=0	3 PLACES ± --- ± ---	CHECKED BY MVANSLAMBROU	DATE 2011/02/14		66/73/80CKT
	2 PLACES ± --- ± ---	1 PLACE ± --- ± ---	APPROVED BY	DATE		HRNS CONN ASSY
	0 PLACE ± --- ± ---	ANGULAR ± ---°	MATERIAL NO.	DOCUMENT NO.		molex
	DRAFT WHERE APPLICABLE MUST REMAIN WITHIN DIMENSIONS	SEE BOM TABLE				SD-34566-001
						SHEET NO. 47 OF 85

STATUS	GM PART #	MATERIAL #	PART/MATERIAL REVISION	WIRE DRESS OPTION	KEY OPTION	COLOR (TPA)	NUMBERS INDICATE CAVITIES OPEN FOR CIRCUITS																																																																																											
AVAILABLE	NOT APPLICABLE	34566-4083	G	0	C	BLUE	<table border="1"> <tr><td>72</td><td>70</td><td>68</td><td></td><td></td><td></td><td>63</td><td>62</td><td></td><td></td><td>59</td><td>58</td><td>57</td><td></td><td></td><td>53</td></tr> <tr><td>52</td><td>51</td><td></td><td>48</td><td>47</td><td></td><td>44</td><td>42</td><td></td><td>40</td><td>39</td><td>38</td><td>37</td><td>36</td><td></td><td>34</td><td>33</td></tr> <tr><td></td><td></td><td></td><td>32</td><td></td><td>30</td><td></td><td></td><td></td><td>27</td><td>26</td><td>25</td><td>24</td><td></td><td>22</td><td>21</td><td>20</td><td>17</td></tr> <tr><td></td><td></td><td></td><td></td><td></td><td>15</td><td>14</td><td>13</td><td></td><td></td><td></td><td>8</td><td></td><td>6</td><td>5</td><td>4</td><td></td><td>2</td><td>1</td></tr> </table>	72	70	68				63	62			59	58	57			53	52	51		48	47		44	42		40	39	38	37	36		34	33				32		30				27	26	25	24		22	21	20	17						15	14	13				8		6	5	4		2	1																					
72	70	68				63	62			59	58	57			53																																																																																			
52	51		48	47		44	42		40	39	38	37	36		34	33																																																																																		
			32		30				27	26	25	24		22	21	20	17																																																																																	
					15	14	13				8		6	5	4		2	1																																																																																
AVAILABLE	NOT APPLICABLE	34566-4093	G	0	A	BLACK	<table border="1"> <tr><td></td><td>71</td><td>70</td><td>69</td><td></td><td>67</td><td></td><td></td><td>64</td><td>63</td><td></td><td></td><td>60</td><td></td><td></td><td>57</td><td>56</td><td>55</td><td>54</td><td>53</td></tr> <tr><td></td><td>52</td><td>51</td><td></td><td>49</td><td></td><td>47</td><td></td><td>45</td><td>44</td><td>43</td><td>42</td><td>41</td><td></td><td></td><td>37</td><td>36</td><td></td><td>34</td><td></td></tr> <tr><td></td><td></td><td></td><td></td><td></td><td></td><td>32</td><td></td><td>30</td><td></td><td>28</td><td></td><td>26</td><td></td><td>23</td><td></td><td></td><td>19</td><td>18</td><td></td></tr> <tr><td></td><td></td><td></td><td></td><td></td><td></td><td>16</td><td>15</td><td></td><td></td><td>12</td><td>10</td><td></td><td></td><td></td><td></td><td></td><td>3</td><td></td><td></td></tr> </table>		71	70	69		67			64	63			60			57	56	55	54	53		52	51		49		47		45	44	43	42	41			37	36		34								32		30		28		26		23			19	18								16	15			12	10						3													
	71	70	69		67			64	63			60			57	56	55	54	53																																																																															
	52	51		49		47		45	44	43	42	41			37	36		34																																																																																
						32		30		28		26		23			19	18																																																																																
						16	15			12	10						3																																																																																	
AVAILABLE	NOT APPLICABLE	34566-4113	G	0	B	ST GRAY	<table border="1"> <tr><td></td><td></td><td></td><td>68</td><td>67</td><td></td><td></td><td>64</td><td></td><td></td><td></td><td></td><td></td><td></td><td></td><td>58</td><td></td><td></td><td></td><td></td></tr> <tr><td></td><td></td><td></td><td></td><td></td><td></td><td></td><td>46</td><td>45</td><td></td><td></td><td></td><td></td><td></td><td></td><td>38</td><td></td><td></td><td></td><td></td></tr> <tr><td></td><td></td><td></td><td></td><td></td><td></td><td></td><td>32</td><td></td><td>30</td><td>29</td><td>28</td><td>27</td><td></td><td></td><td>22</td><td></td><td></td><td></td><td>17</td></tr> <tr><td></td><td></td><td></td><td></td><td></td><td></td><td></td><td></td><td>15</td><td>13</td><td></td><td></td><td>10</td><td></td><td></td><td></td><td></td><td></td><td></td><td>1</td></tr> </table>				68	67			64								58												46	45							38												32		30	29	28	27			22				17									15	13			10							1											
			68	67			64								58																																																																																			
							46	45							38																																																																																			
							32		30	29	28	27			22				17																																																																															
								15	13			10							1																																																																															
AVAILABLE	NOT APPLICABLE	34566-4123	G	9	A	BLACK	<table border="1"> <tr><td>72</td><td></td><td></td><td>69</td><td></td><td>67</td><td>66</td><td>65</td><td></td><td>63</td><td></td><td></td><td>60</td><td></td><td></td><td>57</td><td>56</td><td></td><td></td><td>53</td></tr> <tr><td></td><td></td><td></td><td>49</td><td></td><td>47</td><td>46</td><td></td><td>44</td><td>43</td><td>42</td><td></td><td>40</td><td></td><td></td><td>37</td><td>36</td><td>35</td><td></td><td>33</td></tr> <tr><td></td><td></td><td></td><td></td><td></td><td>31</td><td>30</td><td>29</td><td>28</td><td></td><td>26</td><td></td><td>24</td><td></td><td></td><td>21</td><td>20</td><td></td><td></td><td>17</td></tr> <tr><td></td><td></td><td></td><td></td><td></td><td>16</td><td>15</td><td>14</td><td>13</td><td></td><td>11</td><td>10</td><td></td><td></td><td></td><td>5</td><td>4</td><td>3</td><td></td><td>2</td><td>1</td></tr> </table>	72			69		67	66	65		63			60			57	56			53				49		47	46		44	43	42		40			37	36	35		33						31	30	29	28		26		24			21	20			17						16	15	14	13		11	10				5	4	3		2	1										
72			69		67	66	65		63			60			57	56			53																																																																															
			49		47	46		44	43	42		40			37	36	35		33																																																																															
					31	30	29	28		26		24			21	20			17																																																																															
					16	15	14	13		11	10				5	4	3		2	1																																																																														
AVAILABLE	NOT APPLICABLE	34566-4133	G	9	B	ST GRAY	<table border="1"> <tr><td></td><td></td><td></td><td>68</td><td>67</td><td></td><td></td><td>64</td><td></td><td></td><td></td><td></td><td>59</td><td>58</td><td></td><td></td><td></td><td></td><td></td><td>54</td></tr> <tr><td></td><td></td><td></td><td></td><td></td><td></td><td></td><td>46</td><td>45</td><td></td><td></td><td></td><td></td><td>39</td><td>38</td><td></td><td></td><td></td><td></td><td></td></tr> <tr><td></td><td></td><td></td><td></td><td></td><td></td><td></td><td>32</td><td></td><td>30</td><td>29</td><td>28</td><td>27</td><td></td><td></td><td>23</td><td>22</td><td></td><td></td><td>17</td></tr> <tr><td></td><td></td><td></td><td></td><td></td><td></td><td></td><td></td><td>15</td><td>13</td><td></td><td></td><td>10</td><td>9</td><td>8</td><td></td><td></td><td></td><td></td><td>1</td></tr> </table>				68	67			64					59	58						54								46	45					39	38													32		30	29	28	27			23	22			17									15	13			10	9	8					1											
			68	67			64					59	58						54																																																																															
							46	45					39	38																																																																																				
							32		30	29	28	27			23	22			17																																																																															
								15	13			10	9	8					1																																																																															
AVAILABLE	NOT APPLICABLE	34566-4143	G	0	B	ST GRAY	<table border="1"> <tr><td></td><td></td><td></td><td>68</td><td>67</td><td></td><td></td><td>64</td><td></td><td></td><td></td><td></td><td>59</td><td>58</td><td></td><td></td><td></td><td></td><td></td><td>54</td></tr> <tr><td></td><td></td><td></td><td></td><td></td><td></td><td></td><td>46</td><td>45</td><td></td><td></td><td></td><td></td><td>39</td><td>38</td><td></td><td></td><td></td><td></td><td></td></tr> <tr><td></td><td></td><td></td><td></td><td></td><td></td><td></td><td>32</td><td></td><td>30</td><td>29</td><td>28</td><td>27</td><td></td><td></td><td>23</td><td>22</td><td></td><td></td><td>17</td></tr> <tr><td></td><td></td><td></td><td></td><td></td><td></td><td></td><td></td><td></td><td></td><td></td><td></td><td>10</td><td>9</td><td></td><td></td><td></td><td></td><td></td><td>1</td></tr> </table>				68	67			64					59	58						54								46	45					39	38													32		30	29	28	27			23	22			17													10	9						1											
			68	67			64					59	58						54																																																																															
							46	45					39	38																																																																																				
							32		30	29	28	27			23	22			17																																																																															
												10	9						1																																																																															
AVAILABLE	NOT APPLICABLE	34566-4153	G	0	B	ST GRAY	<table border="1"> <tr><td>72</td><td>70</td><td></td><td>68</td><td></td><td>66</td><td></td><td></td><td></td><td></td><td></td><td></td><td>60</td><td>59</td><td></td><td></td><td></td><td></td><td>55</td><td>54</td><td>53</td></tr> <tr><td></td><td></td><td></td><td>48</td><td></td><td>46</td><td></td><td>44</td><td></td><td></td><td></td><td></td><td>40</td><td>39</td><td></td><td></td><td></td><td></td><td></td><td>35</td><td>34</td><td>33</td></tr> <tr><td></td><td></td><td></td><td>32</td><td>31</td><td>30</td><td>29</td><td>28</td><td>27</td><td>26</td><td>25</td><td>24</td><td>23</td><td></td><td></td><td></td><td></td><td></td><td></td><td>19</td><td>18</td><td></td></tr> <tr><td></td><td></td><td></td><td></td><td></td><td></td><td></td><td></td><td></td><td></td><td></td><td>10</td><td>9</td><td>8</td><td>7</td><td></td><td></td><td></td><td></td><td></td><td></td><td></td></tr> </table>	72	70		68		66							60	59					55	54	53				48		46		44					40	39						35	34	33				32	31	30	29	28	27	26	25	24	23							19	18													10	9	8	7											
72	70		68		66							60	59					55	54	53																																																																														
			48		46		44					40	39						35	34	33																																																																													
			32	31	30	29	28	27	26	25	24	23							19	18																																																																														
											10	9	8	7																																																																																				
AVAILABLE	NOT APPLICABLE	34566-4163	G	0	B	ST GRAY	<table border="1"> <tr><td>72</td><td>70</td><td></td><td>68</td><td></td><td>66</td><td></td><td></td><td></td><td></td><td></td><td></td><td>60</td><td>59</td><td></td><td></td><td></td><td></td><td></td><td>55</td><td>54</td><td>53</td></tr> <tr><td></td><td></td><td></td><td>48</td><td></td><td>46</td><td></td><td>44</td><td></td><td></td><td></td><td></td><td>40</td><td>39</td><td></td><td></td><td></td><td></td><td></td><td></td><td>35</td><td>34</td><td>33</td></tr> <tr><td></td><td></td><td></td><td>32</td><td>31</td><td>30</td><td>29</td><td>28</td><td>27</td><td>26</td><td>25</td><td>24</td><td>23</td><td></td><td></td><td></td><td></td><td></td><td></td><td></td><td>19</td><td>18</td><td></td></tr> <tr><td></td><td></td><td></td><td></td><td></td><td></td><td></td><td></td><td></td><td></td><td></td><td>10</td><td>9</td><td>8</td><td>7</td><td></td><td></td><td></td><td></td><td></td><td></td><td></td><td></td></tr> </table>	72	70		68		66							60	59						55	54	53				48		46		44					40	39							35	34	33				32	31	30	29	28	27	26	25	24	23								19	18													10	9	8	7								
72	70		68		66							60	59						55	54	53																																																																													
			48		46		44					40	39							35	34	33																																																																												
			32	31	30	29	28	27	26	25	24	23								19	18																																																																													
											10	9	8	7																																																																																				
AVAILABLE	NOT APPLICABLE	34566-4173	G	0	A	BLACK	<table border="1"> <tr><td>72</td><td>71</td><td>70</td><td>69</td><td></td><td></td><td></td><td></td><td>64</td><td>63</td><td></td><td></td><td>60</td><td>59</td><td>58</td><td></td><td>56</td><td>55</td><td>54</td><td>53</td></tr> <tr><td></td><td></td><td></td><td></td><td></td><td></td><td></td><td></td><td>45</td><td>44</td><td>43</td><td>42</td><td>41</td><td></td><td></td><td>38</td><td></td><td>36</td><td></td><td>34</td></tr> <tr><td></td><td></td><td></td><td></td><td></td><td></td><td></td><td></td><td>32</td><td></td><td>30</td><td></td><td>28</td><td></td><td>26</td><td>25</td><td></td><td>22</td><td>21</td><td>20</td><td>17</td></tr> <tr><td></td><td></td><td></td><td></td><td></td><td></td><td></td><td></td><td>16</td><td>15</td><td></td><td></td><td>12</td><td>10</td><td>9</td><td>8</td><td></td><td>5</td><td></td><td>3</td><td></td><td></td></tr> </table>	72	71	70	69					64	63			60	59	58		56	55	54	53									45	44	43	42	41			38		36		34									32		30		28		26	25		22	21	20	17									16	15			12	10	9	8		5		3										
72	71	70	69					64	63			60	59	58		56	55	54	53																																																																															
								45	44	43	42	41			38		36		34																																																																															
								32		30		28		26	25		22	21	20	17																																																																														
								16	15			12	10	9	8		5		3																																																																															

ENTER DESCRIPTION ELEC NO: UAU2016-0232 DRAWN BY: 2015/08/14 CHKD: 2015/08/14 APPR: IKOSHY	QUALITY SYMBOLS ∇=0 ∇=0 ∇=0	GENERAL TOLERANCES (UNLESS SPECIFIED) mm INCH 4 PLACES #--- #--- 3 PLACES #--- #--- 2 PLACES #--- #--- 1 PLACE #--- #--- 0 PLACE #--- #--- ANGULAR ±---° DRAFT WHERE APPLICABLE MUST REMAIN WITHIN DIMENSIONS	DIMENSION STYLE MM ONLY	SCALE DESIGN UNITS METRIC	THIRD ANGLE PROJECTION	
	DRAWN BY: SKRAJENDRANA DATE: 2011/02/14 CHECKED BY: MYANSLAMBROU DATE: 2011/02/14 APPROVED BY:	TITLE MX123 66/73/80CKT HRNS CONN ASSY	MATERIAL NO. SD-34566-001	DOCUMENT NO.	SHEET NO. 48 OF 85	SIZE THIS DRAWING CONTAINS INFORMATION THAT IS PROPRIETARY TO MOLEX INCORPORATED AND SHOULD NOT BE USED WITHOUT WRITTEN PERMISSION
	SEE BOM TABLE	SEE BOM TABLE	SEE BOM TABLE	SEE BOM TABLE	SEE BOM TABLE	SEE BOM TABLE
	SEE BOM TABLE	SEE BOM TABLE	SEE BOM TABLE	SEE BOM TABLE	SEE BOM TABLE	SEE BOM TABLE

STATUS	GM PART #	MATERIAL #	PART/MATERIAL REVISION	WIRE DRESS OPTION	KEY OPTION	COLOR (TPA)	NUMBERS INDICATE CAVITIES OPEN FOR CIRCUITS																																																																							
AVAILABLE	NOT APPLICABLE	34566-4183	G	0	C	BLUE	<table border="1"> <tr><td>72</td><td>70</td><td>68</td><td>66</td><td>63</td><td>62</td><td>59</td><td>58</td><td>57</td><td></td><td>53</td></tr> <tr><td>52</td><td>51</td><td>48</td><td>47</td><td>46</td><td>44</td><td>42</td><td>40</td><td>39</td><td></td><td>34</td><td>33</td></tr> <tr><td>73</td><td></td><td>32</td><td>30</td><td></td><td></td><td>23</td><td>22</td><td>21</td><td>20</td><td></td><td>17</td></tr> <tr><td></td><td></td><td>15</td><td>14</td><td>13</td><td></td><td>10</td><td>9</td><td>7</td><td>6</td><td>5</td><td>4</td><td>1</td></tr> </table>	72	70	68	66	63	62	59	58	57		53	52	51	48	47	46	44	42	40	39		34	33	73		32	30			23	22	21	20		17			15	14	13		10	9	7	6	5	4	1																							
72	70	68	66	63	62	59	58	57		53																																																																				
52	51	48	47	46	44	42	40	39		34	33																																																																			
73		32	30			23	22	21	20		17																																																																			
		15	14	13		10	9	7	6	5	4	1																																																																		
AVAILABLE	NOT APPLICABLE	34566-4193	G	0	C	BLUE	<table border="1"> <tr><td>71</td><td>69</td><td></td><td>65</td><td>64</td><td></td><td>61</td><td>60</td><td>58</td><td>56</td><td>55</td><td>54</td></tr> <tr><td></td><td>50</td><td>49</td><td>45</td><td>43</td><td></td><td>41</td><td></td><td>38</td><td>37</td><td>36</td><td>35</td></tr> <tr><td>73</td><td></td><td></td><td>31</td><td>29</td><td>28</td><td></td><td>24</td><td>23</td><td>22</td><td>21</td><td>20</td><td>19</td><td>18</td><td>17</td></tr> <tr><td></td><td></td><td>16</td><td>13</td><td>12</td><td>11</td><td></td><td>8</td><td>7</td><td></td><td></td><td>3</td><td>2</td><td>1</td></tr> </table>	71	69		65	64		61	60	58	56	55	54		50	49	45	43		41		38	37	36	35	73			31	29	28		24	23	22	21	20	19	18	17			16	13	12	11		8	7			3	2	1																		
71	69		65	64		61	60	58	56	55	54																																																																			
	50	49	45	43		41		38	37	36	35																																																																			
73			31	29	28		24	23	22	21	20	19	18	17																																																																
		16	13	12	11		8	7			3	2	1																																																																	
AVAILABLE	NOT APPLICABLE	34566-4213	G	0	A	BLACK	<table border="1"> <tr><td>72</td><td>71</td><td>68</td><td>67</td><td>66</td><td>65</td><td>64</td><td></td><td>60</td><td>59</td><td>58</td><td></td><td></td><td></td><td></td></tr> <tr><td></td><td>50</td><td>48</td><td>47</td><td>46</td><td>45</td><td></td><td></td><td>40</td><td>39</td><td>38</td><td></td><td></td><td>35</td><td></td></tr> <tr><td>73</td><td></td><td></td><td>31</td><td>30</td><td></td><td></td><td></td><td>25</td><td>24</td><td>22</td><td>21</td><td>20</td><td></td><td>17</td></tr> <tr><td></td><td></td><td></td><td></td><td>14</td><td></td><td></td><td></td><td>9</td><td>7</td><td>6</td><td>5</td><td>4</td><td></td><td>2</td><td>1</td></tr> </table>	72	71	68	67	66	65	64		60	59	58						50	48	47	46	45			40	39	38			35		73			31	30				25	24	22	21	20		17					14				9	7	6	5	4		2	1										
72	71	68	67	66	65	64		60	59	58																																																																				
	50	48	47	46	45			40	39	38			35																																																																	
73			31	30				25	24	22	21	20		17																																																																
				14				9	7	6	5	4		2	1																																																															
AVAILABLE	NOT APPLICABLE	34566-4223	G	0	A	BLACK	<table border="1"> <tr><td>72</td><td>71</td><td>68</td><td>67</td><td>66</td><td>65</td><td>64</td><td></td><td>60</td><td>59</td><td>58</td><td></td><td></td><td></td><td></td></tr> <tr><td></td><td>50</td><td>48</td><td>47</td><td>46</td><td>45</td><td></td><td></td><td>40</td><td>39</td><td>38</td><td></td><td></td><td>35</td><td>33</td></tr> <tr><td>73</td><td></td><td></td><td>31</td><td>30</td><td></td><td></td><td></td><td>25</td><td>24</td><td>23</td><td>22</td><td>21</td><td>20</td><td></td><td>17</td></tr> <tr><td></td><td></td><td></td><td></td><td>14</td><td></td><td></td><td></td><td>9</td><td>8</td><td>7</td><td>6</td><td>5</td><td>4</td><td></td><td>2</td><td>1</td></tr> </table>	72	71	68	67	66	65	64		60	59	58						50	48	47	46	45			40	39	38			35	33	73			31	30				25	24	23	22	21	20		17					14				9	8	7	6	5	4		2	1								
72	71	68	67	66	65	64		60	59	58																																																																				
	50	48	47	46	45			40	39	38			35	33																																																																
73			31	30				25	24	23	22	21	20		17																																																															
				14				9	8	7	6	5	4		2	1																																																														
AVAILABLE	NOT APPLICABLE	34566-4233	G	0	B	ST GRY	<table border="1"> <tr><td></td><td></td><td>69</td><td></td><td>65</td><td>64</td><td>63</td><td></td><td></td><td></td><td></td><td></td><td></td><td></td><td></td><td></td></tr> <tr><td></td><td></td><td>49</td><td></td><td>45</td><td>44</td><td>43</td><td></td><td></td><td></td><td></td><td></td><td></td><td></td><td></td><td></td></tr> <tr><td>73</td><td></td><td></td><td></td><td></td><td></td><td></td><td></td><td></td><td></td><td>23</td><td>22</td><td>21</td><td>20</td><td>19</td><td>18</td></tr> <tr><td></td><td></td><td></td><td></td><td></td><td></td><td>12</td><td>11</td><td>9</td><td></td><td>7</td><td>6</td><td>5</td><td>4</td><td>3</td><td></td></tr> </table>			69		65	64	63												49		45	44	43										73										23	22	21	20	19	18							12	11	9		7	6	5	4	3								
		69		65	64	63																																																																								
		49		45	44	43																																																																								
73										23	22	21	20	19	18																																																															
						12	11	9		7	6	5	4	3																																																																
AVAILABLE	NOT APPLICABLE	34566-4243	G	0	A	BLACK	<table border="1"> <tr><td></td><td>51</td><td>50</td><td></td><td>47</td><td>46</td><td></td><td></td><td>61</td><td>58</td><td>57</td><td>56</td><td></td><td></td><td></td><td></td></tr> <tr><td>73</td><td></td><td></td><td></td><td>31</td><td>30</td><td></td><td></td><td>26</td><td>22</td><td>21</td><td>20</td><td></td><td></td><td></td><td></td></tr> <tr><td></td><td></td><td></td><td></td><td>15</td><td>14</td><td></td><td></td><td>10</td><td></td><td></td><td></td><td></td><td></td><td></td><td></td></tr> </table>		51	50		47	46			61	58	57	56					73				31	30			26	22	21	20									15	14			10																														
	51	50		47	46			61	58	57	56																																																																			
73				31	30			26	22	21	20																																																																			
				15	14			10																																																																						
AVAILABLE	NOT APPLICABLE	34566-4253	G	0	A	BLACK	<table border="1"> <tr><td></td><td>51</td><td>50</td><td></td><td>47</td><td>46</td><td>45</td><td></td><td></td><td>61</td><td>58</td><td>57</td><td>56</td><td></td><td></td><td></td></tr> <tr><td>73</td><td></td><td></td><td></td><td>31</td><td>30</td><td></td><td></td><td>26</td><td>22</td><td>21</td><td>20</td><td></td><td></td><td></td><td></td></tr> <tr><td></td><td></td><td></td><td></td><td>15</td><td>14</td><td></td><td></td><td>10</td><td></td><td></td><td></td><td></td><td></td><td></td><td></td></tr> </table>		51	50		47	46	45			61	58	57	56				73				31	30			26	22	21	20									15	14			10																														
	51	50		47	46	45			61	58	57	56																																																																		
73				31	30			26	22	21	20																																																																			
				15	14			10																																																																						
AVAILABLE	NOT APPLICABLE	34566-4263	G	0	B	ST GRY	<table border="1"> <tr><td>72</td><td>71</td><td>70</td><td>69</td><td>68</td><td></td><td>65</td><td>64</td><td>62</td><td>61</td><td>60</td><td></td><td></td><td></td><td></td><td>54</td></tr> <tr><td>52</td><td>51</td><td></td><td></td><td>47</td><td>46</td><td>44</td><td>42</td><td>41</td><td>40</td><td></td><td></td><td></td><td></td><td></td><td></td></tr> <tr><td>73</td><td></td><td></td><td>32</td><td>31</td><td>30</td><td>28</td><td>26</td><td>25</td><td>24</td><td></td><td></td><td></td><td></td><td>20</td><td>19</td><td>17</td></tr> <tr><td></td><td></td><td></td><td></td><td></td><td></td><td>12</td><td>11</td><td>10</td><td>9</td><td></td><td></td><td></td><td></td><td></td><td></td><td>2</td><td>1</td></tr> </table>	72	71	70	69	68		65	64	62	61	60					54	52	51			47	46	44	42	41	40							73			32	31	30	28	26	25	24					20	19	17							12	11	10	9							2	1				
72	71	70	69	68		65	64	62	61	60					54																																																															
52	51			47	46	44	42	41	40																																																																					
73			32	31	30	28	26	25	24					20	19	17																																																														
						12	11	10	9							2	1																																																													
AVAILABLE	NOT APPLICABLE	34566-4273	G	0	B	ST GRY	<table border="1"> <tr><td>72</td><td>71</td><td>70</td><td>69</td><td>68</td><td>67</td><td>66</td><td>65</td><td>64</td><td>62</td><td>61</td><td>60</td><td></td><td></td><td></td><td></td><td>54</td></tr> <tr><td>52</td><td>51</td><td></td><td></td><td>47</td><td>45</td><td>44</td><td>42</td><td>41</td><td>40</td><td></td><td></td><td></td><td></td><td></td><td></td><td></td></tr> <tr><td>73</td><td></td><td></td><td>32</td><td>31</td><td>30</td><td>28</td><td>26</td><td>25</td><td>24</td><td></td><td></td><td></td><td></td><td></td><td>20</td><td>19</td><td>17</td></tr> <tr><td></td><td></td><td></td><td></td><td></td><td></td><td>13</td><td>12</td><td>11</td><td>10</td><td>9</td><td>8</td><td></td><td></td><td></td><td></td><td></td><td>2</td><td>1</td></tr> </table>	72	71	70	69	68	67	66	65	64	62	61	60					54	52	51			47	45	44	42	41	40								73			32	31	30	28	26	25	24						20	19	17							13	12	11	10	9	8						2	1
72	71	70	69	68	67	66	65	64	62	61	60					54																																																														
52	51			47	45	44	42	41	40																																																																					
73			32	31	30	28	26	25	24						20	19	17																																																													
						13	12	11	10	9	8						2	1																																																												

ENTER DESCRIPTION EC NO: UAU2016-0232 DRAWN BY: SKRA CHKD: MYANSLAMBROU APPR: IKOSHY 2015/08/14 2015/08/14 2015/08/14	QUALITY SYMBOLS ∇=0 ∇=0 ∇=0	GENERAL TOLERANCES (UNLESS SPECIFIED) <table border="1"> <tr><td></td><td>mm</td><td>INCH</td></tr> <tr><td>4 PLACES</td><td>±---</td><td>±---</td></tr> <tr><td>3 PLACES</td><td>±---</td><td>±---</td></tr> <tr><td>2 PLACES</td><td>±---</td><td>±---</td></tr> <tr><td>1 PLACE</td><td>±---</td><td>±---</td></tr> <tr><td>0 PLACE</td><td>±---</td><td>±---</td></tr> </table>		mm	INCH	4 PLACES	±---	±---	3 PLACES	±---	±---	2 PLACES	±---	±---	1 PLACE	±---	±---	0 PLACE	±---	±---	DIMENSION STYLE MM ONLY	SCALE METRIC	DESIGN UNITS METRIC	THIRD ANGLE PROJECTION
		mm	INCH																					
	4 PLACES	±---	±---																					
	3 PLACES	±---	±---																					
2 PLACES	±---	±---																						
1 PLACE	±---	±---																						
0 PLACE	±---	±---																						
DRAWN BY: SKRA JENDRANA 2011/02/14 CHECKED BY: MYANSLAMBROU 2011/02/14 APPROVED BY:	DATE:	DATE:	DATE:	DATE:	DATE:	DATE:																		
MATERIAL NO.	DOCUMENT NO.	SHEET NO.	TITLE MX123 66/73/80CKT HRNS CONN ASSY	SIZE SEE BOM TABLE	SIZE SD-34566-001	SHEET NO. 49 OF 85																		
THIS DRAWING CONTAINS INFORMATION THAT IS PROPRIETARY TO MOLEX INCORPORATED AND SHOULD NOT BE USED WITHOUT WRITTEN PERMISSION																								

STATUS	GM PART #	MATERIAL #	PART/MATERIAL REVISION	WIRE DRESS OPTION	KEY OPTION	COLOR (TPA)	NUMBERS INDICATE CAVITIES OPEN FOR CIRCUITS																																																																												
AVAILABLE	NOT APPLICABLE	34566-4383	G	0	H	ST GRV	<table border="1"> <tr><td>79</td><td></td><td></td><td></td><td>74</td><td>73</td><td>72</td><td>71</td><td>69</td><td>68</td><td>67</td><td></td><td>64</td><td>62</td><td>61</td></tr> <tr><td>59</td><td></td><td></td><td></td><td>54</td><td>52</td><td></td><td></td><td>49</td><td>48</td><td>47</td><td></td><td></td><td>42</td><td>41</td></tr> <tr><td></td><td>38</td><td></td><td></td><td></td><td>33</td><td></td><td></td><td>29</td><td>27</td><td>25</td><td></td><td></td><td></td><td></td></tr> <tr><td></td><td>18</td><td></td><td>15</td><td>14</td><td></td><td></td><td>11</td><td>10</td><td>9</td><td>8</td><td>7</td><td></td><td></td><td></td></tr> </table>	79				74	73	72	71	69	68	67		64	62	61	59				54	52			49	48	47			42	41		38				33			29	27	25						18		15	14			11	10	9	8	7																			
79				74	73	72	71	69	68	67		64	62	61																																																																					
59				54	52			49	48	47			42	41																																																																					
	38				33			29	27	25																																																																									
	18		15	14			11	10	9	8	7																																																																								
AVAILABLE	NOT APPLICABLE	34566-4393	G	0	G	BLUE	<table border="1"> <tr><td></td><td>78</td><td>77</td><td>75</td><td>74</td><td>72</td><td>70</td><td>69</td><td>67</td><td>65</td><td>64</td><td>63</td><td>62</td><td></td><td></td></tr> <tr><td>60</td><td>58</td><td>57</td><td>55</td><td>54</td><td>52</td><td>51</td><td>50</td><td>49</td><td>47</td><td>45</td><td></td><td></td><td></td><td></td></tr> <tr><td>40</td><td>38</td><td>37</td><td></td><td></td><td>33</td><td>32</td><td>31</td><td></td><td>27</td><td>26</td><td>25</td><td>24</td><td></td><td></td></tr> <tr><td>20</td><td>18</td><td>17</td><td></td><td></td><td></td><td></td><td>10</td><td>9</td><td>8</td><td>6</td><td>5</td><td>3</td><td>2</td><td>1</td></tr> </table>		78	77	75	74	72	70	69	67	65	64	63	62			60	58	57	55	54	52	51	50	49	47	45					40	38	37			33	32	31		27	26	25	24			20	18	17					10	9	8	6	5	3	2	1																
	78	77	75	74	72	70	69	67	65	64	63	62																																																																							
60	58	57	55	54	52	51	50	49	47	45																																																																									
40	38	37			33	32	31		27	26	25	24																																																																							
20	18	17					10	9	8	6	5	3	2	1																																																																					
AVAILABLE	NOT APPLICABLE	34566-4413	G	0	B	ST GRV	<table border="1"> <tr><td></td><td></td><td></td><td></td><td></td><td></td><td>63</td><td></td><td>59</td><td>58</td><td>57</td><td>56</td><td>55</td><td>53</td><td></td></tr> <tr><td></td><td>50</td><td>49</td><td>48</td><td></td><td>46</td><td></td><td>43</td><td></td><td>39</td><td>38</td><td>37</td><td>36</td><td>35</td><td>34</td></tr> <tr><td></td><td></td><td></td><td></td><td></td><td>29</td><td>27</td><td></td><td></td><td>23</td><td>22</td><td>21</td><td></td><td>18</td><td></td></tr> <tr><td>73</td><td></td><td></td><td>16</td><td>15</td><td>14</td><td></td><td></td><td></td><td>7</td><td>6</td><td>5</td><td>4</td><td>3</td><td></td></tr> </table>							63		59	58	57	56	55	53			50	49	48		46		43		39	38	37	36	35	34						29	27			23	22	21		18		73			16	15	14				7	6	5	4	3																	
						63		59	58	57	56	55	53																																																																						
	50	49	48		46		43		39	38	37	36	35	34																																																																					
					29	27			23	22	21		18																																																																						
73			16	15	14				7	6	5	4	3																																																																						
AVAILABLE	NOT APPLICABLE	34566-4423	G	9	C	BLUE	<table border="1"> <tr><td>72</td><td>70</td><td>68</td><td>67</td><td>66</td><td></td><td>63</td><td>62</td><td></td><td>59</td><td>57</td><td></td><td></td><td>53</td><td></td></tr> <tr><td>52</td><td>51</td><td></td><td>48</td><td>47</td><td>46</td><td>44</td><td>42</td><td></td><td>40</td><td>39</td><td>38</td><td>37</td><td>36</td><td>34</td></tr> <tr><td></td><td></td><td></td><td>32</td><td>30</td><td></td><td>27</td><td>26</td><td>25</td><td>24</td><td>22</td><td>21</td><td></td><td></td><td>33</td></tr> <tr><td>73</td><td></td><td></td><td>15</td><td>14</td><td></td><td></td><td>10</td><td>9</td><td>8</td><td>6</td><td>5</td><td>4</td><td></td><td>2</td></tr> </table>	72	70	68	67	66		63	62		59	57			53		52	51		48	47	46	44	42		40	39	38	37	36	34				32	30		27	26	25	24	22	21			33	73			15	14			10	9	8	6	5	4		2																
72	70	68	67	66		63	62		59	57			53																																																																						
52	51		48	47	46	44	42		40	39	38	37	36	34																																																																					
			32	30		27	26	25	24	22	21			33																																																																					
73			15	14			10	9	8	6	5	4		2																																																																					
AVAILABLE	NOT APPLICABLE	34566-4433	G	9	A	BLACK	<table border="1"> <tr><td></td><td>70</td><td>69</td><td></td><td></td><td></td><td>63</td><td>62</td><td>61</td><td>60</td><td>58</td><td>57</td><td>56</td><td>55</td><td>54</td><td>53</td></tr> <tr><td>52</td><td>51</td><td>50</td><td>49</td><td></td><td></td><td>44</td><td>43</td><td>42</td><td>41</td><td>40</td><td></td><td>37</td><td>36</td><td></td><td>34</td></tr> <tr><td></td><td></td><td></td><td></td><td></td><td></td><td>29</td><td>28</td><td>27</td><td>26</td><td></td><td></td><td></td><td></td><td>19</td><td>18</td></tr> <tr><td>73</td><td></td><td></td><td>16</td><td>15</td><td>14</td><td>13</td><td>12</td><td>11</td><td>10</td><td></td><td></td><td></td><td>3</td><td></td><td></td></tr> </table>		70	69				63	62	61	60	58	57	56	55	54	53	52	51	50	49			44	43	42	41	40		37	36		34							29	28	27	26					19	18	73			16	15	14	13	12	11	10				3														
	70	69				63	62	61	60	58	57	56	55	54	53																																																																				
52	51	50	49			44	43	42	41	40		37	36		34																																																																				
						29	28	27	26					19	18																																																																				
73			16	15	14	13	12	11	10				3																																																																						
AVAILABLE	NOT APPLICABLE	34566-4443	G	9	A	BLACK	<table border="1"> <tr><td></td><td></td><td></td><td></td><td>67</td><td>66</td><td></td><td></td><td></td><td></td><td></td><td></td><td></td><td></td><td></td><td></td></tr> <tr><td></td><td></td><td></td><td></td><td>48</td><td>47</td><td></td><td></td><td>41</td><td></td><td></td><td></td><td></td><td></td><td></td><td></td></tr> <tr><td></td><td></td><td></td><td></td><td>32</td><td>31</td><td>30</td><td>29</td><td>27</td><td>26</td><td>25</td><td></td><td></td><td></td><td>19</td><td>18</td></tr> <tr><td>73</td><td></td><td></td><td>16</td><td>15</td><td>14</td><td>13</td><td>11</td><td>10</td><td>9</td><td>8</td><td>7</td><td>6</td><td>5</td><td>4</td><td>3</td></tr> </table>					67	66															48	47			41												32	31	30	29	27	26	25				19	18	73			16	15	14	13	11	10	9	8	7	6	5	4	3												
				67	66																																																																														
				48	47			41																																																																											
				32	31	30	29	27	26	25				19	18																																																																				
73			16	15	14	13	11	10	9	8	7	6	5	4	3																																																																				
AVAILABLE	NOT APPLICABLE	34566-4453	G	0	A	BLACK	<table border="1"> <tr><td>72</td><td>71</td><td>70</td><td>69</td><td>68</td><td></td><td>65</td><td>64</td><td>63</td><td>62</td><td>61</td><td>60</td><td>59</td><td>58</td><td>57</td><td>56</td><td>55</td><td>54</td><td>53</td></tr> <tr><td>52</td><td>51</td><td>50</td><td>49</td><td>48</td><td></td><td>46</td><td>45</td><td>44</td><td>43</td><td>42</td><td>40</td><td>39</td><td>38</td><td>37</td><td>36</td><td>35</td><td>34</td><td>33</td></tr> <tr><td></td><td></td><td></td><td></td><td></td><td></td><td></td><td></td><td>28</td><td></td><td></td><td>24</td><td>23</td><td></td><td>20</td><td></td><td></td><td></td><td></td></tr> <tr><td>73</td><td></td><td></td><td></td><td></td><td></td><td></td><td></td><td>12</td><td>11</td><td></td><td></td><td></td><td></td><td></td><td></td><td></td><td>2</td><td>1</td></tr> </table>	72	71	70	69	68		65	64	63	62	61	60	59	58	57	56	55	54	53	52	51	50	49	48		46	45	44	43	42	40	39	38	37	36	35	34	33									28			24	23		20					73								12	11								2	1
72	71	70	69	68		65	64	63	62	61	60	59	58	57	56	55	54	53																																																																	
52	51	50	49	48		46	45	44	43	42	40	39	38	37	36	35	34	33																																																																	
								28			24	23		20																																																																					
73								12	11								2	1																																																																	
AVAILABLE	NOT APPLICABLE	34566-4463	G	9	B	ST GRV	<table border="1"> <tr><td></td><td></td><td></td><td></td><td></td><td></td><td>63</td><td></td><td></td><td></td><td></td><td></td><td></td><td></td><td></td><td></td><td></td><td></td><td>53</td></tr> <tr><td></td><td></td><td></td><td></td><td></td><td></td><td>48</td><td>47</td><td>45</td><td>43</td><td>42</td><td></td><td>39</td><td></td><td></td><td></td><td></td><td>35</td><td>34</td></tr> <tr><td></td><td></td><td></td><td></td><td></td><td></td><td></td><td></td><td></td><td></td><td>26</td><td></td><td>23</td><td>22</td><td></td><td></td><td></td><td>19</td><td></td></tr> <tr><td>73</td><td></td><td></td><td></td><td></td><td></td><td></td><td></td><td></td><td>11</td><td></td><td></td><td></td><td></td><td></td><td></td><td></td><td></td><td>1</td></tr> </table>							63												53							48	47	45	43	42		39					35	34											26		23	22				19		73									11									1
						63												53																																																																	
						48	47	45	43	42		39					35	34																																																																	
										26		23	22				19																																																																		
73									11									1																																																																	
AVAILABLE	NOT APPLICABLE	34566-4473	G	0	B	ST GRV	<table border="1"> <tr><td></td><td></td><td></td><td></td><td></td><td></td><td>64</td><td>63</td><td>62</td><td></td><td>59</td><td>58</td><td></td><td></td><td></td><td></td><td></td><td></td><td>53</td></tr> <tr><td></td><td></td><td></td><td></td><td></td><td></td><td>47</td><td>45</td><td>43</td><td>42</td><td></td><td>39</td><td></td><td></td><td></td><td></td><td></td><td>35</td><td>34</td></tr> <tr><td></td><td></td><td></td><td></td><td></td><td></td><td></td><td></td><td></td><td>26</td><td>25</td><td>23</td><td>22</td><td></td><td></td><td></td><td></td><td>3</td><td></td></tr> <tr><td>73</td><td></td><td></td><td></td><td></td><td></td><td></td><td></td><td></td><td></td><td></td><td></td><td></td><td></td><td></td><td></td><td></td><td></td><td>1</td></tr> </table>							64	63	62		59	58							53							47	45	43	42		39						35	34										26	25	23	22					3		73																		1
						64	63	62		59	58							53																																																																	
						47	45	43	42		39						35	34																																																																	
									26	25	23	22					3																																																																		
73																		1																																																																	

ENTER DESCRIPTION EEC NO: UAU2016-0232 DRAWN BY: GJ34 CHKD: APPR: IKOSHY 2015/08/14 2015/08/14	QUALITY SYMBOLS	GENERAL TOLERANCES (UNLESS SPECIFIED)	DIMENSION STYLE	SCALE	DESIGN UNITS	THIRD ANGLE PROJECTION
	▽=0	mm INCH	MM ONLY		METRIC	
	▽=0	4 PLACES # --- # ---	DRAWN BY: SKRA JENDRANA	DATE: 2011/02/14	TITLE: MX123	
	▽=0	3 PLACES # --- # ---	CHECKED BY: MYANSLAMBROU	DATE: 2011/02/14	HRNS CONN ASSY	
	ANGULAR ± --- °	DRAFT WHERE APPLICABLE MUST REMAIN WITHIN DIMENSIONS	SEE BOM TABLE	MATERIAL NO. SD-34566-001	DOCUMENT NO.	SHEET NO. 51 OF 85
THIS DRAWING CONTAINS INFORMATION THAT IS PROPRIETARY TO MOLEX INCORPORATED AND SHOULD NOT BE USED WITHOUT WRITTEN PERMISSION						

STATUS	GM PART #	MATERIAL #	PART/MATERIAL REVISION	WIRE DRESS OPTION	KEY OPTION	COLOR (TPA)	NUMBERS INDICATE CAVITIES OPEN FOR CIRCUITS																																																																									
AVAILABLE	NOT APPLICABLE	34566-4483	G	9	C	BLUE	<table border="1"> <tr><td>72</td><td>70</td><td>68</td><td>67</td><td>66</td><td></td><td>63</td><td>62</td><td></td><td>59</td><td>58</td><td>57</td><td>56</td><td>55</td><td>53</td></tr> <tr><td>52</td><td>51</td><td>49</td><td>48</td><td>47</td><td>46</td><td>44</td><td></td><td></td><td>40</td><td>39</td><td>38</td><td>37</td><td>36</td><td>34</td><td>33</td></tr> <tr><td colspan="2">73</td><td>32</td><td>30</td><td></td><td></td><td>27</td><td>26</td><td>25</td><td>24</td><td>23</td><td>22</td><td>21</td><td>20</td><td>19</td><td>18</td><td>17</td></tr> <tr><td></td><td></td><td>15</td><td>14</td><td>13</td><td></td><td></td><td>10</td><td>9</td><td>8</td><td>7</td><td>6</td><td>5</td><td>4</td><td>3</td><td>2</td><td>1</td></tr> </table>	72	70	68	67	66		63	62		59	58	57	56	55	53	52	51	49	48	47	46	44			40	39	38	37	36	34	33	73		32	30			27	26	25	24	23	22	21	20	19	18	17			15	14	13			10	9	8	7	6	5	4	3	2	1								
72	70	68	67	66		63	62		59	58	57	56	55	53																																																																		
52	51	49	48	47	46	44			40	39	38	37	36	34	33																																																																	
73		32	30			27	26	25	24	23	22	21	20	19	18	17																																																																
		15	14	13			10	9	8	7	6	5	4	3	2	1																																																																
AVAILABLE	NOT APPLICABLE	34566-4493	G	9	A	BLACK	<table border="1"> <tr><td>72</td><td>71</td><td>70</td><td>69</td><td>67</td><td></td><td>64</td><td>63</td><td>62</td><td>61</td><td>60</td><td>59</td><td>58</td><td>57</td><td>56</td><td>55</td><td>54</td><td>53</td></tr> <tr><td>52</td><td>51</td><td>50</td><td>49</td><td>48</td><td>47</td><td>45</td><td>44</td><td>43</td><td>42</td><td>41</td><td>40</td><td>39</td><td>38</td><td>37</td><td>36</td><td>34</td><td>33</td></tr> <tr><td colspan="2">73</td><td>32</td><td>30</td><td>29</td><td>28</td><td>27</td><td>26</td><td></td><td>24</td><td>23</td><td></td><td>21</td><td></td><td>19</td><td>18</td><td>17</td></tr> <tr><td></td><td></td><td>16</td><td>15</td><td>14</td><td>13</td><td>12</td><td>11</td><td>10</td><td></td><td>8</td><td></td><td>5</td><td></td><td>3</td><td>2</td><td>1</td></tr> </table>	72	71	70	69	67		64	63	62	61	60	59	58	57	56	55	54	53	52	51	50	49	48	47	45	44	43	42	41	40	39	38	37	36	34	33	73		32	30	29	28	27	26		24	23		21		19	18	17			16	15	14	13	12	11	10		8		5		3	2	1			
72	71	70	69	67		64	63	62	61	60	59	58	57	56	55	54	53																																																															
52	51	50	49	48	47	45	44	43	42	41	40	39	38	37	36	34	33																																																															
73		32	30	29	28	27	26		24	23		21		19	18	17																																																																
		16	15	14	13	12	11	10		8		5		3	2	1																																																																
AVAILABLE	NOT APPLICABLE	34566-4513	G	9	B	ST GRY	<table border="1"> <tr><td>72</td><td>71</td><td>70</td><td>68</td><td>67</td><td>66</td><td></td><td></td><td>62</td><td>61</td><td>60</td><td>59</td><td>58</td><td>57</td><td>56</td><td>55</td><td>54</td><td>53</td></tr> <tr><td>52</td><td>51</td><td>50</td><td>48</td><td>47</td><td>46</td><td></td><td></td><td>42</td><td>41</td><td>40</td><td>39</td><td>38</td><td>37</td><td>36</td><td>35</td><td>34</td><td>33</td></tr> <tr><td colspan="2">73</td><td>32</td><td>31</td><td>30</td><td>29</td><td>28</td><td>27</td><td>26</td><td>25</td><td>24</td><td>23</td><td></td><td></td><td>19</td><td>18</td><td>17</td></tr> <tr><td></td><td></td><td>16</td><td>15</td><td>14</td><td>13</td><td></td><td></td><td>10</td><td></td><td>8</td><td>7</td><td></td><td></td><td>3</td><td>2</td><td>1</td></tr> </table>	72	71	70	68	67	66			62	61	60	59	58	57	56	55	54	53	52	51	50	48	47	46			42	41	40	39	38	37	36	35	34	33	73		32	31	30	29	28	27	26	25	24	23			19	18	17			16	15	14	13			10		8	7			3	2	1			
72	71	70	68	67	66			62	61	60	59	58	57	56	55	54	53																																																															
52	51	50	48	47	46			42	41	40	39	38	37	36	35	34	33																																																															
73		32	31	30	29	28	27	26	25	24	23			19	18	17																																																																
		16	15	14	13			10		8	7			3	2	1																																																																
AVAILABLE	NOT APPLICABLE	34566-4523	G	0	G	BLUE	<table border="1"> <tr><td></td><td>78</td><td>77</td><td>75</td><td>74</td><td>72</td><td>70</td><td>69</td><td>67</td><td>66</td><td>65</td><td>64</td><td>63</td><td>62</td><td></td><td></td><td></td><td></td></tr> <tr><td>60</td><td>58</td><td>57</td><td>55</td><td>54</td><td>52</td><td>51</td><td>50</td><td>49</td><td>47</td><td>45</td><td></td><td></td><td></td><td></td><td></td><td></td><td></td></tr> <tr><td>40</td><td>38</td><td>37</td><td></td><td></td><td></td><td>31</td><td></td><td></td><td>27</td><td>26</td><td>25</td><td>24</td><td></td><td></td><td></td><td></td><td></td></tr> <tr><td>20</td><td>18</td><td>17</td><td></td><td></td><td></td><td></td><td>10</td><td>9</td><td>8</td><td>6</td><td>5</td><td></td><td></td><td>3</td><td>2</td><td>1</td><td></td></tr> </table>		78	77	75	74	72	70	69	67	66	65	64	63	62					60	58	57	55	54	52	51	50	49	47	45								40	38	37				31			27	26	25	24						20	18	17					10	9	8	6	5			3	2	1		
	78	77	75	74	72	70	69	67	66	65	64	63	62																																																																			
60	58	57	55	54	52	51	50	49	47	45																																																																						
40	38	37				31			27	26	25	24																																																																				
20	18	17					10	9	8	6	5			3	2	1																																																																
AVAILABLE	NOT APPLICABLE	34566-4533	G	0	A	BLACK	<table border="1"> <tr><td>72</td><td></td><td>69</td><td>67</td><td>65</td><td>63</td><td></td><td>60</td><td></td><td>57</td><td>56</td><td></td><td></td><td></td><td></td><td></td><td></td><td>53</td></tr> <tr><td></td><td></td><td>49</td><td>47</td><td>44</td><td>43</td><td></td><td>40</td><td></td><td>37</td><td>36</td><td>35</td><td>34</td><td>33</td><td></td><td></td><td></td><td></td></tr> <tr><td colspan="2">73</td><td></td><td>31</td><td>30</td><td>29</td><td>28</td><td></td><td>24</td><td></td><td>21</td><td>20</td><td></td><td></td><td></td><td></td><td></td><td></td></tr> <tr><td></td><td></td><td>16</td><td>15</td><td>14</td><td>13</td><td>11</td><td>10</td><td></td><td></td><td></td><td></td><td></td><td></td><td>5</td><td>4</td><td>3</td><td>2</td><td>1</td></tr> </table>	72		69	67	65	63		60		57	56							53			49	47	44	43		40		37	36	35	34	33					73			31	30	29	28		24		21	20									16	15	14	13	11	10							5	4	3	2	1
72		69	67	65	63		60		57	56							53																																																															
		49	47	44	43		40		37	36	35	34	33																																																																			
73			31	30	29	28		24		21	20																																																																					
		16	15	14	13	11	10							5	4	3	2	1																																																														
AVAILABLE	NOT APPLICABLE	34566-4543	G	0	B	ST GRY	<table border="1"> <tr><td></td><td></td><td></td><td>68</td><td>67</td><td></td><td>64</td><td>63</td><td></td><td></td><td></td><td></td><td>58</td><td>57</td><td>55</td><td>53</td><td></td><td></td></tr> <tr><td></td><td></td><td></td><td>46</td><td>45</td><td>43</td><td></td><td></td><td></td><td></td><td></td><td></td><td>38</td><td>37</td><td>35</td><td></td><td></td><td></td></tr> <tr><td colspan="2">73</td><td></td><td>32</td><td>30</td><td>29</td><td>28</td><td>27</td><td></td><td></td><td></td><td></td><td>22</td><td>21</td><td>19</td><td>17</td><td></td><td></td></tr> <tr><td></td><td></td><td></td><td></td><td></td><td></td><td>12</td><td>10</td><td></td><td></td><td></td><td></td><td></td><td></td><td></td><td></td><td></td><td>1</td></tr> </table>				68	67		64	63					58	57	55	53						46	45	43							38	37	35				73			32	30	29	28	27					22	21	19	17									12	10										1	
			68	67		64	63					58	57	55	53																																																																	
			46	45	43							38	37	35																																																																		
73			32	30	29	28	27					22	21	19	17																																																																	
						12	10										1																																																															
AVAILABLE	NOT APPLICABLE	34566-4553	G	0	B	ST GRY	<table border="1"> <tr><td></td><td></td><td></td><td>68</td><td>67</td><td></td><td>64</td><td>63</td><td></td><td></td><td></td><td></td><td>58</td><td>57</td><td></td><td></td><td></td><td>53</td></tr> <tr><td></td><td></td><td></td><td>46</td><td>45</td><td>43</td><td></td><td></td><td></td><td></td><td></td><td></td><td>38</td><td>37</td><td></td><td></td><td></td><td></td></tr> <tr><td colspan="2">73</td><td></td><td>32</td><td>30</td><td>29</td><td>28</td><td>27</td><td></td><td></td><td></td><td></td><td>22</td><td>21</td><td></td><td></td><td></td><td>17</td></tr> <tr><td></td><td></td><td></td><td></td><td></td><td></td><td>12</td><td>10</td><td></td><td></td><td></td><td></td><td></td><td></td><td></td><td></td><td></td><td></td></tr> </table>				68	67		64	63					58	57				53				46	45	43							38	37					73			32	30	29	28	27					22	21				17							12	10											
			68	67		64	63					58	57				53																																																															
			46	45	43							38	37																																																																			
73			32	30	29	28	27					22	21				17																																																															
						12	10																																																																									
AVAILABLE	NOT APPLICABLE	34566-4563	G	0	B	ST GRY	<table border="1"> <tr><td></td><td></td><td></td><td>68</td><td>67</td><td></td><td>64</td><td>63</td><td></td><td></td><td></td><td></td><td>58</td><td></td><td>55</td><td>53</td><td></td><td></td></tr> <tr><td></td><td></td><td></td><td>46</td><td>45</td><td>43</td><td></td><td></td><td></td><td></td><td></td><td></td><td>38</td><td></td><td>35</td><td></td><td></td><td></td></tr> <tr><td colspan="2">73</td><td></td><td>32</td><td>30</td><td>29</td><td>28</td><td>27</td><td></td><td>10</td><td></td><td></td><td>22</td><td></td><td>19</td><td>17</td><td></td><td></td></tr> <tr><td></td><td></td><td></td><td></td><td></td><td></td><td>12</td><td>10</td><td></td><td></td><td></td><td></td><td></td><td></td><td></td><td></td><td></td><td>1</td></tr> </table>				68	67		64	63					58		55	53						46	45	43							38		35				73			32	30	29	28	27		10			22		19	17									12	10										1	
			68	67		64	63					58		55	53																																																																	
			46	45	43							38		35																																																																		
73			32	30	29	28	27		10			22		19	17																																																																	
						12	10										1																																																															
AVAILABLE	NOT APPLICABLE	34566-4573	G	0	B	ST GRY	<table border="1"> <tr><td></td><td></td><td></td><td>68</td><td>67</td><td></td><td>64</td><td>63</td><td></td><td></td><td></td><td></td><td>58</td><td></td><td></td><td></td><td></td><td>53</td></tr> <tr><td></td><td></td><td></td><td>46</td><td>45</td><td>43</td><td></td><td></td><td></td><td></td><td></td><td></td><td>38</td><td></td><td></td><td></td><td></td><td></td></tr> <tr><td colspan="2">73</td><td></td><td>32</td><td>30</td><td>29</td><td>28</td><td>27</td><td></td><td></td><td></td><td></td><td>22</td><td></td><td></td><td></td><td></td><td>17</td></tr> <tr><td></td><td></td><td></td><td></td><td></td><td></td><td>12</td><td>10</td><td></td><td></td><td></td><td></td><td></td><td></td><td></td><td></td><td></td><td></td></tr> </table>				68	67		64	63					58					53				46	45	43							38						73			32	30	29	28	27					22					17							12	10											
			68	67		64	63					58					53																																																															
			46	45	43							38																																																																				
73			32	30	29	28	27					22					17																																																															
						12	10																																																																									

ENTER DESCRIPTION ELEC NO: UAU2016-0232 DRAWN BY: 2015/08/14 CHKD: 2015/08/14 APPR: IKOSHY	QUALITY SYMBOLS	GENERAL TOLERANCES (UNLESS SPECIFIED)	DIMENSION STYLE	SCALE	DESIGN UNITS	THIRD ANGLE PROJECTION	
	∇=0 ∇=0 ∇=0	4 PLACES ±---+--- INCH 3 PLACES ±---+--- 2 PLACES ±---+--- 1 PLACE ±---+--- 0 PLACE ±---+---	mm INCH	MM ONLY DRAWN BY: SKRAJENDRANA 2011/02/14 CHECKED BY: MYANSLAMBROU 2011/02/14 APPROVED BY:	DATE: 2011/02/14	METRIC	TITLE: MX123 66/73/80CKT HRNS CONN ASSY
	ANGULAR ±---° DRAFT WHERE APPLICABLE MUST REMAIN WITHIN DIMENSIONS	MATERIAL NO. SEE BOM TABLE	DOCUMENT NO. SD-34566-001	SHEET NO. 52 OF 85			
	THIS DRAWING CONTAINS INFORMATION THAT IS PROPRIETARY TO MOLEX INCORPORATED AND SHOULD NOT BE USED WITHOUT WRITTEN PERMISSION						

STATUS	GM PART #	MATERIAL #	PART/ MATERIAL REVISION	WIRE DRESS OPTION	KEY OPTION ▽	COLOR (TPA) ▽	NUMBERS INDICATE CAVITIES OPEN FOR CIRCUITS ▽																																																																																
AVAILABLE	NOT APPLICABLE	34566-4783	G	0	B	ST.GRY	<table border="1"> <tr><td></td><td></td><td></td><td>68</td><td>67</td><td></td><td></td><td>64</td><td>63</td><td></td><td></td><td></td><td></td><td>58</td><td></td><td></td><td>55</td><td></td><td></td></tr> <tr><td></td><td></td><td></td><td></td><td></td><td>46</td><td>45</td><td></td><td>43</td><td></td><td></td><td></td><td></td><td>38</td><td></td><td></td><td>35</td><td></td><td></td></tr> <tr><td>73</td><td></td><td></td><td>32</td><td></td><td>30</td><td>29</td><td>28</td><td>27</td><td></td><td></td><td></td><td></td><td>22</td><td></td><td></td><td>19</td><td></td><td>17</td></tr> <tr><td></td><td></td><td></td><td></td><td>15</td><td></td><td>13</td><td></td><td></td><td>10</td><td></td><td></td><td></td><td>6</td><td></td><td></td><td></td><td></td><td>1</td></tr> </table>				68	67			64	63					58			55								46	45		43					38			35			73			32		30	29	28	27					22			19		17					15		13			10				6					1				
			68	67			64	63					58			55																																																																							
					46	45		43					38			35																																																																							
73			32		30	29	28	27					22			19		17																																																																					
				15		13			10				6					1																																																																					
AVAILABLE	NOT APPLICABLE	34566-4793	G	0	B	ST.GRY	<table border="1"> <tr><td></td><td></td><td></td><td>68</td><td>67</td><td></td><td></td><td>64</td><td>63</td><td></td><td></td><td></td><td></td><td>58</td><td></td><td></td><td></td><td></td><td></td></tr> <tr><td></td><td></td><td></td><td></td><td></td><td>46</td><td>45</td><td></td><td>43</td><td></td><td></td><td></td><td></td><td>38</td><td></td><td></td><td></td><td></td><td></td></tr> <tr><td>73</td><td></td><td></td><td>32</td><td></td><td>30</td><td>29</td><td>28</td><td>27</td><td></td><td></td><td></td><td></td><td>22</td><td></td><td></td><td>19</td><td></td><td>17</td></tr> <tr><td></td><td></td><td></td><td></td><td>15</td><td></td><td>13</td><td></td><td></td><td>10</td><td></td><td></td><td></td><td>6</td><td></td><td></td><td></td><td></td><td></td></tr> </table>				68	67			64	63					58											46	45		43					38						73			32		30	29	28	27					22			19		17					15		13			10				6									
			68	67			64	63					58																																																																										
					46	45		43					38																																																																										
73			32		30	29	28	27					22			19		17																																																																					
				15		13			10				6																																																																										
AVAILABLE	NOT APPLICABLE	34566-4813	G	9	B	ST.GRY	<table border="1"> <tr><td></td><td></td><td></td><td>68</td><td>67</td><td></td><td></td><td>64</td><td></td><td></td><td></td><td></td><td></td><td>59</td><td>58</td><td></td><td></td><td></td><td>54</td></tr> <tr><td></td><td></td><td></td><td></td><td></td><td>46</td><td>45</td><td></td><td></td><td></td><td></td><td></td><td></td><td>39</td><td>38</td><td></td><td></td><td></td><td></td></tr> <tr><td>73</td><td></td><td></td><td>32</td><td></td><td>30</td><td>29</td><td>28</td><td>27</td><td></td><td></td><td></td><td></td><td>23</td><td>22</td><td></td><td></td><td></td><td>17</td></tr> <tr><td></td><td></td><td></td><td></td><td>15</td><td></td><td>13</td><td></td><td></td><td>10</td><td>9</td><td>8</td><td></td><td>6</td><td></td><td></td><td></td><td></td><td>1</td></tr> </table>				68	67			64						59	58				54						46	45							39	38					73			32		30	29	28	27					23	22				17					15		13			10	9	8		6					1				
			68	67			64						59	58				54																																																																					
					46	45							39	38																																																																									
73			32		30	29	28	27					23	22				17																																																																					
				15		13			10	9	8		6					1																																																																					
AVAILABLE	NOT APPLICABLE	34566-4823	G	0	C	BLUE	<table border="1"> <tr><td></td><td></td><td></td><td>68</td><td>67</td><td>66</td><td>65</td><td>64</td><td></td><td></td><td></td><td></td><td></td><td>59</td><td>58</td><td>57</td><td></td><td>55</td><td>54</td><td>53</td></tr> <tr><td>51</td><td>50</td><td>49</td><td>48</td><td></td><td>46</td><td>45</td><td></td><td>43</td><td>42</td><td>41</td><td>40</td><td>39</td><td>38</td><td>37</td><td></td><td>35</td><td></td><td>33</td><td></td></tr> <tr><td>73</td><td></td><td></td><td>32</td><td>31</td><td>30</td><td></td><td></td><td>26</td><td>24</td><td>23</td><td>22</td><td></td><td></td><td></td><td>20</td><td></td><td></td><td></td><td></td></tr> <tr><td></td><td></td><td></td><td></td><td>16</td><td></td><td></td><td></td><td>13</td><td></td><td>10</td><td>9</td><td>8</td><td>7</td><td>6</td><td>5</td><td>4</td><td>3</td><td>2</td><td></td></tr> </table>				68	67	66	65	64						59	58	57		55	54	53	51	50	49	48		46	45		43	42	41	40	39	38	37		35		33		73			32	31	30			26	24	23	22				20									16				13		10	9	8	7	6	5	4	3	2	
			68	67	66	65	64						59	58	57		55	54	53																																																																				
51	50	49	48		46	45		43	42	41	40	39	38	37		35		33																																																																					
73			32	31	30			26	24	23	22				20																																																																								
				16				13		10	9	8	7	6	5	4	3	2																																																																					
AVAILABLE	NOT APPLICABLE	34566-4833	G	0	C	BLUE	<table border="1"> <tr><td>72</td><td>70</td><td></td><td>68</td><td>67</td><td>66</td><td></td><td></td><td>63</td><td>62</td><td></td><td></td><td></td><td>59</td><td></td><td>57</td><td></td><td></td><td></td><td>53</td></tr> <tr><td>52</td><td>51</td><td></td><td>48</td><td>47</td><td>46</td><td></td><td>44</td><td></td><td>42</td><td></td><td></td><td>40</td><td>39</td><td></td><td>37</td><td>36</td><td></td><td>34</td><td>33</td></tr> <tr><td>73</td><td></td><td></td><td>32</td><td></td><td>30</td><td></td><td></td><td>27</td><td>26</td><td>25</td><td>24</td><td></td><td></td><td>22</td><td>21</td><td></td><td></td><td></td><td></td></tr> <tr><td></td><td></td><td></td><td></td><td>15</td><td>14</td><td></td><td></td><td></td><td>10</td><td>9</td><td>8</td><td></td><td></td><td>6</td><td>5</td><td>4</td><td></td><td></td><td>2</td></tr> </table>	72	70		68	67	66			63	62				59		57				53	52	51		48	47	46		44		42			40	39		37	36		34	33	73			32		30			27	26	25	24			22	21									15	14				10	9	8			6	5	4			2
72	70		68	67	66			63	62				59		57				53																																																																				
52	51		48	47	46		44		42			40	39		37	36		34	33																																																																				
73			32		30			27	26	25	24			22	21																																																																								
				15	14				10	9	8			6	5	4			2																																																																				
AVAILABLE	NOT APPLICABLE	34566-4843	G	0	C	BLUE	<table border="1"> <tr><td>72</td><td>70</td><td></td><td>68</td><td>67</td><td>66</td><td></td><td></td><td>63</td><td>62</td><td></td><td></td><td></td><td>59</td><td></td><td>57</td><td></td><td></td><td></td><td>53</td></tr> <tr><td>52</td><td>51</td><td></td><td>48</td><td>47</td><td>46</td><td></td><td>44</td><td></td><td>42</td><td></td><td></td><td>40</td><td>39</td><td>38</td><td>37</td><td>36</td><td></td><td>34</td><td>33</td></tr> <tr><td>73</td><td></td><td></td><td>32</td><td></td><td>30</td><td></td><td></td><td>27</td><td>26</td><td>25</td><td>24</td><td></td><td></td><td>22</td><td>21</td><td></td><td></td><td></td><td></td></tr> <tr><td></td><td></td><td></td><td></td><td>15</td><td>14</td><td></td><td></td><td></td><td>10</td><td>9</td><td>8</td><td></td><td></td><td>6</td><td>5</td><td>4</td><td></td><td></td><td>2</td></tr> </table>	72	70		68	67	66			63	62				59		57				53	52	51		48	47	46		44		42			40	39	38	37	36		34	33	73			32		30			27	26	25	24			22	21									15	14				10	9	8			6	5	4			2
72	70		68	67	66			63	62				59		57				53																																																																				
52	51		48	47	46		44		42			40	39	38	37	36		34	33																																																																				
73			32		30			27	26	25	24			22	21																																																																								
				15	14				10	9	8			6	5	4			2																																																																				
AVAILABLE	NOT APPLICABLE	34566-4853	G	0	C	BLUE	<table border="1"> <tr><td>72</td><td>70</td><td></td><td>68</td><td></td><td>66</td><td></td><td></td><td>63</td><td>62</td><td></td><td></td><td></td><td>59</td><td></td><td>57</td><td>56</td><td>55</td><td></td><td>53</td></tr> <tr><td>52</td><td>51</td><td></td><td>48</td><td>47</td><td>46</td><td></td><td>44</td><td></td><td>42</td><td></td><td></td><td>40</td><td>39</td><td></td><td>37</td><td>36</td><td></td><td>34</td><td>33</td></tr> <tr><td>73</td><td></td><td></td><td>32</td><td></td><td>30</td><td></td><td></td><td>27</td><td>26</td><td>25</td><td>24</td><td></td><td></td><td>22</td><td>21</td><td></td><td></td><td>19</td><td>18</td></tr> <tr><td></td><td></td><td></td><td></td><td>15</td><td>14</td><td></td><td></td><td></td><td>10</td><td>9</td><td>8</td><td></td><td></td><td>6</td><td>5</td><td>4</td><td>3</td><td>2</td><td></td></tr> </table>	72	70		68		66			63	62				59		57	56	55		53	52	51		48	47	46		44		42			40	39		37	36		34	33	73			32		30			27	26	25	24			22	21			19	18					15	14				10	9	8			6	5	4	3	2	
72	70		68		66			63	62				59		57	56	55		53																																																																				
52	51		48	47	46		44		42			40	39		37	36		34	33																																																																				
73			32		30			27	26	25	24			22	21			19	18																																																																				
				15	14				10	9	8			6	5	4	3	2																																																																					
AVAILABLE	NOT APPLICABLE	34566-4863	G	0	C	BLUE	<table border="1"> <tr><td>72</td><td>70</td><td></td><td>68</td><td></td><td>66</td><td></td><td></td><td>63</td><td>62</td><td></td><td></td><td></td><td>59</td><td></td><td>57</td><td></td><td></td><td></td><td>53</td></tr> <tr><td>52</td><td>51</td><td></td><td>48</td><td>47</td><td>46</td><td></td><td>44</td><td></td><td>42</td><td></td><td></td><td>40</td><td>39</td><td>38</td><td>37</td><td>36</td><td></td><td>34</td><td>33</td></tr> <tr><td>73</td><td></td><td></td><td>32</td><td></td><td>30</td><td></td><td></td><td>27</td><td>26</td><td>25</td><td>24</td><td></td><td></td><td>22</td><td>21</td><td></td><td></td><td></td><td></td></tr> <tr><td></td><td></td><td></td><td></td><td>15</td><td>14</td><td></td><td></td><td></td><td>10</td><td>9</td><td>8</td><td></td><td></td><td>6</td><td>5</td><td>4</td><td></td><td></td><td>2</td></tr> </table>	72	70		68		66			63	62				59		57				53	52	51		48	47	46		44		42			40	39	38	37	36		34	33	73			32		30			27	26	25	24			22	21									15	14				10	9	8			6	5	4			2
72	70		68		66			63	62				59		57				53																																																																				
52	51		48	47	46		44		42			40	39	38	37	36		34	33																																																																				
73			32		30			27	26	25	24			22	21																																																																								
				15	14				10	9	8			6	5	4			2																																																																				
AVAILABLE	NOT APPLICABLE	34566-4873	G	0	C	BLUE	<table border="1"> <tr><td>72</td><td>70</td><td></td><td>68</td><td></td><td>66</td><td></td><td></td><td>63</td><td>62</td><td></td><td></td><td></td><td>59</td><td></td><td>57</td><td></td><td></td><td></td><td>53</td></tr> <tr><td>52</td><td>51</td><td></td><td>48</td><td>47</td><td>46</td><td></td><td>44</td><td></td><td>42</td><td></td><td></td><td>40</td><td>39</td><td></td><td>37</td><td>36</td><td></td><td>34</td><td>33</td></tr> <tr><td>73</td><td></td><td></td><td>32</td><td></td><td>30</td><td></td><td></td><td>27</td><td>26</td><td>25</td><td>24</td><td></td><td></td><td>22</td><td>21</td><td></td><td></td><td></td><td></td></tr> <tr><td></td><td></td><td></td><td></td><td>15</td><td>14</td><td></td><td></td><td></td><td>10</td><td>9</td><td>8</td><td></td><td></td><td>6</td><td>5</td><td>4</td><td></td><td></td><td>2</td></tr> </table>	72	70		68		66			63	62				59		57				53	52	51		48	47	46		44		42			40	39		37	36		34	33	73			32		30			27	26	25	24			22	21									15	14				10	9	8			6	5	4			2
72	70		68		66			63	62				59		57				53																																																																				
52	51		48	47	46		44		42			40	39		37	36		34	33																																																																				
73			32		30			27	26	25	24			22	21																																																																								
				15	14				10	9	8			6	5	4			2																																																																				

ENTER DESCRIPTION EC NO: UAU2016-0232 DRAWN BY: 2015/08/14 CHKD: 2015/08/14 APPR: WOSHY REV: G34	QUALITY SYMBOLS ▽=0 ▽=0 ▽=0	GENERAL TOLERANCES (UNLESS SPECIFIED): mm INCH 4 PLACES ± --- ± --- 3 PLACES ± --- ± --- 2 PLACES ± --- ± --- 1 PLACE ± --- ± --- 0 PLACE ± --- ± ---	DIMENSION STYLE MM ONLY	SCALE 1:1	DESIGN UNITS METRIC	THIRD ANGLE PROJECTION 	
	DRAWN BY: SKRAJENDRANA 2011/02/14 CHECKED BY: MVANSLAMBROU 2011/02/14 APPROVED BY:	DATE:	DATE:	DATE:	DATE:	DATE:	TITLE:
	MATERIAL NO.	DOCUMENT NO.	SHEET NO.	MX123 66/73/80CKT HRNS CONN ASSY molex			
	SEE BOM TABLE	SD-34566-001	55 OF 85	THIS DRAWING CONTAINS INFORMATION THAT IS PROPRIETARY TO MOLEX INCORPORATED AND SHOULD NOT BE USED WITHOUT WRITTEN PERMISSION			

STATUS	GM PART #	MATERIAL #	PART/MATERIAL REVISION	WIRE DRESS OPTION	KEY OPTION	COLOR (TFA)	NUMBERS INDICATE CAVITIES OPEN FOR CIRCUITS																																																																											
AVAILABLE	NOT APPLICABLE	34566-4883	G	9	A	BLACK	<table border="1"> <tr><td>72</td><td></td><td>69</td><td>67</td><td>65</td><td>63</td><td></td><td>60</td><td></td><td>57</td><td>56</td><td></td><td>53</td></tr> <tr><td></td><td></td><td>49</td><td>47</td><td>46</td><td>44</td><td>43</td><td></td><td>40</td><td></td><td>37</td><td>36</td><td>35</td><td>33</td></tr> <tr><td></td><td>73</td><td></td><td>31</td><td>30</td><td>29</td><td>28</td><td></td><td>24</td><td></td><td>21</td><td>20</td><td></td><td>17</td></tr> <tr><td></td><td></td><td>16</td><td>15</td><td>14</td><td>13</td><td></td><td>11</td><td>10</td><td></td><td>5</td><td>4</td><td>3</td><td>2</td><td>1</td></tr> </table>	72		69	67	65	63		60		57	56		53			49	47	46	44	43		40		37	36	35	33		73		31	30	29	28		24		21	20		17			16	15	14	13		11	10		5	4	3	2	1																			
72		69	67	65	63		60		57	56		53																																																																						
		49	47	46	44	43		40		37	36	35	33																																																																					
	73		31	30	29	28		24		21	20		17																																																																					
		16	15	14	13		11	10		5	4	3	2	1																																																																				
AVAILABLE	NOT APPLICABLE	34566-4893	G	9	B	ST.GRAY	<table border="1"> <tr><td></td><td></td><td>68</td><td>67</td><td></td><td>64</td><td>63</td><td></td><td></td><td></td><td>58</td><td></td><td>55</td><td></td><td></td></tr> <tr><td></td><td></td><td></td><td>46</td><td>45</td><td>43</td><td></td><td></td><td></td><td></td><td>38</td><td></td><td>35</td><td></td><td></td></tr> <tr><td></td><td>73</td><td>32</td><td></td><td>30</td><td>29</td><td>28</td><td>27</td><td></td><td></td><td>22</td><td></td><td>19</td><td></td><td>17</td></tr> <tr><td></td><td></td><td></td><td>15</td><td>14</td><td>13</td><td></td><td></td><td>10</td><td></td><td></td><td></td><td></td><td></td><td>1</td></tr> </table>			68	67		64	63				58		55						46	45	43					38		35				73	32		30	29	28	27			22		19		17				15	14	13			10						1															
		68	67		64	63				58		55																																																																						
			46	45	43					38		35																																																																						
	73	32		30	29	28	27			22		19		17																																																																				
			15	14	13			10						1																																																																				
AVAILABLE	NOT APPLICABLE	34566-4913	G	9	B	ST.GRAY	<table border="1"> <tr><td></td><td></td><td>68</td><td>67</td><td></td><td>64</td><td>63</td><td></td><td></td><td></td><td>58</td><td>57</td><td>55</td><td>53</td></tr> <tr><td></td><td></td><td></td><td>46</td><td>45</td><td>43</td><td></td><td></td><td></td><td></td><td>38</td><td>37</td><td>35</td><td>33</td></tr> <tr><td></td><td>73</td><td>32</td><td></td><td>30</td><td>29</td><td>28</td><td>27</td><td></td><td></td><td>22</td><td>21</td><td>19</td><td>17</td></tr> <tr><td></td><td></td><td></td><td></td><td></td><td></td><td>12</td><td>10</td><td></td><td></td><td></td><td></td><td></td><td>1</td></tr> </table>			68	67		64	63				58	57	55	53				46	45	43					38	37	35	33		73	32		30	29	28	27			22	21	19	17							12	10						1																			
		68	67		64	63				58	57	55	53																																																																					
			46	45	43					38	37	35	33																																																																					
	73	32		30	29	28	27			22	21	19	17																																																																					
						12	10						1																																																																					
AVAILABLE	NOT APPLICABLE	34566-4923	G	9	A	BLACK	<table border="1"> <tr><td>72</td><td></td><td>69</td><td>67</td><td>65</td><td>63</td><td></td><td>60</td><td></td><td>57</td><td>56</td><td></td><td>53</td></tr> <tr><td></td><td></td><td>49</td><td>47</td><td></td><td>44</td><td>43</td><td></td><td>40</td><td></td><td>37</td><td>36</td><td>35</td><td>33</td></tr> <tr><td></td><td>73</td><td></td><td>31</td><td>30</td><td>29</td><td>28</td><td></td><td></td><td>24</td><td></td><td>21</td><td>20</td><td>17</td></tr> <tr><td></td><td></td><td>16</td><td>15</td><td>14</td><td>13</td><td></td><td>11</td><td>10</td><td></td><td></td><td>5</td><td>4</td><td>3</td><td>2</td><td>1</td></tr> </table>	72		69	67	65	63		60		57	56		53			49	47		44	43		40		37	36	35	33		73		31	30	29	28			24		21	20	17			16	15	14	13		11	10			5	4	3	2	1																		
72		69	67	65	63		60		57	56		53																																																																						
		49	47		44	43		40		37	36	35	33																																																																					
	73		31	30	29	28			24		21	20	17																																																																					
		16	15	14	13		11	10			5	4	3	2	1																																																																			
AVAILABLE	NOT APPLICABLE	34566-4933	G	0	C	BLUE	<table border="1"> <tr><td>72</td><td>70</td><td>68</td><td>67</td><td></td><td>66</td><td>65</td><td>63</td><td>62</td><td></td><td>59</td><td>57</td><td></td><td>53</td></tr> <tr><td>52</td><td>51</td><td></td><td>48</td><td>47</td><td>46</td><td>44</td><td></td><td></td><td></td><td>40</td><td>39</td><td></td><td>37</td><td>36</td><td>35</td><td>34</td><td>33</td></tr> <tr><td></td><td>73</td><td>32</td><td></td><td>30</td><td></td><td></td><td>27</td><td>26</td><td>25</td><td>24</td><td></td><td>22</td><td>21</td><td></td><td></td><td></td><td></td></tr> <tr><td></td><td></td><td></td><td>15</td><td>14</td><td></td><td></td><td></td><td>10</td><td>9</td><td>8</td><td></td><td>6</td><td>5</td><td>4</td><td></td><td></td><td>2</td></tr> </table>	72	70	68	67		66	65	63	62		59	57		53	52	51		48	47	46	44				40	39		37	36	35	34	33		73	32		30			27	26	25	24		22	21								15	14				10	9	8		6	5	4			2							
72	70	68	67		66	65	63	62		59	57		53																																																																					
52	51		48	47	46	44				40	39		37	36	35	34	33																																																																	
	73	32		30			27	26	25	24		22	21																																																																					
			15	14				10	9	8		6	5	4			2																																																																	
AVAILABLE	NOT APPLICABLE	34566-4943	G	0	A	BLACK	<table border="1"> <tr><td></td><td>70</td><td>69</td><td>68</td><td>67</td><td></td><td></td><td>63</td><td>62</td><td>61</td><td>60</td><td>59</td><td>58</td><td>57</td><td>56</td><td>55</td><td>54</td><td>53</td></tr> <tr><td>52</td><td>51</td><td>50</td><td>49</td><td></td><td></td><td></td><td>44</td><td>43</td><td>42</td><td>41</td><td>39</td><td>38</td><td>37</td><td>36</td><td></td><td>34</td><td></td></tr> <tr><td></td><td>73</td><td></td><td>32</td><td>31</td><td></td><td>29</td><td>28</td><td>27</td><td>26</td><td>25</td><td>23</td><td></td><td></td><td></td><td>19</td><td>18</td><td></td></tr> <tr><td></td><td></td><td></td><td>16</td><td>15</td><td>14</td><td>13</td><td>12</td><td>11</td><td>10</td><td>9</td><td>8</td><td></td><td></td><td></td><td>3</td><td></td><td></td></tr> </table>		70	69	68	67			63	62	61	60	59	58	57	56	55	54	53	52	51	50	49				44	43	42	41	39	38	37	36		34			73		32	31		29	28	27	26	25	23				19	18					16	15	14	13	12	11	10	9	8				3					
	70	69	68	67			63	62	61	60	59	58	57	56	55	54	53																																																																	
52	51	50	49				44	43	42	41	39	38	37	36		34																																																																		
	73		32	31		29	28	27	26	25	23				19	18																																																																		
			16	15	14	13	12	11	10	9	8				3																																																																			
AVAILABLE	NOT APPLICABLE	34566-4953	G	0	B	ST.GRAY	<table border="1"> <tr><td>72</td><td>71</td><td>70</td><td>69</td><td>68</td><td>67</td><td>66</td><td>65</td><td>64</td><td>63</td><td></td><td></td><td>59</td><td></td><td></td><td></td><td></td><td>53</td></tr> <tr><td>52</td><td>51</td><td>50</td><td>49</td><td>48</td><td>47</td><td>46</td><td>45</td><td>44</td><td>43</td><td></td><td></td><td>39</td><td></td><td></td><td></td><td></td><td>34</td><td>33</td></tr> <tr><td></td><td>73</td><td></td><td>32</td><td>31</td><td>30</td><td>29</td><td>28</td><td>27</td><td>26</td><td>25</td><td>24</td><td>23</td><td></td><td></td><td></td><td>19</td><td>18</td><td>17</td></tr> <tr><td></td><td></td><td></td><td>16</td><td>15</td><td>14</td><td>13</td><td>12</td><td>11</td><td>10</td><td></td><td>8</td><td>7</td><td></td><td></td><td></td><td>3</td><td>2</td><td>1</td></tr> </table>	72	71	70	69	68	67	66	65	64	63			59					53	52	51	50	49	48	47	46	45	44	43			39					34	33		73		32	31	30	29	28	27	26	25	24	23				19	18	17				16	15	14	13	12	11	10		8	7				3	2	1
72	71	70	69	68	67	66	65	64	63			59					53																																																																	
52	51	50	49	48	47	46	45	44	43			39					34	33																																																																
	73		32	31	30	29	28	27	26	25	24	23				19	18	17																																																																
			16	15	14	13	12	11	10		8	7				3	2	1																																																																
AVAILABLE	NOT APPLICABLE	34566-4963	G	9	A	BLACK	<table border="1"> <tr><td></td><td></td><td>69</td><td>67</td><td>66</td><td>65</td><td></td><td>63</td><td></td><td>60</td><td></td><td>57</td><td>56</td><td></td><td>53</td></tr> <tr><td></td><td></td><td>49</td><td>47</td><td>46</td><td>44</td><td>43</td><td>42</td><td></td><td>40</td><td></td><td>37</td><td>36</td><td>35</td><td>33</td></tr> <tr><td></td><td>73</td><td></td><td>31</td><td>30</td><td>29</td><td>28</td><td>27</td><td>26</td><td>24</td><td></td><td>21</td><td>20</td><td></td><td>17</td></tr> <tr><td></td><td></td><td>16</td><td>15</td><td>14</td><td>13</td><td></td><td>11</td><td>10</td><td></td><td></td><td>5</td><td>4</td><td>3</td><td>2</td><td>1</td></tr> </table>			69	67	66	65		63		60		57	56		53			49	47	46	44	43	42		40		37	36	35	33		73		31	30	29	28	27	26	24		21	20		17			16	15	14	13		11	10			5	4	3	2	1														
		69	67	66	65		63		60		57	56		53																																																																				
		49	47	46	44	43	42		40		37	36	35	33																																																																				
	73		31	30	29	28	27	26	24		21	20		17																																																																				
		16	15	14	13		11	10			5	4	3	2	1																																																																			
AVAILABLE	NOT APPLICABLE	34566-4973	G	9	B	ST.GRAY	<table border="1"> <tr><td></td><td></td><td>68</td><td>67</td><td></td><td>64</td><td>63</td><td></td><td></td><td></td><td>59</td><td>58</td><td></td><td>54</td><td></td></tr> <tr><td></td><td></td><td></td><td>46</td><td>45</td><td>44</td><td>43</td><td></td><td></td><td></td><td>39</td><td>38</td><td></td><td></td><td></td></tr> <tr><td></td><td>73</td><td>32</td><td></td><td>30</td><td>29</td><td>28</td><td>27</td><td></td><td></td><td>23</td><td>22</td><td></td><td></td><td>17</td></tr> <tr><td></td><td></td><td></td><td>15</td><td>14</td><td>13</td><td>12</td><td>10</td><td></td><td></td><td>6</td><td></td><td></td><td></td><td>1</td></tr> </table>			68	67		64	63				59	58		54					46	45	44	43				39	38					73	32		30	29	28	27			23	22			17				15	14	13	12	10			6				1															
		68	67		64	63				59	58		54																																																																					
			46	45	44	43				39	38																																																																							
	73	32		30	29	28	27			23	22			17																																																																				
			15	14	13	12	10			6				1																																																																				

ENTER DESCRIPTION DEC NO. UAU2016-0232 DRAWN BY G34 CHKD: APPR:VKOSHY 2015/08/14	QUALITY SYMBOLS ∇=0 ∇=0 ∇=0	GENERAL TOLERANCES (UNLESS SPECIFIED) <table border="1"> <tr><th></th><th>mm</th><th>INCH</th></tr> <tr><td>4 PLACES</td><td>±---</td><td>±---</td></tr> <tr><td>3 PLACES</td><td>±---</td><td>±---</td></tr> <tr><td>2 PLACES</td><td>±---</td><td>±---</td></tr> <tr><td>1 PLACE</td><td>±---</td><td>±---</td></tr> <tr><td>0 PLACE</td><td>±---</td><td>±---</td></tr> </table>		mm	INCH	4 PLACES	±---	±---	3 PLACES	±---	±---	2 PLACES	±---	±---	1 PLACE	±---	±---	0 PLACE	±---	±---	DIMENSION STYLE MM ONLY	SCALE 1:1	DESIGN UNITS METRIC	THIRD ANGLE PROJECTION
		mm	INCH																					
	4 PLACES	±---	±---																					
	3 PLACES	±---	±---																					
2 PLACES	±---	±---																						
1 PLACE	±---	±---																						
0 PLACE	±---	±---																						
DRAWN BY SKRA JENDRANA 2011/02/14	DATE 2011/02/14	CHECKED BY MVANSLAMBROU 2011/02/14	DATE 2011/02/14	APPROVED BY _____	MATERIAL NO. SD-34566-001	DOCUMENT NO. SD-34566-001																		
ANGULAR ±---° DRAFT WHERE APPLICABLE MUST REMAIN WITHIN DIMENSIONS	SEE BOM TABLE	THIS DRAWING CONTAINS INFORMATION THAT IS PROPRIETARY TO MOLEX INCORPORATED AND SHOULD NOT BE USED WITHOUT WRITTEN PERMISSION	SHEET NO. 56 OF 85																					
MOLEX MX123 66/73/80CKT HRNS CONN ASSY																								

STATUS	GM PART #	MATERIAL #	PART/MATERIAL REVISION	WIRE DRESS OPTION	KEY OPTION	COLOR (TPA)	NUMBERS INDICATE CAVITIES OPEN FOR CIRCUITS																																																																																
AVAILABLE	NOT APPLICABLE	34566-4983	G	0	B	ST.GRAY	<table border="1"> <tr><td>72</td><td>70</td><td>68</td><td>66</td><td></td><td></td><td></td><td>60</td><td>59</td><td></td><td></td><td></td><td>55</td><td>54</td><td>53</td></tr> <tr><td>52</td><td>50</td><td>48</td><td>46</td><td>44</td><td></td><td></td><td>40</td><td>39</td><td></td><td></td><td></td><td>35</td><td>34</td><td>33</td></tr> <tr><td></td><td>73</td><td>32</td><td>31</td><td>30</td><td>29</td><td>28</td><td>27</td><td>26</td><td>25</td><td>24</td><td>23</td><td></td><td>19</td><td>18</td><td>17</td></tr> <tr><td></td><td></td><td>16</td><td></td><td></td><td></td><td></td><td></td><td>10</td><td></td><td>8</td><td>7</td><td></td><td></td><td>2</td><td>1</td></tr> </table>	72	70	68	66				60	59				55	54	53	52	50	48	46	44			40	39				35	34	33		73	32	31	30	29	28	27	26	25	24	23		19	18	17			16						10		8	7			2	1																		
72	70	68	66				60	59				55	54	53																																																																									
52	50	48	46	44			40	39				35	34	33																																																																									
	73	32	31	30	29	28	27	26	25	24	23		19	18	17																																																																								
		16						10		8	7			2	1																																																																								
AVAILABLE	NOT APPLICABLE	34566-4993	G	0	A	BLACK	<table border="1"> <tr><td>72</td><td>71</td><td>70</td><td>69</td><td></td><td>67</td><td></td><td>64</td><td>63</td><td></td><td>60</td><td>59</td><td></td><td>56</td><td>55</td><td>54</td><td>53</td></tr> <tr><td>52</td><td>51</td><td></td><td>49</td><td></td><td>47</td><td></td><td>45</td><td>44</td><td>43</td><td>42</td><td>41</td><td></td><td></td><td>36</td><td>34</td><td></td></tr> <tr><td></td><td></td><td></td><td>73</td><td></td><td>32</td><td></td><td>30</td><td>29</td><td>28</td><td>26</td><td></td><td></td><td></td><td></td><td>19</td><td>18</td></tr> <tr><td></td><td></td><td></td><td></td><td></td><td>16</td><td>15</td><td></td><td></td><td>12</td><td>10</td><td></td><td></td><td></td><td></td><td>3</td><td></td></tr> </table>	72	71	70	69		67		64	63		60	59		56	55	54	53	52	51		49		47		45	44	43	42	41			36	34					73		32		30	29	28	26					19	18						16	15			12	10					3													
72	71	70	69		67		64	63		60	59		56	55	54	53																																																																							
52	51		49		47		45	44	43	42	41			36	34																																																																								
			73		32		30	29	28	26					19	18																																																																							
					16	15			12	10					3																																																																								
AVAILABLE	NOT APPLICABLE	34566-5013	G	9	B	ST.GRAY	<table border="1"> <tr><td></td><td></td><td></td><td>68</td><td>67</td><td></td><td>64</td><td>63</td><td></td><td></td><td>59</td><td>58</td><td></td><td>55</td><td>54</td><td></td></tr> <tr><td></td><td></td><td></td><td></td><td></td><td>46</td><td>45</td><td>44</td><td>43</td><td></td><td>39</td><td>38</td><td></td><td>35</td><td></td><td></td></tr> <tr><td></td><td></td><td></td><td>73</td><td></td><td>32</td><td>30</td><td>29</td><td>28</td><td>27</td><td></td><td>23</td><td>22</td><td></td><td>19</td><td>17</td></tr> <tr><td></td><td></td><td></td><td></td><td></td><td>15</td><td>13</td><td>12</td><td></td><td>10</td><td></td><td>6</td><td></td><td></td><td></td><td>1</td></tr> </table>				68	67		64	63			59	58		55	54							46	45	44	43		39	38		35						73		32	30	29	28	27		23	22		19	17						15	13	12		10		6				1																
			68	67		64	63			59	58		55	54																																																																									
					46	45	44	43		39	38		35																																																																										
			73		32	30	29	28	27		23	22		19	17																																																																								
					15	13	12		10		6				1																																																																								
AVAILABLE	NOT APPLICABLE	34566-5023	G	0	C	BLUE	<table border="1"> <tr><td>72</td><td>70</td><td>68</td><td>67</td><td></td><td></td><td>63</td><td>62</td><td></td><td>59</td><td>57</td><td></td><td></td><td></td><td>53</td></tr> <tr><td>52</td><td>51</td><td></td><td>48</td><td>47</td><td>46</td><td>44</td><td>42</td><td>40</td><td>39</td><td>37</td><td>36</td><td></td><td>34</td><td>33</td></tr> <tr><td></td><td>73</td><td></td><td>32</td><td>30</td><td></td><td></td><td>26</td><td>25</td><td>24</td><td>22</td><td>21</td><td>20</td><td></td><td></td></tr> <tr><td></td><td></td><td></td><td>15</td><td>14</td><td></td><td></td><td></td><td>8</td><td>6</td><td>5</td><td>4</td><td></td><td></td><td>2</td></tr> </table>	72	70	68	67			63	62		59	57				53	52	51		48	47	46	44	42	40	39	37	36		34	33		73		32	30			26	25	24	22	21	20						15	14				8	6	5	4			2																				
72	70	68	67			63	62		59	57				53																																																																									
52	51		48	47	46	44	42	40	39	37	36		34	33																																																																									
	73		32	30			26	25	24	22	21	20																																																																											
			15	14				8	6	5	4			2																																																																									
AVAILABLE	NOT APPLICABLE	34566-5033	G	0	A	BLACK	<table border="1"> <tr><td></td><td>70</td><td>69</td><td></td><td></td><td></td><td>63</td><td>62</td><td>61</td><td>60</td><td></td><td>58</td><td>57</td><td>56</td><td>55</td><td>54</td><td>53</td></tr> <tr><td>52</td><td>51</td><td></td><td>49</td><td></td><td></td><td>44</td><td>43</td><td>42</td><td>41</td><td></td><td></td><td>37</td><td>36</td><td>35</td><td>34</td><td>33</td></tr> <tr><td></td><td></td><td></td><td>73</td><td></td><td></td><td>32</td><td></td><td>29</td><td>28</td><td>27</td><td>26</td><td>25</td><td></td><td></td><td>19</td><td>18</td></tr> <tr><td></td><td></td><td></td><td></td><td></td><td>16</td><td>15</td><td></td><td>13</td><td>12</td><td>11</td><td>10</td><td></td><td></td><td></td><td>3</td><td></td></tr> </table>		70	69				63	62	61	60		58	57	56	55	54	53	52	51		49			44	43	42	41			37	36	35	34	33				73			32		29	28	27	26	25			19	18						16	15		13	12	11	10				3													
	70	69				63	62	61	60		58	57	56	55	54	53																																																																							
52	51		49			44	43	42	41			37	36	35	34	33																																																																							
			73			32		29	28	27	26	25			19	18																																																																							
					16	15		13	12	11	10				3																																																																								
AVAILABLE	NOT APPLICABLE	34566-5043	G	0	A	BLACK	<table border="1"> <tr><td></td><td></td><td></td><td></td><td></td><td></td><td></td><td></td><td></td><td></td><td></td><td></td><td></td><td></td><td></td><td></td><td></td></tr> <tr><td></td><td></td><td></td><td></td><td></td><td></td><td></td><td></td><td></td><td></td><td></td><td></td><td></td><td></td><td></td><td></td><td></td></tr> <tr><td></td><td></td><td></td><td>73</td><td></td><td></td><td>31</td><td></td><td></td><td></td><td></td><td></td><td></td><td></td><td></td><td></td><td></td></tr> </table>																																						73			31																																							
			73			31																																																																																	
AVAILABLE	NOT APPLICABLE	34566-5053	G	0	B	ST.GRAY	<table border="1"> <tr><td></td><td></td><td></td><td></td><td></td><td></td><td></td><td></td><td></td><td></td><td></td><td></td><td></td><td></td><td></td><td></td><td></td></tr> <tr><td></td><td></td><td></td><td></td><td></td><td></td><td></td><td></td><td></td><td></td><td></td><td></td><td></td><td></td><td></td><td></td><td></td></tr> <tr><td></td><td></td><td></td><td>73</td><td></td><td></td><td>47</td><td></td><td></td><td></td><td></td><td></td><td></td><td></td><td></td><td>20</td><td>17</td></tr> <tr><td></td><td></td><td></td><td></td><td></td><td></td><td>31</td><td></td><td></td><td></td><td></td><td></td><td></td><td></td><td></td><td></td><td>1</td></tr> </table>																																						73			47									20	17							31										1												
			73			47									20	17																																																																							
						31										1																																																																							
AVAILABLE	NOT APPLICABLE	34566-5063	G	9	H	ST.GRAY	<table border="1"> <tr><td>80</td><td>79</td><td>78</td><td>77</td><td>76</td><td>75</td><td>74</td><td>73</td><td>72</td><td>71</td><td>70</td><td>69</td><td>68</td><td>67</td><td>66</td><td>65</td><td>64</td><td>63</td><td>62</td><td>61</td></tr> <tr><td>60</td><td>59</td><td>58</td><td>57</td><td>56</td><td>55</td><td>54</td><td>53</td><td>52</td><td>51</td><td>50</td><td>49</td><td>48</td><td>47</td><td>46</td><td>45</td><td>44</td><td>43</td><td>42</td><td>41</td></tr> <tr><td>40</td><td>39</td><td>38</td><td>37</td><td></td><td>35</td><td>34</td><td>33</td><td>32</td><td>30</td><td>29</td><td>27</td><td>26</td><td></td><td>24</td><td>23</td><td>22</td><td>21</td><td></td><td></td></tr> <tr><td>20</td><td>19</td><td>18</td><td>17</td><td></td><td></td><td>14</td><td>13</td><td>12</td><td>11</td><td>10</td><td>9</td><td>8</td><td></td><td>6</td><td>5</td><td></td><td>3</td><td>2</td><td></td></tr> </table>	80	79	78	77	76	75	74	73	72	71	70	69	68	67	66	65	64	63	62	61	60	59	58	57	56	55	54	53	52	51	50	49	48	47	46	45	44	43	42	41	40	39	38	37		35	34	33	32	30	29	27	26		24	23	22	21			20	19	18	17			14	13	12	11	10	9	8		6	5		3	2	
80	79	78	77	76	75	74	73	72	71	70	69	68	67	66	65	64	63	62	61																																																																				
60	59	58	57	56	55	54	53	52	51	50	49	48	47	46	45	44	43	42	41																																																																				
40	39	38	37		35	34	33	32	30	29	27	26		24	23	22	21																																																																						
20	19	18	17			14	13	12	11	10	9	8		6	5		3	2																																																																					
AVAILABLE	NOT APPLICABLE	34566-5073	G	9	A	BLACK	<table border="1"> <tr><td>72</td><td>71</td><td>70</td><td>69</td><td>68</td><td>67</td><td>66</td><td>65</td><td>64</td><td>63</td><td>62</td><td>61</td><td>60</td><td>59</td><td>58</td><td>57</td><td>56</td><td>55</td><td>54</td><td>53</td></tr> <tr><td>52</td><td>51</td><td>50</td><td>49</td><td>48</td><td>47</td><td>46</td><td>45</td><td>44</td><td>43</td><td>42</td><td>41</td><td>40</td><td>39</td><td>38</td><td>37</td><td>36</td><td></td><td>34</td><td>33</td></tr> <tr><td></td><td></td><td>73</td><td></td><td>32</td><td>31</td><td>30</td><td>29</td><td>28</td><td>27</td><td>26</td><td></td><td>24</td><td>23</td><td>22</td><td>21</td><td>20</td><td>19</td><td>18</td><td></td></tr> <tr><td></td><td></td><td></td><td></td><td>16</td><td></td><td></td><td>13</td><td>12</td><td>11</td><td>10</td><td>9</td><td>8</td><td></td><td></td><td></td><td></td><td></td><td></td><td>1</td></tr> </table>	72	71	70	69	68	67	66	65	64	63	62	61	60	59	58	57	56	55	54	53	52	51	50	49	48	47	46	45	44	43	42	41	40	39	38	37	36		34	33			73		32	31	30	29	28	27	26		24	23	22	21	20	19	18						16			13	12	11	10	9	8							1
72	71	70	69	68	67	66	65	64	63	62	61	60	59	58	57	56	55	54	53																																																																				
52	51	50	49	48	47	46	45	44	43	42	41	40	39	38	37	36		34	33																																																																				
		73		32	31	30	29	28	27	26		24	23	22	21	20	19	18																																																																					
				16			13	12	11	10	9	8							1																																																																				

ENTER DESCRIPTION DEC NO: JAU2016-0232 DRAWN BY: GJ34 CHKD: GJ34 APPR: WJOSHY 2015/08/14 2015/08/14 DESCRIPTION	QUALITY SYMBOLS	GENERAL TOLERANCES (UNLESS SPECIFIED)	DIMENSION STYLE	SCALE	DESIGN UNITS	THIRD ANGLE PROJECTION
	▽=0	mm INCH	MM ONLY	1:1	METRIC	☉
	▽=0	4 PLACES #--- #---	DRAWN BY DATE			
	▽=0	3 PLACES #--- #---	SKRA JENDRANA 2011/02/14			
	2 PLACES #--- #---	CHECKED BY DATE				
	1 PLACE #--- #---	MVANS LAMBROU 2011/02/14				
	0 PLACE #--- #---	APPROVED BY DATE				
	ANGULAR ±---	MATERIAL NO.	DOCUMENT NO.			
	DRAFT WHERE APPLICABLE MUST REMAIN WITHIN DIMENSIONS	SEE BOM TABLE	SD-34566-001			
		SIZE D				

MX123
66/73/80CKT
HRNS CONN ASSY
molex

SHEET NO. 57 OF 85

STATUS	GM PART #	MATERIAL #	PART/MATERIAL REVISION	WIRE DRESS OPTION	KEY OPTION	COLOR (TPA)	NUMBERS INDICATE CAVITIES OPEN FOR CIRCUITS																																																																																		
AVAILABLE	NOT APPLICABLE	34566-5183	G	0	B	ST.GRAY	<table border="1"> <tr><td></td><td></td><td></td><td>68</td><td>67</td><td></td><td>64</td><td></td><td></td><td></td><td>59</td><td>58</td><td></td><td></td><td>54</td></tr> <tr><td></td><td></td><td></td><td></td><td></td><td>46</td><td>45</td><td>44</td><td></td><td></td><td>39</td><td>38</td><td></td><td></td><td></td></tr> <tr><td></td><td>73</td><td></td><td>32</td><td></td><td>30</td><td>29</td><td>28</td><td>27</td><td></td><td>23</td><td>22</td><td></td><td></td><td>17</td></tr> <tr><td></td><td></td><td></td><td></td><td></td><td></td><td></td><td>12</td><td></td><td>10</td><td>8</td><td></td><td></td><td></td><td>1</td></tr> </table>				68	67		64				59	58			54						46	45	44			39	38					73		32		30	29	28	27		23	22			17								12		10	8				1																						
			68	67		64				59	58			54																																																																											
					46	45	44			39	38																																																																														
	73		32		30	29	28	27		23	22			17																																																																											
							12		10	8				1																																																																											
AVAILABLE	NOT APPLICABLE	34566-5193	G	0	A	BLACK	<table border="1"> <tr><td></td><td></td><td>70</td><td>69</td><td></td><td></td><td></td><td></td><td>63</td><td>62</td><td>61</td><td>60</td><td></td><td>58</td><td>57</td><td>56</td><td>55</td><td>54</td><td>53</td></tr> <tr><td>52</td><td>51</td><td></td><td>49</td><td></td><td></td><td></td><td></td><td>44</td><td>43</td><td>42</td><td>41</td><td></td><td></td><td>37</td><td>36</td><td></td><td>34</td><td></td></tr> <tr><td></td><td></td><td></td><td></td><td>32</td><td></td><td></td><td>29</td><td>28</td><td>27</td><td>26</td><td></td><td></td><td></td><td></td><td></td><td>19</td><td>18</td><td>17</td></tr> <tr><td></td><td>73</td><td></td><td></td><td>16</td><td>15</td><td></td><td>13</td><td>12</td><td>11</td><td>10</td><td></td><td></td><td></td><td></td><td></td><td>3</td><td>2</td><td>1</td></tr> </table>			70	69					63	62	61	60		58	57	56	55	54	53	52	51		49					44	43	42	41			37	36		34						32			29	28	27	26						19	18	17		73			16	15		13	12	11	10						3	2	1						
		70	69					63	62	61	60		58	57	56	55	54	53																																																																							
52	51		49					44	43	42	41			37	36		34																																																																								
				32			29	28	27	26						19	18	17																																																																							
	73			16	15		13	12	11	10						3	2	1																																																																							
AVAILABLE	NOT APPLICABLE	34566-5213	G	0	A	BLACK	<table border="1"> <tr><td>72</td><td>71</td><td>70</td><td>69</td><td>68</td><td>67</td><td>66</td><td>65</td><td>64</td><td>63</td><td>62</td><td>61</td><td>60</td><td>59</td><td></td><td></td><td>55</td><td>54</td><td>53</td></tr> <tr><td>52</td><td></td><td></td><td>49</td><td>48</td><td></td><td></td><td></td><td>44</td><td>43</td><td>42</td><td>41</td><td>40</td><td>39</td><td></td><td></td><td>35</td><td>34</td><td>33</td></tr> <tr><td></td><td></td><td></td><td></td><td>32</td><td></td><td></td><td>29</td><td>28</td><td>27</td><td>26</td><td>25</td><td>24</td><td>23</td><td></td><td></td><td>19</td><td>18</td><td>17</td></tr> <tr><td></td><td>73</td><td></td><td></td><td>16</td><td></td><td></td><td>13</td><td>12</td><td>11</td><td></td><td>9</td><td>8</td><td>7</td><td>6</td><td>5</td><td>4</td><td>3</td><td>2</td><td>1</td></tr> </table>	72	71	70	69	68	67	66	65	64	63	62	61	60	59			55	54	53	52			49	48				44	43	42	41	40	39			35	34	33					32			29	28	27	26	25	24	23			19	18	17		73			16			13	12	11		9	8	7	6	5	4	3	2	1					
72	71	70	69	68	67	66	65	64	63	62	61	60	59			55	54	53																																																																							
52			49	48				44	43	42	41	40	39			35	34	33																																																																							
				32			29	28	27	26	25	24	23			19	18	17																																																																							
	73			16			13	12	11		9	8	7	6	5	4	3	2	1																																																																						
AVAILABLE	NOT APPLICABLE	34566-5223	G	0	C	BLUE	<table border="1"> <tr><td>72</td><td>70</td><td></td><td></td><td>67</td><td>66</td><td></td><td></td><td>63</td><td>62</td><td></td><td></td><td>59</td><td></td><td>57</td><td></td><td></td><td></td><td>53</td></tr> <tr><td>52</td><td>51</td><td></td><td></td><td>48</td><td>46</td><td></td><td>44</td><td></td><td>42</td><td></td><td>40</td><td>39</td><td></td><td></td><td></td><td></td><td>34</td><td>33</td></tr> <tr><td></td><td></td><td></td><td></td><td>32</td><td>30</td><td></td><td></td><td>27</td><td>26</td><td>25</td><td></td><td></td><td>22</td><td>21</td><td></td><td></td><td></td><td></td></tr> <tr><td></td><td>73</td><td></td><td></td><td>15</td><td>14</td><td></td><td></td><td></td><td>10</td><td>9</td><td></td><td></td><td>6</td><td>5</td><td>4</td><td></td><td></td><td></td></tr> </table>	72	70			67	66			63	62			59		57				53	52	51			48	46		44		42		40	39					34	33					32	30			27	26	25			22	21						73			15	14				10	9			6	5	4									
72	70			67	66			63	62			59		57				53																																																																							
52	51			48	46		44		42		40	39					34	33																																																																							
				32	30			27	26	25			22	21																																																																											
	73			15	14				10	9			6	5	4																																																																										
AVAILABLE	NOT APPLICABLE	34566-5233	G	0	C	BLUE	<table border="1"> <tr><td>72</td><td>70</td><td></td><td></td><td>68</td><td>67</td><td>66</td><td></td><td>63</td><td>62</td><td></td><td></td><td>59</td><td></td><td>57</td><td>56</td><td>55</td><td>54</td><td>53</td></tr> <tr><td>52</td><td>51</td><td></td><td></td><td>48</td><td>47</td><td>46</td><td></td><td>44</td><td></td><td>42</td><td>40</td><td>39</td><td>38</td><td></td><td></td><td></td><td>34</td><td>33</td></tr> <tr><td></td><td></td><td></td><td></td><td>32</td><td></td><td>30</td><td></td><td></td><td>26</td><td>25</td><td></td><td></td><td>22</td><td>21</td><td></td><td>19</td><td>18</td><td></td></tr> <tr><td></td><td>73</td><td></td><td></td><td>15</td><td>14</td><td></td><td></td><td></td><td>10</td><td>9</td><td></td><td></td><td>6</td><td>5</td><td>4</td><td>3</td><td></td><td></td></tr> </table>	72	70			68	67	66		63	62			59		57	56	55	54	53	52	51			48	47	46		44		42	40	39	38				34	33					32		30			26	25			22	21		19	18			73			15	14				10	9			6	5	4	3								
72	70			68	67	66		63	62			59		57	56	55	54	53																																																																							
52	51			48	47	46		44		42	40	39	38				34	33																																																																							
				32		30			26	25			22	21		19	18																																																																								
	73			15	14				10	9			6	5	4	3																																																																									
AVAILABLE	NOT APPLICABLE	34566-5243	G	0	C	BLUE	<table border="1"> <tr><td>72</td><td>71</td><td>70</td><td>69</td><td>68</td><td>67</td><td>66</td><td>65</td><td>64</td><td>63</td><td>62</td><td>61</td><td>60</td><td>59</td><td>58</td><td>57</td><td>56</td><td>55</td><td>54</td><td>53</td></tr> <tr><td>51</td><td>50</td><td>49</td><td>48</td><td></td><td></td><td>46</td><td>45</td><td>44</td><td>43</td><td>42</td><td>41</td><td>40</td><td>39</td><td>38</td><td></td><td>36</td><td>35</td><td>34</td><td>33</td></tr> <tr><td></td><td></td><td></td><td></td><td></td><td></td><td>31</td><td>30</td><td>29</td><td>28</td><td>27</td><td>26</td><td>25</td><td></td><td></td><td>22</td><td>21</td><td>20</td><td>19</td><td>18</td><td>17</td></tr> <tr><td></td><td>73</td><td></td><td></td><td></td><td></td><td>16</td><td>15</td><td>14</td><td></td><td></td><td></td><td>9</td><td>7</td><td>6</td><td>5</td><td>4</td><td>3</td><td>2</td><td>1</td><td></td></tr> </table>	72	71	70	69	68	67	66	65	64	63	62	61	60	59	58	57	56	55	54	53	51	50	49	48			46	45	44	43	42	41	40	39	38		36	35	34	33							31	30	29	28	27	26	25			22	21	20	19	18	17		73					16	15	14				9	7	6	5	4	3	2	1	
72	71	70	69	68	67	66	65	64	63	62	61	60	59	58	57	56	55	54	53																																																																						
51	50	49	48			46	45	44	43	42	41	40	39	38		36	35	34	33																																																																						
						31	30	29	28	27	26	25			22	21	20	19	18	17																																																																					
	73					16	15	14				9	7	6	5	4	3	2	1																																																																						
AVAILABLE	NOT APPLICABLE	34566-5253	G	0	B	ST.GRAY	<table border="1"> <tr><td></td><td></td><td></td><td></td><td></td><td>67</td><td>66</td><td></td><td></td><td>63</td><td></td><td></td><td></td><td>59</td><td>58</td><td>57</td><td>56</td><td>55</td><td>54</td><td>53</td></tr> <tr><td></td><td></td><td>50</td><td>49</td><td>48</td><td></td><td>46</td><td>45</td><td>44</td><td>43</td><td></td><td></td><td></td><td>39</td><td>38</td><td>37</td><td>36</td><td>35</td><td>34</td><td>33</td></tr> <tr><td></td><td></td><td></td><td></td><td></td><td></td><td></td><td></td><td>29</td><td>27</td><td></td><td></td><td></td><td>23</td><td>22</td><td>21</td><td></td><td></td><td></td><td>18</td></tr> <tr><td></td><td>73</td><td></td><td></td><td></td><td></td><td>16</td><td>15</td><td>14</td><td>13</td><td></td><td></td><td></td><td>8</td><td>7</td><td>6</td><td>5</td><td>4</td><td>3</td><td></td><td></td></tr> </table>						67	66			63				59	58	57	56	55	54	53			50	49	48		46	45	44	43				39	38	37	36	35	34	33									29	27				23	22	21				18		73					16	15	14	13				8	7	6	5	4	3			
					67	66			63				59	58	57	56	55	54	53																																																																						
		50	49	48		46	45	44	43				39	38	37	36	35	34	33																																																																						
								29	27				23	22	21				18																																																																						
	73					16	15	14	13				8	7	6	5	4	3																																																																							
AVAILABLE	NOT APPLICABLE	34566-5263	G	0	B	ST.GRAY	<table border="1"> <tr><td>72</td><td>71</td><td>70</td><td></td><td>68</td><td>67</td><td>66</td><td></td><td></td><td></td><td>62</td><td>61</td><td>60</td><td>59</td><td>58</td><td>57</td><td>56</td><td>55</td><td>54</td><td>53</td></tr> <tr><td>52</td><td>51</td><td>50</td><td></td><td>48</td><td>47</td><td>46</td><td></td><td></td><td></td><td>42</td><td>41</td><td>40</td><td>39</td><td>38</td><td>37</td><td>36</td><td>35</td><td>34</td><td>33</td></tr> <tr><td></td><td></td><td></td><td></td><td>32</td><td>31</td><td>30</td><td>29</td><td>28</td><td>27</td><td></td><td>25</td><td>24</td><td></td><td></td><td></td><td></td><td></td><td></td><td>17</td></tr> <tr><td></td><td>73</td><td></td><td></td><td>16</td><td>15</td><td>14</td><td>13</td><td></td><td></td><td>10</td><td>8</td><td></td><td></td><td></td><td></td><td></td><td></td><td></td><td>2</td><td>1</td></tr> </table>	72	71	70		68	67	66				62	61	60	59	58	57	56	55	54	53	52	51	50		48	47	46				42	41	40	39	38	37	36	35	34	33					32	31	30	29	28	27		25	24							17		73			16	15	14	13			10	8								2	1	
72	71	70		68	67	66				62	61	60	59	58	57	56	55	54	53																																																																						
52	51	50		48	47	46				42	41	40	39	38	37	36	35	34	33																																																																						
				32	31	30	29	28	27		25	24							17																																																																						
	73			16	15	14	13			10	8								2	1																																																																					
AVAILABLE	NOT APPLICABLE	34566-5273	G	0	A	BLACK	<table border="1"> <tr><td></td><td></td><td>70</td><td>69</td><td></td><td></td><td></td><td></td><td></td><td>63</td><td>62</td><td>61</td><td>60</td><td></td><td>58</td><td>57</td><td>56</td><td>55</td><td>54</td><td>53</td></tr> <tr><td>52</td><td>51</td><td></td><td>49</td><td></td><td></td><td></td><td></td><td></td><td>44</td><td>43</td><td>42</td><td>41</td><td></td><td></td><td>37</td><td>36</td><td></td><td>34</td><td></td></tr> <tr><td></td><td></td><td></td><td></td><td>32</td><td></td><td></td><td></td><td>29</td><td>28</td><td>27</td><td>26</td><td></td><td></td><td>23</td><td></td><td></td><td></td><td>19</td><td>18</td></tr> <tr><td></td><td>73</td><td></td><td></td><td>16</td><td>15</td><td></td><td></td><td>13</td><td>12</td><td>11</td><td>10</td><td>9</td><td>8</td><td></td><td></td><td></td><td></td><td>3</td><td></td><td></td></tr> </table>			70	69						63	62	61	60		58	57	56	55	54	53	52	51		49						44	43	42	41			37	36		34						32				29	28	27	26			23				19	18		73			16	15			13	12	11	10	9	8					3			
		70	69						63	62	61	60		58	57	56	55	54	53																																																																						
52	51		49						44	43	42	41			37	36		34																																																																							
				32				29	28	27	26			23				19	18																																																																						
	73			16	15			13	12	11	10	9	8					3																																																																							

ENTER DESCRIPTION DEC NO. UAU2016-0232 DRAWN BY G34 CHKD: APPR:VKOSHY 2015/08/14	QUALITY SYMBOLS	GENERAL TOLERANCES (UNLESS SPECIFIED)	DIMENSION STYLE	SCALE	DESIGN UNITS	THIRD ANGLE PROJECTION	
	∇=0 ∇=0 ∇=0	mm INCH 4 PLACES ± --- ± --- 3 PLACES ± --- ± --- 2 PLACES ± --- ± --- 1 PLACE ± --- ± --- 0 PLACE ± --- ± ---	MM ONLY	1:1	METRIC	DRAWN BY DATE SKRA JENDRANA 2011/02/14 CHECKED BY DATE MVANSLAMBROU 2011/02/14 APPROVED BY DATE	
	ANGULAR ± --- DRAFT WHERE APPLICABLE MUST REMAIN WITHIN DIMENSIONS	MATERIAL NO.	DOCUMENT NO.	SHEET NO.	MX123 66/73/80CKT HRNS CONN ASSY molex SD-34566-001 59 OF 85		
	SIZE D THIS DRAWING CONTAINS INFORMATION THAT IS PROPRIETARY TO MOLEX INCORPORATED AND SHOULD NOT BE USED WITHOUT WRITTEN PERMISSION	SEE BOM	SD-34566-001	59 OF 85			

STATUS	GM PART #	MATERIAL #	PART/MATERIAL REVISION	WIRE DRESS OPTION	KEY OPTION Fp	COLOR (TPA) Fp	NUMBERS INDICATE CAVITIES OPEN FOR CIRCUITS Fp																																																																				
AVAILABLE	NOT APPLICABLE	34566-5283	G	0	C	BLUE	<table border="1"> <tr><td>72</td><td>70</td><td>68</td><td>67</td><td>66</td><td></td><td>63</td><td>62</td><td></td><td>59</td><td>57</td><td>56</td><td>55</td><td>54</td><td>53</td></tr> <tr><td>52</td><td>51</td><td></td><td>48</td><td>47</td><td>46</td><td>44</td><td>42</td><td></td><td>40</td><td>39</td><td></td><td></td><td>34</td><td>33</td></tr> <tr><td></td><td>73</td><td></td><td></td><td>32</td><td>30</td><td></td><td></td><td>26</td><td>25</td><td></td><td>22</td><td>21</td><td>19</td><td>18</td></tr> <tr><td></td><td></td><td></td><td></td><td>15</td><td>14</td><td></td><td></td><td>10</td><td>9</td><td></td><td>6</td><td>5</td><td>4</td><td>3</td></tr> </table>	72	70	68	67	66		63	62		59	57	56	55	54	53	52	51		48	47	46	44	42		40	39			34	33		73			32	30			26	25		22	21	19	18					15	14			10	9		6	5	4	3								
72	70	68	67	66		63	62		59	57	56	55	54	53																																																													
52	51		48	47	46	44	42		40	39			34	33																																																													
	73			32	30			26	25		22	21	19	18																																																													
				15	14			10	9		6	5	4	3																																																													
AVAILABLE	NOT APPLICABLE	34566-5293	G	0	A	BLACK	<table border="1"> <tr><td></td><td>70</td><td>69</td><td></td><td></td><td></td><td>63</td><td>62</td><td>61</td><td>60</td><td></td><td>58</td><td>57</td><td>56</td><td>55</td><td>54</td><td>53</td></tr> <tr><td>52</td><td>51</td><td>49</td><td></td><td></td><td></td><td>44</td><td>43</td><td>42</td><td>41</td><td>40</td><td></td><td></td><td>37</td><td>36</td><td>34</td><td></td></tr> <tr><td></td><td>73</td><td></td><td>32</td><td></td><td>29</td><td>28</td><td>27</td><td>26</td><td></td><td></td><td></td><td></td><td></td><td>19</td><td>18</td><td>17</td></tr> <tr><td></td><td></td><td></td><td>16</td><td>15</td><td>13</td><td>12</td><td>11</td><td>10</td><td></td><td></td><td></td><td></td><td></td><td>3</td><td>2</td><td>1</td></tr> </table>		70	69				63	62	61	60		58	57	56	55	54	53	52	51	49				44	43	42	41	40			37	36	34			73		32		29	28	27	26						19	18	17				16	15	13	12	11	10						3	2	1
	70	69				63	62	61	60		58	57	56	55	54	53																																																											
52	51	49				44	43	42	41	40			37	36	34																																																												
	73		32		29	28	27	26						19	18	17																																																											
			16	15	13	12	11	10						3	2	1																																																											
AVAILABLE	NOT APPLICABLE	34566-5313	G	0	C	BLUE	<table border="1"> <tr><td>72</td><td>70</td><td>68</td><td>67</td><td>66</td><td></td><td>63</td><td>62</td><td></td><td>59</td><td>57</td><td>56</td><td>55</td><td>54</td><td>53</td></tr> <tr><td>52</td><td>51</td><td></td><td>48</td><td>47</td><td>46</td><td>44</td><td>42</td><td></td><td>40</td><td>39</td><td>38</td><td>37</td><td>36</td><td>34</td><td>33</td></tr> <tr><td></td><td>73</td><td></td><td>32</td><td>30</td><td></td><td>27</td><td>26</td><td>25</td><td>24</td><td></td><td>22</td><td>21</td><td>19</td><td>18</td></tr> <tr><td></td><td></td><td></td><td>15</td><td>14</td><td></td><td></td><td>10</td><td>9</td><td>8</td><td></td><td>6</td><td>5</td><td>4</td><td>3</td><td>2</td></tr> </table>	72	70	68	67	66		63	62		59	57	56	55	54	53	52	51		48	47	46	44	42		40	39	38	37	36	34	33		73		32	30		27	26	25	24		22	21	19	18				15	14			10	9	8		6	5	4	3	2						
72	70	68	67	66		63	62		59	57	56	55	54	53																																																													
52	51		48	47	46	44	42		40	39	38	37	36	34	33																																																												
	73		32	30		27	26	25	24		22	21	19	18																																																													
			15	14			10	9	8		6	5	4	3	2																																																												
AVAILABLE	NOT APPLICABLE	34566-5323	G	0	G	BLUE	<table border="1"> <tr><td>80</td><td>78</td><td>77</td><td>75</td><td>74</td><td>73</td><td>72</td><td>70</td><td>69</td><td>67</td><td>65</td><td>64</td><td>63</td><td>62</td><td></td><td></td></tr> <tr><td>60</td><td>58</td><td>57</td><td>55</td><td>54</td><td>52</td><td>51</td><td>50</td><td>49</td><td>47</td><td>45</td><td>44</td><td>43</td><td>42</td><td></td><td></td></tr> <tr><td>40</td><td>38</td><td>37</td><td></td><td></td><td></td><td>33</td><td>32</td><td>31</td><td></td><td>27</td><td>26</td><td>25</td><td>24</td><td></td><td></td></tr> <tr><td>20</td><td>18</td><td>17</td><td></td><td></td><td></td><td></td><td>10</td><td>9</td><td>8</td><td></td><td>6</td><td>5</td><td>4</td><td>3</td><td>2</td><td>1</td></tr> </table>	80	78	77	75	74	73	72	70	69	67	65	64	63	62			60	58	57	55	54	52	51	50	49	47	45	44	43	42			40	38	37				33	32	31		27	26	25	24			20	18	17					10	9	8		6	5	4	3	2	1			
80	78	77	75	74	73	72	70	69	67	65	64	63	62																																																														
60	58	57	55	54	52	51	50	49	47	45	44	43	42																																																														
40	38	37				33	32	31		27	26	25	24																																																														
20	18	17					10	9	8		6	5	4	3	2	1																																																											
AVAILABLE	NOT APPLICABLE	34566-5333	G	0	A	BLACK	<table border="1"> <tr><td>72</td><td>71</td><td>70</td><td>68</td><td>67</td><td>66</td><td>65</td><td>64</td><td>63</td><td>62</td><td>60</td><td>59</td><td></td><td>56</td><td></td><td>53</td></tr> <tr><td>51</td><td></td><td>49</td><td>48</td><td>47</td><td>46</td><td>45</td><td>44</td><td>43</td><td></td><td>41</td><td>40</td><td></td><td></td><td></td><td></td></tr> <tr><td></td><td>73</td><td></td><td></td><td></td><td>30</td><td>29</td><td>28</td><td></td><td>26</td><td>25</td><td>24</td><td></td><td></td><td>20</td><td></td><td>17</td></tr> <tr><td></td><td></td><td></td><td></td><td></td><td></td><td></td><td>12</td><td>11</td><td></td><td></td><td></td><td></td><td></td><td></td><td></td><td></td></tr> </table>	72	71	70	68	67	66	65	64	63	62	60	59		56		53	51		49	48	47	46	45	44	43		41	40						73				30	29	28		26	25	24			20		17								12	11										
72	71	70	68	67	66	65	64	63	62	60	59		56		53																																																												
51		49	48	47	46	45	44	43		41	40																																																																
	73				30	29	28		26	25	24			20		17																																																											
							12	11																																																																			
AVAILABLE	NOT APPLICABLE	34566-5343	G	0	B	ST.GRAY	<table border="1"> <tr><td></td><td></td><td></td><td>68</td><td>67</td><td></td><td>64</td><td></td><td></td><td></td><td>59</td><td>58</td><td></td><td></td><td>54</td><td></td></tr> <tr><td></td><td></td><td></td><td></td><td>46</td><td>45</td><td></td><td></td><td></td><td></td><td>39</td><td>38</td><td></td><td></td><td></td><td></td></tr> <tr><td></td><td>73</td><td></td><td>32</td><td>30</td><td>29</td><td>28</td><td>27</td><td></td><td></td><td>23</td><td>22</td><td></td><td></td><td></td><td>17</td></tr> <tr><td></td><td></td><td></td><td></td><td></td><td></td><td></td><td>12</td><td>10</td><td>8</td><td>6</td><td></td><td></td><td></td><td></td><td></td><td>1</td></tr> </table>				68	67		64				59	58			54						46	45					39	38						73		32	30	29	28	27			23	22				17								12	10	8	6						1			
			68	67		64				59	58			54																																																													
				46	45					39	38																																																																
	73		32	30	29	28	27			23	22				17																																																												
							12	10	8	6						1																																																											
AVAILABLE	NOT APPLICABLE	34566-5353	G	9	B	ST.GRAY	<table border="1"> <tr><td></td><td></td><td></td><td>68</td><td>67</td><td></td><td>64</td><td>63</td><td></td><td></td><td>59</td><td>58</td><td></td><td>55</td><td>54</td></tr> <tr><td></td><td></td><td></td><td></td><td>46</td><td>45</td><td>44</td><td>43</td><td></td><td></td><td>39</td><td>38</td><td></td><td>35</td><td>34</td></tr> <tr><td></td><td>73</td><td></td><td>32</td><td>30</td><td>29</td><td>28</td><td>27</td><td></td><td></td><td>23</td><td>22</td><td></td><td>19</td><td>17</td></tr> <tr><td></td><td></td><td></td><td>15</td><td>13</td><td>12</td><td>10</td><td></td><td></td><td></td><td>6</td><td></td><td></td><td></td><td>1</td></tr> </table>				68	67		64	63			59	58		55	54					46	45	44	43			39	38		35	34		73		32	30	29	28	27			23	22		19	17				15	13	12	10				6				1								
			68	67		64	63			59	58		55	54																																																													
				46	45	44	43			39	38		35	34																																																													
	73		32	30	29	28	27			23	22		19	17																																																													
			15	13	12	10				6				1																																																													
AVAILABLE	NOT APPLICABLE	34566-5363	G	0	C	BLUE	<table border="1"> <tr><td>72</td><td>70</td><td>68</td><td>66</td><td></td><td>63</td><td>62</td><td></td><td>59</td><td>57</td><td></td><td></td><td></td><td>53</td></tr> <tr><td>52</td><td>51</td><td></td><td>48</td><td>47</td><td>46</td><td>44</td><td>42</td><td>40</td><td>39</td><td>38</td><td></td><td></td><td>34</td><td>33</td></tr> <tr><td></td><td>73</td><td></td><td>32</td><td>30</td><td></td><td></td><td>26</td><td>25</td><td></td><td>22</td><td>21</td><td></td><td></td><td></td></tr> <tr><td></td><td></td><td></td><td>15</td><td>14</td><td></td><td></td><td>10</td><td>9</td><td></td><td>6</td><td>5</td><td>4</td><td></td><td></td></tr> </table>	72	70	68	66		63	62		59	57				53	52	51		48	47	46	44	42	40	39	38			34	33		73		32	30			26	25		22	21							15	14			10	9		6	5	4											
72	70	68	66		63	62		59	57				53																																																														
52	51		48	47	46	44	42	40	39	38			34	33																																																													
	73		32	30			26	25		22	21																																																																
			15	14			10	9		6	5	4																																																															
AVAILABLE	NOT APPLICABLE	34566-5373	G	0	C	BLUE	<table border="1"> <tr><td>72</td><td>70</td><td>68</td><td>66</td><td></td><td>63</td><td>62</td><td></td><td>59</td><td>57</td><td></td><td></td><td></td><td>53</td></tr> <tr><td>52</td><td>51</td><td></td><td>48</td><td>47</td><td>46</td><td>44</td><td>42</td><td>40</td><td>39</td><td></td><td></td><td></td><td>34</td><td>33</td></tr> <tr><td></td><td>73</td><td></td><td>32</td><td>30</td><td></td><td></td><td>26</td><td>25</td><td></td><td>22</td><td>21</td><td></td><td></td><td></td></tr> <tr><td></td><td></td><td></td><td>15</td><td>14</td><td></td><td></td><td>10</td><td>9</td><td></td><td>6</td><td></td><td></td><td></td><td></td></tr> </table>	72	70	68	66		63	62		59	57				53	52	51		48	47	46	44	42	40	39				34	33		73		32	30			26	25		22	21							15	14			10	9		6													
72	70	68	66		63	62		59	57				53																																																														
52	51		48	47	46	44	42	40	39				34	33																																																													
	73		32	30			26	25		22	21																																																																
			15	14			10	9		6																																																																	

ENTER DESCRIPTION DEC NO: UAU2016-0232 DRAWN BY: GJ34 CHKD: APPR: VKOSHY 2015/08/14 2015/08/14	QUALITY SYMBOLS	GENERAL TOLERANCES (UNLESS SPECIFIED)	DIMENSION STYLE	SCALE	DESIGN UNITS	THIRD ANGLE PROJECTION
	▽=0	mm INCH	MM ONLY	1:1	METRIC	
	▽=0	4 PLACES # --- # ---	DRAWN BY DATE	TITLE		
	▽=0	3 PLACES # --- # ---	SKRA JENDRANA 2011/02/14	MX123 66/73/80CKT HRNS CONN ASSY		
▽=0	2 PLACES # --- # ---	CHECKED BY DATE	APPROVED BY DATE			
▽=0	1 PLACE # --- # ---	MVANS LAMBROU 2011/02/14				
▽=0	0 PLACE # --- # ---					
	ANGULAR ± --- °	MATERIAL NO.	DOCUMENT NO.			SHEET NO.
	DRAFT WHERE APPLICABLE MUST REMAIN WITHIN DIMENSIONS	SEE BOM	SD-34566-001			60 OF 85
		SIZE D	THIS DRAWING CONTAINS INFORMATION THAT IS PROPRIETARY TO MOLEX INCORPORATED AND SHOULD NOT BE USED WITHOUT WRITTEN PERMISSION			

STATUS	GM PART #	MATERIAL #	PART/MATERIAL REVISION	WIRE DRESS OPTION	KEY OPTION P	COLOR (TPA) P	NUMBERS INDICATE CAVITIES OPEN FOR CIRCUITS P																																																																
AVAILABLE	NOT APPLICABLE	34566-5383	G	0	C	BLUE	<table border="1"> <tr><td>72</td><td>70</td><td>68</td><td>66</td><td>63</td><td>62</td><td>59</td><td>57</td><td>53</td></tr> <tr><td>52</td><td>51</td><td>48</td><td>47</td><td>46</td><td>44</td><td>42</td><td>40</td><td>39</td><td>37</td><td>36</td><td>34</td><td>33</td></tr> <tr><td colspan="2">73</td><td>32</td><td>30</td><td>26</td><td>25</td><td>24</td><td>22</td><td>21</td><td colspan="4"></td></tr> <tr><td colspan="2"></td><td>15</td><td>14</td><td colspan="2"></td><td>10</td><td>9</td><td>8</td><td>6</td><td>5</td><td>4</td><td>2</td></tr> </table>	72	70	68	66	63	62	59	57	53	52	51	48	47	46	44	42	40	39	37	36	34	33	73		32	30	26	25	24	22	21							15	14			10	9	8	6	5	4	2																
72	70	68	66	63	62	59	57	53																																																															
52	51	48	47	46	44	42	40	39	37	36	34	33																																																											
73		32	30	26	25	24	22	21																																																															
		15	14			10	9	8	6	5	4	2																																																											
AVAILABLE	NOT APPLICABLE	34566-5393	G	0	A	BLACK	<table border="1"> <tr><td></td><td>70</td><td>69</td><td></td><td></td><td>63</td><td></td><td></td><td></td><td></td><td>56</td><td>55</td><td>54</td><td>53</td></tr> <tr><td>52</td><td>51</td><td>49</td><td></td><td></td><td>44</td><td>43</td><td>42</td><td>41</td><td></td><td></td><td>36</td><td>34</td><td></td></tr> <tr><td colspan="2">73</td><td>32</td><td></td><td></td><td>28</td><td>26</td><td></td><td></td><td>23</td><td>21</td><td>19</td><td>18</td><td></td></tr> <tr><td colspan="2"></td><td>16</td><td></td><td></td><td>12</td><td>10</td><td></td><td>8</td><td></td><td>5</td><td>3</td><td></td><td></td></tr> </table>		70	69			63					56	55	54	53	52	51	49			44	43	42	41			36	34		73		32			28	26			23	21	19	18				16			12	10		8		5	3										
	70	69			63					56	55	54	53																																																										
52	51	49			44	43	42	41			36	34																																																											
73		32			28	26			23	21	19	18																																																											
		16			12	10		8		5	3																																																												
AVAILABLE	NOT APPLICABLE	34566-5413	G	0	A	BLACK	<table border="1"> <tr><td></td><td>70</td><td>69</td><td></td><td></td><td>63</td><td></td><td></td><td></td><td></td><td>56</td><td>55</td><td>54</td><td>53</td></tr> <tr><td>52</td><td>51</td><td>49</td><td></td><td></td><td>44</td><td>43</td><td>42</td><td>41</td><td></td><td></td><td>36</td><td>34</td><td></td></tr> <tr><td colspan="2">73</td><td>32</td><td></td><td></td><td>28</td><td>26</td><td></td><td></td><td>23</td><td>21</td><td>19</td><td>18</td><td></td></tr> <tr><td colspan="2"></td><td>16</td><td>15</td><td></td><td>12</td><td>10</td><td></td><td>8</td><td></td><td>5</td><td>3</td><td></td><td></td></tr> </table>		70	69			63					56	55	54	53	52	51	49			44	43	42	41			36	34		73		32			28	26			23	21	19	18				16	15		12	10		8		5	3										
	70	69			63					56	55	54	53																																																										
52	51	49			44	43	42	41			36	34																																																											
73		32			28	26			23	21	19	18																																																											
		16	15		12	10		8		5	3																																																												
AVAILABLE	NOT APPLICABLE	34566-5423	G	0	A	BLACK	<table border="1"> <tr><td></td><td>70</td><td>69</td><td></td><td></td><td>63</td><td></td><td></td><td></td><td></td><td>58</td><td>56</td><td>55</td><td>54</td><td>53</td></tr> <tr><td>52</td><td>51</td><td>49</td><td></td><td></td><td>44</td><td>43</td><td>42</td><td>41</td><td></td><td></td><td>36</td><td>34</td><td></td><td></td></tr> <tr><td colspan="2">73</td><td>32</td><td></td><td></td><td>28</td><td>26</td><td></td><td></td><td></td><td></td><td></td><td>19</td><td>18</td><td></td></tr> <tr><td colspan="2"></td><td>16</td><td></td><td></td><td>12</td><td>10</td><td></td><td></td><td></td><td></td><td></td><td>3</td><td></td><td></td></tr> </table>		70	69			63					58	56	55	54	53	52	51	49			44	43	42	41			36	34			73		32			28	26						19	18				16			12	10						3						
	70	69			63					58	56	55	54	53																																																									
52	51	49			44	43	42	41			36	34																																																											
73		32			28	26						19	18																																																										
		16			12	10						3																																																											
AVAILABLE	NOT APPLICABLE	34566-5433	G	9	B	ST.GRAY	<table border="1"> <tr><td></td><td></td><td>68</td><td>67</td><td></td><td>64</td><td></td><td></td><td></td><td>59</td><td>58</td><td></td><td></td><td>54</td><td></td></tr> <tr><td></td><td></td><td></td><td>46</td><td>45</td><td></td><td></td><td></td><td></td><td>39</td><td>38</td><td></td><td></td><td></td><td></td></tr> <tr><td colspan="2">73</td><td>32</td><td>30</td><td>29</td><td>28</td><td>27</td><td></td><td></td><td>23</td><td>22</td><td></td><td></td><td>17</td><td></td></tr> <tr><td colspan="2"></td><td></td><td></td><td></td><td></td><td></td><td>10</td><td></td><td>6</td><td></td><td></td><td></td><td></td><td>1</td></tr> </table>			68	67		64				59	58			54					46	45					39	38					73		32	30	29	28	27			23	22			17									10		6					1				
		68	67		64				59	58			54																																																										
			46	45					39	38																																																													
73		32	30	29	28	27			23	22			17																																																										
							10		6					1																																																									
AVAILABLE	NOT APPLICABLE	34566-5443	G	9	B	ST.GRAY	<table border="1"> <tr><td></td><td></td><td>68</td><td>67</td><td></td><td>64</td><td></td><td></td><td></td><td>59</td><td>58</td><td></td><td></td><td>54</td><td></td></tr> <tr><td></td><td></td><td></td><td>46</td><td>45</td><td></td><td></td><td></td><td></td><td>39</td><td>38</td><td></td><td></td><td></td><td></td></tr> <tr><td colspan="2">73</td><td>32</td><td>30</td><td>29</td><td>28</td><td>27</td><td></td><td></td><td>23</td><td>22</td><td></td><td></td><td>17</td><td></td></tr> <tr><td colspan="2"></td><td></td><td>15</td><td>13</td><td></td><td></td><td>10</td><td></td><td>6</td><td></td><td></td><td></td><td></td><td>1</td></tr> </table>			68	67		64				59	58			54					46	45					39	38					73		32	30	29	28	27			23	22			17					15	13			10		6					1				
		68	67		64				59	58			54																																																										
			46	45					39	38																																																													
73		32	30	29	28	27			23	22			17																																																										
			15	13			10		6					1																																																									
AVAILABLE	NOT APPLICABLE	34566-5453	G	0	B	ST.GRAY	<table border="1"> <tr><td></td><td></td><td>68</td><td>67</td><td></td><td>64</td><td></td><td></td><td></td><td>59</td><td>58</td><td></td><td></td><td>54</td><td></td></tr> <tr><td></td><td></td><td></td><td>46</td><td>45</td><td></td><td></td><td></td><td></td><td>39</td><td>38</td><td></td><td></td><td></td><td></td></tr> <tr><td colspan="2">73</td><td>32</td><td>30</td><td>29</td><td>28</td><td>27</td><td></td><td></td><td>23</td><td>22</td><td></td><td></td><td>17</td><td></td></tr> <tr><td colspan="2"></td><td></td><td>15</td><td>13</td><td></td><td></td><td>10</td><td></td><td>6</td><td></td><td></td><td></td><td></td><td>1</td></tr> </table>			68	67		64				59	58			54					46	45					39	38					73		32	30	29	28	27			23	22			17					15	13			10		6					1				
		68	67		64				59	58			54																																																										
			46	45					39	38																																																													
73		32	30	29	28	27			23	22			17																																																										
			15	13			10		6					1																																																									
AVAILABLE	NOT APPLICABLE	34566-5463	G	0	A	BLACK	<table border="1"> <tr><td>72</td><td>70</td><td></td><td></td><td></td><td>63</td><td></td><td></td><td></td><td></td><td></td><td></td><td></td><td></td><td></td></tr> <tr><td>52</td><td></td><td>49</td><td></td><td></td><td></td><td></td><td></td><td>41</td><td></td><td></td><td></td><td></td><td></td><td></td></tr> <tr><td colspan="2">73</td><td></td><td>31</td><td>30</td><td>28</td><td>27</td><td>26</td><td></td><td>23</td><td></td><td>20</td><td>19</td><td></td><td></td></tr> <tr><td colspan="2"></td><td>16</td><td>15</td><td>14</td><td>12</td><td>10</td><td></td><td></td><td>6</td><td></td><td></td><td></td><td></td><td></td></tr> </table>	72	70				63										52		49						41							73			31	30	28	27	26		23		20	19					16	15	14	12	10			6									
72	70				63																																																																		
52		49						41																																																															
73			31	30	28	27	26		23		20	19																																																											
		16	15	14	12	10			6																																																														
AVAILABLE	NOT APPLICABLE	34566-5473	G	0	A	BLACK	<table border="1"> <tr><td>72</td><td>71</td><td>70</td><td>68</td><td>67</td><td>66</td><td>65</td><td>64</td><td>63</td><td>62</td><td>60</td><td>59</td><td></td><td>56</td><td></td><td>53</td></tr> <tr><td>52</td><td>51</td><td></td><td>48</td><td>47</td><td>46</td><td>45</td><td>44</td><td>43</td><td>42</td><td>41</td><td>40</td><td></td><td></td><td></td><td></td></tr> <tr><td colspan="2">73</td><td></td><td>31</td><td>30</td><td>29</td><td>28</td><td>27</td><td>26</td><td>25</td><td>24</td><td>23</td><td></td><td>20</td><td>19</td><td>17</td></tr> <tr><td colspan="2"></td><td>16</td><td>15</td><td>14</td><td>12</td><td>11</td><td>10</td><td></td><td></td><td></td><td>6</td><td></td><td></td><td></td><td></td></tr> </table>	72	71	70	68	67	66	65	64	63	62	60	59		56		53	52	51		48	47	46	45	44	43	42	41	40					73			31	30	29	28	27	26	25	24	23		20	19	17			16	15	14	12	11	10				6				
72	71	70	68	67	66	65	64	63	62	60	59		56		53																																																								
52	51		48	47	46	45	44	43	42	41	40																																																												
73			31	30	29	28	27	26	25	24	23		20	19	17																																																								
		16	15	14	12	11	10				6																																																												

ENTER DESCRIPTION DEC NO: JAU2016-0232 DRAWN BY: G34 CHKD: G34 APPR: WOSHY 2015/08/14 2015/08/14 DESCRIPTION	QUALITY SYMBOLS	GENERAL TOLERANCES (UNLESS SPECIFIED)	DIMENSION STYLE	SCALE	DESIGN UNITS	THIRD ANGLE PROJECTION	
	▽=0	mm INCH	MM ONLY	1:1	METRIC		
	▽=0	4 PLACES ± --- ± ---	DRAWN BY DATE	TITLE			
	▽=0	3 PLACES ± --- ± ---	SKRA JENDRANA 2011/02/14	MX123 66/73/80CKT HRNS CONN ASSY			
▽=0	2 PLACES ± --- ± ---	2 PLACES ± --- ± ---	CHECKED BY DATE	MATERIAL NO. DOCUMENT NO.			
▽=0	1 PLACE ± --- ± ---	1 PLACE ± --- ± ---	APPROVED BY DATE	SD-34566-001			
▽=0	0 PLACE ± --- ± ---	0 PLACE ± --- ± ---		SHEET NO. 61 OF 85			
	ANGULAR ± ---°	DRAFT WHERE APPLICABLE MUST REMAIN WITHIN DIMENSIONS	SEE BOM TABLE	THIS DRAWING CONTAINS INFORMATION THAT IS PROPRIETARY TO MOLEX INCORPORATED AND SHOULD NOT BE USED WITHOUT WRITTEN PERMISSION			

STATUS	GM PART #	MATERIAL #	PART/MATERIAL REVISION	WIRE DRESS OPTION	KEY OPTION P	COLOR (TPA) P	NUMBERS INDICATE CAVITIES OPEN FOR CIRCUITS P																																																																		
AVAILABLE	NOT APPLICABLE	34566-5483	G	0	B	ST.GRAY	<table border="1"> <tr><td>72</td><td>70</td><td>68</td><td>66</td><td>64</td><td>63</td><td></td><td>60</td><td>59</td><td></td><td>55</td><td>54</td><td>53</td></tr> <tr><td>52</td><td>50</td><td>48</td><td>46</td><td></td><td></td><td></td><td>40</td><td>39</td><td></td><td>35</td><td>34</td><td>33</td></tr> <tr><td></td><td>73</td><td>32</td><td>31</td><td>30</td><td>29</td><td>28</td><td>27</td><td>26</td><td>25</td><td>24</td><td></td><td>20</td><td>17</td></tr> <tr><td></td><td></td><td>16</td><td></td><td></td><td></td><td></td><td></td><td>10</td><td>8</td><td></td><td>5</td><td>4</td><td>2</td><td>1</td></tr> </table>	72	70	68	66	64	63		60	59		55	54	53	52	50	48	46				40	39		35	34	33		73	32	31	30	29	28	27	26	25	24		20	17			16						10	8		5	4	2	1											
72	70	68	66	64	63		60	59		55	54	53																																																													
52	50	48	46				40	39		35	34	33																																																													
	73	32	31	30	29	28	27	26	25	24		20	17																																																												
		16						10	8		5	4	2	1																																																											
AVAILABLE	NOT APPLICABLE	34566-5493	G	0	A	BLACK	<table border="1"> <tr><td>72</td><td>70</td><td>69</td><td></td><td></td><td></td><td>63</td><td></td><td>60</td><td>59</td><td>58</td><td>57</td><td>56</td><td>55</td><td>54</td><td>53</td></tr> <tr><td>52</td><td>51</td><td>49</td><td></td><td></td><td></td><td>44</td><td>43</td><td>42</td><td>41</td><td>40</td><td></td><td>37</td><td>36</td><td></td><td>34</td></tr> <tr><td></td><td>73</td><td></td><td>32</td><td></td><td></td><td>28</td><td></td><td>26</td><td></td><td></td><td></td><td></td><td>19</td><td>18</td><td>17</td></tr> <tr><td></td><td></td><td></td><td>16</td><td>15</td><td></td><td>12</td><td></td><td>10</td><td></td><td></td><td></td><td></td><td>3</td><td>2</td><td>1</td></tr> </table>	72	70	69				63		60	59	58	57	56	55	54	53	52	51	49				44	43	42	41	40		37	36		34		73		32			28		26					19	18	17				16	15		12		10					3	2	1		
72	70	69				63		60	59	58	57	56	55	54	53																																																										
52	51	49				44	43	42	41	40		37	36		34																																																										
	73		32			28		26					19	18	17																																																										
			16	15		12		10					3	2	1																																																										
AVAILABLE	NOT APPLICABLE	34566-5513	G	9	B	ST.GRAY	<table border="1"> <tr><td></td><td></td><td></td><td>68</td><td>67</td><td></td><td>64</td><td>63</td><td></td><td></td><td></td><td></td><td>58</td><td></td><td>55</td><td></td></tr> <tr><td></td><td></td><td></td><td></td><td>46</td><td>45</td><td></td><td>43</td><td></td><td></td><td></td><td></td><td>38</td><td></td><td>35</td><td></td></tr> <tr><td></td><td>73</td><td></td><td>32</td><td></td><td>30</td><td>29</td><td>28</td><td>27</td><td></td><td></td><td></td><td>22</td><td></td><td>19</td><td>17</td></tr> <tr><td></td><td></td><td></td><td></td><td></td><td></td><td></td><td></td><td>10</td><td></td><td></td><td></td><td></td><td></td><td></td><td>1</td></tr> </table>				68	67		64	63					58		55						46	45		43					38		35			73		32		30	29	28	27				22		19	17									10							1		
			68	67		64	63					58		55																																																											
				46	45		43					38		35																																																											
	73		32		30	29	28	27				22		19	17																																																										
								10							1																																																										
AVAILABLE	NOT APPLICABLE	34566-5523	G	9	A	BLACK	<table border="1"> <tr><td>72</td><td></td><td>69</td><td>67</td><td>66</td><td>65</td><td>63</td><td></td><td>60</td><td></td><td>57</td><td>56</td><td></td><td>53</td></tr> <tr><td></td><td></td><td>49</td><td>47</td><td></td><td>44</td><td>43</td><td>42</td><td>40</td><td></td><td>37</td><td>36</td><td>35</td><td>33</td></tr> <tr><td></td><td>73</td><td></td><td>31</td><td>30</td><td>29</td><td>28</td><td>27</td><td>26</td><td>24</td><td>21</td><td>20</td><td></td><td>17</td></tr> <tr><td></td><td></td><td></td><td>16</td><td>15</td><td>14</td><td>13</td><td>11</td><td>10</td><td></td><td></td><td>5</td><td>4</td><td>3</td><td>2</td><td>1</td></tr> </table>	72		69	67	66	65	63		60		57	56		53			49	47		44	43	42	40		37	36	35	33		73		31	30	29	28	27	26	24	21	20		17				16	15	14	13	11	10			5	4	3	2	1								
72		69	67	66	65	63		60		57	56		53																																																												
		49	47		44	43	42	40		37	36	35	33																																																												
	73		31	30	29	28	27	26	24	21	20		17																																																												
			16	15	14	13	11	10			5	4	3	2	1																																																										
AVAILABLE	NOT APPLICABLE	34566-5533	G	9	B	ST.GRAY	<table border="1"> <tr><td></td><td></td><td></td><td>68</td><td>67</td><td></td><td>64</td><td></td><td></td><td></td><td>59</td><td>58</td><td></td><td>54</td></tr> <tr><td></td><td></td><td></td><td></td><td>46</td><td>45</td><td></td><td></td><td></td><td></td><td>39</td><td>38</td><td></td><td></td></tr> <tr><td></td><td>73</td><td></td><td>32</td><td></td><td>30</td><td>29</td><td>28</td><td>27</td><td></td><td>23</td><td>22</td><td></td><td>17</td></tr> <tr><td></td><td></td><td></td><td></td><td></td><td></td><td></td><td></td><td>10</td><td>9</td><td>8</td><td>6</td><td></td><td></td><td></td><td>1</td></tr> </table>				68	67		64				59	58		54					46	45					39	38				73		32		30	29	28	27		23	22		17									10	9	8	6				1								
			68	67		64				59	58		54																																																												
				46	45					39	38																																																														
	73		32		30	29	28	27		23	22		17																																																												
								10	9	8	6				1																																																										
AVAILABLE	NOT APPLICABLE	34566-5543	G	9	A	BLACK	<table border="1"> <tr><td></td><td></td><td></td><td>68</td><td>67</td><td></td><td>64</td><td></td><td></td><td></td><td>59</td><td>58</td><td></td><td>54</td></tr> <tr><td></td><td></td><td></td><td></td><td>46</td><td>45</td><td></td><td></td><td></td><td></td><td>39</td><td>38</td><td></td><td></td></tr> <tr><td></td><td>73</td><td></td><td>32</td><td></td><td>30</td><td>29</td><td>28</td><td>27</td><td></td><td>23</td><td>22</td><td></td><td>17</td></tr> <tr><td></td><td></td><td></td><td></td><td></td><td></td><td></td><td>12</td><td>10</td><td>8</td><td>6</td><td></td><td></td><td></td><td></td><td>1</td></tr> </table>				68	67		64				59	58		54					46	45					39	38				73		32		30	29	28	27		23	22		17								12	10	8	6					1								
			68	67		64				59	58		54																																																												
				46	45					39	38																																																														
	73		32		30	29	28	27		23	22		17																																																												
							12	10	8	6					1																																																										
AVAILABLE	NOT APPLICABLE	34566-5553	G	9	B	ST.GRAY	<table border="1"> <tr><td></td><td></td><td></td><td>68</td><td>67</td><td></td><td>64</td><td></td><td></td><td></td><td>59</td><td>58</td><td></td><td>54</td></tr> <tr><td></td><td></td><td></td><td></td><td>46</td><td>45</td><td></td><td></td><td></td><td></td><td>39</td><td>38</td><td></td><td></td></tr> <tr><td></td><td>73</td><td></td><td>32</td><td></td><td>30</td><td>29</td><td>28</td><td>27</td><td></td><td>23</td><td>22</td><td></td><td>17</td></tr> <tr><td></td><td></td><td></td><td></td><td></td><td></td><td></td><td>12</td><td>10</td><td>8</td><td>6</td><td></td><td></td><td></td><td></td><td>1</td></tr> </table>				68	67		64				59	58		54					46	45					39	38				73		32		30	29	28	27		23	22		17								12	10	8	6					1								
			68	67		64				59	58		54																																																												
				46	45					39	38																																																														
	73		32		30	29	28	27		23	22		17																																																												
							12	10	8	6					1																																																										
AVAILABLE	NOT APPLICABLE	34566-5563	G	0	A	BLACK	<table border="1"> <tr><td>72</td><td>71</td><td>70</td><td>69</td><td></td><td></td><td>64</td><td>63</td><td></td><td>60</td><td>59</td><td>58</td><td>57</td><td>56</td><td>55</td><td>54</td><td>53</td></tr> <tr><td>52</td><td>51</td><td>49</td><td>48</td><td>47</td><td></td><td>45</td><td>44</td><td>43</td><td>42</td><td>41</td><td></td><td>37</td><td>36</td><td></td><td>34</td><td>33</td></tr> <tr><td></td><td>73</td><td></td><td>32</td><td></td><td>30</td><td></td><td>28</td><td></td><td>26</td><td></td><td></td><td></td><td>19</td><td>18</td><td>17</td></tr> <tr><td></td><td></td><td></td><td>16</td><td>15</td><td></td><td></td><td>12</td><td></td><td>10</td><td></td><td></td><td></td><td>3</td><td>2</td><td>1</td></tr> </table>	72	71	70	69			64	63		60	59	58	57	56	55	54	53	52	51	49	48	47		45	44	43	42	41		37	36		34	33		73		32		30		28		26				19	18	17				16	15			12		10				3	2	1
72	71	70	69			64	63		60	59	58	57	56	55	54	53																																																									
52	51	49	48	47		45	44	43	42	41		37	36		34	33																																																									
	73		32		30		28		26				19	18	17																																																										
			16	15			12		10				3	2	1																																																										
AVAILABLE	NOT APPLICABLE	34566-5573	G	0	C	BLUE	<table border="1"> <tr><td>72</td><td>70</td><td>68</td><td>66</td><td></td><td>63</td><td>62</td><td></td><td>59</td><td>58</td><td>57</td><td>56</td><td>55</td><td>53</td></tr> <tr><td>52</td><td>51</td><td>49</td><td>48</td><td>47</td><td>46</td><td>44</td><td>42</td><td>40</td><td>39</td><td>38</td><td>37</td><td>36</td><td>34</td><td>33</td></tr> <tr><td></td><td>73</td><td></td><td>32</td><td></td><td>30</td><td></td><td>26</td><td>25</td><td>24</td><td>23</td><td>22</td><td>21</td><td>20</td><td>19</td><td>18</td><td>17</td></tr> <tr><td></td><td></td><td></td><td></td><td>15</td><td>14</td><td>13</td><td></td><td>10</td><td>9</td><td>8</td><td>7</td><td>6</td><td>5</td><td>4</td><td>2</td><td>1</td></tr> </table>	72	70	68	66		63	62		59	58	57	56	55	53	52	51	49	48	47	46	44	42	40	39	38	37	36	34	33		73		32		30		26	25	24	23	22	21	20	19	18	17					15	14	13		10	9	8	7	6	5	4	2	1			
72	70	68	66		63	62		59	58	57	56	55	53																																																												
52	51	49	48	47	46	44	42	40	39	38	37	36	34	33																																																											
	73		32		30		26	25	24	23	22	21	20	19	18	17																																																									
				15	14	13		10	9	8	7	6	5	4	2	1																																																									

ENTER DESCRIPTION DEC NO. UAU2016-0232 DRAWN BY CHKD: G34 APPR:VKOSHY 2015/08/14 DESCRIPTION	QUALITY SYMBOLS	GENERAL TOLERANCES (UNLESS SPECIFIED)	DIMENSION STYLE	SCALE	DESIGN UNITS	THIRD ANGLE PROJECTION
	▽=0	mm INCH	MM ONLY	1:1	METRIC	
	▽=0	4 PLACES ±--- ±---	DRAWN BY SKRA JENDRANA	DATE 2011/02/14	TITLE	MX123
	▽=0	3 PLACES ±--- ±---	CHECKED BY	DATE		66/73/80CKT
	2 PLACES ±--- ±---	1 PLACE ±--- ±---	APPROVED BY	DATE		HRNS CONN ASSY
	0 PLACE ±--- ±---	ANGULAR ±--- ±---	MATERIAL NO.	DOCUMENT NO.		molex
	DRAFT WHERE APPLICABLE MUST REMAIN WITHIN DIMENSIONS	SEE BOM TABLE				SD-34566-001
						SHEET NO. 62 OF 85

STATUS	GM PART #	MATERIAL #	PART/ MATERIAL REVISION	WIRE DRESS OPTION	KEY OPTION FP	COLOR (TPA) FP	NUMBERS INDICATE CAVITIES OPEN FOR CIRCUITS FP																																																						
AVAILABLE	NOT APPLICABLE	34566-5583	G	0	B	ST.GRAY	72	70	68	66	64	63	60	59	55	54	53	52	50	48	46	44	42	40	39	35	34	33	73	32	31	30	29	28	27	26	25	24	23	20	17	16	15	14	13	12	11	10	9	8	7	6	5	4	2	1					
AVAILABLE	NOT APPLICABLE	34566-5593	G	0	C	BLUE	72	70	68	66	64	63	62	59	57	55	53	52	51	48	47	46	44	42	40	39	37	36	34	33	73	32	30	26	25	23	22	21	20	17	15	14	10	9	7	6	5	4	2	1											
AVAILABLE	NOT APPLICABLE	34566-5613	G	0	C	BLUE	72	70	68	66	64	63	62	59	58	57	53	52	51	48	47	44	42	40	39	37	36	34	33	73	32	30	27	26	25	24	23	22	21	20	17	15	14	13	8	7	6	5	4	2	1										
AVAILABLE	NOT APPLICABLE	34566-5623	G	0	C	BLUE	72	70	68	66	64	63	62	59	57	53	52	51	48	47	44	42	40	39	37	36	34	33	73	32	30	27	26	25	24	23	22	21	20	17	15	14	13	8	7	6	5	4	2	1											
AVAILABLE	NOT APPLICABLE	34566-5633	G	0	B	ST.GRAY	72	70	68	66	64	63	62	61	60	57	56	54	53	52	51	48	46	44	43	41	40	37	36	34	33	73	32	30	20	19	18	16	15	14	4	2	1																		
AVAILABLE	NOT APPLICABLE	34566-5643	G	0	B	ST.GRAY	72	70	68	66	64	63	62	61	60	57	56	54	53	52	51	48	46	44	43	41	40	37	36	34	33	73	32	30	20	19	18	16	15	14	4	2	1																		
AVAILABLE	NOT APPLICABLE	34566-5653	G	0	A	BLACK	72	71	70	69	68	66	65	64	63	61	60	57	56	54	53	52	51	50	49	48	46	45	44	43	40	39	38	37	36	34	33	73	32	31	30	29	28	26	25	23	22	21	20	17	15	14	13	12	9	7	6	5	4	2	1
AVAILABLE	NOT APPLICABLE	34566-5663	G	0	C	BLUE	69	67	66	64	62	60	57	55	54	52	51	50	48	46	45	44	42	40	37	35	34	33	73	32	31	28	27	26	25	24	23	22	21	20	17	16	15	14	13	12	11	10	9	8	7	6	5	4	2	1					
AVAILABLE	NOT APPLICABLE	34566-5673	G	0	C	BLUE	69	67	66	64	62	60	57	55	54	52	51	50	49	48	46	45	44	42	40	37	35	34	33	73	32	31	28	27	25	24	23	22	21	20	17	16	15	14	13	12	11	10	9	8	7	6	5	4	2	1					

ENTER DESCRIPTION DEC NO. UAU2016-0232 DRAWN BY G34 CHKD: APPR:VKOSHY 2015/08/14 2015/08/14	QUALITY SYMBOLS	GENERAL TOLERANCES (UNLESS SPECIFIED)	DIMENSION STYLE	SCALE	DESIGN UNITS	THIRD ANGLE PROJECTION
	▽=0	mm INCH	MM ONLY	1:1	METRIC	
	▽=0	4 PLACES ±--- ±---	DRAWN BY DATE	TITLE		
	▽=0	3 PLACES ±--- ±---	SKRA JENDRANA 2011/02/14	MX123		
▽=0	2 PLACES ±--- ±---	CHECKED BY DATE	66/73/80CKT			
▽=0	1 PLACE ±--- ±---	MVANS LAMBROU 2011/02/14	HRNS CONN ASSY			
▽=0	0 PLACE ±--- ±---	APPROVED BY DATE	molex			
	ANGULAR ±--- ±---	MATERIAL NO.	DOCUMENT NO.			
	DRAFT WHERE APPLICABLE MUST REMAIN WITHIN DIMENSIONS	SEE BOM TABLE	SD-34566-001			
		SIZE	SHEET NO. 63 OF 85			
			THIS DRAWING CONTAINS INFORMATION THAT IS PROPRIETARY TO MOLEX INCORPORATED AND SHOULD NOT BE USED WITHOUT WRITTEN PERMISSION			

STATUS	GM PART #	MATERIAL #	PART/MATERIAL REVISION	WIRE DRESS OPTION	KEY OPTION P	COLOR (TPA) P	NUMBERS INDICATE CAVITIES OPEN FOR CIRCUITS P																																																																																							
AVAILABLE	NOT APPLICABLE	34566-5783	G	0	C	BLUE	<table border="1"> <tr><td>72</td><td>70</td><td>68</td><td></td><td></td><td></td><td>63</td><td>62</td><td></td><td></td><td>59</td><td>57</td><td></td><td></td><td>53</td></tr> <tr><td>52</td><td>51</td><td>48</td><td>47</td><td></td><td></td><td>44</td><td>42</td><td></td><td></td><td>40</td><td>39</td><td></td><td></td><td>37</td><td>36</td><td></td><td></td><td>34</td><td>33</td></tr> <tr><td colspan="2">73</td><td>32</td><td>30</td><td></td><td></td><td>27</td><td>26</td><td></td><td></td><td>25</td><td>24</td><td></td><td></td><td>22</td><td>21</td><td></td><td></td><td>20</td><td></td></tr> <tr><td colspan="2"></td><td>15</td><td>14</td><td>13</td><td></td><td></td><td></td><td></td><td></td><td>8</td><td>6</td><td>5</td><td>4</td><td></td><td></td><td></td><td></td><td>2</td><td></td></tr> </table>	72	70	68				63	62			59	57			53	52	51	48	47			44	42			40	39			37	36			34	33	73		32	30			27	26			25	24			22	21			20				15	14	13						8	6	5	4					2													
72	70	68				63	62			59	57			53																																																																																
52	51	48	47			44	42			40	39			37	36			34	33																																																																											
73		32	30			27	26			25	24			22	21			20																																																																												
		15	14	13						8	6	5	4					2																																																																												
(G28) AVAILABLE	NOT APPLICABLE	34566-5793 SAME AS P/N 34566-4013	G	0	B	ST.GRAY	<table border="1"> <tr><td>72</td><td>70</td><td>68</td><td>66</td><td></td><td></td><td></td><td></td><td></td><td></td><td>60</td><td>59</td><td></td><td></td><td>55</td><td>54</td><td>53</td></tr> <tr><td>52</td><td>50</td><td>48</td><td>46</td><td></td><td></td><td></td><td></td><td></td><td></td><td>40</td><td>39</td><td></td><td></td><td>35</td><td>34</td><td>33</td></tr> <tr><td colspan="2">73</td><td>32</td><td>31</td><td>30</td><td>29</td><td>28</td><td>27</td><td>26</td><td>25</td><td>24</td><td></td><td></td><td></td><td></td><td></td><td></td><td></td><td></td><td>17</td></tr> <tr><td colspan="2"></td><td>16</td><td></td><td></td><td></td><td></td><td></td><td></td><td></td><td>10</td><td>8</td><td></td><td></td><td></td><td></td><td></td><td></td><td></td><td>2</td><td>1</td></tr> </table>	72	70	68	66							60	59			55	54	53	52	50	48	46							40	39			35	34	33	73		32	31	30	29	28	27	26	25	24									17			16								10	8								2	1												
72	70	68	66							60	59			55	54	53																																																																														
52	50	48	46							40	39			35	34	33																																																																														
73		32	31	30	29	28	27	26	25	24									17																																																																											
		16								10	8								2	1																																																																										
AVAILABLE	NOT APPLICABLE	34566-5813	G	0	B	ST.GRAY	<table border="1"> <tr><td>72</td><td>70</td><td>68</td><td>66</td><td></td><td></td><td></td><td></td><td></td><td></td><td>60</td><td>59</td><td></td><td></td><td>55</td><td>54</td><td>53</td></tr> <tr><td>52</td><td>50</td><td>48</td><td>46</td><td></td><td></td><td></td><td></td><td></td><td></td><td>40</td><td>39</td><td></td><td></td><td>35</td><td>34</td><td>33</td></tr> <tr><td colspan="2">73</td><td>32</td><td>31</td><td>30</td><td>29</td><td>28</td><td>27</td><td>26</td><td>25</td><td>24</td><td>23</td><td></td><td></td><td>19</td><td>18</td><td>17</td></tr> <tr><td colspan="2"></td><td>16</td><td></td><td></td><td></td><td></td><td></td><td></td><td></td><td>10</td><td>8</td><td>7</td><td></td><td></td><td></td><td></td><td></td><td>2</td><td>1</td></tr> </table>	72	70	68	66							60	59			55	54	53	52	50	48	46							40	39			35	34	33	73		32	31	30	29	28	27	26	25	24	23			19	18	17			16								10	8	7						2	1																
72	70	68	66							60	59			55	54	53																																																																														
52	50	48	46							40	39			35	34	33																																																																														
73		32	31	30	29	28	27	26	25	24	23			19	18	17																																																																														
		16								10	8	7						2	1																																																																											
AVAILABLE	NOT APPLICABLE	34566-5823	G	0	A	BLACK	<table border="1"> <tr><td>72</td><td>70</td><td></td><td></td><td></td><td></td><td>63</td><td></td><td></td><td></td><td></td><td></td><td></td><td></td><td></td><td></td><td></td><td></td><td></td><td></td></tr> <tr><td>52</td><td></td><td>49</td><td></td><td></td><td></td><td>43</td><td></td><td>41</td><td></td><td></td><td></td><td></td><td></td><td></td><td></td><td></td><td></td><td></td><td></td></tr> <tr><td colspan="2">73</td><td></td><td>31</td><td>30</td><td></td><td>28</td><td>27</td><td>26</td><td></td><td></td><td></td><td></td><td></td><td>23</td><td></td><td></td><td></td><td>20</td><td>19</td></tr> <tr><td colspan="2"></td><td></td><td>16</td><td>15</td><td>14</td><td></td><td></td><td></td><td></td><td>10</td><td></td><td></td><td></td><td>6</td><td></td><td></td><td></td><td></td><td></td></tr> </table>	72	70					63														52		49				43		41												73			31	30		28	27	26						23				20	19				16	15	14					10				6												
72	70					63																																																																																								
52		49				43		41																																																																																						
73			31	30		28	27	26						23				20	19																																																																											
			16	15	14					10				6																																																																																
AVAILABLE	NOT APPLICABLE	34566-5833	G	0	A	BLACK	<table border="1"> <tr><td>72</td><td>70</td><td></td><td></td><td></td><td></td><td>63</td><td></td><td></td><td></td><td></td><td></td><td></td><td></td><td></td><td></td><td></td><td></td><td></td><td></td></tr> <tr><td>52</td><td></td><td>49</td><td></td><td></td><td></td><td>43</td><td></td><td>41</td><td></td><td></td><td></td><td></td><td></td><td></td><td></td><td></td><td></td><td></td><td></td></tr> <tr><td colspan="2">73</td><td></td><td>31</td><td>30</td><td></td><td>28</td><td>27</td><td>26</td><td></td><td></td><td></td><td></td><td></td><td>23</td><td></td><td></td><td></td><td>20</td><td>19</td></tr> <tr><td colspan="2"></td><td></td><td>16</td><td>15</td><td>14</td><td></td><td></td><td></td><td></td><td>12</td><td>10</td><td></td><td></td><td>6</td><td></td><td></td><td></td><td></td><td></td></tr> </table>	72	70					63														52		49				43		41												73			31	30		28	27	26						23				20	19				16	15	14					12	10			6												
72	70					63																																																																																								
52		49				43		41																																																																																						
73			31	30		28	27	26						23				20	19																																																																											
			16	15	14					12	10			6																																																																																
AVAILABLE	NOT APPLICABLE	34566-5843	G	0	H	ST.GRAY	<table border="1"> <tr><td>79</td><td></td><td></td><td></td><td></td><td>74</td><td>73</td><td>72</td><td>71</td><td></td><td></td><td>68</td><td>67</td><td></td><td>65</td><td>64</td><td>63</td><td>62</td><td>61</td></tr> <tr><td>59</td><td></td><td>57</td><td></td><td></td><td>54</td><td>52</td><td></td><td></td><td></td><td></td><td></td><td></td><td></td><td></td><td></td><td></td><td></td><td>42</td><td>41</td></tr> <tr><td colspan="2">73</td><td>38</td><td></td><td></td><td>34</td><td>33</td><td></td><td></td><td></td><td>29</td><td></td><td>27</td><td></td><td>25</td><td></td><td></td><td></td><td></td><td></td></tr> <tr><td colspan="2"></td><td>18</td><td></td><td></td><td>15</td><td>14</td><td></td><td></td><td></td><td>11</td><td>10</td><td>9</td><td>8</td><td>7</td><td></td><td></td><td></td><td></td><td></td></tr> </table>	79					74	73	72	71			68	67		65	64	63	62	61	59		57			54	52												42	41	73		38			34	33				29		27		25								18			15	14				11	10	9	8	7													
79					74	73	72	71			68	67		65	64	63	62	61																																																																												
59		57			54	52												42	41																																																																											
73		38			34	33				29		27		25																																																																																
		18			15	14				11	10	9	8	7																																																																																
AVAILABLE	NOT APPLICABLE	34566-5853	G	0	H	ST.GRAY	<table border="1"> <tr><td>79</td><td></td><td></td><td></td><td></td><td>74</td><td>73</td><td>72</td><td>71</td><td></td><td></td><td>68</td><td>67</td><td></td><td>65</td><td>64</td><td>63</td><td>62</td><td>61</td></tr> <tr><td>59</td><td></td><td>57</td><td></td><td></td><td>54</td><td>52</td><td></td><td></td><td></td><td></td><td></td><td></td><td></td><td></td><td></td><td></td><td></td><td>43</td><td>42</td><td>41</td></tr> <tr><td colspan="2">73</td><td>38</td><td></td><td></td><td>33</td><td></td><td></td><td></td><td></td><td>29</td><td></td><td>27</td><td></td><td>25</td><td></td><td></td><td></td><td></td><td></td><td></td></tr> <tr><td colspan="2"></td><td>18</td><td></td><td></td><td>15</td><td>14</td><td></td><td></td><td></td><td>11</td><td>10</td><td>9</td><td>8</td><td>7</td><td></td><td></td><td></td><td></td><td></td><td></td></tr> </table>	79					74	73	72	71			68	67		65	64	63	62	61	59		57			54	52												43	42	41	73		38			33					29		27		25									18			15	14				11	10	9	8	7											
79					74	73	72	71			68	67		65	64	63	62	61																																																																												
59		57			54	52												43	42	41																																																																										
73		38			33					29		27		25																																																																																
		18			15	14				11	10	9	8	7																																																																																
AVAILABLE	NOT APPLICABLE	34566-5863	G	0	C	BLUE	<table border="1"> <tr><td>72</td><td>70</td><td></td><td></td><td></td><td>66</td><td></td><td>63</td><td>62</td><td></td><td></td><td>59</td><td>57</td><td>56</td><td>55</td><td>53</td></tr> <tr><td>52</td><td>51</td><td></td><td></td><td></td><td>46</td><td></td><td>44</td><td>42</td><td></td><td></td><td>40</td><td>39</td><td></td><td></td><td>37</td><td>36</td><td></td><td></td><td>34</td><td>33</td></tr> <tr><td colspan="2">73</td><td></td><td>32</td><td>30</td><td></td><td></td><td></td><td>26</td><td>25</td><td></td><td></td><td>22</td><td>21</td><td></td><td>19</td><td>18</td><td></td><td></td><td></td><td></td></tr> <tr><td colspan="2"></td><td></td><td>15</td><td>14</td><td></td><td></td><td></td><td></td><td></td><td>10</td><td>9</td><td></td><td></td><td>6</td><td></td><td></td><td></td><td></td><td></td><td></td><td></td></tr> </table>	72	70				66		63	62			59	57	56	55	53	52	51				46		44	42			40	39			37	36			34	33	73			32	30				26	25			22	21		19	18								15	14						10	9			6														
72	70				66		63	62			59	57	56	55	53																																																																															
52	51				46		44	42			40	39			37	36			34	33																																																																										
73			32	30				26	25			22	21		19	18																																																																														
			15	14						10	9			6																																																																																
AVAILABLE	NOT APPLICABLE	34566-5873	G	0	B	ST.GRAY	<table border="1"> <tr><td>72</td><td></td><td></td><td></td><td></td><td></td><td></td><td></td><td>62</td><td>61</td><td></td><td></td><td></td><td></td><td></td><td></td><td></td><td></td><td></td><td></td><td></td></tr> <tr><td>52</td><td></td><td></td><td>48</td><td>47</td><td>46</td><td></td><td>44</td><td>43</td><td></td><td>41</td><td>40</td><td></td><td></td><td></td><td></td><td></td><td></td><td></td><td>20</td><td>19</td><td>18</td></tr> <tr><td colspan="2">73</td><td></td><td></td><td></td><td>30</td><td></td><td></td><td></td><td></td><td></td><td></td><td></td><td></td><td></td><td></td><td></td><td></td><td></td><td></td><td>4</td><td></td></tr> <tr><td colspan="2"></td><td></td><td>16</td><td>15</td><td>14</td><td></td><td></td><td></td><td></td><td></td><td></td><td></td><td></td><td></td><td></td><td></td><td></td><td></td><td></td><td></td><td></td></tr> </table>	72								62	61												52			48	47	46		44	43		41	40								20	19	18	73					30															4					16	15	14																
72								62	61																																																																																					
52			48	47	46		44	43		41	40								20	19	18																																																																									
73					30															4																																																																										
			16	15	14																																																																																									

ENTER DESCRIPTION DEC NO. UAU2016-0232 DRAWN BY G34 CHKD: APPR:VKOSHY 2015/08/14 2015/08/14 DESCRIPTION	QUALITY SYMBOLS	GENERAL TOLERANCES (UNLESS SPECIFIED)	DIMENSION STYLE	SCALE	DESIGN UNITS	THIRD ANGLE PROJECTION
	▽=0	mm INCH	MM ONLY	1:1	METRIC	
	▽=0	4 PLACES # --- # ---	DRAWN BY DATE	TITLE		
	▽=0	3 PLACES # --- # ---	SKRA JENDRANA 2011/02/14	MX123		
▽=0	2 PLACES # --- # ---	CHECKED BY DATE	66/73/80CKT			
▽=0	1 PLACE # --- # ---	MVANS LAMBROU 2011/02/14	HRNS CONN ASSY			
▽=0	0 PLACE # --- # ---	APPROVED BY DATE	molex			
ANGULAR ± ---	DRAFT WHERE APPLICABLE MUST REMAIN WITHIN DIMENSIONS	MATERIAL NO.	DOCUMENT NO.	SHEET NO.		
		SEE BOM TABLE	SD-34566-001	65 OF 85		
		THIS DRAWING CONTAINS INFORMATION THAT IS PROPRIETARY TO MOLEX INCORPORATED AND SHOULD NOT BE USED WITHOUT WRITTEN PERMISSION				

STATUS	GM PART #	MATERIAL #	PART/MATERIAL REVISION	WIRE DRESS OPTION	KEY OPTION Fp	COLOR (TPA) Fp	NUMBERS INDICATE CAVITIES OPEN FOR CIRCUITS Fp																	
AVAILABLE	NOT APPLICABLE	34566-5993	G	0	A	BLACK	71	70	69	67	66	65	63	62	61	60	58	57	56	55	54	53		
							52	51	50	49	47	45	44	43	42	41	40	39	37	36	35	34		
							73				32	31	30	29	28	27	26	25	24	23	21	20		
											16	15	14	13	12	11	10	9	8	6	5	3	1	
AVAILABLE	NOT APPLICABLE	34566-6013	G	0	B	ST.GRAY			69	67	65			61	60	59	58	57			54	53		
							51	50	49	48	47	46	45	43		40	39	37	37			34	33	
							73								26	24	23	22	21	20			18	
														10	9	8	7	6	5	4				
AVAILABLE	NOT APPLICABLE	34566-6023	G	0	A	BLACK	72	71	70	69	68	67					60	59	58	57	56		54	53
							52	51	50	49	48	47	45	44	43		40	39	38	37	36	35	34	33
							73									24	23	22	21	20	19		17	
															10	9	8	7	6	5	4	3	2	1
AVAILABLE	NOT APPLICABLE	34566-6033	G	0	A	BLACK			70	69				63	62	61			58	57	56	55	54	53
							52	51		49				44	43	42	41			37	36		34	
							73													21	19	18		
																		8		5	3			
AVAILABLE	NOT APPLICABLE	34566-6043	G	0	B	ST.GRAY				68	67	66	65	64					58			55		
																			38			35		
							73													22			19	17
															10									1
AVAILABLE	NOT APPLICABLE	34566-6053	G	0	B	ST.GRAY	72								62	61								
							52			48	47	46		43	41	40						20	19	18
							73					30										4		2
AVAILABLE	NOT APPLICABLE	34566-6063	G	0	C	BLUE			69	67	66	64	62	61	60				57			55	54	
							52	51	50	48	46	45	44	42					37			35	34	33
							73						28	27	26							19	18	17
															9									
AVAILABLE	NOT APPLICABLE	34566-6073	G	0	C	BLUE			69	67	66	64	62	61	60				57			54		
							52	51	50	49	48	46	45	44	41				37			34	33	
							73							28	27	25							18	17
															9									
AVAILABLE	NOT APPLICABLE	34566-6083	G	0	C	BLUE	72	70		68	67	66		63	62		59	57					53	
							52	51		48	47	46	44	42	40	39		37	36			34	33	
							73							26	25			22	21					
														10	9			6	5	4			2	

ENTER DESCRIPTION DEC NO: JAU2016-0232 DRAWN BY G34 CHKD: APPR:VKOSHY 2015/08/14 DESCRIPTION	QUALITY SYMBOLS	GENERAL TOLERANCES (UNLESS SPECIFIED)	DIMENSION STYLE	SCALE	DESIGN UNITS	THIRD ANGLE PROJECTION
	∇=0 ∇=0 ∇=0	mm INCH 4 PLACES ± --- ± --- 3 PLACES ± --- ± --- 2 PLACES ± --- ± --- 1 PLACE ± --- ± --- 0 PLACE ± --- ± ---	MM ONLY	1:1	METRIC	SKRA JENDRANA 2011/02/14 MVANS LAMBROU 2011/02/14
	ANGULAR ± --- DRAFT WHERE APPLICABLE MUST REMAIN WITHIN DIMENSIONS	MATERIAL NO. SEE BOM TABLE	DATE DATE DATE	TITLE MX123 66/73/80CKT HRNS CONN ASSY molex SD-34566-001	SHEET NO. 67 OF 85	

STATUS	GM PART #	MATERIAL #	PART/MATERIAL REVISION	WIRE DRESS OPTION	KEY OPTION Fp	COLOR (TPA) Fp	NUMBERS INDICATE CAVITIES OPEN FOR CIRCUITS Fp																																																																																			
AVAILABLE	NOT APPLICABLE	34566-6093	G	0	B	ST.GRAY	<table border="1"> <tr><td>72</td><td>70</td><td></td><td>67</td><td></td><td>63</td><td>62</td><td>61</td><td>60</td><td>59</td><td></td><td></td><td></td><td></td><td></td><td></td><td></td><td></td><td></td><td></td></tr> <tr><td>52</td><td></td><td></td><td></td><td>46</td><td>43</td><td>41</td><td>40</td><td></td><td></td><td></td><td></td><td></td><td></td><td></td><td></td><td>20</td><td>19</td><td>18</td><td></td></tr> <tr><td></td><td>73</td><td></td><td></td><td></td><td></td><td></td><td></td><td></td><td></td><td></td><td></td><td></td><td></td><td></td><td></td><td>4</td><td></td><td></td><td></td></tr> <tr><td></td><td></td><td>16</td><td>14</td><td></td><td>11</td><td></td><td></td><td></td><td></td><td></td><td></td><td></td><td></td><td></td><td></td><td></td><td></td><td></td><td></td></tr> </table>	72	70		67		63	62	61	60	59											52				46	43	41	40									20	19	18			73															4						16	14		11																	
72	70		67		63	62	61	60	59																																																																																	
52				46	43	41	40									20	19	18																																																																								
	73															4																																																																										
		16	14		11																																																																																					
AVAILABLE	NOT APPLICABLE	34566-6113	G	0	A	BLACK	<table border="1"> <tr><td>72</td><td>71</td><td>70</td><td>69</td><td>68</td><td>66</td><td>65</td><td>64</td><td>63</td><td>62</td><td>61</td><td>60</td><td></td><td>58</td><td>57</td><td>56</td><td>55</td><td>54</td><td>53</td><td></td></tr> <tr><td>52</td><td>51</td><td>50</td><td>49</td><td>48</td><td>46</td><td>45</td><td>44</td><td>43</td><td>42</td><td>41</td><td>40</td><td>39</td><td>38</td><td>37</td><td>36</td><td></td><td>34</td><td>33</td><td></td></tr> <tr><td></td><td>73</td><td></td><td>32</td><td>31</td><td>30</td><td>29</td><td>28</td><td>27</td><td>26</td><td>25</td><td>23</td><td>22</td><td>21</td><td>20</td><td>19</td><td>18</td><td></td><td></td><td></td></tr> <tr><td></td><td></td><td>16</td><td>15</td><td>14</td><td>13</td><td>12</td><td>11</td><td>10</td><td>9</td><td>8</td><td>7</td><td>6</td><td>5</td><td>4</td><td>3</td><td>2</td><td></td><td></td><td></td></tr> </table>	72	71	70	69	68	66	65	64	63	62	61	60		58	57	56	55	54	53		52	51	50	49	48	46	45	44	43	42	41	40	39	38	37	36		34	33			73		32	31	30	29	28	27	26	25	23	22	21	20	19	18						16	15	14	13	12	11	10	9	8	7	6	5	4	3	2						
72	71	70	69	68	66	65	64	63	62	61	60		58	57	56	55	54	53																																																																								
52	51	50	49	48	46	45	44	43	42	41	40	39	38	37	36		34	33																																																																								
	73		32	31	30	29	28	27	26	25	23	22	21	20	19	18																																																																										
		16	15	14	13	12	11	10	9	8	7	6	5	4	3	2																																																																										
AVAILABLE	NOT APPLICABLE	34566-6123	G	0	C	BLUE	<table border="1"> <tr><td></td><td></td><td>69</td><td>67</td><td>66</td><td>64</td><td>62</td><td>60</td><td></td><td></td><td>57</td><td></td><td></td><td></td><td></td><td></td><td></td><td></td><td>54</td><td></td></tr> <tr><td>52</td><td>51</td><td>50</td><td></td><td>48</td><td>46</td><td>45</td><td>44</td><td>42</td><td></td><td></td><td></td><td></td><td></td><td>37</td><td></td><td></td><td></td><td>34</td><td>33</td></tr> <tr><td></td><td>73</td><td></td><td></td><td></td><td></td><td>28</td><td>27</td><td>26</td><td></td><td></td><td></td><td></td><td></td><td></td><td></td><td></td><td></td><td></td><td></td></tr> <tr><td></td><td></td><td>16</td><td>15</td><td>14</td><td>13</td><td>12</td><td>11</td><td>10</td><td>9</td><td>8</td><td>7</td><td></td><td></td><td></td><td></td><td></td><td></td><td></td><td></td></tr> </table>			69	67	66	64	62	60			57								54		52	51	50		48	46	45	44	42						37				34	33		73					28	27	26														16	15	14	13	12	11	10	9	8	7											
		69	67	66	64	62	60			57								54																																																																								
52	51	50		48	46	45	44	42						37				34	33																																																																							
	73					28	27	26																																																																																		
		16	15	14	13	12	11	10	9	8	7																																																																															
AVAILABLE	NOT APPLICABLE	34566-6133	G	9	C	BLUE	<table border="1"> <tr><td>72</td><td>70</td><td></td><td>68</td><td>67</td><td></td><td></td><td>63</td><td>62</td><td></td><td></td><td>59</td><td></td><td>57</td><td></td><td></td><td></td><td></td><td></td><td>53</td></tr> <tr><td>52</td><td>51</td><td></td><td>48</td><td>47</td><td></td><td>44</td><td>42</td><td></td><td>40</td><td>39</td><td>38</td><td>37</td><td>36</td><td></td><td></td><td></td><td></td><td>34</td><td>33</td></tr> <tr><td></td><td>73</td><td></td><td>32</td><td>30</td><td></td><td></td><td>26</td><td>25</td><td>24</td><td></td><td>22</td><td>21</td><td></td><td></td><td></td><td></td><td></td><td></td><td></td></tr> <tr><td></td><td></td><td>15</td><td>14</td><td></td><td></td><td></td><td></td><td>9</td><td>8</td><td>7</td><td>6</td><td>5</td><td>4</td><td>3</td><td>2</td><td></td><td></td><td></td><td></td></tr> </table>	72	70		68	67			63	62			59		57						53	52	51		48	47		44	42		40	39	38	37	36					34	33		73		32	30			26	25	24		22	21										15	14					9	8	7	6	5	4	3	2							
72	70		68	67			63	62			59		57						53																																																																							
52	51		48	47		44	42		40	39	38	37	36					34	33																																																																							
	73		32	30			26	25	24		22	21																																																																														
		15	14					9	8	7	6	5	4	3	2																																																																											
AVAILABLE	NOT APPLICABLE	34566-6173	G	9	B	ST.GRAY	<table border="1"> <tr><td></td><td></td><td></td><td>67</td><td>66</td><td></td><td></td><td></td><td></td><td></td><td></td><td></td><td></td><td></td><td></td><td></td><td></td><td></td><td></td><td></td></tr> <tr><td></td><td></td><td></td><td>48</td><td>47</td><td></td><td></td><td>41</td><td></td><td></td><td></td><td></td><td></td><td></td><td></td><td></td><td></td><td></td><td>19</td><td>18</td><td>17</td></tr> <tr><td></td><td>73</td><td></td><td>32</td><td>31</td><td>30</td><td>29</td><td>27</td><td>26</td><td>25</td><td>24</td><td>22</td><td>21</td><td></td><td></td><td></td><td></td><td></td><td></td><td></td></tr> <tr><td></td><td></td><td>16</td><td>15</td><td>14</td><td>13</td><td>11</td><td>10</td><td>9</td><td>8</td><td>7</td><td>6</td><td>5</td><td>4</td><td>3</td><td>2</td><td></td><td></td><td></td><td>1</td></tr> </table>				67	66																			48	47			41											19	18	17		73		32	31	30	29	27	26	25	24	22	21										16	15	14	13	11	10	9	8	7	6	5	4	3	2				1		
			67	66																																																																																						
			48	47			41											19	18	17																																																																						
	73		32	31	30	29	27	26	25	24	22	21																																																																														
		16	15	14	13	11	10	9	8	7	6	5	4	3	2				1																																																																							
AVAILABLE	NOT APPLICABLE	34566-6183	G	9	A	BLACK	<table border="1"> <tr><td></td><td></td><td></td><td>48</td><td>47</td><td></td><td></td><td>41</td><td></td><td></td><td></td><td></td><td></td><td></td><td></td><td></td><td></td><td></td><td>19</td><td>18</td><td>17</td></tr> <tr><td></td><td>73</td><td></td><td>32</td><td>31</td><td>30</td><td>29</td><td>27</td><td>26</td><td>25</td><td>24</td><td>22</td><td>21</td><td></td><td></td><td></td><td></td><td></td><td></td><td></td></tr> <tr><td></td><td></td><td>16</td><td>15</td><td>14</td><td>13</td><td>11</td><td>10</td><td>9</td><td>8</td><td>7</td><td>6</td><td>5</td><td>4</td><td>3</td><td>2</td><td></td><td></td><td></td><td>1</td></tr> </table>				48	47			41											19	18	17		73		32	31	30	29	27	26	25	24	22	21										16	15	14	13	11	10	9	8	7	6	5	4	3	2				1																						
			48	47			41											19	18	17																																																																						
	73		32	31	30	29	27	26	25	24	22	21																																																																														
		16	15	14	13	11	10	9	8	7	6	5	4	3	2				1																																																																							
AVAILABLE	NOT APPLICABLE	34566-6193	G	9	B	ST.GRAY	<table border="1"> <tr><td>72</td><td>71</td><td>70</td><td>69</td><td>68</td><td>67</td><td>66</td><td>65</td><td>64</td><td>62</td><td>61</td><td>60</td><td>59</td><td>58</td><td>57</td><td>56</td><td>55</td><td>54</td><td></td><td></td></tr> <tr><td>52</td><td>51</td><td>50</td><td>49</td><td></td><td></td><td>46</td><td>44</td><td></td><td>41</td><td>40</td><td></td><td></td><td>38</td><td>37</td><td>36</td><td></td><td></td><td></td><td></td></tr> <tr><td></td><td>73</td><td></td><td>32</td><td>31</td><td>30</td><td>29</td><td>28</td><td>27</td><td>26</td><td>25</td><td>24</td><td></td><td>21</td><td>20</td><td></td><td></td><td></td><td>18</td><td>17</td></tr> <tr><td></td><td></td><td>16</td><td>15</td><td>14</td><td>13</td><td>12</td><td>10</td><td>9</td><td>8</td><td>7</td><td>6</td><td>5</td><td>4</td><td>3</td><td>2</td><td></td><td></td><td></td><td></td></tr> </table>	72	71	70	69	68	67	66	65	64	62	61	60	59	58	57	56	55	54			52	51	50	49			46	44		41	40			38	37	36						73		32	31	30	29	28	27	26	25	24		21	20				18	17			16	15	14	13	12	10	9	8	7	6	5	4	3	2							
72	71	70	69	68	67	66	65	64	62	61	60	59	58	57	56	55	54																																																																									
52	51	50	49			46	44		41	40			38	37	36																																																																											
	73		32	31	30	29	28	27	26	25	24		21	20				18	17																																																																							
		16	15	14	13	12	10	9	8	7	6	5	4	3	2																																																																											
AVAILABLE	NOT APPLICABLE	34566-6213	G	9	A	BLACK	<table border="1"> <tr><td></td><td></td><td></td><td>67</td><td>66</td><td></td><td></td><td></td><td></td><td></td><td></td><td></td><td></td><td></td><td></td><td></td><td></td><td></td><td></td><td></td></tr> <tr><td></td><td></td><td></td><td>48</td><td>47</td><td></td><td></td><td>41</td><td></td><td></td><td></td><td></td><td></td><td></td><td></td><td></td><td></td><td></td><td>19</td><td>18</td><td>17</td></tr> <tr><td></td><td>73</td><td></td><td>32</td><td>31</td><td>30</td><td>29</td><td>27</td><td>26</td><td>25</td><td>24</td><td>22</td><td>21</td><td></td><td></td><td></td><td></td><td></td><td></td><td></td></tr> <tr><td></td><td></td><td>16</td><td>15</td><td>14</td><td>13</td><td>11</td><td>10</td><td>9</td><td>8</td><td>7</td><td>6</td><td>5</td><td>4</td><td>3</td><td>2</td><td></td><td></td><td></td><td>1</td></tr> </table>				67	66																			48	47			41											19	18	17		73		32	31	30	29	27	26	25	24	22	21										16	15	14	13	11	10	9	8	7	6	5	4	3	2				1		
			67	66																																																																																						
			48	47			41											19	18	17																																																																						
	73		32	31	30	29	27	26	25	24	22	21																																																																														
		16	15	14	13	11	10	9	8	7	6	5	4	3	2				1																																																																							
AVAILABLE	NOT APPLICABLE	34566-6223	G	9	C	BLUE	<table border="1"> <tr><td>72</td><td>70</td><td></td><td>68</td><td>66</td><td></td><td></td><td>63</td><td>62</td><td></td><td></td><td>59</td><td></td><td>57</td><td></td><td></td><td></td><td></td><td></td><td>53</td></tr> <tr><td>52</td><td>51</td><td></td><td>48</td><td>47</td><td>46</td><td>44</td><td></td><td>40</td><td>39</td><td></td><td></td><td></td><td></td><td></td><td></td><td></td><td></td><td></td><td>34</td><td>33</td></tr> <tr><td></td><td>73</td><td></td><td>32</td><td>30</td><td></td><td></td><td>27</td><td>26</td><td>25</td><td></td><td>22</td><td>21</td><td>20</td><td></td><td></td><td></td><td></td><td></td><td></td><td></td></tr> <tr><td></td><td></td><td>15</td><td>14</td><td>13</td><td></td><td></td><td>10</td><td>9</td><td></td><td></td><td>6</td><td>5</td><td>4</td><td></td><td></td><td></td><td></td><td></td><td></td><td></td></tr> </table>	72	70		68	66			63	62			59		57						53	52	51		48	47	46	44		40	39										34	33		73		32	30			27	26	25		22	21	20										15	14	13			10	9			6	5	4							
72	70		68	66			63	62			59		57						53																																																																							
52	51		48	47	46	44		40	39										34	33																																																																						
	73		32	30			27	26	25		22	21	20																																																																													
		15	14	13			10	9			6	5	4																																																																													

ENTER DESCRIPTION DEC NO. UAU2016-0232 DRAWN BY CHKD: G34 APPR:VKOSHY 2015/08/14	QUALITY SYMBOLS	GENERAL TOLERANCES (UNLESS SPECIFIED)	DIMENSION STYLE	SCALE	DESIGN UNITS	THIRD ANGLE PROJECTION	
	∇=0 ∇=0 ∇=0	mm INCH 4 PLACES ±--- ±--- 3 PLACES ±--- ±--- 2 PLACES ±--- ±--- 1 PLACE ±--- ±--- 0 PLACE ±--- ±---	MM ONLY	1:1	METRIC	SKRA JENDRANA 2011/02/14 MYANSLAMBROU 2011/02/14	MX123 66/73/80CKT HRNS CONN ASSY molex
	ANGULAR ±---° DRAFT WHERE APPLICABLE MUST REMAIN WITHIN DIMENSIONS	MATERIAL NO. SEE BOM TABLE	DOCUMENT NO. SD-34566-001	SHEET NO. 68 OF 85			
	THIS DRAWING CONTAINS INFORMATION THAT IS PROPRIETARY TO MOLEX INCORPORATED AND SHOULD NOT BE USED WITHOUT WRITTEN PERMISSION						

STATUS	GM PART #	MATERIAL #	PART/MATERIAL REVISION	WIRE DRESS OPTION	KEY OPTION F	COLOR (TPA) F	NUMBERS INDICATE CAVITIES OPEN FOR CIRCUITS F																			
AVAILABLE	NOT APPLICABLE	34566-6233	G	9	B	ST.GRAY	72	70	68	66							60	59					55	54	53	
							52	50	48	46							40	39					35	34	33	
							73																			
																									17	
																	10	8							2	1
AVAILABLE	NOT APPLICABLE	34566-6243	G	9	A	BLACK	71	70	69					64	63			60	59	58	57	56	55	54	53	
							52	51	50	49			45	44	43	42	41		39		37	36		34		
							73																			
																									18	
																									3	
AVAILABLE	NOT APPLICABLE	34566-6253	G	9	C	BLUE	72	70	68	67	66					63	62			59		57			53	
							52	51		49	48	47	46		44				40	39		37	36		34	33
							73																			
																									2	
AVAILABLE	NOT APPLICABLE	34566-6263	G	9	B	ST.GRAY	72	71	70	68	67	66					62	61	60	59	58	57	56	55	54	53
							52	51	50								42	41	40	39	38	37	36	35	34	33
							73																			
																									18	
																									2	1
AVAILABLE	NOT APPLICABLE	34566-6273	G	9	B	ST.GRAY	71	70	69					65	64	63	62	61	60		58	57	56	55	54	53
							52	51	50	49	48	47		45	44	43	42	41		39		37	36		34	
							73																			
																									19	
																									3	
AVAILABLE	NOT APPLICABLE	34566-6283	G	9	C	BLUE	72	70	68	67	66					63	62			59		57			53	
							52	51			48	47	46		44				40	39					34	33
							73																			
																									4	
AVAILABLE	NOT APPLICABLE	34566-6293	G	9	B	ST.GRAY	72	71	70	68	67	66					62	61	60	59	58	57	56	55	54	53
							52	51	50								42	41	40	39	38	37	36	35	34	33
							73																			
																									17	
																									2	1
AVAILABLE	NOT APPLICABLE	34566-6313	G	9	B	ST.GRAY		70	69							63	62	61	60		58	57	56	55	54	53
							52	51	50	49					44	43	42	41		39		37	36		34	
							73																			
																									18	
																									3	
AVAILABLE	NOT APPLICABLE	34566-6323	G	9	B	ST.GRAY	71	70	69					64	63			60	59	58	57	56	55	54	53	
							52	51	50	49			45	44	43	42	41		39		37	36		34		
							73																			
																									19	
																									3	

ENTER DESCRIPTION DEC NO. UAU2016-0232 DRAWN BY CHKD: APPR:VKOSHY 2015/08/14 2015/08/14 2015/08/14	QUALITY SYMBOLS	GENERAL TOLERANCES (UNLESS SPECIFIED)	DIMENSION STYLE	SCALE	DESIGN UNITS	THIRD ANGLE PROJECTION
	▽=0	mm INCH	MM ONLY	1:1	METRIC	☉
	▽=0	4 PLACES ± --- ± ---	DRAWN BY SKRA JENDRANA	DATE 2011/02/14	TITLE	MX123
	▽=0	3 PLACES ± --- ± ---	CHECKED BY	DATE		66/73/80CKT
	2 PLACES ± --- ± ---	1 PLACE ± --- ± ---	APPROVED BY	DATE		HRNS CONN ASSY
	0 PLACE ± --- ± ---	ANGULAR ± ---	MATERIAL NO.	DOCUMENT NO.		molex
		DRAFT WHERE APPLICABLE MUST REMAIN WITHIN DIMENSIONS	SEE BOM TABLE			SD-34566-001
			THIS DRAWING CONTAINS INFORMATION THAT IS PROPRIETARY TO MOLEX INCORPORATED AND SHOULD NOT BE USED WITHOUT WRITTEN PERMISSION			SHEET NO. 69 OF 85

STATUS	GM PART #	MATERIAL #	PART/MATERIAL REVISION	WIRE DRESS OPTION	KEY OPTION TP	COLOR (TPA) FP	NUMBERS INDICATE CAVITIES OPEN FOR CIRCUITS FP																																																																																
AVAILABLE	NOT APPLICABLE	34566-6333	G	9	C	BLUE	<table border="1"> <tr><td>72</td><td>70</td><td>68</td><td>67</td><td>66</td><td></td><td>63</td><td>62</td><td></td><td>59</td><td>57</td><td>56</td><td>55</td><td>53</td></tr> <tr><td>52</td><td>51</td><td></td><td>48</td><td>47</td><td>46</td><td>44</td><td></td><td></td><td>40</td><td>39</td><td></td><td></td><td>34</td><td>33</td></tr> <tr><td></td><td>73</td><td></td><td>32</td><td>30</td><td></td><td>27</td><td>26</td><td>25</td><td></td><td>22</td><td>21</td><td>19</td><td>18</td></tr> <tr><td></td><td></td><td></td><td>15</td><td>14</td><td></td><td></td><td>10</td><td>9</td><td></td><td>6</td><td>5</td><td>4</td><td>3</td></tr> </table>	72	70	68	67	66		63	62		59	57	56	55	53	52	51		48	47	46	44			40	39			34	33		73		32	30		27	26	25		22	21	19	18				15	14			10	9		6	5	4	3																							
72	70	68	67	66		63	62		59	57	56	55	53																																																																										
52	51		48	47	46	44			40	39			34	33																																																																									
	73		32	30		27	26	25		22	21	19	18																																																																										
			15	14			10	9		6	5	4	3																																																																										
AVAILABLE	NOT APPLICABLE	34566-6343	G	9	A	BLACK	<table border="1"> <tr><td></td><td>70</td><td>69</td><td></td><td></td><td></td><td>63</td><td>62</td><td>61</td><td>60</td><td>58</td><td>57</td><td>56</td><td>55</td><td>54</td><td>53</td></tr> <tr><td>52</td><td>51</td><td>50</td><td>49</td><td></td><td></td><td>44</td><td>43</td><td>42</td><td>41</td><td>40</td><td>39</td><td>37</td><td>36</td><td></td><td>34</td></tr> <tr><td></td><td>73</td><td></td><td>32</td><td></td><td>29</td><td>28</td><td>27</td><td>26</td><td></td><td></td><td></td><td></td><td></td><td>19</td><td>18</td></tr> <tr><td></td><td></td><td></td><td>16</td><td>15</td><td>14</td><td>13</td><td>12</td><td>11</td><td>10</td><td></td><td></td><td></td><td></td><td>3</td><td>2</td></tr> <tr><td></td><td></td><td></td><td></td><td></td><td></td><td></td><td></td><td></td><td></td><td></td><td></td><td></td><td></td><td></td><td>1</td></tr> </table>		70	69				63	62	61	60	58	57	56	55	54	53	52	51	50	49			44	43	42	41	40	39	37	36		34		73		32		29	28	27	26						19	18				16	15	14	13	12	11	10					3	2																1
	70	69				63	62	61	60	58	57	56	55	54	53																																																																								
52	51	50	49			44	43	42	41	40	39	37	36		34																																																																								
	73		32		29	28	27	26						19	18																																																																								
			16	15	14	13	12	11	10					3	2																																																																								
															1																																																																								
AVAILABLE	NOT APPLICABLE	34566-6353	G	9	C	BLUE	<table border="1"> <tr><td>72</td><td>70</td><td>68</td><td>66</td><td></td><td></td><td>63</td><td>62</td><td></td><td>59</td><td>58</td><td>57</td><td>56</td><td>55</td><td>53</td></tr> <tr><td>52</td><td>51</td><td></td><td>48</td><td>47</td><td>46</td><td>44</td><td></td><td></td><td>40</td><td>39</td><td></td><td></td><td></td><td>34</td><td>33</td></tr> <tr><td></td><td>73</td><td></td><td>32</td><td>30</td><td></td><td>27</td><td>26</td><td>25</td><td></td><td>23</td><td>22</td><td>21</td><td>20</td><td></td><td>17</td></tr> <tr><td></td><td></td><td></td><td>15</td><td>14</td><td>13</td><td></td><td>10</td><td>9</td><td></td><td>7</td><td>6</td><td>5</td><td>4</td><td></td><td>1</td></tr> </table>	72	70	68	66			63	62		59	58	57	56	55	53	52	51		48	47	46	44			40	39				34	33		73		32	30		27	26	25		23	22	21	20		17				15	14	13		10	9		7	6	5	4		1																	
72	70	68	66			63	62		59	58	57	56	55	53																																																																									
52	51		48	47	46	44			40	39				34	33																																																																								
	73		32	30		27	26	25		23	22	21	20		17																																																																								
			15	14	13		10	9		7	6	5	4		1																																																																								
AVAILABLE	NOT APPLICABLE	34566-6363	G	9	B	ST.GRAY	<table border="1"> <tr><td>72</td><td>70</td><td>68</td><td>66</td><td></td><td></td><td></td><td></td><td></td><td>60</td><td>59</td><td></td><td></td><td></td><td>55</td><td>54</td><td>53</td></tr> <tr><td>52</td><td>51</td><td>50</td><td>49</td><td></td><td>48</td><td>46</td><td></td><td></td><td>40</td><td>39</td><td></td><td></td><td></td><td>35</td><td>34</td><td>33</td></tr> <tr><td></td><td>73</td><td></td><td>32</td><td>31</td><td>30</td><td>29</td><td>28</td><td>27</td><td>26</td><td>25</td><td>24</td><td>23</td><td></td><td>19</td><td>18</td><td>17</td></tr> <tr><td></td><td></td><td></td><td>16</td><td></td><td></td><td></td><td></td><td>10</td><td>8</td><td>7</td><td></td><td></td><td></td><td></td><td></td><td>2</td></tr> </table>	72	70	68	66						60	59				55	54	53	52	51	50	49		48	46			40	39				35	34	33		73		32	31	30	29	28	27	26	25	24	23		19	18	17				16					10	8	7						2												
72	70	68	66						60	59				55	54	53																																																																							
52	51	50	49		48	46			40	39				35	34	33																																																																							
	73		32	31	30	29	28	27	26	25	24	23		19	18	17																																																																							
			16					10	8	7						2																																																																							
AVAILABLE	NOT APPLICABLE	34566-6373	G	9	A	BLACK	<table border="1"> <tr><td>72</td><td>71</td><td>70</td><td>69</td><td></td><td>67</td><td></td><td>64</td><td>63</td><td></td><td>60</td><td>59</td><td>58</td><td>57</td><td>56</td><td>55</td><td>54</td><td>53</td></tr> <tr><td>52</td><td>51</td><td>50</td><td>49</td><td></td><td>47</td><td>45</td><td>44</td><td>43</td><td>42</td><td>41</td><td>40</td><td>39</td><td>37</td><td>36</td><td></td><td>34</td><td></td></tr> <tr><td></td><td>73</td><td></td><td>32</td><td>30</td><td>28</td><td>26</td><td></td><td></td><td></td><td>23</td><td>21</td><td></td><td></td><td>19</td><td>18</td><td>17</td><td></td></tr> <tr><td></td><td></td><td></td><td>16</td><td>15</td><td>14</td><td>12</td><td>10</td><td>8</td><td></td><td></td><td>5</td><td></td><td></td><td>3</td><td>2</td><td>1</td><td></td></tr> </table>	72	71	70	69		67		64	63		60	59	58	57	56	55	54	53	52	51	50	49		47	45	44	43	42	41	40	39	37	36		34			73		32	30	28	26				23	21			19	18	17					16	15	14	12	10	8			5			3	2	1									
72	71	70	69		67		64	63		60	59	58	57	56	55	54	53																																																																						
52	51	50	49		47	45	44	43	42	41	40	39	37	36		34																																																																							
	73		32	30	28	26				23	21			19	18	17																																																																							
			16	15	14	12	10	8			5			3	2	1																																																																							
AVAILABLE	NOT APPLICABLE	34566-6383	G	9	A	BLACK	<table border="1"> <tr><td>72</td><td>71</td><td>70</td><td>69</td><td>68</td><td>66</td><td>65</td><td>64</td><td>63</td><td>61</td><td>60</td><td></td><td></td><td>57</td><td>56</td><td></td><td>54</td><td>53</td></tr> <tr><td>52</td><td>51</td><td>50</td><td>49</td><td>48</td><td>46</td><td>45</td><td>44</td><td>43</td><td>42</td><td>41</td><td>40</td><td>39</td><td>38</td><td>37</td><td>36</td><td></td><td>34</td><td>33</td></tr> <tr><td></td><td>73</td><td></td><td>32</td><td>31</td><td>30</td><td>29</td><td>28</td><td></td><td></td><td></td><td>23</td><td>22</td><td>21</td><td></td><td></td><td></td><td></td><td></td></tr> <tr><td></td><td></td><td></td><td>15</td><td>14</td><td>13</td><td>12</td><td></td><td></td><td>9</td><td></td><td>7</td><td>6</td><td>5</td><td></td><td></td><td></td><td></td><td>2</td></tr> </table>	72	71	70	69	68	66	65	64	63	61	60			57	56		54	53	52	51	50	49	48	46	45	44	43	42	41	40	39	38	37	36		34	33		73		32	31	30	29	28				23	22	21									15	14	13	12			9		7	6	5					2					
72	71	70	69	68	66	65	64	63	61	60			57	56		54	53																																																																						
52	51	50	49	48	46	45	44	43	42	41	40	39	38	37	36		34	33																																																																					
	73		32	31	30	29	28				23	22	21																																																																										
			15	14	13	12			9		7	6	5					2																																																																					
AVAILABLE	NOT APPLICABLE	34566-6393	G	9	C	BLUE	<table border="1"> <tr><td></td><td>71</td><td>70</td><td>69</td><td>67</td><td>66</td><td>65</td><td>64</td><td></td><td>62</td><td>61</td><td>60</td><td></td><td>58</td><td>57</td><td></td><td>55</td><td>54</td></tr> <tr><td>52</td><td>51</td><td>50</td><td>49</td><td>48</td><td>47</td><td>46</td><td>45</td><td>44</td><td>42</td><td>41</td><td></td><td></td><td>38</td><td>37</td><td></td><td>35</td><td>34</td><td>33</td></tr> <tr><td></td><td>73</td><td></td><td>32</td><td></td><td></td><td>28</td><td>27</td><td>26</td><td>25</td><td></td><td></td><td></td><td></td><td></td><td></td><td>19</td><td>18</td><td>17</td></tr> <tr><td></td><td></td><td></td><td>16</td><td>15</td><td>14</td><td>13</td><td>12</td><td>11</td><td>10</td><td>9</td><td></td><td></td><td></td><td></td><td></td><td></td><td></td><td></td></tr> </table>		71	70	69	67	66	65	64		62	61	60		58	57		55	54	52	51	50	49	48	47	46	45	44	42	41			38	37		35	34	33		73		32			28	27	26	25							19	18	17				16	15	14	13	12	11	10	9													
	71	70	69	67	66	65	64		62	61	60		58	57		55	54																																																																						
52	51	50	49	48	47	46	45	44	42	41			38	37		35	34	33																																																																					
	73		32			28	27	26	25							19	18	17																																																																					
			16	15	14	13	12	11	10	9																																																																													
AVAILABLE	NOT APPLICABLE	34566-6413	G	9	B	ST.GRAY	<table border="1"> <tr><td>72</td><td></td><td></td><td>68</td><td>67</td><td></td><td></td><td>63</td><td>62</td><td>61</td><td>60</td><td>59</td><td></td><td></td><td></td><td>55</td><td></td><td></td></tr> <tr><td>52</td><td></td><td></td><td>48</td><td>47</td><td>46</td><td></td><td>44</td><td>43</td><td>41</td><td>40</td><td></td><td>38</td><td>37</td><td>36</td><td>35</td><td></td><td></td></tr> <tr><td></td><td>73</td><td></td><td></td><td>30</td><td></td><td></td><td>27</td><td></td><td></td><td></td><td></td><td></td><td></td><td></td><td>20</td><td>19</td><td>18</td><td>17</td></tr> <tr><td></td><td></td><td></td><td>16</td><td>15</td><td>14</td><td></td><td>11</td><td></td><td></td><td>8</td><td></td><td></td><td></td><td>4</td><td></td><td></td><td></td><td>1</td></tr> </table>	72			68	67			63	62	61	60	59				55			52			48	47	46		44	43	41	40		38	37	36	35				73			30			27								20	19	18	17				16	15	14		11			8				4				1						
72			68	67			63	62	61	60	59				55																																																																								
52			48	47	46		44	43	41	40		38	37	36	35																																																																								
	73			30			27								20	19	18	17																																																																					
			16	15	14		11			8				4				1																																																																					
AVAILABLE	NOT APPLICABLE	34566-6423	G	9	C	BLUE	<table border="1"> <tr><td>72</td><td>71</td><td>70</td><td>69</td><td>67</td><td>66</td><td>65</td><td>64</td><td></td><td></td><td></td><td></td><td></td><td></td><td>56</td><td></td><td>54</td><td></td></tr> <tr><td>52</td><td>51</td><td>50</td><td>49</td><td>47</td><td>46</td><td>45</td><td>44</td><td></td><td></td><td></td><td>39</td><td>38</td><td></td><td></td><td></td><td>34</td><td></td></tr> <tr><td></td><td>73</td><td></td><td>31</td><td>30</td><td>29</td><td>28</td><td></td><td>26</td><td>25</td><td></td><td>23</td><td>22</td><td>21</td><td></td><td></td><td></td><td>17</td></tr> <tr><td></td><td></td><td></td><td>16</td><td>15</td><td>14</td><td>13</td><td>12</td><td></td><td>9</td><td></td><td>7</td><td>6</td><td>5</td><td></td><td></td><td></td><td></td></tr> </table>	72	71	70	69	67	66	65	64							56		54		52	51	50	49	47	46	45	44				39	38				34			73		31	30	29	28		26	25		23	22	21				17				16	15	14	13	12		9		7	6	5												
72	71	70	69	67	66	65	64							56		54																																																																							
52	51	50	49	47	46	45	44				39	38				34																																																																							
	73		31	30	29	28		26	25		23	22	21				17																																																																						
			16	15	14	13	12		9		7	6	5																																																																										

ENTER DESCRIPTION DEC NO. UAU2016-0232 DRAWN BY G34 CHKD: APPR:VKOSHY 2015/08/14 2015/08/14	QUALITY SYMBOLS	GENERAL TOLERANCES (UNLESS SPECIFIED)	DIMENSION STYLE	SCALE	DESIGN UNITS	THIRD ANGLE PROJECTION	
	∇=0 ∇=0 ∇=0	mm INCH 4 PLACES # --- # --- 3 PLACES # --- # --- 2 PLACES # --- # --- 1 PLACE # --- # --- 0 PLACE # --- # ---	MM ONLY	1:1	METRIC	DRAWN BY DATE SKRA JENDRANA 2011/02/14 CHECKED BY DATE MVANSLAMBROU 2011/02/14 APPROVED BY DATE	MX123 66/73/80CKT HRNS CONN ASSY molex
	ANGULAR ± --- DRAFT WHERE APPLICABLE MUST REMAIN WITHIN DIMENSIONS	MATERIAL NO. SEE BOM TABLE SIZE D	DOCUMENT NO. SD-34566-001	SHEET NO. 70 OF 85			
	THIS DRAWING CONTAINS INFORMATION THAT IS PROPRIETARY TO MOLEX INCORPORATED AND SHOULD NOT BE USED WITHOUT WRITTEN PERMISSION						

STATUS	GM PART #	MATERIAL #	PART/MATERIAL REVISION	WIRE DRESS OPTION	KEY OPTION Fp	COLOR (TPA) Fp	NUMBERS INDICATE CAVITIES OPEN FOR CIRCUITS Fp																																																																																			
AVAILABLE	NOT APPLICABLE	34566-6433	G	9	A	BLACK	<table border="1"> <tr><td>72</td><td>70</td><td></td><td>67</td><td></td><td></td><td>63</td><td></td><td>60</td><td>59</td><td>58</td><td>57</td><td>56</td><td>55</td><td></td><td></td></tr> <tr><td>52</td><td>51</td><td></td><td>48</td><td>47</td><td>46</td><td></td><td>43</td><td>42</td><td>40</td><td>39</td><td>38</td><td>37</td><td>36</td><td>35</td><td></td></tr> <tr><td colspan="2">73</td><td></td><td></td><td></td><td></td><td>28</td><td>27</td><td></td><td></td><td>22</td><td>21</td><td></td><td></td><td>18</td><td>17</td></tr> <tr><td colspan="2"></td><td></td><td></td><td></td><td></td><td>12</td><td>11</td><td>9</td><td>7</td><td></td><td></td><td></td><td></td><td></td><td>2</td></tr> </table>	72	70		67			63		60	59	58	57	56	55			52	51		48	47	46		43	42	40	39	38	37	36	35		73						28	27			22	21			18	17							12	11	9	7						2																			
72	70		67			63		60	59	58	57	56	55																																																																													
52	51		48	47	46		43	42	40	39	38	37	36	35																																																																												
73						28	27			22	21			18	17																																																																											
						12	11	9	7						2																																																																											
AVAILABLE	NOT APPLICABLE	34566-6443	G	9	B	ST.GRAY	<table border="1"> <tr><td>72</td><td>71</td><td>70</td><td>69</td><td>68</td><td>67</td><td>66</td><td>65</td><td>64</td><td>63</td><td>61</td><td>60</td><td></td><td>57</td><td>56</td><td>55</td><td></td></tr> <tr><td>52</td><td>51</td><td>50</td><td>49</td><td>48</td><td>47</td><td>46</td><td>45</td><td>44</td><td>43</td><td>41</td><td>40</td><td></td><td>38</td><td>37</td><td>36</td><td>35</td><td>34</td><td>33</td></tr> <tr><td colspan="2">73</td><td></td><td>32</td><td>31</td><td>30</td><td>29</td><td>28</td><td></td><td>26</td><td>25</td><td>24</td><td>23</td><td>22</td><td>21</td><td>20</td><td>19</td><td>18</td><td>17</td></tr> <tr><td colspan="2"></td><td></td><td>16</td><td>15</td><td>14</td><td>13</td><td>12</td><td>11</td><td></td><td>9</td><td>8</td><td>7</td><td>6</td><td>5</td><td>4</td><td>3</td><td>2</td><td>1</td></tr> </table>	72	71	70	69	68	67	66	65	64	63	61	60		57	56	55		52	51	50	49	48	47	46	45	44	43	41	40		38	37	36	35	34	33	73			32	31	30	29	28		26	25	24	23	22	21	20	19	18	17				16	15	14	13	12	11		9	8	7	6	5	4	3	2	1									
72	71	70	69	68	67	66	65	64	63	61	60		57	56	55																																																																											
52	51	50	49	48	47	46	45	44	43	41	40		38	37	36	35	34	33																																																																								
73			32	31	30	29	28		26	25	24	23	22	21	20	19	18	17																																																																								
			16	15	14	13	12	11		9	8	7	6	5	4	3	2	1																																																																								
AVAILABLE	NOT APPLICABLE	34566-6453	G	0	C	BLUE	<table border="1"> <tr><td></td><td>71</td><td>70</td><td>69</td><td></td><td>67</td><td></td><td>65</td><td>64</td><td></td><td>62</td><td>61</td><td>60</td><td></td><td>57</td><td></td><td></td><td>54</td></tr> <tr><td>52</td><td>51</td><td>50</td><td>49</td><td>48</td><td>47</td><td>46</td><td>45</td><td>44</td><td></td><td>42</td><td>41</td><td></td><td></td><td>37</td><td></td><td></td><td>34</td><td>33</td></tr> <tr><td colspan="2">73</td><td></td><td></td><td>32</td><td></td><td></td><td></td><td>28</td><td>27</td><td>26</td><td>25</td><td></td><td></td><td></td><td></td><td></td><td>18</td><td>17</td></tr> <tr><td colspan="2"></td><td></td><td></td><td>16</td><td>15</td><td>14</td><td>13</td><td>12</td><td>11</td><td>10</td><td>9</td><td>8</td><td>7</td><td></td><td></td><td></td><td></td><td></td></tr> </table>		71	70	69		67		65	64		62	61	60		57			54	52	51	50	49	48	47	46	45	44		42	41			37			34	33	73				32				28	27	26	25						18	17					16	15	14	13	12	11	10	9	8	7													
	71	70	69		67		65	64		62	61	60		57			54																																																																									
52	51	50	49	48	47	46	45	44		42	41			37			34	33																																																																								
73				32				28	27	26	25						18	17																																																																								
				16	15	14	13	12	11	10	9	8	7																																																																													
AVAILABLE	NOT APPLICABLE	34566-6463	G	0	B	ST.GRAY	<table border="1"> <tr><td>72</td><td></td><td></td><td>68</td><td>67</td><td></td><td></td><td></td><td></td><td></td><td>62</td><td>61</td><td></td><td></td><td></td><td></td><td></td><td>55</td><td></td></tr> <tr><td>52</td><td></td><td></td><td>48</td><td>47</td><td>46</td><td></td><td></td><td></td><td>43</td><td></td><td>40</td><td></td><td></td><td></td><td></td><td></td><td>20</td><td>19</td><td>18</td></tr> <tr><td colspan="2">73</td><td></td><td></td><td></td><td>30</td><td></td><td></td><td></td><td></td><td></td><td></td><td></td><td></td><td></td><td></td><td></td><td>4</td><td></td><td>2</td></tr> <tr><td colspan="2"></td><td></td><td></td><td></td><td>16</td><td>15</td><td>14</td><td></td><td></td><td></td><td>8</td><td></td><td></td><td></td><td></td><td></td><td></td><td></td><td></td></tr> </table>	72			68	67						62	61						55		52			48	47	46				43		40						20	19	18	73					30												4		2						16	15	14				8												
72			68	67						62	61						55																																																																									
52			48	47	46				43		40						20	19	18																																																																							
73					30												4		2																																																																							
					16	15	14				8																																																																															
AVAILABLE	NOT APPLICABLE	34566-6473	G	9	C	BLUE	<table border="1"> <tr><td></td><td>70</td><td>69</td><td></td><td>67</td><td>66</td><td></td><td>64</td><td></td><td>62</td><td>60</td><td></td><td></td><td>57</td><td></td><td>55</td><td>54</td><td></td></tr> <tr><td>52</td><td>51</td><td>50</td><td></td><td>48</td><td>46</td><td>45</td><td>44</td><td></td><td>42</td><td></td><td></td><td></td><td>37</td><td></td><td>35</td><td>34</td><td>33</td></tr> <tr><td colspan="2">73</td><td></td><td></td><td>32</td><td></td><td></td><td></td><td>28</td><td>27</td><td>26</td><td></td><td></td><td></td><td></td><td>19</td><td>18</td><td>17</td></tr> <tr><td colspan="2"></td><td></td><td></td><td>16</td><td>15</td><td>14</td><td>13</td><td>12</td><td>11</td><td>10</td><td>9</td><td>8</td><td>7</td><td></td><td></td><td></td><td></td><td></td></tr> </table>		70	69		67	66		64		62	60			57		55	54		52	51	50		48	46	45	44		42				37		35	34	33	73				32				28	27	26					19	18	17					16	15	14	13	12	11	10	9	8	7															
	70	69		67	66		64		62	60			57		55	54																																																																										
52	51	50		48	46	45	44		42				37		35	34	33																																																																									
73				32				28	27	26					19	18	17																																																																									
				16	15	14	13	12	11	10	9	8	7																																																																													
AVAILABLE	NOT APPLICABLE	34566-6483	G	9	A	BLACK	<table border="1"> <tr><td>72</td><td>71</td><td>70</td><td>69</td><td>68</td><td></td><td>66</td><td>65</td><td>64</td><td>63</td><td>61</td><td>60</td><td></td><td>57</td><td>56</td><td></td><td>54</td><td>53</td></tr> <tr><td>52</td><td>51</td><td>50</td><td>49</td><td>48</td><td></td><td>46</td><td>45</td><td>44</td><td>43</td><td></td><td>40</td><td>39</td><td>38</td><td>37</td><td>36</td><td></td><td>34</td><td>33</td></tr> <tr><td colspan="2">73</td><td></td><td></td><td>32</td><td>31</td><td>30</td><td>29</td><td>28</td><td></td><td>26</td><td>25</td><td></td><td>23</td><td>22</td><td>21</td><td>20</td><td></td><td></td></tr> <tr><td colspan="2"></td><td></td><td></td><td></td><td>15</td><td>14</td><td>13</td><td>12</td><td></td><td>9</td><td>7</td><td>6</td><td>5</td><td></td><td></td><td></td><td></td><td>2</td></tr> </table>	72	71	70	69	68		66	65	64	63	61	60		57	56		54	53	52	51	50	49	48		46	45	44	43		40	39	38	37	36		34	33	73				32	31	30	29	28		26	25		23	22	21	20								15	14	13	12		9	7	6	5					2								
72	71	70	69	68		66	65	64	63	61	60		57	56		54	53																																																																									
52	51	50	49	48		46	45	44	43		40	39	38	37	36		34	33																																																																								
73				32	31	30	29	28		26	25		23	22	21	20																																																																										
					15	14	13	12		9	7	6	5					2																																																																								
AVAILABLE	NOT APPLICABLE	34566-6493	G	9	B	ST.GRAY	<table border="1"> <tr><td>72</td><td></td><td>70</td><td></td><td></td><td></td><td></td><td></td><td></td><td></td><td>62</td><td>61</td><td></td><td></td><td></td><td></td><td></td><td></td><td>55</td><td></td></tr> <tr><td>52</td><td></td><td></td><td>48</td><td>47</td><td>46</td><td></td><td></td><td></td><td>43</td><td></td><td>41</td><td>40</td><td></td><td></td><td></td><td></td><td></td><td>20</td><td>19</td><td>18</td></tr> <tr><td colspan="2">73</td><td></td><td></td><td></td><td></td><td>30</td><td></td><td></td><td></td><td></td><td></td><td></td><td></td><td></td><td></td><td></td><td></td><td>4</td><td></td><td>2</td></tr> <tr><td colspan="2"></td><td></td><td></td><td></td><td></td><td>16</td><td>15</td><td>14</td><td></td><td></td><td></td><td></td><td></td><td></td><td></td><td></td><td></td><td></td><td></td><td></td></tr> </table>	72		70								62	61							55		52			48	47	46				43		41	40						20	19	18	73						30												4		2							16	15	14												
72		70								62	61							55																																																																								
52			48	47	46				43		41	40						20	19	18																																																																						
73						30												4		2																																																																						
						16	15	14																																																																																		
AVAILABLE	NOT APPLICABLE	34566-6513	G	0	B	ST.GRAY	<table border="1"> <tr><td>72</td><td></td><td></td><td>68</td><td>67</td><td></td><td></td><td></td><td></td><td></td><td>62</td><td>61</td><td></td><td></td><td></td><td></td><td></td><td></td><td>55</td><td>54</td></tr> <tr><td>52</td><td></td><td></td><td></td><td>46</td><td></td><td></td><td></td><td></td><td>43</td><td></td><td>40</td><td></td><td></td><td></td><td></td><td></td><td></td><td>20</td><td>19</td><td>18</td></tr> <tr><td colspan="2">73</td><td></td><td></td><td></td><td></td><td></td><td></td><td></td><td></td><td></td><td></td><td></td><td></td><td></td><td></td><td></td><td></td><td>4</td><td>3</td><td>2</td></tr> <tr><td colspan="2"></td><td></td><td></td><td></td><td></td><td>16</td><td>15</td><td>14</td><td></td><td></td><td>8</td><td></td><td></td><td></td><td></td><td></td><td></td><td></td><td></td><td></td></tr> </table>	72			68	67						62	61							55	54	52				46					43		40							20	19	18	73																		4	3	2							16	15	14			8									
72			68	67						62	61							55	54																																																																							
52				46					43		40							20	19	18																																																																						
73																		4	3	2																																																																						
						16	15	14			8																																																																															
AVAILABLE	NOT APPLICABLE	34566-6523	G	0	B	ST.GRAY	<table border="1"> <tr><td></td><td></td><td></td><td>68</td><td>67</td><td></td><td></td><td></td><td></td><td></td><td></td><td></td><td></td><td>59</td><td>58</td><td></td><td></td><td></td><td>54</td><td></td></tr> <tr><td></td><td></td><td></td><td></td><td>46</td><td>45</td><td></td><td></td><td></td><td></td><td></td><td></td><td></td><td>39</td><td>38</td><td></td><td></td><td></td><td></td><td></td></tr> <tr><td colspan="2">73</td><td></td><td>32</td><td></td><td>30</td><td>29</td><td>28</td><td>27</td><td></td><td></td><td></td><td></td><td>23</td><td>22</td><td></td><td></td><td></td><td></td><td>17</td></tr> <tr><td colspan="2"></td><td></td><td></td><td></td><td>15</td><td>14</td><td>13</td><td>11</td><td>10</td><td></td><td></td><td></td><td>6</td><td></td><td></td><td></td><td></td><td></td><td>1</td></tr> </table>				68	67									59	58				54						46	45								39	38						73			32		30	29	28	27					23	22					17						15	14	13	11	10				6						1			
			68	67									59	58				54																																																																								
				46	45								39	38																																																																												
73			32		30	29	28	27					23	22					17																																																																							
					15	14	13	11	10				6						1																																																																							

ENTER DESCRIPTION DEC NO. UAU2016-0232 DRAWN BY CHKD: APPR:VKOSHY 2015/08/14 2015/08/14	QUALITY SYMBOLS	GENERAL TOLERANCES (UNLESS SPECIFIED)	DIMENSION STYLE	SCALE	DESIGN UNITS	THIRD ANGLE PROJECTION	
	∇=0 ∇=0 ∇=0	mm INCH 4 PLACES # --- ± --- 3 PLACES # --- ± --- 2 PLACES # --- ± --- 1 PLACE # --- ± --- 0 PLACE # --- ± ---	MM ONLY	1:1	METRIC	SKRA JENDRANA 2011/02/14 MYANSLAMBROU 2011/02/14	MX123 66/73/80CKT HRNS CONN ASSY molex
	ANGULAR ± ---° DRAFT WHERE APPLICABLE MUST REMAIN WITHIN DIMENSIONS	MATERIAL NO. SEE BOM TABLE	DOCUMENT NO. SD-34566-001	SHEET NO. 71 OF 85			
	THIS DRAWING CONTAINS INFORMATION THAT IS PROPRIETARY TO MOLEX INCORPORATED AND SHOULD NOT BE USED WITHOUT WRITTEN PERMISSION						

STATUS	GM PART #	MATERIAL #	PART/ MATERIAL REVISION	WIRE DRESS OPTION	KEY OPTION FP	COLOR (TPA) FP	NUMBERS INDICATE CAVITIES OPEN FOR CIRCUITS FP																																																																																																		
AVAILABLE	NOT APPLICABLE	34566-6633	G	9	C	BLUE	<table border="1"> <tr><td></td><td></td><td>69</td><td>67</td><td>66</td><td>64</td><td>62</td><td>60</td><td></td><td>57</td><td></td><td>54</td></tr> <tr><td>52</td><td>51</td><td>50</td><td>48</td><td>46</td><td>45</td><td>44</td><td>42</td><td></td><td>37</td><td></td><td>34</td><td>33</td></tr> <tr><td colspan="12">73</td></tr> <tr><td></td><td></td><td>16</td><td>15</td><td>14</td><td>13</td><td>12</td><td>11</td><td>10</td><td>9</td><td>8</td><td>7</td><td></td></tr> </table>			69	67	66	64	62	60		57		54	52	51	50	48	46	45	44	42		37		34	33	73														16	15	14	13	12	11	10	9	8	7																																																	
		69	67	66	64	62	60		57		54																																																																																														
52	51	50	48	46	45	44	42		37		34	33																																																																																													
73																																																																																																									
		16	15	14	13	12	11	10	9	8	7																																																																																														
AVAILABLE	NOT APPLICABLE	34566-6643	G	9	C	BLUE	<table border="1"> <tr><td></td><td>71</td><td></td><td>68</td><td>67</td><td>65</td><td>64</td><td>63</td><td>61</td><td>60</td><td>58</td><td>57</td><td></td><td>54</td></tr> <tr><td>52</td><td>51</td><td>50</td><td>48</td><td></td><td>45</td><td>43</td><td>41</td><td>40</td><td></td><td>38</td><td>37</td><td></td><td>34</td><td>33</td></tr> <tr><td colspan="15">73</td></tr> <tr><td></td><td></td><td>16</td><td>15</td><td>14</td><td>13</td><td>12</td><td>11</td><td>10</td><td>9</td><td>8</td><td>7</td><td></td><td></td><td></td></tr> </table>		71		68	67	65	64	63	61	60	58	57		54	52	51	50	48		45	43	41	40		38	37		34	33	73																	16	15	14	13	12	11	10	9	8	7																																										
	71		68	67	65	64	63	61	60	58	57		54																																																																																												
52	51	50	48		45	43	41	40		38	37		34	33																																																																																											
73																																																																																																									
		16	15	14	13	12	11	10	9	8	7																																																																																														
AVAILABLE	NOT APPLICABLE	34566-6653	G	9	B	ST.GRAY	<table border="1"> <tr><td>72</td><td></td><td></td><td>68</td><td></td><td></td><td></td><td></td><td>62</td><td>61</td><td>60</td><td>59</td><td></td><td></td><td>55</td><td></td></tr> <tr><td>52</td><td></td><td></td><td>48</td><td>47</td><td>46</td><td></td><td>44</td><td>43</td><td>41</td><td>40</td><td></td><td>38</td><td>37</td><td>36</td><td>35</td></tr> <tr><td colspan="16">73</td></tr> <tr><td></td><td></td><td></td><td></td><td>30</td><td></td><td></td><td></td><td></td><td></td><td></td><td>8</td><td></td><td></td><td>20</td><td>19</td><td>18</td></tr> <tr><td></td><td></td><td></td><td>16</td><td>14</td><td></td><td></td><td></td><td></td><td></td><td></td><td></td><td></td><td>5</td><td>4</td><td></td><td>1</td></tr> </table>	72			68					62	61	60	59			55		52			48	47	46		44	43	41	40		38	37	36	35	73																				30							8			20	19	18				16	14									5	4		1																
72			68					62	61	60	59			55																																																																																											
52			48	47	46		44	43	41	40		38	37	36	35																																																																																										
73																																																																																																									
				30							8			20	19	18																																																																																									
			16	14									5	4		1																																																																																									
AVAILABLE	NOT APPLICABLE	34566-6663	G	9	A	BLACK	<table border="1"> <tr><td>72</td><td>71</td><td>70</td><td>69</td><td>68</td><td>66</td><td>65</td><td>64</td><td>63</td><td></td><td>60</td><td></td><td>57</td><td>56</td><td>54</td></tr> <tr><td>52</td><td>51</td><td>50</td><td>49</td><td>48</td><td>46</td><td>45</td><td>44</td><td>43</td><td>42</td><td>40</td><td>39</td><td>38</td><td>37</td><td>36</td><td>34</td></tr> <tr><td colspan="16">73</td></tr> <tr><td></td><td></td><td></td><td>32</td><td>31</td><td>30</td><td>29</td><td>28</td><td>26</td><td>25</td><td>24</td><td>23</td><td>22</td><td>21</td><td>20</td><td></td><td></td></tr> <tr><td></td><td></td><td></td><td></td><td>15</td><td>14</td><td>13</td><td>12</td><td></td><td>9</td><td>7</td><td>6</td><td>5</td><td>4</td><td>2</td><td></td><td></td></tr> </table>	72	71	70	69	68	66	65	64	63		60		57	56	54	52	51	50	49	48	46	45	44	43	42	40	39	38	37	36	34	73																			32	31	30	29	28	26	25	24	23	22	21	20							15	14	13	12		9	7	6	5	4	2																			
72	71	70	69	68	66	65	64	63		60		57	56	54																																																																																											
52	51	50	49	48	46	45	44	43	42	40	39	38	37	36	34																																																																																										
73																																																																																																									
			32	31	30	29	28	26	25	24	23	22	21	20																																																																																											
				15	14	13	12		9	7	6	5	4	2																																																																																											
AVAILABLE	NOT APPLICABLE	34566-6673	G	9	B	ST.GRAY	<table border="1"> <tr><td>72</td><td>71</td><td>70</td><td>69</td><td>68</td><td>67</td><td>66</td><td>65</td><td>64</td><td>63</td><td>61</td><td>60</td><td>59</td><td>57</td><td>56</td><td>55</td><td></td></tr> <tr><td>52</td><td>51</td><td>50</td><td>49</td><td>48</td><td>47</td><td>46</td><td>45</td><td>44</td><td>43</td><td>41</td><td>40</td><td>39</td><td>38</td><td>37</td><td>36</td><td>35</td><td>34</td><td>33</td></tr> <tr><td colspan="19">73</td></tr> <tr><td></td><td></td><td></td><td>32</td><td>31</td><td>30</td><td>29</td><td>28</td><td></td><td>26</td><td>24</td><td>23</td><td>22</td><td>21</td><td>20</td><td>19</td><td>18</td><td>17</td><td>1</td></tr> <tr><td></td><td></td><td></td><td></td><td>16</td><td>15</td><td>14</td><td>13</td><td>12</td><td>11</td><td>9</td><td>8</td><td>7</td><td>6</td><td>5</td><td>4</td><td>3</td><td>2</td><td>1</td></tr> </table>	72	71	70	69	68	67	66	65	64	63	61	60	59	57	56	55		52	51	50	49	48	47	46	45	44	43	41	40	39	38	37	36	35	34	33	73																						32	31	30	29	28		26	24	23	22	21	20	19	18	17	1					16	15	14	13	12	11	9	8	7	6	5	4	3	2	1					
72	71	70	69	68	67	66	65	64	63	61	60	59	57	56	55																																																																																										
52	51	50	49	48	47	46	45	44	43	41	40	39	38	37	36	35	34	33																																																																																							
73																																																																																																									
			32	31	30	29	28		26	24	23	22	21	20	19	18	17	1																																																																																							
				16	15	14	13	12	11	9	8	7	6	5	4	3	2	1																																																																																							
AVAILABLE	NOT APPLICABLE	34566-6683	G	9	A	BLACK	<table border="1"> <tr><td>72</td><td></td><td>70</td><td></td><td>67</td><td></td><td></td><td></td><td>63</td><td></td><td>60</td><td>59</td><td>58</td><td>57</td><td></td><td></td><td></td><td></td><td></td></tr> <tr><td>52</td><td></td><td></td><td></td><td>48</td><td>47</td><td>46</td><td></td><td>43</td><td>42</td><td>40</td><td>39</td><td>38</td><td>37</td><td></td><td></td><td></td><td></td><td></td></tr> <tr><td colspan="19">73</td></tr> <tr><td></td><td></td><td></td><td></td><td>32</td><td>31</td><td>30</td><td>29</td><td>28</td><td>27</td><td></td><td></td><td></td><td>22</td><td>21</td><td></td><td></td><td></td><td></td></tr> <tr><td></td><td></td><td></td><td></td><td>16</td><td>15</td><td>14</td><td>13</td><td>12</td><td>11</td><td>9</td><td></td><td></td><td>6</td><td></td><td></td><td></td><td></td><td>2</td><td>1</td></tr> </table>	72		70		67				63		60	59	58	57						52				48	47	46		43	42	40	39	38	37						73																							32	31	30	29	28	27				22	21									16	15	14	13	12	11	9			6					2	1		
72		70		67				63		60	59	58	57																																																																																												
52				48	47	46		43	42	40	39	38	37																																																																																												
73																																																																																																									
				32	31	30	29	28	27				22	21																																																																																											
				16	15	14	13	12	11	9			6					2	1																																																																																						
AVAILABLE	NOT APPLICABLE	34566-6693	G	9	C	BLUE	<table border="1"> <tr><td>72</td><td>71</td><td>70</td><td>69</td><td>67</td><td>66</td><td>65</td><td>64</td><td></td><td></td><td></td><td></td><td></td><td></td><td>56</td><td>54</td></tr> <tr><td>52</td><td>51</td><td>50</td><td>49</td><td>47</td><td>46</td><td>45</td><td>44</td><td></td><td></td><td></td><td></td><td>39</td><td>38</td><td></td><td>34</td></tr> <tr><td colspan="16">73</td></tr> <tr><td></td><td></td><td></td><td></td><td>31</td><td>30</td><td>29</td><td>28</td><td></td><td>26</td><td>25</td><td>24</td><td>23</td><td>22</td><td>21</td><td></td><td>17</td></tr> <tr><td></td><td></td><td></td><td></td><td>16</td><td>15</td><td>14</td><td>13</td><td>12</td><td></td><td>9</td><td>8</td><td>7</td><td>6</td><td>5</td><td></td><td></td></tr> </table>	72	71	70	69	67	66	65	64							56	54	52	51	50	49	47	46	45	44					39	38		34	73																				31	30	29	28		26	25	24	23	22	21		17					16	15	14	13	12		9	8	7	6	5																		
72	71	70	69	67	66	65	64							56	54																																																																																										
52	51	50	49	47	46	45	44					39	38		34																																																																																										
73																																																																																																									
				31	30	29	28		26	25	24	23	22	21		17																																																																																									
				16	15	14	13	12		9	8	7	6	5																																																																																											
AVAILABLE	NOT APPLICABLE	34822-0063	A	9	A	BLACK	<table border="1"> <tr><td></td><td>63</td><td>62</td><td>61</td><td>60</td><td>59</td><td></td><td></td><td></td><td></td><td>54</td><td>53</td><td></td><td>51</td><td>49</td><td></td><td></td><td></td><td></td></tr> <tr><td></td><td>47</td><td></td><td></td><td></td><td></td><td></td><td></td><td></td><td></td><td>38</td><td>37</td><td></td><td>35</td><td>33</td><td></td><td>66</td><td></td><td></td></tr> <tr><td colspan="19">65</td></tr> <tr><td></td><td></td><td></td><td></td><td></td><td></td><td></td><td></td><td></td><td></td><td></td><td></td><td></td><td></td><td>22</td><td>21</td><td>20</td><td>19</td><td>18</td><td>17</td></tr> <tr><td></td><td></td><td></td><td></td><td></td><td></td><td></td><td></td><td></td><td></td><td></td><td></td><td></td><td></td><td>8</td><td>7</td><td></td><td></td><td>3</td><td>2</td><td>1</td></tr> </table>		63	62	61	60	59					54	53		51	49						47									38	37		35	33		66			65																																	22	21	20	19	18	17															8	7			3	2	1
	63	62	61	60	59					54	53		51	49																																																																																											
	47									38	37		35	33		66																																																																																									
65																																																																																																									
														22	21	20	19	18	17																																																																																						
														8	7			3	2	1																																																																																					
AVAILABLE	NOT APPLICABLE	34566-6713	G	9	A	BLACK	<table border="1"> <tr><td>72</td><td>71</td><td>70</td><td>69</td><td>68</td><td>66</td><td>65</td><td>64</td><td>63</td><td>61</td><td>60</td><td></td><td>57</td><td>56</td><td>54</td><td>53</td></tr> <tr><td>52</td><td>51</td><td>50</td><td>49</td><td>48</td><td>46</td><td>45</td><td>44</td><td>43</td><td>42</td><td>41</td><td>40</td><td>39</td><td>38</td><td>37</td><td>36</td><td>34</td><td>33</td></tr> <tr><td colspan="17">73</td></tr> <tr><td></td><td></td><td></td><td>32</td><td>31</td><td>30</td><td>29</td><td>28</td><td></td><td>26</td><td>25</td><td></td><td>23</td><td>22</td><td>21</td><td></td><td></td><td></td></tr> <tr><td></td><td></td><td></td><td></td><td>15</td><td>14</td><td>13</td><td>12</td><td></td><td>9</td><td>7</td><td>6</td><td>5</td><td></td><td></td><td></td><td></td><td>2</td><td>1</td></tr> </table>	72	71	70	69	68	66	65	64	63	61	60		57	56	54	53	52	51	50	49	48	46	45	44	43	42	41	40	39	38	37	36	34	33	73																				32	31	30	29	28		26	25		23	22	21								15	14	13	12		9	7	6	5					2	1										
72	71	70	69	68	66	65	64	63	61	60		57	56	54	53																																																																																										
52	51	50	49	48	46	45	44	43	42	41	40	39	38	37	36	34	33																																																																																								
73																																																																																																									
			32	31	30	29	28		26	25		23	22	21																																																																																											
				15	14	13	12		9	7	6	5					2	1																																																																																							

ENTER DESCRIPTION ELEC NO: UAU2016-0232 DRAWN BY: G34 CHKD: APPR: WKSHY 2015/08/14 2015/08/14 DESCRIPTION	QUALITY SYMBOLS	GENERAL TOLERANCES (UNLESS SPECIFIED)	DIMENSION STYLE	SCALE	DESIGN UNITS	THIRD ANGLE PROJECTION
	∇=0 ∇=0 ∇=0	mm INCH 4 PLACES # --- ± --- 3 PLACES # --- ± --- 2 PLACES # --- ± --- 1 PLACE # --- ± --- 0 PLACE # --- ± ---	MM ONLY	1:1	METRIC	SKRA JENDRANA 2011/02/14 MVANSLAMBROU 2011/02/14
	ANGULAR ± ---° DRAFT WHERE APPLICABLE MUST REMAIN WITHIN DIMENSIONS	MATERIAL NO. SEE BOM TABLE DATE	MX123 66/73/80CKT HRNS CONN ASSY molex	DOCUMENT NO. SD-34566-001 SHEET NO. 73 OF 85		
	THIS DRAWING CONTAINS INFORMATION THAT IS PROPRIETARY TO MOLEX INCORPORATED AND SHOULD NOT BE USED WITHOUT WRITTEN PERMISSION					

STATUS	GM PART #	MATERIAL #	PART/MATERIAL REVISION	WIRE DRESS OPTION	KEY OPTION Fp	COLOR (TPA) Fp	NUMBERS INDICATE CAVITIES OPEN FOR CIRCUITS Fp																																																																												
AVAILABLE	NOT APPLICABLE	34566-6723	G	0	H	ST.GRAY	<table border="1"> <tr><td>79</td><td></td><td></td><td>74</td><td>73</td><td></td><td></td><td></td><td>67</td><td>65</td><td>64</td><td>63</td><td>62</td><td>61</td></tr> <tr><td>59</td><td></td><td></td><td></td><td>53</td><td>52</td><td></td><td></td><td></td><td></td><td></td><td>44</td><td>43</td><td>42</td><td>41</td></tr> <tr><td></td><td>38</td><td></td><td></td><td></td><td>33</td><td></td><td></td><td></td><td>27</td><td></td><td>25</td><td></td><td></td><td></td></tr> <tr><td></td><td>18</td><td></td><td>15</td><td>14</td><td>13</td><td>12</td><td></td><td>10</td><td>9</td><td>8</td><td>7</td><td></td><td></td><td></td></tr> </table>	79			74	73				67	65	64	63	62	61	59				53	52						44	43	42	41		38				33				27		25					18		15	14	13	12		10	9	8	7																				
79			74	73				67	65	64	63	62	61																																																																						
59				53	52						44	43	42	41																																																																					
	38				33				27		25																																																																								
	18		15	14	13	12		10	9	8	7																																																																								
AVAILABLE	NOT APPLICABLE	34566-6733	G	0	G	BLUE	<table border="1"> <tr><td></td><td>78</td><td>77</td><td>75</td><td>74</td><td>72</td><td>70</td><td></td><td></td><td></td><td></td><td>64</td><td>63</td><td></td><td></td></tr> <tr><td>60</td><td>58</td><td>57</td><td>55</td><td>54</td><td>52</td><td>51</td><td>50</td><td>49</td><td></td><td>47</td><td></td><td>45</td><td></td><td></td></tr> <tr><td>40</td><td>39</td><td>38</td><td>37</td><td></td><td></td><td>33</td><td>32</td><td>31</td><td></td><td></td><td>27</td><td>26</td><td></td><td></td></tr> <tr><td>20</td><td>19</td><td>18</td><td>17</td><td></td><td></td><td></td><td></td><td>10</td><td>9</td><td>8</td><td>7</td><td>6</td><td>4</td><td>3</td><td>2</td><td>1</td></tr> </table>		78	77	75	74	72	70					64	63			60	58	57	55	54	52	51	50	49		47		45			40	39	38	37			33	32	31			27	26			20	19	18	17					10	9	8	7	6	4	3	2	1														
	78	77	75	74	72	70					64	63																																																																							
60	58	57	55	54	52	51	50	49		47		45																																																																							
40	39	38	37			33	32	31			27	26																																																																							
20	19	18	17					10	9	8	7	6	4	3	2	1																																																																			
AVAILABLE	NOT APPLICABLE	34566-6743	G	9	C	BLUE	<table border="1"> <tr><td></td><td>71</td><td>69</td><td>68</td><td>67</td><td>65</td><td>64</td><td>63</td><td>61</td><td>60</td><td></td><td></td><td>57</td><td></td><td></td><td></td><td></td></tr> <tr><td>52</td><td>51</td><td>50</td><td>48</td><td>46</td><td>45</td><td>44</td><td>43</td><td>41</td><td></td><td></td><td></td><td>37</td><td></td><td></td><td>34</td><td>33</td></tr> <tr><td></td><td>73</td><td></td><td></td><td></td><td></td><td></td><td>28</td><td>27</td><td>25</td><td></td><td></td><td></td><td></td><td></td><td></td><td></td></tr> <tr><td></td><td></td><td>16</td><td>15</td><td>14</td><td>13</td><td>12</td><td>11</td><td>10</td><td>9</td><td>8</td><td>7</td><td></td><td></td><td></td><td></td><td></td></tr> </table>		71	69	68	67	65	64	63	61	60			57					52	51	50	48	46	45	44	43	41				37			34	33		73						28	27	25										16	15	14	13	12	11	10	9	8	7													
	71	69	68	67	65	64	63	61	60			57																																																																							
52	51	50	48	46	45	44	43	41				37			34	33																																																																			
	73						28	27	25																																																																										
		16	15	14	13	12	11	10	9	8	7																																																																								
AVAILABLE	NOT APPLICABLE	34566-6753	G	9	A	BLACK	<table border="1"> <tr><td>72</td><td>71</td><td>70</td><td>69</td><td>68</td><td>66</td><td>65</td><td>64</td><td></td><td>61</td><td>60</td><td></td><td>57</td><td>56</td><td>54</td><td>53</td></tr> <tr><td>52</td><td>51</td><td>50</td><td>49</td><td>48</td><td>46</td><td>45</td><td>44</td><td>43</td><td>42</td><td>40</td><td>39</td><td>38</td><td>37</td><td>36</td><td>34</td><td>33</td></tr> <tr><td></td><td>73</td><td></td><td></td><td></td><td></td><td></td><td></td><td></td><td></td><td></td><td>23</td><td>22</td><td>21</td><td>20</td><td></td><td></td></tr> <tr><td></td><td></td><td></td><td></td><td>15</td><td>14</td><td>13</td><td>12</td><td></td><td></td><td>7</td><td>6</td><td>5</td><td>4</td><td></td><td>2</td><td></td></tr> </table>	72	71	70	69	68	66	65	64		61	60		57	56	54	53	52	51	50	49	48	46	45	44	43	42	40	39	38	37	36	34	33		73										23	22	21	20							15	14	13	12			7	6	5	4		2										
72	71	70	69	68	66	65	64		61	60		57	56	54	53																																																																				
52	51	50	49	48	46	45	44	43	42	40	39	38	37	36	34	33																																																																			
	73										23	22	21	20																																																																					
				15	14	13	12			7	6	5	4		2																																																																				
AVAILABLE	NOT APPLICABLE	34566-6763	G	9	B	ST.GRAY	<table border="1"> <tr><td>72</td><td></td><td></td><td>68</td><td></td><td></td><td></td><td></td><td>62</td><td>61</td><td></td><td></td><td></td><td></td><td></td><td>55</td><td></td></tr> <tr><td>52</td><td>50</td><td>49</td><td></td><td>46</td><td>45</td><td></td><td>43</td><td></td><td>40</td><td></td><td></td><td></td><td></td><td></td><td>34</td><td></td></tr> <tr><td></td><td>73</td><td></td><td></td><td></td><td>29</td><td></td><td></td><td></td><td></td><td></td><td></td><td>22</td><td>21</td><td>20</td><td>19</td><td>18</td></tr> <tr><td></td><td></td><td></td><td>16</td><td>14</td><td></td><td></td><td></td><td></td><td>8</td><td></td><td>6</td><td>5</td><td>4</td><td></td><td></td><td></td></tr> </table>	72			68					62	61						55		52	50	49		46	45		43		40						34			73				29							22	21	20	19	18				16	14					8		6	5	4											
72			68					62	61						55																																																																				
52	50	49		46	45		43		40						34																																																																				
	73				29							22	21	20	19	18																																																																			
			16	14					8		6	5	4																																																																						
AVAILABLE	NOT APPLICABLE	34566-6773	G	0	C	BLUE	<table border="1"> <tr><td>72</td><td>70</td><td></td><td>68</td><td>66</td><td></td><td>63</td><td>62</td><td></td><td></td><td>59</td><td>58</td><td>57</td><td></td><td></td><td></td><td>53</td></tr> <tr><td>52</td><td>51</td><td>49</td><td>48</td><td>47</td><td>46</td><td>44</td><td>42</td><td>40</td><td>39</td><td></td><td></td><td></td><td></td><td></td><td></td><td>34</td><td>33</td></tr> <tr><td></td><td>73</td><td></td><td>32</td><td>30</td><td></td><td></td><td>26</td><td>25</td><td></td><td></td><td>22</td><td>21</td><td>19</td><td>18</td><td>17</td><td></td><td></td></tr> <tr><td></td><td></td><td></td><td>15</td><td>14</td><td></td><td></td><td>10</td><td>9</td><td></td><td></td><td>6</td><td>5</td><td>4</td><td></td><td></td><td></td><td>1</td></tr> </table>	72	70		68	66		63	62			59	58	57				53	52	51	49	48	47	46	44	42	40	39							34	33		73		32	30			26	25			22	21	19	18	17						15	14			10	9			6	5	4				1					
72	70		68	66		63	62			59	58	57				53																																																																			
52	51	49	48	47	46	44	42	40	39							34	33																																																																		
	73		32	30			26	25			22	21	19	18	17																																																																				
			15	14			10	9			6	5	4				1																																																																		
AVAILABLE	NOT APPLICABLE	34566-6783	G	0	B	ST.GRAY	<table border="1"> <tr><td>72</td><td>70</td><td></td><td>68</td><td>66</td><td></td><td></td><td></td><td>60</td><td>59</td><td></td><td></td><td></td><td></td><td>55</td><td>54</td><td>53</td></tr> <tr><td>52</td><td>50</td><td></td><td>48</td><td>46</td><td></td><td>43</td><td></td><td>40</td><td>39</td><td></td><td></td><td></td><td></td><td>35</td><td>34</td><td>33</td></tr> <tr><td></td><td>73</td><td></td><td>32</td><td>31</td><td>30</td><td>29</td><td>28</td><td>27</td><td>26</td><td>25</td><td>24</td><td>23</td><td></td><td></td><td></td><td>17</td></tr> <tr><td></td><td></td><td></td><td>16</td><td></td><td></td><td></td><td></td><td>10</td><td>8</td><td>7</td><td></td><td></td><td></td><td></td><td></td><td>2</td><td>1</td></tr> </table>	72	70		68	66				60	59					55	54	53	52	50		48	46		43		40	39					35	34	33		73		32	31	30	29	28	27	26	25	24	23				17				16					10	8	7						2	1							
72	70		68	66				60	59					55	54	53																																																																			
52	50		48	46		43		40	39					35	34	33																																																																			
	73		32	31	30	29	28	27	26	25	24	23				17																																																																			
			16					10	8	7						2	1																																																																		
AVAILABLE	NOT APPLICABLE	34566-6793	G	0	B	ST.GRAY	<table border="1"> <tr><td>72</td><td>70</td><td></td><td>68</td><td>66</td><td>64</td><td>63</td><td></td><td>60</td><td>59</td><td></td><td></td><td></td><td></td><td>55</td><td>54</td><td>53</td></tr> <tr><td>52</td><td>50</td><td></td><td>48</td><td>46</td><td></td><td>43</td><td></td><td>40</td><td>39</td><td></td><td></td><td></td><td></td><td>35</td><td>34</td><td>33</td></tr> <tr><td></td><td>73</td><td></td><td>32</td><td>31</td><td>30</td><td>29</td><td>28</td><td>27</td><td>26</td><td>25</td><td>24</td><td>23</td><td></td><td>20</td><td></td><td>17</td></tr> <tr><td></td><td></td><td></td><td>16</td><td></td><td></td><td></td><td></td><td>10</td><td>8</td><td>7</td><td></td><td></td><td>5</td><td>4</td><td></td><td>2</td><td>1</td></tr> </table>	72	70		68	66	64	63		60	59					55	54	53	52	50		48	46		43		40	39					35	34	33		73		32	31	30	29	28	27	26	25	24	23		20		17				16					10	8	7			5	4		2	1							
72	70		68	66	64	63		60	59					55	54	53																																																																			
52	50		48	46		43		40	39					35	34	33																																																																			
	73		32	31	30	29	28	27	26	25	24	23		20		17																																																																			
			16					10	8	7			5	4		2	1																																																																		
AVAILABLE	NOT APPLICABLE	34566-6813	G	9	A	BLACK	<table border="1"> <tr><td></td><td>71</td><td>70</td><td>69</td><td>68</td><td>67</td><td>65</td><td>64</td><td>63</td><td>62</td><td>61</td><td>60</td><td></td><td>58</td><td>57</td><td>56</td><td>55</td><td>54</td><td>53</td></tr> <tr><td>52</td><td>51</td><td>50</td><td>49</td><td>48</td><td>47</td><td>45</td><td>44</td><td>43</td><td>42</td><td>41</td><td>40</td><td>39</td><td></td><td>37</td><td>36</td><td>34</td><td></td><td></td></tr> <tr><td></td><td>73</td><td></td><td></td><td>32</td><td>30</td><td>29</td><td>28</td><td>27</td><td>26</td><td>25</td><td>24</td><td></td><td></td><td>21</td><td></td><td>18</td><td></td><td></td></tr> <tr><td></td><td></td><td></td><td></td><td>16</td><td>15</td><td>14</td><td>13</td><td>12</td><td>11</td><td>10</td><td>9</td><td>8</td><td></td><td>5</td><td></td><td>3</td><td></td><td></td></tr> </table>		71	70	69	68	67	65	64	63	62	61	60		58	57	56	55	54	53	52	51	50	49	48	47	45	44	43	42	41	40	39		37	36	34				73			32	30	29	28	27	26	25	24			21		18							16	15	14	13	12	11	10	9	8		5		3		
	71	70	69	68	67	65	64	63	62	61	60		58	57	56	55	54	53																																																																	
52	51	50	49	48	47	45	44	43	42	41	40	39		37	36	34																																																																			
	73			32	30	29	28	27	26	25	24			21		18																																																																			
				16	15	14	13	12	11	10	9	8		5		3																																																																			

ENTER DESCRIPTION DEC NO. UAU2016-0232 DRAWN BY GJ34 CHKD: APPR:VKOSHY 2015/08/14	QUALITY SYMBOLS	GENERAL TOLERANCES (UNLESS SPECIFIED)	DIMENSION STYLE	SCALE	DESIGN UNITS	THIRD ANGLE PROJECTION	
	▽=0	mm INCH	MM ONLY	1:1	METRIC	☉	
	▽=0	4 PLACES # --- ± ---	DRAWN BY DATE			TITLE	
	▽=0	3 PLACES # --- ± ---	SKRA JENDRANA 2011/02/14			MX123	
▽=0	2 PLACES # --- ± ---	CHECKED BY DATE			66/73/80CKT		
	1 PLACE # --- ± ---	MVANS LAMBROU 2011/02/14			HRNS CONN ASSY		
	0 PLACE # --- ± ---	APPROVED BY DATE			molex		
	ANGULAR ± ---°	MATERIAL NO.	SEE BOM TABLE		DOCUMENT NO.	SHEET NO.	
	DRAFT WHERE APPLICABLE MUST REMAIN WITHIN DIMENSIONS	SD-34566-001			SD-34566-001	74 OF 85	
		THIS DRAWING CONTAINS INFORMATION THAT IS PROPRIETARY TO MOLEX INCORPORATED AND SHOULD NOT BE USED WITHOUT WRITTEN PERMISSION					

STATUS	GM PART #	MATERIAL #	PART/MATERIAL REVISION	WIRE DRESS OPTION	KEY OPTION F _P	COLOR (TPA) F _P	NUMBERS INDICATE CAVITIES OPEN FOR CIRCUITS F _P																																																																																
AVAILABLE	NOT APPLICABLE	34566-6823	G	9	C	BLUE	<table border="1"> <tr><td>72</td><td>70</td><td>68</td><td>67</td><td>66</td><td></td><td>63</td><td>62</td><td></td><td>59</td><td></td><td>57</td><td></td><td></td><td>53</td></tr> <tr><td>52</td><td>51</td><td>49</td><td>48</td><td>47</td><td>46</td><td>44</td><td></td><td>41</td><td>40</td><td>39</td><td>37</td><td>36</td><td>35</td><td>34</td><td>33</td></tr> <tr><td colspan="2">73</td><td></td><td>32</td><td>30</td><td></td><td></td><td>27</td><td>26</td><td>25</td><td>24</td><td>22</td><td>21</td><td>20</td><td></td><td></td></tr> <tr><td></td><td></td><td></td><td>15</td><td>14</td><td>13</td><td></td><td></td><td>10</td><td>9</td><td>8</td><td>6</td><td>5</td><td>4</td><td></td><td>2</td></tr> </table>	72	70	68	67	66		63	62		59		57			53	52	51	49	48	47	46	44		41	40	39	37	36	35	34	33	73			32	30			27	26	25	24	22	21	20						15	14	13			10	9	8	6	5	4		2																	
72	70	68	67	66		63	62		59		57			53																																																																									
52	51	49	48	47	46	44		41	40	39	37	36	35	34	33																																																																								
73			32	30			27	26	25	24	22	21	20																																																																										
			15	14	13			10	9	8	6	5	4		2																																																																								
AVAILABLE	NOT APPLICABLE	34566-6833	G	0	A	BLACK	<table border="1"> <tr><td></td><td>70</td><td>69</td><td></td><td></td><td></td><td>63</td><td></td><td></td><td>60</td><td>59</td><td>58</td><td>57</td><td>56</td><td>55</td><td>54</td><td>53</td></tr> <tr><td>52</td><td>51</td><td>49</td><td>48</td><td>47</td><td></td><td>44</td><td>43</td><td>42</td><td>41</td><td>40</td><td></td><td>37</td><td>36</td><td></td><td>34</td><td>33</td></tr> <tr><td colspan="2">73</td><td></td><td>32</td><td></td><td></td><td></td><td>28</td><td>26</td><td></td><td></td><td></td><td></td><td></td><td>19</td><td>18</td><td></td></tr> <tr><td></td><td></td><td></td><td>16</td><td>15</td><td></td><td></td><td>12</td><td>10</td><td></td><td></td><td></td><td></td><td></td><td>3</td><td></td><td></td></tr> </table>		70	69				63			60	59	58	57	56	55	54	53	52	51	49	48	47		44	43	42	41	40		37	36		34	33	73			32				28	26						19	18					16	15			12	10						3														
	70	69				63			60	59	58	57	56	55	54	53																																																																							
52	51	49	48	47		44	43	42	41	40		37	36		34	33																																																																							
73			32				28	26						19	18																																																																								
			16	15			12	10						3																																																																									
AVAILABLE	NOT APPLICABLE	34566-6843	G	0	A	BLACK	<table border="1"> <tr><td>72</td><td>71</td><td>70</td><td>69</td><td>68</td><td></td><td>66</td><td>65</td><td>64</td><td>63</td><td></td><td>61</td><td>60</td><td></td><td>57</td><td>56</td><td>54</td><td>53</td></tr> <tr><td>52</td><td>51</td><td>50</td><td>49</td><td>48</td><td></td><td>46</td><td>45</td><td>44</td><td>43</td><td></td><td></td><td>40</td><td>39</td><td>38</td><td>37</td><td>36</td><td>34</td><td>33</td></tr> <tr><td colspan="2">73</td><td></td><td>32</td><td>31</td><td>30</td><td>29</td><td>28</td><td></td><td>26</td><td>25</td><td></td><td>23</td><td>22</td><td>21</td><td>20</td><td></td><td>17</td><td></td></tr> <tr><td></td><td></td><td></td><td>15</td><td>14</td><td>13</td><td>12</td><td></td><td></td><td>9</td><td>7</td><td>6</td><td>5</td><td>4</td><td></td><td></td><td>2</td><td></td><td></td></tr> </table>	72	71	70	69	68		66	65	64	63		61	60		57	56	54	53	52	51	50	49	48		46	45	44	43			40	39	38	37	36	34	33	73			32	31	30	29	28		26	25		23	22	21	20		17					15	14	13	12			9	7	6	5	4			2							
72	71	70	69	68		66	65	64	63		61	60		57	56	54	53																																																																						
52	51	50	49	48		46	45	44	43			40	39	38	37	36	34	33																																																																					
73			32	31	30	29	28		26	25		23	22	21	20		17																																																																						
			15	14	13	12			9	7	6	5	4			2																																																																							
AVAILABLE	NOT APPLICABLE	34566-6853	G	0	C	BLUE	<table border="1"> <tr><td></td><td></td><td>69</td><td></td><td>67</td><td>66</td><td></td><td>64</td><td></td><td>62</td><td>61</td><td>60</td><td></td><td></td><td>57</td><td></td><td>55</td><td>54</td><td></td></tr> <tr><td>52</td><td>51</td><td>50</td><td>49</td><td>48</td><td></td><td>46</td><td>45</td><td>44</td><td></td><td>42</td><td>41</td><td></td><td></td><td>37</td><td></td><td>35</td><td>34</td><td>33</td></tr> <tr><td colspan="2">73</td><td></td><td>32</td><td></td><td></td><td></td><td>28</td><td>27</td><td>26</td><td>25</td><td></td><td></td><td></td><td></td><td></td><td>19</td><td>18</td><td>17</td></tr> <tr><td></td><td></td><td></td><td>16</td><td>15</td><td>14</td><td>13</td><td>12</td><td>11</td><td>10</td><td>9</td><td>8</td><td>7</td><td></td><td></td><td></td><td></td><td></td><td></td></tr> </table>			69		67	66		64		62	61	60			57		55	54		52	51	50	49	48		46	45	44		42	41			37		35	34	33	73			32				28	27	26	25						19	18	17				16	15	14	13	12	11	10	9	8	7										
		69		67	66		64		62	61	60			57		55	54																																																																						
52	51	50	49	48		46	45	44		42	41			37		35	34	33																																																																					
73			32				28	27	26	25						19	18	17																																																																					
			16	15	14	13	12	11	10	9	8	7																																																																											
AVAILABLE	NOT APPLICABLE	34566-6863	G	0	A	BLACK	<table border="1"> <tr><td>72</td><td>71</td><td>70</td><td>69</td><td>68</td><td></td><td>66</td><td>65</td><td>64</td><td>63</td><td></td><td>61</td><td>60</td><td></td><td>57</td><td>56</td><td>54</td><td>53</td></tr> <tr><td>52</td><td>51</td><td>50</td><td>49</td><td>48</td><td></td><td>46</td><td>45</td><td>44</td><td>43</td><td>42</td><td></td><td>40</td><td>39</td><td>38</td><td>37</td><td>36</td><td>34</td><td>33</td></tr> <tr><td colspan="2">73</td><td></td><td>32</td><td>31</td><td>30</td><td>29</td><td>28</td><td></td><td>26</td><td>25</td><td></td><td>23</td><td>22</td><td>21</td><td>20</td><td></td><td></td><td></td></tr> <tr><td></td><td></td><td></td><td>15</td><td>14</td><td>13</td><td>12</td><td></td><td></td><td>9</td><td>7</td><td>6</td><td>5</td><td>4</td><td></td><td></td><td>2</td><td></td><td></td></tr> </table>	72	71	70	69	68		66	65	64	63		61	60		57	56	54	53	52	51	50	49	48		46	45	44	43	42		40	39	38	37	36	34	33	73			32	31	30	29	28		26	25		23	22	21	20							15	14	13	12			9	7	6	5	4			2							
72	71	70	69	68		66	65	64	63		61	60		57	56	54	53																																																																						
52	51	50	49	48		46	45	44	43	42		40	39	38	37	36	34	33																																																																					
73			32	31	30	29	28		26	25		23	22	21	20																																																																								
			15	14	13	12			9	7	6	5	4			2																																																																							
AVAILABLE	NOT APPLICABLE	34566-6873	G	9	B	ST.GRAY	<table border="1"> <tr><td>72</td><td></td><td></td><td>68</td><td>67</td><td></td><td></td><td>63</td><td>62</td><td>61</td><td>60</td><td>59</td><td></td><td></td><td></td><td>55</td><td>53</td></tr> <tr><td>52</td><td></td><td></td><td>48</td><td>47</td><td>46</td><td></td><td>44</td><td>43</td><td></td><td>41</td><td>40</td><td></td><td>38</td><td>37</td><td>36</td><td>35</td><td></td><td></td></tr> <tr><td colspan="2">73</td><td></td><td></td><td>30</td><td></td><td></td><td>27</td><td></td><td></td><td></td><td></td><td></td><td></td><td></td><td>20</td><td>19</td><td>18</td><td>17</td></tr> <tr><td></td><td></td><td></td><td>16</td><td>15</td><td>14</td><td></td><td>11</td><td></td><td></td><td>8</td><td></td><td></td><td></td><td></td><td>4</td><td></td><td></td><td>1</td></tr> </table>	72			68	67			63	62	61	60	59				55	53	52			48	47	46		44	43		41	40		38	37	36	35			73				30			27								20	19	18	17				16	15	14		11			8					4			1						
72			68	67			63	62	61	60	59				55	53																																																																							
52			48	47	46		44	43		41	40		38	37	36	35																																																																							
73				30			27								20	19	18	17																																																																					
			16	15	14		11			8					4			1																																																																					
AVAILABLE	NOT APPLICABLE	34566-6883	G	9	A	BLACK	<table border="1"> <tr><td>72</td><td></td><td>70</td><td></td><td>67</td><td></td><td></td><td>63</td><td></td><td></td><td>60</td><td>59</td><td>58</td><td>57</td><td>56</td><td>55</td><td></td><td></td><td></td></tr> <tr><td>52</td><td>51</td><td></td><td></td><td>48</td><td>47</td><td>46</td><td></td><td>43</td><td>42</td><td></td><td>40</td><td>39</td><td>38</td><td>37</td><td>36</td><td>35</td><td></td><td></td></tr> <tr><td colspan="2">73</td><td></td><td></td><td></td><td></td><td></td><td></td><td>28</td><td>27</td><td></td><td></td><td></td><td>22</td><td>21</td><td></td><td></td><td>18</td><td>17</td></tr> <tr><td></td><td></td><td></td><td></td><td></td><td></td><td></td><td>12</td><td>11</td><td></td><td>9</td><td>7</td><td></td><td>5</td><td></td><td></td><td></td><td>2</td><td>1</td></tr> </table>	72		70		67			63			60	59	58	57	56	55				52	51			48	47	46		43	42		40	39	38	37	36	35			73								28	27				22	21			18	17								12	11		9	7		5				2	1				
72		70		67			63			60	59	58	57	56	55																																																																								
52	51			48	47	46		43	42		40	39	38	37	36	35																																																																							
73								28	27				22	21			18	17																																																																					
							12	11		9	7		5				2	1																																																																					
AVAILABLE	NOT APPLICABLE	34566-6893	G	0	B	ST.GRAY	<table border="1"> <tr><td>72</td><td>71</td><td>70</td><td>69</td><td>68</td><td>67</td><td>66</td><td>65</td><td>64</td><td>63</td><td>62</td><td>61</td><td>60</td><td>59</td><td></td><td>57</td><td>56</td><td>55</td><td></td><td></td></tr> <tr><td>52</td><td>51</td><td>50</td><td>49</td><td>48</td><td>47</td><td>46</td><td>45</td><td>44</td><td>43</td><td></td><td>41</td><td>40</td><td>39</td><td>38</td><td>37</td><td>36</td><td>35</td><td>34</td><td>33</td></tr> <tr><td colspan="2">73</td><td></td><td>32</td><td>31</td><td>30</td><td>29</td><td>28</td><td></td><td>26</td><td></td><td>24</td><td>23</td><td>22</td><td>21</td><td>20</td><td>19</td><td>18</td><td>17</td><td></td></tr> <tr><td></td><td></td><td></td><td>16</td><td>15</td><td>14</td><td>13</td><td>12</td><td>11</td><td></td><td>9</td><td>8</td><td>7</td><td>6</td><td>5</td><td>4</td><td>3</td><td>2</td><td>1</td><td></td></tr> </table>	72	71	70	69	68	67	66	65	64	63	62	61	60	59		57	56	55			52	51	50	49	48	47	46	45	44	43		41	40	39	38	37	36	35	34	33	73			32	31	30	29	28		26		24	23	22	21	20	19	18	17					16	15	14	13	12	11		9	8	7	6	5	4	3	2	1	
72	71	70	69	68	67	66	65	64	63	62	61	60	59		57	56	55																																																																						
52	51	50	49	48	47	46	45	44	43		41	40	39	38	37	36	35	34	33																																																																				
73			32	31	30	29	28		26		24	23	22	21	20	19	18	17																																																																					
			16	15	14	13	12	11		9	8	7	6	5	4	3	2	1																																																																					
AVAILABLE	NOT APPLICABLE	34566-6913	G	9	A	BLACK	<table border="1"> <tr><td>72</td><td>71</td><td>70</td><td>69</td><td>68</td><td>67</td><td>66</td><td>65</td><td>64</td><td>63</td><td></td><td>60</td><td>59</td><td>58</td><td>57</td><td>56</td><td>55</td><td>54</td><td></td><td></td></tr> <tr><td>52</td><td>51</td><td>50</td><td>49</td><td>48</td><td>47</td><td>46</td><td>45</td><td>44</td><td>43</td><td>42</td><td></td><td>40</td><td>39</td><td>38</td><td>37</td><td>36</td><td>35</td><td>34</td><td></td></tr> <tr><td colspan="2">73</td><td></td><td>32</td><td>31</td><td>30</td><td>29</td><td>28</td><td>27</td><td>26</td><td>25</td><td></td><td>23</td><td>22</td><td>21</td><td>20</td><td></td><td>18</td><td>17</td><td></td></tr> <tr><td></td><td></td><td></td><td>16</td><td>15</td><td>14</td><td>13</td><td>12</td><td>11</td><td></td><td>9</td><td>7</td><td>6</td><td>5</td><td>4</td><td></td><td></td><td>2</td><td>1</td><td></td></tr> </table>	72	71	70	69	68	67	66	65	64	63		60	59	58	57	56	55	54			52	51	50	49	48	47	46	45	44	43	42		40	39	38	37	36	35	34		73			32	31	30	29	28	27	26	25		23	22	21	20		18	17					16	15	14	13	12	11		9	7	6	5	4			2	1	
72	71	70	69	68	67	66	65	64	63		60	59	58	57	56	55	54																																																																						
52	51	50	49	48	47	46	45	44	43	42		40	39	38	37	36	35	34																																																																					
73			32	31	30	29	28	27	26	25		23	22	21	20		18	17																																																																					
			16	15	14	13	12	11		9	7	6	5	4			2	1																																																																					

ENTER DESCRIPTION DEC NO: UAU2016-0232 DRAWN BY: CHKD: G34 2015/08/14 APPR: VKOSH 2015/08/14	QUALITY SYMBOLS ∇=0 ∇=0 ∇=0	GENERAL TOLERANCES (UNLESS SPECIFIED) <table border="1"> <tr><td></td><td>mm</td><td>INCH</td></tr> <tr><td>4 PLACES</td><td>±---</td><td>±---</td></tr> <tr><td>3 PLACES</td><td>±---</td><td>±---</td></tr> <tr><td>2 PLACES</td><td>±---</td><td>±---</td></tr> <tr><td>1 PLACE</td><td>±---</td><td>±---</td></tr> <tr><td>0 PLACE</td><td>±---</td><td>±---</td></tr> </table>		mm	INCH	4 PLACES	±---	±---	3 PLACES	±---	±---	2 PLACES	±---	±---	1 PLACE	±---	±---	0 PLACE	±---	±---	DIMENSION STYLE MM ONLY	SCALE 1:1	DESIGN UNITS METRIC	THIRD ANGLE PROJECTION
		mm	INCH																					
	4 PLACES	±---	±---																					
	3 PLACES	±---	±---																					
2 PLACES	±---	±---																						
1 PLACE	±---	±---																						
0 PLACE	±---	±---																						
DRAWN BY: SKRA JENDRANA 2011/02/14 CHECKED BY: MVANSLAMBROU 2011/02/14 APPROVED BY:	DATE:	DATE:	DATE:	MATERIAL NO.	DOCUMENT NO.	SHEET NO.																		
ANGULAR ±--- DRAFT WHERE APPLICABLE MUST REMAIN WITHIN DIMENSIONS	SEE BOM TABLE	THIS DRAWING CONTAINS INFORMATION THAT IS PROPRIETARY TO MOLEX INCORPORATED AND SHOULD NOT BE USED WITHOUT WRITTEN PERMISSION	MX123 66/73/80CKT HRNS CONN ASSY molex SD-34566-001	75 OF 85																				

STATUS	GM PART #	MATERIAL #	PART/MATERIAL REVISION	WIRE DRESS OPTION	KEY OPTION Fp	COLOR (TPA) Fp	NUMBERS INDICATE CAVITIES OPEN FOR CIRCUITS Fp																																																																									
AVAILABLE	NOT APPLICABLE	34566-6923	G	9	C	BLUE	<table border="1"> <tr><td>72</td><td>71</td><td>70</td><td>69</td><td>67</td><td>66</td><td>65</td><td>64</td><td>61</td><td>60</td><td>58</td><td>57</td><td>56</td><td>54</td><td></td></tr> <tr><td>52</td><td>51</td><td>50</td><td>49</td><td>48</td><td>47</td><td>46</td><td>45</td><td>44</td><td>41</td><td>39</td><td>38</td><td>37</td><td>34</td><td>33</td></tr> <tr><td colspan="4">73</td><td>32</td><td>31</td><td>30</td><td>29</td><td>28</td><td>27</td><td>26</td><td>25</td><td>24</td><td>23</td><td>22</td><td>21</td><td>18</td><td>17</td></tr> <tr><td colspan="4"></td><td>16</td><td>15</td><td>14</td><td>13</td><td>12</td><td>11</td><td>10</td><td>9</td><td>8</td><td>7</td><td>6</td><td>5</td><td></td><td></td></tr> </table>	72	71	70	69	67	66	65	64	61	60	58	57	56	54		52	51	50	49	48	47	46	45	44	41	39	38	37	34	33	73				32	31	30	29	28	27	26	25	24	23	22	21	18	17					16	15	14	13	12	11	10	9	8	7	6	5									
72	71	70	69	67	66	65	64	61	60	58	57	56	54																																																																			
52	51	50	49	48	47	46	45	44	41	39	38	37	34	33																																																																		
73				32	31	30	29	28	27	26	25	24	23	22	21	18	17																																																															
				16	15	14	13	12	11	10	9	8	7	6	5																																																																	
AVAILABLE	NOT APPLICABLE	34566-6933	G	9	B	ST.GRAY	<table border="1"> <tr><td>72</td><td></td><td></td><td></td><td>68</td><td>67</td><td></td><td></td><td>63</td><td>62</td><td>61</td><td>60</td><td>59</td><td></td><td></td><td>55</td><td>53</td></tr> <tr><td>52</td><td></td><td></td><td></td><td>48</td><td>47</td><td>46</td><td></td><td>44</td><td>43</td><td>41</td><td>40</td><td></td><td>38</td><td>37</td><td>36</td><td>35</td></tr> <tr><td colspan="4">73</td><td colspan="2">30</td><td></td><td></td><td>27</td><td></td><td></td><td></td><td></td><td>22</td><td>21</td><td>20</td><td>19</td><td>18</td><td>17</td></tr> <tr><td colspan="4"></td><td>16</td><td>15</td><td>14</td><td></td><td>11</td><td></td><td></td><td></td><td>8</td><td>7</td><td>6</td><td>4</td><td></td><td></td><td>1</td></tr> </table>	72				68	67			63	62	61	60	59			55	53	52				48	47	46		44	43	41	40		38	37	36	35	73				30				27					22	21	20	19	18	17					16	15	14		11				8	7	6	4			1	
72				68	67			63	62	61	60	59			55	53																																																																
52				48	47	46		44	43	41	40		38	37	36	35																																																																
73				30				27					22	21	20	19	18	17																																																														
				16	15	14		11				8	7	6	4			1																																																														
AVAILABLE	NOT APPLICABLE	34566-6943	G	9	A	BLACK	<table border="1"> <tr><td>72</td><td>71</td><td>70</td><td>69</td><td>68</td><td>66</td><td>65</td><td>64</td><td>63</td><td>61</td><td>60</td><td></td><td></td><td>57</td><td>56</td><td>54</td><td>53</td></tr> <tr><td>52</td><td>51</td><td>50</td><td>49</td><td>48</td><td>46</td><td>45</td><td>44</td><td>43</td><td>42</td><td>41</td><td>40</td><td>39</td><td>38</td><td>37</td><td>36</td><td>34</td><td>33</td></tr> <tr><td colspan="4">73</td><td>32</td><td>31</td><td>30</td><td>29</td><td>28</td><td></td><td></td><td></td><td>23</td><td>22</td><td>21</td><td></td><td></td><td></td><td></td></tr> <tr><td colspan="4"></td><td>15</td><td>14</td><td>13</td><td>12</td><td></td><td></td><td></td><td></td><td>7</td><td>6</td><td>5</td><td></td><td></td><td>2</td><td>1</td></tr> </table>	72	71	70	69	68	66	65	64	63	61	60			57	56	54	53	52	51	50	49	48	46	45	44	43	42	41	40	39	38	37	36	34	33	73				32	31	30	29	28				23	22	21									15	14	13	12					7	6	5			2	1
72	71	70	69	68	66	65	64	63	61	60			57	56	54	53																																																																
52	51	50	49	48	46	45	44	43	42	41	40	39	38	37	36	34	33																																																															
73				32	31	30	29	28				23	22	21																																																																		
				15	14	13	12					7	6	5			2	1																																																														
AVAILABLE	NOT APPLICABLE	34566-6953	G	0	A	BLACK	<table border="1"> <tr><td>72</td><td>71</td><td>70</td><td>69</td><td></td><td>66</td><td>64</td><td>63</td><td>61</td><td>60</td><td></td><td></td><td></td><td>57</td><td>56</td><td>54</td><td>53</td></tr> <tr><td>52</td><td>51</td><td>50</td><td>49</td><td></td><td>46</td><td>45</td><td>44</td><td>43</td><td>40</td><td>39</td><td>38</td><td>37</td><td>36</td><td>34</td><td>33</td><td></td></tr> <tr><td colspan="4">73</td><td>32</td><td>31</td><td>30</td><td>29</td><td>28</td><td>26</td><td>25</td><td></td><td></td><td>23</td><td>22</td><td>21</td><td>20</td><td></td></tr> <tr><td colspan="4"></td><td>16</td><td>15</td><td>14</td><td>13</td><td>12</td><td></td><td>9</td><td>7</td><td>6</td><td>5</td><td>4</td><td></td><td>2</td><td>1</td></tr> </table>	72	71	70	69		66	64	63	61	60				57	56	54	53	52	51	50	49		46	45	44	43	40	39	38	37	36	34	33		73				32	31	30	29	28	26	25			23	22	21	20						16	15	14	13	12		9	7	6	5	4		2	1			
72	71	70	69		66	64	63	61	60				57	56	54	53																																																																
52	51	50	49		46	45	44	43	40	39	38	37	36	34	33																																																																	
73				32	31	30	29	28	26	25			23	22	21	20																																																																
				16	15	14	13	12		9	7	6	5	4		2	1																																																															
AVAILABLE	NOT APPLICABLE	34566-6963	G	0	B	ST.GRAY	<table border="1"> <tr><td>72</td><td>70</td><td>68</td><td>67</td><td></td><td></td><td></td><td></td><td>62</td><td>61</td><td></td><td></td><td></td><td></td><td></td><td>55</td><td></td></tr> <tr><td>52</td><td></td><td>48</td><td>47</td><td>46</td><td></td><td></td><td></td><td>43</td><td></td><td>40</td><td></td><td></td><td></td><td></td><td>20</td><td>19</td><td>18</td></tr> <tr><td colspan="4">73</td><td colspan="2">30</td><td></td><td></td><td></td><td></td><td></td><td></td><td></td><td></td><td></td><td>4</td><td></td><td>2</td></tr> <tr><td colspan="4"></td><td>16</td><td>15</td><td>14</td><td></td><td></td><td></td><td></td><td>8</td><td></td><td></td><td></td><td></td><td></td><td></td></tr> </table>	72	70	68	67					62	61						55		52		48	47	46				43		40					20	19	18	73				30											4		2					16	15	14					8								
72	70	68	67					62	61						55																																																																	
52		48	47	46				43		40					20	19	18																																																															
73				30											4		2																																																															
				16	15	14					8																																																																					
AVAILABLE	NOT APPLICABLE	34566-6973	G	0	C	BLUE	<table border="1"> <tr><td>71</td><td>70</td><td>69</td><td>67</td><td>65</td><td>64</td><td>62</td><td>61</td><td>60</td><td></td><td></td><td></td><td>57</td><td>55</td><td>54</td><td></td></tr> <tr><td>52</td><td>51</td><td>50</td><td>49</td><td>48</td><td>47</td><td>46</td><td>45</td><td>44</td><td>42</td><td>41</td><td></td><td></td><td>37</td><td>35</td><td>34</td><td>33</td></tr> <tr><td colspan="4">73</td><td>32</td><td></td><td></td><td>28</td><td>27</td><td>26</td><td>25</td><td></td><td></td><td></td><td></td><td>19</td><td>18</td><td>17</td></tr> <tr><td colspan="4"></td><td>16</td><td>15</td><td>14</td><td>13</td><td>12</td><td>11</td><td>10</td><td>9</td><td>8</td><td>7</td><td></td><td></td><td></td><td></td></tr> </table>	71	70	69	67	65	64	62	61	60				57	55	54		52	51	50	49	48	47	46	45	44	42	41			37	35	34	33	73				32			28	27	26	25					19	18	17					16	15	14	13	12	11	10	9	8	7								
71	70	69	67	65	64	62	61	60				57	55	54																																																																		
52	51	50	49	48	47	46	45	44	42	41			37	35	34	33																																																																
73				32			28	27	26	25					19	18	17																																																															
				16	15	14	13	12	11	10	9	8	7																																																																			
AVAILABLE	NOT APPLICABLE	34566-6983	G	0	C	BLUE	<table border="1"> <tr><td>71</td><td>69</td><td>67</td><td>65</td><td>64</td><td>62</td><td>60</td><td></td><td></td><td></td><td></td><td></td><td>57</td><td></td><td>54</td><td></td></tr> <tr><td>52</td><td>51</td><td>50</td><td>48</td><td>47</td><td>46</td><td>45</td><td>44</td><td>42</td><td></td><td></td><td></td><td>37</td><td></td><td>34</td><td>33</td></tr> <tr><td colspan="4">73</td><td>32</td><td></td><td></td><td>28</td><td>27</td><td>26</td><td></td><td></td><td></td><td></td><td></td><td>18</td><td></td></tr> <tr><td colspan="4"></td><td>16</td><td>15</td><td>14</td><td>13</td><td>12</td><td>11</td><td>10</td><td>9</td><td>8</td><td>7</td><td></td><td></td><td></td><td></td></tr> </table>	71	69	67	65	64	62	60						57		54		52	51	50	48	47	46	45	44	42				37		34	33	73				32			28	27	26						18						16	15	14	13	12	11	10	9	8	7										
71	69	67	65	64	62	60						57		54																																																																		
52	51	50	48	47	46	45	44	42				37		34	33																																																																	
73				32			28	27	26						18																																																																	
				16	15	14	13	12	11	10	9	8	7																																																																			
AVAILABLE	NOT APPLICABLE	34566-6993	G	0	G	BLUE	<table border="1"> <tr><td></td><td></td><td>78</td><td>77</td><td>76</td><td></td><td></td><td></td><td></td><td></td><td></td><td></td><td>67</td><td>66</td><td>65</td><td></td><td></td></tr> <tr><td>40</td><td>39</td><td>38</td><td>37</td><td>36</td><td>35</td><td>34</td><td>33</td><td>32</td><td></td><td></td><td></td><td>29</td><td>28</td><td></td><td></td><td>21</td></tr> <tr><td>20</td><td>19</td><td>18</td><td>17</td><td>16</td><td>15</td><td>14</td><td>13</td><td>12</td><td></td><td></td><td></td><td></td><td></td><td></td><td>3</td><td>1</td></tr> </table>			78	77	76								67	66	65			40	39	38	37	36	35	34	33	32				29	28			21	20	19	18	17	16	15	14	13	12							3	1																						
		78	77	76								67	66	65																																																																		
40	39	38	37	36	35	34	33	32				29	28			21																																																																
20	19	18	17	16	15	14	13	12							3	1																																																																
AVAILABLE	NOT APPLICABLE	34566-7013	G	9	A	BLACK	<table border="1"> <tr><td>71</td><td>70</td><td>69</td><td></td><td></td><td>64</td><td>63</td><td>62</td><td>61</td><td>60</td><td>59</td><td>58</td><td>57</td><td>56</td><td>55</td><td>54</td><td>53</td></tr> <tr><td>52</td><td>51</td><td>50</td><td>49</td><td></td><td>45</td><td>44</td><td>43</td><td>42</td><td>41</td><td>39</td><td></td><td>37</td><td>36</td><td></td><td>34</td><td></td></tr> <tr><td colspan="4">73</td><td>32</td><td></td><td>29</td><td>28</td><td>27</td><td>26</td><td></td><td></td><td></td><td></td><td></td><td>19</td><td>18</td></tr> <tr><td colspan="4"></td><td>16</td><td>15</td><td>14</td><td>13</td><td>12</td><td>11</td><td>10</td><td></td><td></td><td></td><td></td><td>3</td><td></td><td></td></tr> </table>	71	70	69			64	63	62	61	60	59	58	57	56	55	54	53	52	51	50	49		45	44	43	42	41	39		37	36		34		73				32		29	28	27	26						19	18					16	15	14	13	12	11	10					3						
71	70	69			64	63	62	61	60	59	58	57	56	55	54	53																																																																
52	51	50	49		45	44	43	42	41	39		37	36		34																																																																	
73				32		29	28	27	26						19	18																																																																
				16	15	14	13	12	11	10					3																																																																	

ENTER DESCRIPTION DEC NO. JAU2016-0232 DRAWN BY G34 CHKD: APPR:VKOSH 2015/08/14	QUALITY SYMBOLS	GENERAL TOLERANCES (UNLESS SPECIFIED)	DIMENSION STYLE	SCALE	DESIGN UNITS	THIRD ANGLE PROJECTION
	▽=0	mm INCH	MM ONLY	1:1	METRIC	
	▽=0	4 PLACES ± --- ± ---	DRAWN BY SKRA JENDRANA	DATE 2011/02/14	TITLE	MX123
	▽=0	3 PLACES ± --- ± ---	CHECKED BY	DATE		66/73/80CKT
	2 PLACES ± --- ± ---	1 PLACE ± --- ± ---	APPROVED BY	DATE		HRNS CONN ASSY
	0 PLACE ± --- ± ---	ANGULAR ± ---	MATERIAL NO.	DOCUMENT NO.		molex
	DRAFT WHERE APPLICABLE MUST REMAIN WITHIN DIMENSIONS	SEE BOM TABLE				SD-34566-001
						SHEET NO. 76 OF 85

STATUS	GM PART #	MATERIAL #	PART / MATERIAL REVISION	WIRE DRESS OPTION	KEY OPTION Fp	COLOR (TPA) Fp	NUMBERS INDICATE CAVITIES OPEN FOR CIRCUITS Fp																																																																												
AVAILABLE	NOT APPLICABLE	34566-7023	G	0	A	BLACK	<table border="1"> <tr><td>72</td><td>71</td><td>70</td><td>69</td><td>68</td><td>66</td><td>65</td><td>64</td><td></td><td>61</td><td>60</td><td></td><td>57</td><td>56</td><td>54</td><td>53</td></tr> <tr><td>52</td><td>51</td><td>50</td><td>49</td><td>48</td><td>46</td><td>45</td><td>44</td><td>43</td><td>40</td><td>39</td><td>38</td><td>37</td><td>36</td><td>34</td><td>33</td></tr> <tr><td colspan="2">73</td><td></td><td></td><td></td><td>31</td><td>30</td><td>29</td><td>28</td><td>26</td><td>25</td><td>23</td><td>22</td><td>21</td><td>20</td><td></td></tr> <tr><td></td><td></td><td></td><td></td><td></td><td>15</td><td>14</td><td>13</td><td>12</td><td></td><td>9</td><td>7</td><td>6</td><td>5</td><td>4</td><td>2</td></tr> </table>	72	71	70	69	68	66	65	64		61	60		57	56	54	53	52	51	50	49	48	46	45	44	43	40	39	38	37	36	34	33	73					31	30	29	28	26	25	23	22	21	20							15	14	13	12		9	7	6	5	4	2												
72	71	70	69	68	66	65	64		61	60		57	56	54	53																																																																				
52	51	50	49	48	46	45	44	43	40	39	38	37	36	34	33																																																																				
73					31	30	29	28	26	25	23	22	21	20																																																																					
					15	14	13	12		9	7	6	5	4	2																																																																				
AVAILABLE	NOT APPLICABLE	34566-7033	G	0	A	BLACK	<table border="1"> <tr><td></td><td>70</td><td>69</td><td></td><td></td><td>65</td><td>63</td><td>62</td><td>61</td><td>60</td><td></td><td>58</td><td>57</td><td>56</td><td>55</td><td>54</td><td>53</td></tr> <tr><td>52</td><td>51</td><td>49</td><td></td><td></td><td>44</td><td>43</td><td>42</td><td>41</td><td></td><td></td><td></td><td>37</td><td>36</td><td>34</td><td></td><td></td></tr> <tr><td colspan="2">73</td><td></td><td>32</td><td></td><td>29</td><td>28</td><td>27</td><td>26</td><td></td><td></td><td></td><td>21</td><td>19</td><td>18</td><td></td><td></td></tr> <tr><td></td><td></td><td></td><td>16</td><td>15</td><td>13</td><td>12</td><td>11</td><td>10</td><td></td><td>8</td><td></td><td></td><td>5</td><td>3</td><td></td><td></td></tr> </table>		70	69			65	63	62	61	60		58	57	56	55	54	53	52	51	49			44	43	42	41				37	36	34			73			32		29	28	27	26				21	19	18						16	15	13	12	11	10		8			5	3										
	70	69			65	63	62	61	60		58	57	56	55	54	53																																																																			
52	51	49			44	43	42	41				37	36	34																																																																					
73			32		29	28	27	26				21	19	18																																																																					
			16	15	13	12	11	10		8			5	3																																																																					
AVAILABLE	NOT APPLICABLE	34566-7043	G	0	B	ST.GRAY	<table border="1"> <tr><td>72</td><td></td><td></td><td>68</td><td>67</td><td></td><td></td><td>63</td><td>62</td><td>61</td><td>60</td><td>59</td><td></td><td></td><td>55</td><td></td><td></td></tr> <tr><td>52</td><td></td><td></td><td></td><td>46</td><td></td><td></td><td>43</td><td>41</td><td>40</td><td></td><td></td><td></td><td></td><td>20</td><td>19</td><td>18</td></tr> <tr><td colspan="2">73</td><td></td><td></td><td></td><td></td><td></td><td>27</td><td></td><td></td><td></td><td></td><td></td><td></td><td>4</td><td></td><td></td></tr> <tr><td></td><td></td><td></td><td>16</td><td>14</td><td></td><td></td><td>11</td><td></td><td>8</td><td></td><td></td><td></td><td></td><td></td><td></td><td></td></tr> </table>	72			68	67			63	62	61	60	59			55			52				46			43	41	40					20	19	18	73							27							4						16	14			11		8															
72			68	67			63	62	61	60	59			55																																																																					
52				46			43	41	40					20	19	18																																																																			
73							27							4																																																																					
			16	14			11		8																																																																										
AVAILABLE	NOT APPLICABLE	34566-7053	G	0	C	BLUE	<table border="1"> <tr><td>71</td><td>69</td><td>67</td><td>65</td><td>64</td><td>62</td><td>61</td><td>60</td><td></td><td>57</td><td></td><td>54</td><td></td><td></td><td></td><td></td><td></td></tr> <tr><td>52</td><td>51</td><td>50</td><td>49</td><td>48</td><td>47</td><td>46</td><td>45</td><td>44</td><td>42</td><td>41</td><td></td><td>37</td><td></td><td>34</td><td>33</td><td></td></tr> <tr><td colspan="2">73</td><td></td><td></td><td></td><td></td><td>28</td><td>27</td><td>26</td><td>25</td><td></td><td></td><td></td><td></td><td></td><td></td><td></td></tr> <tr><td></td><td></td><td></td><td>16</td><td>15</td><td>14</td><td>13</td><td>12</td><td>11</td><td>10</td><td>9</td><td>8</td><td>7</td><td></td><td></td><td></td><td></td></tr> </table>	71	69	67	65	64	62	61	60		57		54						52	51	50	49	48	47	46	45	44	42	41		37		34	33		73						28	27	26	25											16	15	14	13	12	11	10	9	8	7												
71	69	67	65	64	62	61	60		57		54																																																																								
52	51	50	49	48	47	46	45	44	42	41		37		34	33																																																																				
73						28	27	26	25																																																																										
			16	15	14	13	12	11	10	9	8	7																																																																							
AVAILABLE	NOT APPLICABLE	34566-7063	G	0	C	BLUE	<table border="1"> <tr><td>72</td><td>70</td><td>68</td><td>67</td><td>66</td><td></td><td>63</td><td>62</td><td></td><td>59</td><td>57</td><td></td><td></td><td></td><td>53</td><td></td><td></td></tr> <tr><td>52</td><td>51</td><td></td><td>48</td><td>47</td><td>46</td><td>44</td><td></td><td></td><td>40</td><td>39</td><td></td><td></td><td></td><td>34</td><td>33</td><td></td></tr> <tr><td colspan="2">73</td><td></td><td>32</td><td>30</td><td></td><td></td><td>26</td><td>25</td><td></td><td>22</td><td>21</td><td></td><td></td><td></td><td></td><td></td></tr> <tr><td></td><td></td><td></td><td>15</td><td>14</td><td>13</td><td></td><td>10</td><td>9</td><td></td><td>6</td><td>5</td><td>4</td><td></td><td></td><td></td><td></td></tr> </table>	72	70	68	67	66		63	62		59	57				53			52	51		48	47	46	44			40	39				34	33		73			32	30			26	25		22	21									15	14	13		10	9		6	5	4												
72	70	68	67	66		63	62		59	57				53																																																																					
52	51		48	47	46	44			40	39				34	33																																																																				
73			32	30			26	25		22	21																																																																								
			15	14	13		10	9		6	5	4																																																																							
AVAILABLE	NOT APPLICABLE	34566-7073	G	9	F	NATURAL	<table border="1"> <tr><td></td><td></td><td>69</td><td>68</td><td></td><td></td><td></td><td>43</td><td>42</td><td></td><td></td><td>58</td><td>57</td><td></td><td></td><td></td><td>33</td></tr> <tr><td colspan="2">73</td><td></td><td></td><td></td><td></td><td></td><td>30</td><td></td><td></td><td></td><td></td><td>38</td><td>37</td><td></td><td>19</td><td>18</td><td>17</td></tr> <tr><td></td><td></td><td></td><td></td><td></td><td></td><td></td><td></td><td></td><td></td><td></td><td></td><td></td><td></td><td></td><td>3</td><td>2</td><td>1</td></tr> </table>			69	68				43	42			58	57				33	73							30					38	37		19	18	17																3	2	1																							
		69	68				43	42			58	57				33																																																																			
73							30					38	37		19	18	17																																																																		
															3	2	1																																																																		
AVAILABLE	NOT APPLICABLE	34566-7083	G	9	B	ST.GRAY	<table border="1"> <tr><td></td><td></td><td></td><td></td><td></td><td></td><td></td><td></td><td></td><td></td><td></td><td></td><td></td><td></td><td></td><td></td><td></td><td></td></tr> <tr><td colspan="2">73</td><td></td><td></td><td></td><td></td><td></td><td></td><td></td><td></td><td></td><td></td><td></td><td></td><td></td><td></td><td></td><td></td></tr> <tr><td></td><td></td><td></td><td>16</td><td>15</td><td>14</td><td>13</td><td>12</td><td>11</td><td>10</td><td>8</td><td>7</td><td></td><td></td><td></td><td>3</td><td>2</td><td>1</td></tr> </table>																			73																					16	15	14	13	12	11	10	8	7				3	2	1																						
73																																																																																			
			16	15	14	13	12	11	10	8	7				3	2	1																																																																		
AVAILABLE	NOT APPLICABLE	34566-7093	G	9	B	ST.GRAY	<table border="1"> <tr><td>72</td><td>71</td><td>70</td><td>69</td><td>68</td><td>67</td><td>66</td><td>65</td><td>64</td><td>63</td><td></td><td>59</td><td></td><td></td><td></td><td></td><td>53</td></tr> <tr><td>52</td><td>51</td><td>50</td><td>49</td><td>48</td><td>47</td><td>46</td><td>45</td><td>44</td><td>43</td><td></td><td>39</td><td></td><td></td><td></td><td></td><td>34</td><td>33</td></tr> <tr><td colspan="2">73</td><td></td><td>32</td><td>31</td><td>30</td><td>29</td><td>28</td><td>27</td><td>26</td><td>25</td><td>24</td><td>23</td><td></td><td></td><td></td><td>3</td><td>2</td><td>1</td></tr> <tr><td></td><td></td><td></td><td>16</td><td>15</td><td>14</td><td>13</td><td>12</td><td>11</td><td>10</td><td>8</td><td>7</td><td></td><td></td><td></td><td></td><td></td><td></td><td></td></tr> </table>	72	71	70	69	68	67	66	65	64	63		59					53	52	51	50	49	48	47	46	45	44	43		39					34	33	73			32	31	30	29	28	27	26	25	24	23				3	2	1				16	15	14	13	12	11	10	8	7										
72	71	70	69	68	67	66	65	64	63		59					53																																																																			
52	51	50	49	48	47	46	45	44	43		39					34	33																																																																		
73			32	31	30	29	28	27	26	25	24	23				3	2	1																																																																	
			16	15	14	13	12	11	10	8	7																																																																								
AVAILABLE	NOT APPLICABLE	34566-7113	G	9	G	BLUE	<table border="1"> <tr><td>80</td><td>79</td><td>78</td><td>76</td><td></td><td></td><td>71</td><td></td><td></td><td>67</td><td></td><td></td><td></td><td></td><td></td><td></td><td></td><td></td><td></td></tr> <tr><td>60</td><td>59</td><td>58</td><td>57</td><td></td><td>54</td><td></td><td>51</td><td>50</td><td>49</td><td>48</td><td>47</td><td></td><td></td><td>44</td><td></td><td></td><td></td><td>41</td></tr> <tr><td>40</td><td>39</td><td>37</td><td></td><td></td><td>33</td><td>32</td><td></td><td>30</td><td>29</td><td>28</td><td>27</td><td></td><td>25</td><td>24</td><td></td><td></td><td></td><td></td></tr> <tr><td>20</td><td>19</td><td>18</td><td></td><td></td><td></td><td>12</td><td>11</td><td></td><td>9</td><td>8</td><td></td><td></td><td>5</td><td>3</td><td>2</td><td></td><td></td><td></td></tr> </table>	80	79	78	76			71			67										60	59	58	57		54		51	50	49	48	47			44				41	40	39	37			33	32		30	29	28	27		25	24					20	19	18				12	11		9	8			5	3	2			
80	79	78	76			71			67																																																																										
60	59	58	57		54		51	50	49	48	47			44				41																																																																	
40	39	37			33	32		30	29	28	27		25	24																																																																					
20	19	18				12	11		9	8			5	3	2																																																																				

ENTER DESCRIPTION ELEC NO: UAU2016-0232 DRAWN BY: 2015/08/14 CHKD: GJ34 APPR: VKOSHY 2015/08/14 REV: DESCRIPTION	QUALITY SYMBOLS	GENERAL TOLERANCES (UNLESS SPECIFIED)	DIMENSION STYLE	SCALE	DESIGN UNITS	THIRD ANGLE PROJECTION
	▽=0	mm INCH	MM ONLY	1:1	METRIC	
	▽=0	4 PLACES # --- # ---	DRAWN BY: SKRA JENDRANA 2011/02/14	DATE	TITLE	
	▽=0	3 PLACES # --- # ---	CHECKED BY: MVANSLAMBROU 2011/02/14	DATE		
▽=0	2 PLACES # --- # ---	APPROVED BY: DATE				
	1 PLACE # --- # ---					
	0 PLACE # --- # ---					
	ANGULAR ± ---°	DRAFT WHERE APPLICABLE MUST REMAIN WITHIN DIMENSIONS	MATERIAL NO. SEE BOM TABLE	DOCUMENT NO. SD-34566-001	SHEET NO. 77 OF 85	

MX123
66/73/80CKT
HRNS CONN ASSY
molex

THIS DRAWING CONTAINS INFORMATION THAT IS PROPRIETARY TO MOLEX INCORPORATED AND SHOULD NOT BE USED WITHOUT WRITTEN PERMISSION

STATUS	GM PART #	MATERIAL #	PART/MATERIAL REVISION	WIRE DRESS OPTION	KEY OPTION F	COLOR (TPA) F	NUMBERS INDICATE CAVITIES OPEN FOR CIRCUITS F																																																														
AVAILABLE	NOT APPLICABLE	34566-7223	G	0	C	BLUE	<table border="1"> <tr><td>72</td><td>70</td><td>68</td><td>66</td><td>63</td><td>62</td><td>59</td><td>57</td><td>53</td></tr> <tr><td>52</td><td>51</td><td>48</td><td>47</td><td>46</td><td>44</td><td>42</td><td>40</td><td>39</td><td>37</td><td>36</td><td>34</td><td>33</td></tr> <tr><td>73</td><td>32</td><td>30</td><td>26</td><td>25</td><td>24</td><td>22</td><td>21</td><td>20</td><td></td><td></td><td></td><td></td></tr> <tr><td></td><td>15</td><td>14</td><td>13</td><td>10</td><td>9</td><td>8</td><td>6</td><td>5</td><td>4</td><td>2</td><td></td><td></td></tr> </table>	72	70	68	66	63	62	59	57	53	52	51	48	47	46	44	42	40	39	37	36	34	33	73	32	30	26	25	24	22	21	20						15	14	13	10	9	8	6	5	4	2																
72	70	68	66	63	62	59	57	53																																																													
52	51	48	47	46	44	42	40	39	37	36	34	33																																																									
73	32	30	26	25	24	22	21	20																																																													
	15	14	13	10	9	8	6	5	4	2																																																											
AVAILABLE	NOT APPLICABLE	34566-7233	G	9	A	BLACK	<table border="1"> <tr><td>72</td><td></td><td></td><td></td><td></td><td></td><td>62</td><td>61</td><td></td><td></td><td>57</td><td>56</td><td>55</td><td>54</td></tr> <tr><td>52</td><td>51</td><td></td><td></td><td>46</td><td>45</td><td>43</td><td></td><td>40</td><td></td><td>37</td><td>35</td><td>34</td><td></td></tr> <tr><td>73</td><td></td><td>32</td><td>30</td><td>29</td><td></td><td>25</td><td></td><td></td><td></td><td></td><td>20</td><td></td><td></td></tr> <tr><td></td><td></td><td>16</td><td>15</td><td>13</td><td>11</td><td>10</td><td>9</td><td></td><td></td><td></td><td>4</td><td></td><td></td></tr> </table>	72						62	61			57	56	55	54	52	51			46	45	43		40		37	35	34		73		32	30	29		25					20					16	15	13	11	10	9				4								
72						62	61			57	56	55	54																																																								
52	51			46	45	43		40		37	35	34																																																									
73		32	30	29		25					20																																																										
		16	15	13	11	10	9				4																																																										
AVAILABLE	NOT APPLICABLE	34566-7243	G	9	A	BLACK	<table border="1"> <tr><td>72</td><td></td><td></td><td></td><td></td><td></td><td>62</td><td>61</td><td></td><td></td><td>58</td><td>57</td><td>56</td><td>55</td><td>54</td></tr> <tr><td>52</td><td>51</td><td></td><td>48</td><td>46</td><td>45</td><td>43</td><td>41</td><td>40</td><td></td><td>37</td><td>35</td><td>34</td><td></td><td></td></tr> <tr><td>73</td><td></td><td>32</td><td>30</td><td>29</td><td></td><td>25</td><td></td><td></td><td></td><td></td><td>20</td><td></td><td></td><td></td></tr> <tr><td></td><td></td><td>16</td><td>15</td><td>13</td><td>11</td><td>10</td><td>9</td><td></td><td></td><td></td><td>4</td><td>3</td><td></td><td></td></tr> </table>	72						62	61			58	57	56	55	54	52	51		48	46	45	43	41	40		37	35	34			73		32	30	29		25					20						16	15	13	11	10	9				4	3				
72						62	61			58	57	56	55	54																																																							
52	51		48	46	45	43	41	40		37	35	34																																																									
73		32	30	29		25					20																																																										
		16	15	13	11	10	9				4	3																																																									
AVAILABLE	NOT APPLICABLE	34822-0073	A	0	A	BLACK	<table border="1"> <tr><td>63</td><td>62</td><td>61</td><td>60</td><td>59</td><td></td><td></td><td>54</td><td>53</td><td>51</td><td>49</td><td></td><td></td><td>66</td></tr> <tr><td>47</td><td></td><td></td><td></td><td></td><td></td><td></td><td>38</td><td>37</td><td>35</td><td>33</td><td></td><td></td><td></td><td></td></tr> <tr><td>65</td><td></td><td></td><td></td><td></td><td></td><td>28</td><td></td><td>25</td><td></td><td>22</td><td>21</td><td>20</td><td>19</td><td>18</td><td>17</td></tr> <tr><td></td><td></td><td></td><td>15</td><td>14</td><td>13</td><td></td><td></td><td></td><td>8</td><td>7</td><td></td><td></td><td>3</td><td>2</td><td>1</td></tr> </table>	63	62	61	60	59			54	53	51	49			66	47							38	37	35	33					65						28		25		22	21	20	19	18	17				15	14	13				8	7			3	2	1	
63	62	61	60	59			54	53	51	49			66																																																								
47							38	37	35	33																																																											
65						28		25		22	21	20	19	18	17																																																						
			15	14	13				8	7			3	2	1																																																						
AVAILABLE	NOT APPLICABLE	34822-0083	A	9	A	BLACK	<table border="1"> <tr><td>63</td><td>62</td><td>61</td><td>60</td><td>59</td><td></td><td></td><td>54</td><td>53</td><td>51</td><td>49</td><td></td><td></td><td>66</td></tr> <tr><td>47</td><td></td><td></td><td></td><td></td><td></td><td></td><td>39</td><td>38</td><td>37</td><td>35</td><td>33</td><td></td><td></td><td></td><td></td></tr> <tr><td>65</td><td></td><td></td><td></td><td></td><td></td><td>28</td><td></td><td>25</td><td></td><td>22</td><td>21</td><td>20</td><td>19</td><td>18</td><td>17</td></tr> <tr><td></td><td></td><td></td><td>15</td><td>14</td><td>13</td><td></td><td></td><td></td><td>8</td><td>7</td><td></td><td></td><td>3</td><td>2</td><td>1</td></tr> </table>	63	62	61	60	59			54	53	51	49			66	47							39	38	37	35	33					65						28		25		22	21	20	19	18	17				15	14	13				8	7			3	2	1
63	62	61	60	59			54	53	51	49			66																																																								
47							39	38	37	35	33																																																										
65						28		25		22	21	20	19	18	17																																																						
			15	14	13				8	7			3	2	1																																																						
AVAILABLE	NOT APPLICABLE	34566-7253	G	0	B	ST.GRAY	<table border="1"> <tr><td>72</td><td></td><td></td><td></td><td></td><td></td><td>62</td><td>61</td><td></td><td></td><td></td><td></td><td></td><td></td><td></td></tr> <tr><td>52</td><td></td><td></td><td>48</td><td>47</td><td>46</td><td>44</td><td>43</td><td>41</td><td>40</td><td></td><td></td><td></td><td></td><td></td></tr> <tr><td>73</td><td></td><td></td><td>30</td><td></td><td></td><td></td><td></td><td></td><td></td><td></td><td></td><td>20</td><td>19</td><td>18</td></tr> <tr><td></td><td></td><td></td><td>16</td><td>14</td><td></td><td></td><td></td><td></td><td></td><td></td><td></td><td>4</td><td></td><td></td></tr> </table>	72						62	61								52			48	47	46	44	43	41	40						73			30									20	19	18				16	14								4				
72						62	61																																																														
52			48	47	46	44	43	41	40																																																												
73			30									20	19	18																																																							
			16	14								4																																																									
AVAILABLE	NOT APPLICABLE	34566-7263	G	0	C	BLUE	<table border="1"> <tr><td></td><td></td><td>69</td><td>67</td><td>66</td><td>64</td><td>62</td><td>60</td><td></td><td></td><td>57</td><td></td><td></td><td>54</td></tr> <tr><td>52</td><td>51</td><td>50</td><td>48</td><td>46</td><td>45</td><td>44</td><td>42</td><td></td><td></td><td>37</td><td></td><td></td><td>34</td><td>33</td></tr> <tr><td>73</td><td></td><td></td><td>32</td><td>30</td><td>28</td><td>27</td><td>26</td><td></td><td></td><td></td><td></td><td></td><td>18</td><td></td></tr> <tr><td></td><td></td><td></td><td>16</td><td>15</td><td>14</td><td>13</td><td>12</td><td>11</td><td>10</td><td>9</td><td>8</td><td>7</td><td></td><td></td></tr> </table>			69	67	66	64	62	60			57			54	52	51	50	48	46	45	44	42			37			34	33	73			32	30	28	27	26						18					16	15	14	13	12	11	10	9	8	7					
		69	67	66	64	62	60			57			54																																																								
52	51	50	48	46	45	44	42			37			34	33																																																							
73			32	30	28	27	26						18																																																								
			16	15	14	13	12	11	10	9	8	7																																																									
AVAILABLE	NOT APPLICABLE	34566-7273	G	0	C	BLUE	<table border="1"> <tr><td></td><td></td><td>69</td><td>67</td><td>66</td><td>64</td><td>62</td><td>60</td><td></td><td></td><td>57</td><td>55</td><td>54</td><td></td></tr> <tr><td>52</td><td>51</td><td>50</td><td>48</td><td>46</td><td>45</td><td>44</td><td>42</td><td></td><td></td><td>37</td><td>35</td><td>34</td><td>33</td></tr> <tr><td>73</td><td></td><td></td><td>32</td><td>30</td><td>28</td><td>27</td><td>26</td><td></td><td></td><td></td><td></td><td>19</td><td>18</td><td>17</td></tr> <tr><td></td><td></td><td></td><td>16</td><td>15</td><td>14</td><td>13</td><td>12</td><td>11</td><td>10</td><td>9</td><td>8</td><td>7</td><td></td><td></td></tr> </table>			69	67	66	64	62	60			57	55	54		52	51	50	48	46	45	44	42			37	35	34	33	73			32	30	28	27	26					19	18	17				16	15	14	13	12	11	10	9	8	7						
		69	67	66	64	62	60			57	55	54																																																									
52	51	50	48	46	45	44	42			37	35	34	33																																																								
73			32	30	28	27	26					19	18	17																																																							
			16	15	14	13	12	11	10	9	8	7																																																									
AVAILABLE	NOT APPLICABLE	34566-7283	G	0	C	BLUE	<table border="1"> <tr><td></td><td></td><td>69</td><td>67</td><td>66</td><td>64</td><td>62</td><td>60</td><td></td><td></td><td>57</td><td></td><td></td><td>54</td></tr> <tr><td>52</td><td>51</td><td>50</td><td>48</td><td>46</td><td>45</td><td>44</td><td>42</td><td></td><td></td><td>37</td><td></td><td></td><td>34</td><td>33</td></tr> <tr><td>73</td><td></td><td></td><td>32</td><td>30</td><td>28</td><td>27</td><td>26</td><td></td><td></td><td>25</td><td></td><td></td><td>18</td><td></td></tr> <tr><td></td><td></td><td></td><td>16</td><td>15</td><td>14</td><td>13</td><td>12</td><td>11</td><td>10</td><td>9</td><td>8</td><td>7</td><td></td><td></td></tr> </table>			69	67	66	64	62	60			57			54	52	51	50	48	46	45	44	42			37			34	33	73			32	30	28	27	26			25			18					16	15	14	13	12	11	10	9	8	7					
		69	67	66	64	62	60			57			54																																																								
52	51	50	48	46	45	44	42			37			34	33																																																							
73			32	30	28	27	26			25			18																																																								
			16	15	14	13	12	11	10	9	8	7																																																									

ENTER DESCRIPTION DEC NO. UAU2016-0232 DRAWN BY CHKD: APPR:VKOSHY 2015/08/14 2015/08/14	QUALITY SYMBOLS	GENERAL TOLERANCES (UNLESS SPECIFIED)	DIMENSION STYLE	SCALE	DESIGN UNITS	THIRD ANGLE PROJECTION	
	∇=0 ∇=0 ∇=0	mm INCH 4 PLACES ±--- 3 PLACES ±--- 2 PLACES ±--- 1 PLACE ±--- 0 PLACE ±---	MM ONLY	1:1	METRIC	DRAWN BY SKRA JENDRANA 2011/02/14 CHECKED BY MVANSLAMBROU 2011/02/14 APPROVED BY	MX123 66/73/80CKT HRNS CONN ASSY molex
	ANGULAR ±--- DRAFT WHERE APPLICABLE MUST REMAIN WITHIN DIMENSIONS	MATERIAL NO. SEE BOM TABLE	DOCUMENT NO. SD-34566-001	SHEET NO. 79 OF 85			
	THIS DRAWING CONTAINS INFORMATION THAT IS PROPRIETARY TO MOLEX INCORPORATED AND SHOULD NOT BE USED WITHOUT WRITTEN PERMISSION						

STATUS	GM PART #	MATERIAL #	PART/MATERIAL REVISION	WIRE DRESS OPTION	KEY OPTION P	COLOR (TPA) P	NUMBERS INDICATE CAVITIES OPEN FOR CIRCUITS P																																																																																
AVAILABLE	NOT APPLICABLE	34566-7493	G	0	C	BLUE	<table border="1"> <tr><td></td><td></td><td>69</td><td>67</td><td></td><td>64</td><td>62</td><td>60</td><td></td><td>57</td><td>55</td><td>54</td><td></td></tr> <tr><td>52</td><td>51</td><td>50</td><td>48</td><td>47</td><td>46</td><td>45</td><td>44</td><td>42</td><td></td><td>37</td><td>35</td><td>34</td><td>33</td></tr> <tr><td colspan="2">73</td><td></td><td>32</td><td></td><td></td><td>28</td><td>27</td><td>26</td><td></td><td></td><td>19</td><td>18</td><td>17</td></tr> <tr><td></td><td></td><td>16</td><td>15</td><td>14</td><td>13</td><td>12</td><td>11</td><td>10</td><td>9</td><td>8</td><td>7</td><td></td><td></td></tr> </table>			69	67		64	62	60		57	55	54		52	51	50	48	47	46	45	44	42		37	35	34	33	73			32			28	27	26			19	18	17			16	15	14	13	12	11	10	9	8	7																											
		69	67		64	62	60		57	55	54																																																																												
52	51	50	48	47	46	45	44	42		37	35	34	33																																																																										
73			32			28	27	26			19	18	17																																																																										
		16	15	14	13	12	11	10	9	8	7																																																																												
AVAILABLE	NOT APPLICABLE	34566-7513	G	9	A	BLACK	<table border="1"> <tr><td>72</td><td>71</td><td>70</td><td>69</td><td>68</td><td>66</td><td>65</td><td>64</td><td>63</td><td>61</td><td>60</td><td></td><td>57</td><td>56</td><td>54</td><td>53</td></tr> <tr><td>52</td><td>51</td><td>50</td><td>49</td><td>48</td><td>46</td><td>45</td><td>44</td><td>43</td><td></td><td>40</td><td>39</td><td>38</td><td>37</td><td>36</td><td>34</td><td>33</td></tr> <tr><td colspan="2">73</td><td></td><td>32</td><td>31</td><td>30</td><td>29</td><td>28</td><td></td><td></td><td></td><td>23</td><td>22</td><td>21</td><td>20</td><td></td><td></td></tr> <tr><td></td><td></td><td>15</td><td>14</td><td>13</td><td>12</td><td></td><td></td><td></td><td></td><td>7</td><td>6</td><td>5</td><td>4</td><td></td><td>2</td><td></td></tr> </table>	72	71	70	69	68	66	65	64	63	61	60		57	56	54	53	52	51	50	49	48	46	45	44	43		40	39	38	37	36	34	33	73			32	31	30	29	28				23	22	21	20					15	14	13	12					7	6	5	4		2														
72	71	70	69	68	66	65	64	63	61	60		57	56	54	53																																																																								
52	51	50	49	48	46	45	44	43		40	39	38	37	36	34	33																																																																							
73			32	31	30	29	28				23	22	21	20																																																																									
		15	14	13	12					7	6	5	4		2																																																																								
AVAILABLE	NOT APPLICABLE	34566-7523	G	0	A	BLACK	<table border="1"> <tr><td>72</td><td></td><td></td><td></td><td></td><td></td><td></td><td>64</td><td>62</td><td>61</td><td></td><td>59</td><td>58</td><td>57</td><td>56</td><td>55</td><td>54</td></tr> <tr><td>52</td><td>51</td><td></td><td>48</td><td>47</td><td>46</td><td>45</td><td>43</td><td>41</td><td>40</td><td></td><td></td><td></td><td>37</td><td></td><td></td><td>33</td></tr> <tr><td colspan="2">73</td><td></td><td>32</td><td>30</td><td>29</td><td>27</td><td>26</td><td>25</td><td>24</td><td></td><td></td><td></td><td></td><td>20</td><td></td><td></td></tr> <tr><td></td><td></td><td>16</td><td>15</td><td>13</td><td>11</td><td>10</td><td>9</td><td></td><td></td><td></td><td></td><td></td><td>4</td><td></td><td></td><td></td></tr> </table>	72							64	62	61		59	58	57	56	55	54	52	51		48	47	46	45	43	41	40				37			33	73			32	30	29	27	26	25	24					20					16	15	13	11	10	9						4															
72							64	62	61		59	58	57	56	55	54																																																																							
52	51		48	47	46	45	43	41	40				37			33																																																																							
73			32	30	29	27	26	25	24					20																																																																									
		16	15	13	11	10	9						4																																																																										
AVAILABLE	NOT APPLICABLE	34566-7533	G	0	G	BLUE	<table border="1"> <tr><td>80</td><td>79</td><td>78</td><td></td><td></td><td></td><td></td><td>71</td><td>70</td><td></td><td>67</td><td></td><td></td><td></td><td></td><td></td><td></td></tr> <tr><td>60</td><td>59</td><td>58</td><td>57</td><td></td><td>54</td><td></td><td>51</td><td>50</td><td>49</td><td>48</td><td>47</td><td></td><td>45</td><td>44</td><td></td><td>42</td><td>41</td></tr> <tr><td>40</td><td>39</td><td></td><td>37</td><td>36</td><td></td><td>34</td><td>33</td><td>32</td><td>30</td><td>29</td><td>28</td><td>27</td><td>25</td><td>24</td><td>23</td><td>22</td><td>21</td></tr> <tr><td>20</td><td>19</td><td>18</td><td></td><td></td><td></td><td>13</td><td>12</td><td>11</td><td>9</td><td>8</td><td></td><td></td><td>5</td><td>3</td><td>2</td><td>1</td><td></td></tr> </table>	80	79	78					71	70		67							60	59	58	57		54		51	50	49	48	47		45	44		42	41	40	39		37	36		34	33	32	30	29	28	27	25	24	23	22	21	20	19	18				13	12	11	9	8			5	3	2	1										
80	79	78					71	70		67																																																																													
60	59	58	57		54		51	50	49	48	47		45	44		42	41																																																																						
40	39		37	36		34	33	32	30	29	28	27	25	24	23	22	21																																																																						
20	19	18				13	12	11	9	8			5	3	2	1																																																																							
AVAILABLE	NOT APPLICABLE	34566-7543 SAME AS P/N 35466-1553	G	0	A	BLACK	<table border="1"> <tr><td></td><td></td><td></td><td></td><td></td><td></td><td></td><td></td><td></td><td></td><td></td><td></td><td></td><td></td><td></td><td></td><td></td><td></td></tr> <tr><td colspan="2">73</td><td></td><td></td><td></td><td></td><td></td><td></td><td></td><td></td><td></td><td></td><td></td><td></td><td></td><td></td><td></td><td></td></tr> </table>																			73																																																													
73																																																																																							
AVAILABLE	NOT APPLICABLE	34566-7553 SAME AS P/N 35466-1983	G	0	B	ST.GRAY	<table border="1"> <tr><td></td><td></td><td></td><td></td><td></td><td></td><td></td><td></td><td></td><td></td><td></td><td></td><td></td><td></td><td></td><td></td><td></td><td></td></tr> <tr><td colspan="2">73</td><td></td><td></td><td></td><td></td><td></td><td></td><td></td><td></td><td></td><td></td><td></td><td></td><td></td><td></td><td></td><td></td></tr> </table>																			73																																																													
73																																																																																							
AVAILABLE	NOT APPLICABLE	34566-7563 SAME AS P/N 35466-1993	G	0	C	BLUE	<table border="1"> <tr><td></td><td></td><td></td><td></td><td></td><td></td><td></td><td></td><td></td><td></td><td></td><td></td><td></td><td></td><td></td><td></td><td></td><td></td></tr> <tr><td colspan="2">73</td><td></td><td></td><td></td><td></td><td></td><td></td><td></td><td></td><td></td><td></td><td></td><td></td><td></td><td></td><td></td><td></td></tr> </table>																			73																																																													
73																																																																																							
AVAILABLE	NOT APPLICABLE	34566-7573	G	0	B	ST.GRAY	<table border="1"> <tr><td>72</td><td>70</td><td></td><td>68</td><td></td><td></td><td></td><td></td><td>62</td><td>61</td><td></td><td></td><td></td><td></td><td></td><td></td><td>55</td><td></td></tr> <tr><td>52</td><td></td><td></td><td>48</td><td>47</td><td>46</td><td></td><td></td><td>43</td><td>40</td><td></td><td></td><td></td><td></td><td>22</td><td>21</td><td>20</td><td>19</td><td>18</td><td>17</td></tr> <tr><td colspan="2">73</td><td></td><td>16</td><td>15</td><td>14</td><td></td><td></td><td></td><td></td><td>8</td><td>6</td><td>4</td><td></td><td></td><td></td><td></td><td></td><td></td><td>2</td></tr> </table>	72	70		68					62	61							55		52			48	47	46			43	40					22	21	20	19	18	17	73			16	15	14					8	6	4							2																						
72	70		68					62	61							55																																																																							
52			48	47	46			43	40					22	21	20	19	18	17																																																																				
73			16	15	14					8	6	4							2																																																																				
AVAILABLE	NOT APPLICABLE	34566-7583	G	9	A	BLACK	<table border="1"> <tr><td>72</td><td>70</td><td></td><td>67</td><td></td><td></td><td></td><td>63</td><td></td><td>60</td><td>59</td><td>58</td><td>57</td><td></td><td></td><td></td><td></td><td></td></tr> <tr><td>52</td><td></td><td></td><td>48</td><td>47</td><td>46</td><td></td><td>43</td><td>42</td><td>40</td><td>39</td><td>38</td><td>37</td><td></td><td></td><td></td><td></td><td></td><td></td><td></td></tr> <tr><td colspan="2">73</td><td></td><td>32</td><td>31</td><td>30</td><td>29</td><td>28</td><td>27</td><td></td><td></td><td></td><td>22</td><td>21</td><td></td><td></td><td></td><td></td><td></td><td>2</td><td>1</td></tr> <tr><td></td><td></td><td>16</td><td>15</td><td>14</td><td>13</td><td>12</td><td>11</td><td>9</td><td>7</td><td></td><td></td><td></td><td></td><td></td><td></td><td></td><td></td><td></td><td></td><td></td></tr> </table>	72	70		67				63		60	59	58	57						52			48	47	46		43	42	40	39	38	37								73			32	31	30	29	28	27				22	21						2	1			16	15	14	13	12	11	9	7											
72	70		67				63		60	59	58	57																																																																											
52			48	47	46		43	42	40	39	38	37																																																																											
73			32	31	30	29	28	27				22	21						2	1																																																																			
		16	15	14	13	12	11	9	7																																																																														

ENTER DESCRIPTION DEC NO. UAU2016-0232 DRAWN BY GJ34 CHKD: APPR:VKOSHY 2015/08/14 2015/08/14	QUALITY SYMBOLS	GENERAL TOLERANCES (UNLESS SPECIFIED)	DIMENSION STYLE	SCALE	DESIGN UNITS	THIRD ANGLE PROJECTION	
	▽=0	mm INCH	MM ONLY	1:1	METRIC		
	▽=0	4 PLACES ± --- ± --- 3 PLACES ± --- ± --- 2 PLACES ± --- ± --- 1 PLACE ± --- ± --- 0 PLACE ± --- ± ---	DRAWN BY DATE SKRA JENDRANA 2011/02/14	TITLE MX123 66/73/80CKT HRNS CONN ASSY			
	▽=0	ANGULAR ± --- DRAFT WHERE APPLICABLE MUST REMAIN WITHIN DIMENSIONS	CHECKED BY DATE MVANSLAMBROU 2011/02/14	APPROVED BY DATE			
			MATERIAL NO.	DOCUMENT NO.	SHEET NO.		
			SEE BOM TABLE	SD-34566-001	82 OF 85		
			THIS DRAWING CONTAINS INFORMATION THAT IS PROPRIETARY TO MOLEX INCORPORATED AND SHOULD NOT BE USED WITHOUT WRITTEN PERMISSION				

STATUS	GM PART #	MATERIAL #	PART/MATERIAL REVISION	WIRE DRESS OPTION	KEY OPTION Φ	COLOR (TPA) Φ	NUMBERS INDICATE CAVITIES OPEN FOR CIRCUITS Φ																																																																												
AVAILABLE	NOT APPLICABLE	34566-7593	G	9	A	BLACK	<table border="1"> <tr><td>72</td><td>70</td><td>69</td><td>68</td><td></td><td></td><td>64</td><td>62</td><td>61</td><td></td><td>59</td><td>58</td><td>57</td><td>56</td><td>55</td><td>54</td><td>53</td></tr> <tr><td>52</td><td>51</td><td>50</td><td>48</td><td>47</td><td>46</td><td>45</td><td>43</td><td>41</td><td>40</td><td></td><td></td><td>37</td><td>35</td><td></td><td></td><td>33</td></tr> <tr><td colspan="2">73</td><td></td><td>32</td><td>30</td><td>29</td><td>27</td><td>26</td><td>25</td><td>24</td><td></td><td></td><td></td><td>20</td><td>19</td><td>18</td><td></td></tr> <tr><td></td><td></td><td></td><td>16</td><td>15</td><td>14</td><td>13</td><td>12</td><td>11</td><td>10</td><td>9</td><td>8</td><td></td><td>5</td><td>4</td><td>3</td><td>2</td><td>1</td></tr> </table>	72	70	69	68			64	62	61		59	58	57	56	55	54	53	52	51	50	48	47	46	45	43	41	40			37	35			33	73			32	30	29	27	26	25	24				20	19	18					16	15	14	13	12	11	10	9	8		5	4	3	2	1							
72	70	69	68			64	62	61		59	58	57	56	55	54	53																																																																			
52	51	50	48	47	46	45	43	41	40			37	35			33																																																																			
73			32	30	29	27	26	25	24				20	19	18																																																																				
			16	15	14	13	12	11	10	9	8		5	4	3	2	1																																																																		
AVAILABLE	NOT APPLICABLE	34822-0093	A	9	A	BLACK	<table border="1"> <tr><td>63</td><td>62</td><td>61</td><td>60</td><td>59</td><td></td><td></td><td>54</td><td>53</td><td></td><td>51</td><td>49</td><td></td><td></td><td></td><td></td><td></td><td></td></tr> <tr><td>47</td><td></td><td></td><td></td><td></td><td></td><td></td><td>38</td><td>37</td><td></td><td>35</td><td>33</td><td></td><td></td><td>66</td><td></td><td></td><td></td></tr> <tr><td colspan="2">65</td><td></td><td></td><td></td><td></td><td></td><td></td><td>25</td><td></td><td>22</td><td>21</td><td>20</td><td>19</td><td>18</td><td>17</td><td></td><td></td></tr> <tr><td></td><td></td><td></td><td></td><td>15</td><td>14</td><td>13</td><td></td><td></td><td></td><td>8</td><td>7</td><td></td><td></td><td></td><td></td><td></td><td></td></tr> </table>	63	62	61	60	59			54	53		51	49							47							38	37		35	33			66				65								25		22	21	20	19	18	17							15	14	13				8	7										
63	62	61	60	59			54	53		51	49																																																																								
47							38	37		35	33			66																																																																					
65								25		22	21	20	19	18	17																																																																				
				15	14	13				8	7																																																																								
AVAILABLE	NOT APPLICABLE	34822-0103	A	0	A	BLACK	<table border="1"> <tr><td>63</td><td></td><td></td><td></td><td></td><td>58</td><td>57</td><td>56</td><td>55</td><td>54</td><td>53</td><td></td><td>51</td><td>49</td><td></td><td></td><td></td><td></td></tr> <tr><td></td><td></td><td></td><td></td><td></td><td></td><td>41</td><td>40</td><td>38</td><td>37</td><td>35</td><td>33</td><td></td><td></td><td>66</td><td></td><td></td><td></td></tr> <tr><td colspan="2">65</td><td></td><td></td><td></td><td></td><td></td><td>28</td><td>27</td><td>26</td><td>25</td><td></td><td>22</td><td></td><td></td><td>18</td><td>17</td><td></td></tr> <tr><td></td><td></td><td></td><td></td><td></td><td></td><td>14</td><td></td><td></td><td></td><td></td><td>7</td><td></td><td></td><td></td><td></td><td></td><td></td></tr> </table>	63					58	57	56	55	54	53		51	49											41	40	38	37	35	33			66				65							28	27	26	25		22			18	17								14					7										
63					58	57	56	55	54	53		51	49																																																																						
						41	40	38	37	35	33			66																																																																					
65							28	27	26	25		22			18	17																																																																			
						14					7																																																																								
AVAILABLE	NOT APPLICABLE	34822-0113	A	9	A	BLACK	<table border="1"> <tr><td></td><td></td><td>61</td><td>60</td><td>59</td><td>58</td><td></td><td>56</td><td>55</td><td></td><td></td><td>51</td><td>49</td><td></td><td></td><td></td><td></td><td></td></tr> <tr><td colspan="2">65</td><td></td><td></td><td></td><td>42</td><td></td><td></td><td></td><td></td><td></td><td></td><td></td><td></td><td></td><td></td><td></td><td></td></tr> <tr><td></td><td></td><td></td><td></td><td></td><td></td><td></td><td></td><td></td><td></td><td>10</td><td>8</td><td></td><td></td><td></td><td></td><td></td><td></td></tr> <tr><td></td><td></td><td></td><td></td><td></td><td></td><td></td><td></td><td></td><td></td><td></td><td></td><td></td><td></td><td></td><td></td><td></td><td>17</td></tr> </table>			61	60	59	58		56	55			51	49						65					42																							10	8																								17				
		61	60	59	58		56	55			51	49																																																																							
65					42																																																																														
										10	8																																																																								
																	17																																																																		
AVAILABLE	NOT APPLICABLE	34822-0123	A	9	C	BLUE	<table border="1"> <tr><td>64</td><td>63</td><td>62</td><td>61</td><td>60</td><td></td><td></td><td></td><td>55</td><td>54</td><td></td><td></td><td></td><td></td><td></td><td></td><td></td><td></td></tr> <tr><td>48</td><td>47</td><td>46</td><td>45</td><td></td><td></td><td></td><td>42</td><td></td><td>39</td><td></td><td></td><td>36</td><td>35</td><td></td><td></td><td></td><td>66</td></tr> <tr><td colspan="2">65</td><td></td><td></td><td></td><td></td><td></td><td></td><td></td><td>27</td><td></td><td></td><td></td><td></td><td></td><td></td><td>19</td><td></td></tr> <tr><td></td><td></td><td></td><td></td><td></td><td></td><td></td><td></td><td></td><td></td><td>10</td><td></td><td></td><td>6</td><td></td><td>4</td><td></td><td>1</td></tr> </table>	64	63	62	61	60				55	54									48	47	46	45				42		39			36	35				66	65									27							19												10			6		4		1				
64	63	62	61	60				55	54																																																																										
48	47	46	45				42		39			36	35				66																																																																		
65									27							19																																																																			
										10			6		4		1																																																																		
AVAILABLE	NOT APPLICABLE	34566-7613	G	9	H	ST.GRAY	<table border="1"> <tr><td>80</td><td>79</td><td>78</td><td></td><td></td><td>75</td><td></td><td></td><td></td><td>71</td><td>70</td><td></td><td></td><td>67</td><td></td><td></td><td></td><td></td></tr> <tr><td>60</td><td>59</td><td>57</td><td></td><td></td><td>54</td><td></td><td></td><td></td><td>51</td><td>50</td><td>49</td><td>48</td><td>47</td><td>45</td><td>44</td><td></td><td>42</td><td>41</td></tr> <tr><td>40</td><td>39</td><td>37</td><td>36</td><td></td><td>34</td><td>33</td><td>32</td><td></td><td>30</td><td>29</td><td>28</td><td>27</td><td>25</td><td>24</td><td>23</td><td>22</td><td>21</td><td></td></tr> <tr><td>20</td><td>18</td><td></td><td></td><td></td><td></td><td>13</td><td>12</td><td>11</td><td>9</td><td>8</td><td></td><td></td><td>5</td><td></td><td>3</td><td>2</td><td>1</td><td></td></tr> </table>	80	79	78			75				71	70			67					60	59	57			54				51	50	49	48	47	45	44		42	41	40	39	37	36		34	33	32		30	29	28	27	25	24	23	22	21		20	18					13	12	11	9	8			5		3	2	1		
80	79	78			75				71	70			67																																																																						
60	59	57			54				51	50	49	48	47	45	44		42	41																																																																	
40	39	37	36		34	33	32		30	29	28	27	25	24	23	22	21																																																																		
20	18					13	12	11	9	8			5		3	2	1																																																																		
AVAILABLE	NOT APPLICABLE	34566-7623	G	9	G	BLUE	<table border="1"> <tr><td>80</td><td>79</td><td>78</td><td></td><td></td><td>75</td><td></td><td></td><td></td><td>71</td><td>70</td><td></td><td></td><td>67</td><td></td><td></td><td></td><td></td><td></td></tr> <tr><td>60</td><td>59</td><td>58</td><td>57</td><td></td><td>54</td><td></td><td></td><td></td><td>51</td><td>50</td><td>49</td><td>48</td><td>47</td><td>45</td><td>44</td><td></td><td>42</td><td>41</td></tr> <tr><td>40</td><td>39</td><td>37</td><td>36</td><td></td><td>34</td><td>33</td><td>32</td><td></td><td>30</td><td>29</td><td>28</td><td>27</td><td>25</td><td>24</td><td>23</td><td>22</td><td>21</td><td></td></tr> <tr><td>20</td><td>19</td><td>18</td><td></td><td></td><td></td><td>13</td><td>12</td><td>11</td><td>9</td><td>8</td><td></td><td></td><td>5</td><td></td><td>3</td><td>2</td><td>1</td><td></td></tr> </table>	80	79	78			75				71	70			67						60	59	58	57		54				51	50	49	48	47	45	44		42	41	40	39	37	36		34	33	32		30	29	28	27	25	24	23	22	21		20	19	18				13	12	11	9	8			5		3	2	1	
80	79	78			75				71	70			67																																																																						
60	59	58	57		54				51	50	49	48	47	45	44		42	41																																																																	
40	39	37	36		34	33	32		30	29	28	27	25	24	23	22	21																																																																		
20	19	18				13	12	11	9	8			5		3	2	1																																																																		
AVAILABLE	NOT APPLICABLE	34822-0133	A	0	C	BLUE	<table border="1"> <tr><td>64</td><td>63</td><td>62</td><td>61</td><td>60</td><td></td><td></td><td></td><td>55</td><td>54</td><td></td><td></td><td></td><td></td><td></td><td></td><td></td><td></td><td></td></tr> <tr><td>48</td><td>47</td><td>46</td><td>45</td><td></td><td></td><td></td><td>42</td><td></td><td>39</td><td></td><td></td><td>36</td><td>35</td><td></td><td></td><td></td><td></td><td>66</td></tr> <tr><td colspan="2">65</td><td></td><td></td><td></td><td></td><td></td><td></td><td></td><td>27</td><td></td><td></td><td></td><td></td><td></td><td></td><td>19</td><td></td><td></td></tr> <tr><td></td><td></td><td></td><td></td><td></td><td></td><td></td><td></td><td></td><td></td><td>10</td><td></td><td></td><td>6</td><td></td><td>4</td><td></td><td></td><td>1</td></tr> </table>	64	63	62	61	60				55	54										48	47	46	45				42		39			36	35					66	65									27							19													10			6		4			1
64	63	62	61	60				55	54																																																																										
48	47	46	45				42		39			36	35					66																																																																	
65									27							19																																																																			
										10			6		4			1																																																																	
AVAILABLE	NOT APPLICABLE	34566-7633	G	9	A	BLACK	<table border="1"> <tr><td>72</td><td>71</td><td>70</td><td>69</td><td>68</td><td>67</td><td>66</td><td>65</td><td>64</td><td>63</td><td></td><td></td><td>60</td><td>59</td><td>58</td><td>57</td><td>56</td><td>55</td><td>54</td></tr> <tr><td>52</td><td>51</td><td>50</td><td>49</td><td>48</td><td>47</td><td>46</td><td>45</td><td>44</td><td>43</td><td>42</td><td>41</td><td>40</td><td>39</td><td>38</td><td>37</td><td>36</td><td>35</td><td>34</td></tr> <tr><td colspan="2">73</td><td></td><td></td><td>32</td><td>31</td><td>30</td><td>29</td><td>28</td><td>27</td><td>26</td><td>25</td><td></td><td>23</td><td>22</td><td>21</td><td>20</td><td>18</td><td>17</td></tr> <tr><td></td><td></td><td></td><td></td><td>16</td><td>15</td><td>14</td><td>13</td><td>12</td><td>11</td><td>9</td><td>8</td><td>7</td><td>6</td><td>5</td><td>4</td><td>3</td><td>2</td><td>1</td></tr> </table>	72	71	70	69	68	67	66	65	64	63			60	59	58	57	56	55	54	52	51	50	49	48	47	46	45	44	43	42	41	40	39	38	37	36	35	34	73				32	31	30	29	28	27	26	25		23	22	21	20	18	17					16	15	14	13	12	11	9	8	7	6	5	4	3	2	1
72	71	70	69	68	67	66	65	64	63			60	59	58	57	56	55	54																																																																	
52	51	50	49	48	47	46	45	44	43	42	41	40	39	38	37	36	35	34																																																																	
73				32	31	30	29	28	27	26	25		23	22	21	20	18	17																																																																	
				16	15	14	13	12	11	9	8	7	6	5	4	3	2	1																																																																	

ENTER DESCRIPTION DEC NO: JAU2016-0232 DRAWN BY: CHYK G34 APPR: WKSHY 2015/08/14 2015/08/14	QUALITY SYMBOLS	GENERAL TOLERANCES (UNLESS SPECIFIED)	DIMENSION STYLE	SCALE	DESIGN UNITS	THIRD ANGLE PROJECTION	
	∇=0 ∇=0 ∇=0	mm INCH 4 PLACES # --- ± --- 3 PLACES # --- ± --- 2 PLACES # --- ± --- 1 PLACE # --- ± --- 0 PLACE # --- ± ---	MM ONLY	1:1	METRIC	DRAWN BY: SKRA JENDRANA 2011/02/14 CHECKED BY: MVANSLAMBROU 2011/02/14 APPROVED BY:	DATE: _____ DATE: _____ DATE: _____
	ANGULAR ± --- DRAFT WHERE APPLICABLE MUST REMAIN WITHIN DIMENSIONS		SEE BOM TABLE THIS DRAWING CONTAINS INFORMATION THAT IS PROPRIETARY TO MOLEX INCORPORATED AND SHOULD NOT BE USED WITHOUT WRITTEN PERMISSION	MATERIAL NO. SD-34566-001 DOCUMENT NO. SD-34566-001	SHEET NO. 83 OF 85		

STATUS	GM PART #	MATERIAL #	PART/MATERIAL REVISION	WIRE DRESS OPTION	KEY OPTION Γ	COLOR (TFA) Γ	NUMBERS INDICATE CAVITIES OPEN FOR CIRCUITS Γ																																																																												
AVAILABLE	NOT APPLICABLE	34566-7733	A	9	A	BLACK	<table border="1"> <tr><td>72</td><td></td><td></td><td></td><td></td><td></td><td>64</td><td>62</td><td>61</td><td></td><td>58</td><td>57</td><td>56</td><td>55</td><td>54</td><td>53</td></tr> <tr><td>52</td><td>51</td><td></td><td>48</td><td>46</td><td>45</td><td>43</td><td>41</td><td>40</td><td></td><td></td><td>37</td><td></td><td></td><td></td><td></td></tr> <tr><td colspan="2">73</td><td></td><td>32</td><td>30</td><td>29</td><td>27</td><td>25</td><td></td><td></td><td></td><td></td><td>20</td><td></td><td></td><td></td></tr> <tr><td colspan="2"></td><td></td><td>16</td><td>15</td><td>13</td><td>11</td><td>10</td><td>9</td><td></td><td></td><td></td><td>4</td><td>3</td><td></td><td></td></tr> </table>	72						64	62	61		58	57	56	55	54	53	52	51		48	46	45	43	41	40			37					73			32	30	29	27	25					20							16	15	13	11	10	9				4	3														
72						64	62	61		58	57	56	55	54	53																																																																				
52	51		48	46	45	43	41	40			37																																																																								
73			32	30	29	27	25					20																																																																							
			16	15	13	11	10	9				4	3																																																																						
AVAILABLE	NOT APPLICABLE	34566-7743	G	0	C	BLUE	<table border="1"> <tr><td>72</td><td>70</td><td>68</td><td>67</td><td>66</td><td></td><td>63</td><td>62</td><td></td><td>59</td><td>57</td><td></td><td></td><td></td><td>53</td></tr> <tr><td>52</td><td>51</td><td>49</td><td>48</td><td>47</td><td>46</td><td>44</td><td></td><td>41</td><td>40</td><td>39</td><td>37</td><td>36</td><td>35</td><td>34</td><td>33</td></tr> <tr><td colspan="2">73</td><td></td><td>32</td><td>30</td><td></td><td>27</td><td>26</td><td>25</td><td>24</td><td>22</td><td>21</td><td>20</td><td></td><td></td><td></td></tr> <tr><td colspan="2"></td><td></td><td>15</td><td>14</td><td>13</td><td></td><td>10</td><td>9</td><td>8</td><td>6</td><td>5</td><td>4</td><td>2</td><td></td><td></td></tr> </table>	72	70	68	67	66		63	62		59	57				53	52	51	49	48	47	46	44		41	40	39	37	36	35	34	33	73			32	30		27	26	25	24	22	21	20							15	14	13		10	9	8	6	5	4	2															
72	70	68	67	66		63	62		59	57				53																																																																					
52	51	49	48	47	46	44		41	40	39	37	36	35	34	33																																																																				
73			32	30		27	26	25	24	22	21	20																																																																							
			15	14	13		10	9	8	6	5	4	2																																																																						
634 AVAILABLE	NOT APPLICABLE	34566-7753	G	0	A	BLACK	<table border="1"> <tr><td></td><td>71</td><td>70</td><td>69</td><td>68</td><td>67</td><td></td><td>64</td><td>63</td><td>62</td><td>61</td><td>60</td><td>59</td><td>58</td><td>57</td><td>56</td><td>55</td><td>54</td><td>53</td></tr> <tr><td>52</td><td>51</td><td>50</td><td>49</td><td></td><td></td><td></td><td>45</td><td>44</td><td>43</td><td>42</td><td>41</td><td>39</td><td>38</td><td>37</td><td>36</td><td></td><td></td><td>34</td></tr> <tr><td colspan="2">73</td><td></td><td>32</td><td>31</td><td></td><td></td><td>29</td><td>28</td><td>27</td><td>26</td><td>25</td><td></td><td></td><td></td><td></td><td></td><td>19</td><td>18</td></tr> <tr><td colspan="2"></td><td></td><td>16</td><td>15</td><td>14</td><td>13</td><td>12</td><td>11</td><td>10</td><td>9</td><td>8</td><td></td><td></td><td></td><td></td><td></td><td>3</td><td></td></tr> </table>		71	70	69	68	67		64	63	62	61	60	59	58	57	56	55	54	53	52	51	50	49				45	44	43	42	41	39	38	37	36			34	73			32	31			29	28	27	26	25						19	18				16	15	14	13	12	11	10	9	8						3	
	71	70	69	68	67		64	63	62	61	60	59	58	57	56	55	54	53																																																																	
52	51	50	49				45	44	43	42	41	39	38	37	36			34																																																																	
73			32	31			29	28	27	26	25						19	18																																																																	
			16	15	14	13	12	11	10	9	8						3																																																																		

ENTER DESCRIPTION DEC NO: JAU2016-0232 DRAWN BY: CHKD: APPR: WOSHY 2015/08/14 2015/08/14 634	QUALITY SYMBOLS	GENERAL TOLERANCES (UNLESS SPECIFIED)	DIMENSION STYLE	SCALE	DESIGN UNITS	THIRD ANGLE PROJECTION
	$\nabla=0$	4 PLACES # --- # ---	MM ONLY	1:1	METRIC	
	$\nabla=0$	3 PLACES # --- # ---	mm INCH			
	$\nabla=0$	2 PLACES # --- # ---				
	1 PLACE # --- # ---					
	0 PLACE # --- # ---					
	ANGULAR \pm ---					
	DRAFT WHERE APPLICABLE MUST REMAIN WITHIN DIMENSIONS					
			DRAWN BY: SKRA JENDRANA	DATE: 2011/02/14	TITLE: MX123 66/73/80CKT HRNS CONN ASSY	
			CHECKED BY: MVANSLAMBROU	DATE: 2011/02/14	molex	
			APPROVED BY:	DATE:		
			MATERIAL NO. SEE BOM TABLE	DOCUMENT NO. SD-34566-001		
						SHEET NO. 85 OF 85
						THIS DRAWING CONTAINS INFORMATION THAT IS PROPRIETARY TO MOLEX INCORPORATED AND SHOULD NOT BE USED WITHOUT WRITTEN PERMISSION