

Microcontrollers and development tools

EMBEDDED SOLUTIONS

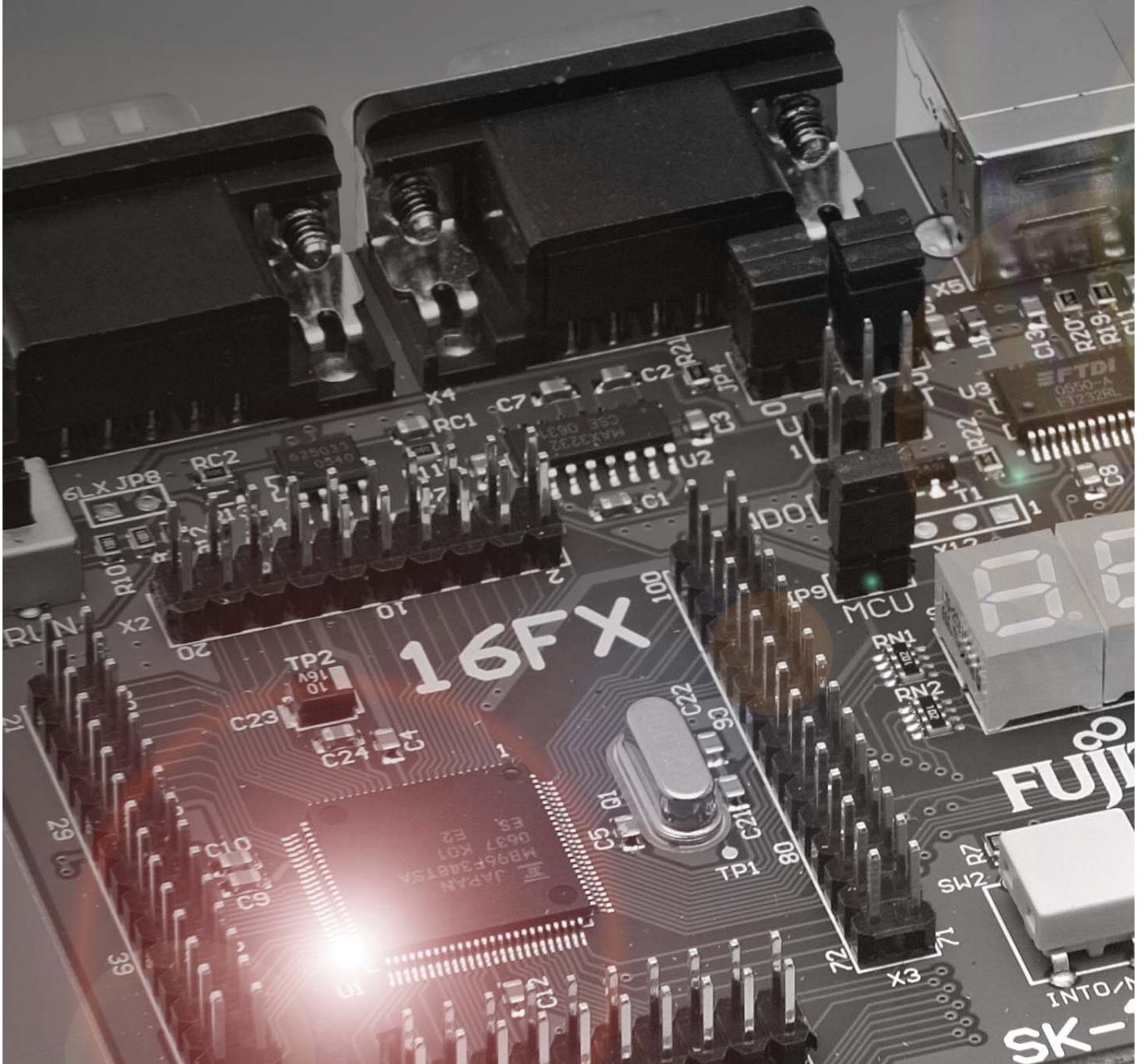

PRODUCT OVERVIEW

MICROCONTROLLERS

| CONTENTS | |
|---|-----------|
| Introducing Fujitsu Microelectronics Europe | 1 |
| Expertise in the automotive and industrial markets | 2-3 |
| Automotive strengths | 4 |
| New 8-bit MCU family - F ² MC-8FX CPU-core architecture | 5 |
| New 8-bit MCU family - F ² MC-8FX | 6-7 |
| New 8-bit MCU family - F ² MC-8FX product details | 8 |
| 8-bit F ² MC-8L product line-up | 9 |
| 8-bit F ² MC-8FX product line-up | 10 |
| F²MC-16 CPU-core architecture | 11 |
| The new 16-bit MCU family: F ² MC-16FX | 12 |
| Features of 16-bit families | 13 |
| F ² MC-16LX & 16FX product line-up | 14-17 |
| Embedded Flash technology | 18 |
| 16-bit single CAN bus microcontrollers (100-pin) MB90340 | 19 |
| 16-bit single CAN bus microcontrollers (64-pin) MB90350 | 20 |
| 16-bit CAN bus microcontrollers (48-pin) MB90360 | 21 |
| 16-bit double CAN bus microcontrollers (120-pin) MB90390 | 22 |
| 16-bit USB microcontrollers MB90330/335 | 23 |
| 16-bit FX block diagrams | 24 |
| 16-bit F ² MC-LX compatibility overview | 25-26 |
| 16-bit support tools | 27 |
| Evaluation boards | 28-30 |
| Introduction to the FR family - 32-bit RISC architecture | 31 |
| MB91270 automotive series | 32 |
| MB91360G automotive series | 33 |
| MB91460 automotive series | 34-37 |
| MB88121 FlexRay communication controller | 38 |
| MB91260/265 series - 3-phase motor control | 39 |
| Next generation 32-bit motor control MCUs | 40 |
| MB91301 series | 41 |
| MB91350A series | 42 |
| FR series in-circuit emulator | 43 |
| FR series evaluation boards | 43-45 |
| 32-bit FR product line-up | 46-47 |
| Integrated software development environment- Solutions for V | 48 |
| Softune - Fujitsu's integrated software development package | 49 |
| Accemic MDE monitor debugger | 50 |
| Galep IV universal serial/parallel MCU programmer | 51 |
| Real-time operating systems | 52-53 |
| Notes | 54-55 |
| EMEA Distributors | 56-57 |

Copyright © 2007 Fujitsu Limited Tokyo, Japan and Fujitsu Microelectronics Europe GmbH. All Rights Reserved.

The information contained in this document has been carefully checked and is believed to be entirely reliable. However Fujitsu and its subsidiaries assume no responsibility for inaccuracies.

The information contained in this document does not convey any licence under the copyrights, patent rights or trademarks claimed and owned by Fujitsu. Fujitsu Limited and its subsidiaries reserve the right to change products or specifications without notice.

No part of this publication may be copied or reproduced in any form or by any means or transferred to any third party without the prior consent of Fujitsu.

Designed and produced in the UK. Printed on environmentally friendly paper.

Introducing **FUJITSU MICROELECTRONICS EUROPE**

Fujitsu Microelectronics Europe (FME) is a major supplier of semiconductor products to the European and global market. The company's main business focus is on providing system solutions to the automotive, industrial/home appliance, networking/telecommunications and multimedia markets.

The engineering support from experts in both the application areas and Fujitsu products saves customers time and effort.

Fujitsu offers a broad range of semiconductor devices, including sensors, ASICs, RF devices, MPEG encoders & decoders, microcontrollers, graphics controllers, microprocessors, FRAM and FCRAM™. The company is also a leader in colour plasma display panels.



Fujitsu Microelectronic Europe's headquarters in Langen.



Fujitsu's design centres and sales offices.

Expertise in the **AUTOMOTIVE & INDUSTRIAL MARKETS**

Fujitsu's microcontroller product portfolio of more than 500 products is based on 8-,16- and 32-bit architectures and is the result of continuous development activity. The basis for these developments is the know-how that Fujitsu's engineering departments world wide have built up in close co-operation with Fujitsu's customers.

In Europe this expertise is organised in a business unit supporting the automotive and industrial markets.

Both markets require high quality products with state-of-the-art network interfaces such as CAN, LIN, IDB1394, and FlexRay™. The product portfolio ranges from smart and small 8-bit to high performance 32-bit RISC microcontrollers.

Fujitsu embedded flash technology has always been the basis for reliable products. The fourth generation of this technology is now available.

European Microcontroller Design Centre (EMDC)

The centre has completed about 100 development projects since its foundation in 1997. In close partnership with our European customers, innovative products have been specified and give our customers a competitive edge in global competition. Fujitsu is a leader in fully-featured CAN and LIN MCUs and the steadily growing design centre is already preparing the next product generation, which includes products with on-chip FlexRay.

Dedicated local application support team

FME's application engineering group provides solutions for our customers. They find expertise in their application area, deep knowledge of Fujitsu's products and a high level of experience with the tool environment, which Fujitsu also provides.

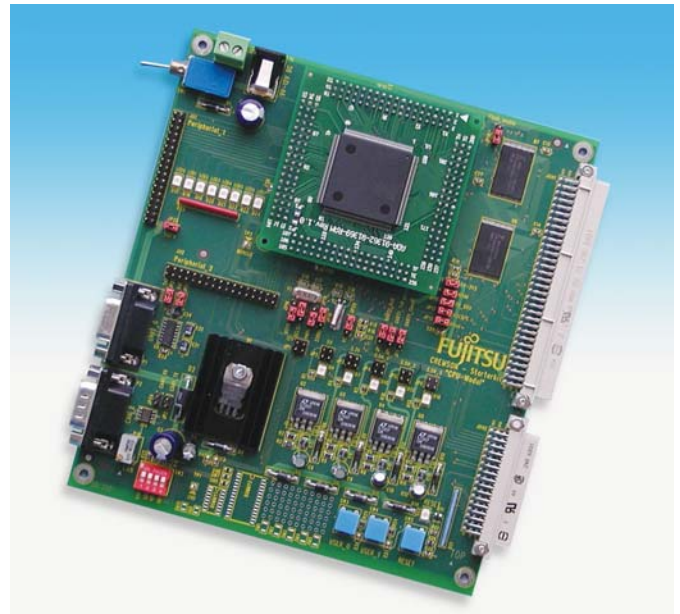

FlexRay Node, host controller (MB91F467D).

The Fujitsu Softune Workbench is the development environment for all 500 different MCUs (8- to 32-bit) and includes a state-of-the-art C-Compiler, Assembler and Debugger. It is free-of-charge in Europe. Getting started is easy with the support boards and training on offer. Application notes, software examples and EMC support complete the picture.

Quality

Formal Quality Systems like ISO9000, have been established since 1994. Products for automotive systems are certified to ISO/TS 16949. All newly developed, Fujitsu automotive MCUs are fully AEC-Q100 compliant.

Environmental Support

Fujitsu's usage of materials is fully compliant with the time plan for implementation of RoHS and WEEE programmes.

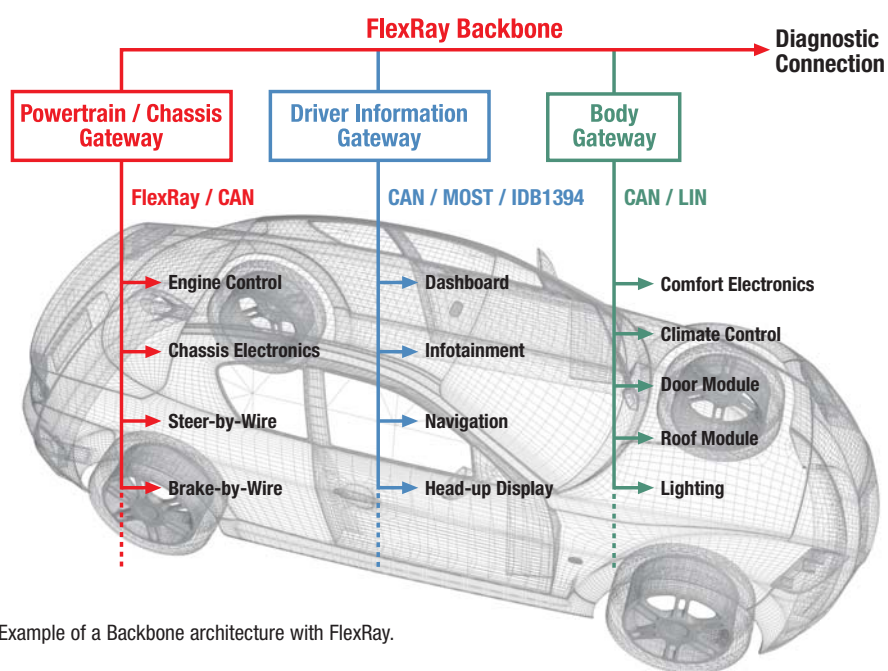

Example of a Backbone architecture with FlexRay.

More information is available at FME's MCU Web page: <http://www.fujitsu.com/emea/services/microelectronics/micros/>

Access to partners

These partners complement Fujitsu's offerings especially with regard to operating systems, driver software and development tools. Please see the 3rd party support page at http://mcu.emea.fujitsu.com/psearch_3rd_party/mcu_development_support.htm for more information.



Industrial market requires high quality products with state-of-the-art network interfaces such as CAN, LIN and IDB1394.

AUTOMOTIVE Strengths

Fujitsu's European Microcontroller Design Centre today has extensive experience gained from more than 100 automotive development projects.

This is demonstrated by a host of smart on-chip features that meet the requirements of our automotive customers. Substantial software support for Fujitsu microcontrollers is also in place.

Programmable port levels

Many CAN microcontrollers feature programmable port levels. In addition to TTL and CMOS levels, so-called 'automotive levels' (with $V_{IL} = 0.5V_{cc}$) can be selected. This is a valuable feature as ground levels in vehicles may show offsets of several volts.

Clock modulation

This feature improves electromagnetic compatibility which is becoming an ever important requirement with increasing CPU speeds.

Clock modulation reduces emission peak levels by distributing the system clock frequency over a certain frequency range. This means that sharp high peaks are converted to a wider slewed signal in the frequency spectrum – with reduced emission levels. Graph 1 shows EMI measurement without clock modulation; Graph 2 shows clock modulation switched on.

LIN USART

A powerful serial communication interface with hardware support for LIN protocol is incorporated into every new Fujitsu CAN microcontroller. This interface supports SPI mode and baud rates up to 4MBaud in USART mode.

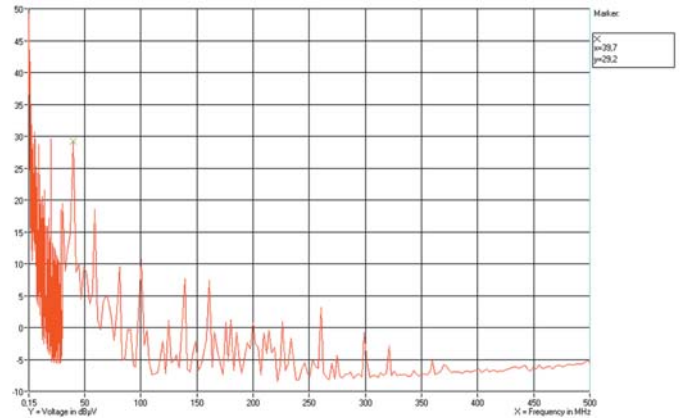

Graph 1: Emission IEC Norm 61967 part 4, MB90F394, Clock modulation=off.

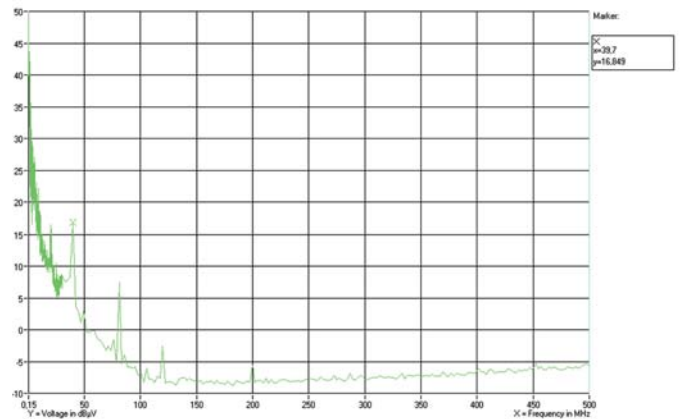

Graph 2: Emission IEC Norm 61967 part 4, MB90F394, Clock modulation=on.

New 8-bit MCU family

F²MC-8FX CPU-CORE ARCHITECTURE

- 8-bit CPU Core
 - Eight 16-bit registers
 - High speed, 62.5ns cycle time @ 16MHz CPU clock
 - Up to 32 memory mapped register banks (each bank consists of eight 8-bit registers)
 - A-T architecture
- Optimised internal bus
 - Reduced instruction cycles
 - Pipelining of the internal bus
- 64kByte linear addressing space
- Powerful arithmetic operation and transmission
 - Division instruction: 16-bit / 16-bit = 16-bit
 - Data transmission up to 16-bit
- Clock Multiplier Circuit
 - PLL x1, x2, x2.5
- Enhanced Interrupt
 - Four interrupt levels selectable for each interrupt

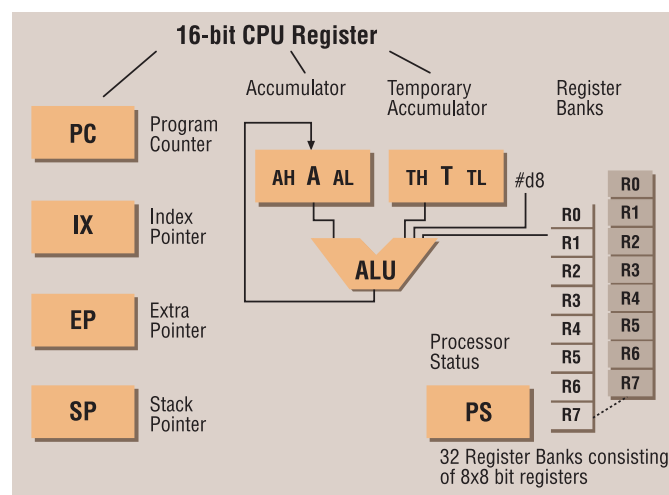

Features

- Instruction compatible with F²MC-8L (except divide/multiply instruction)
- Enhanced CPU performance (minimum instruction execution time: 100ns)
- F²MC-8FX new function (16-bit, 16-bit division instruction, 4 interrupt levels)
- Low leakage process technology (1.8V operation, 1μA supply current at watch mode)
- Dual-operation flash (MB95F100, MB95F110, MB90F120 only)
- Flash security on every device
- Hardware LIN available on every device
- Compact and low-price debug environment

New 8-bit MCU family

F²MC-8FX

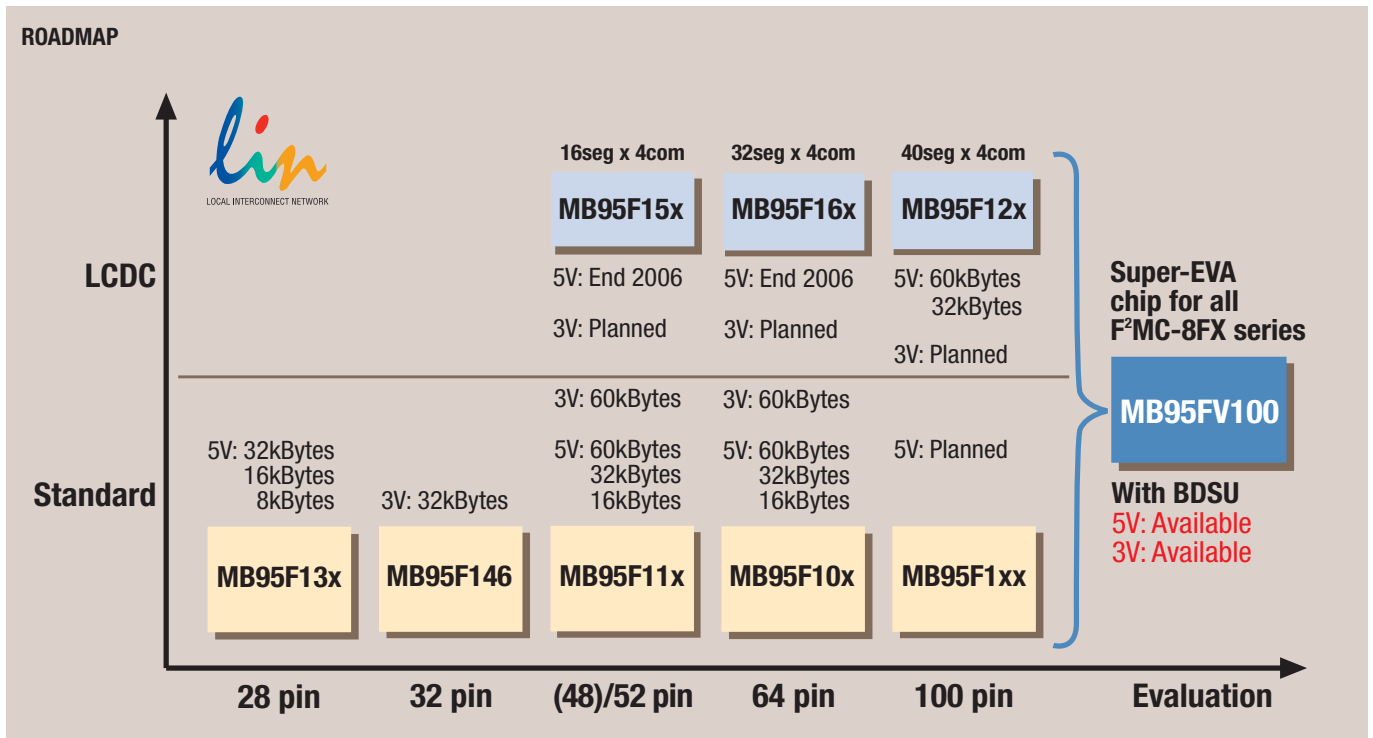

8FX product roadmap: for every series both 5V version and 3V version are planned.

Dual-operation flash:

Execute program code from one bank while writing to, or erasing another.

- No delay in program execution
- Replacement of external E²PROM with following advantages:
 - 1) Faster process (programming, erasing)
 - 2) Improved code security (manipulation prevention)
 - 3) Smaller PCB area

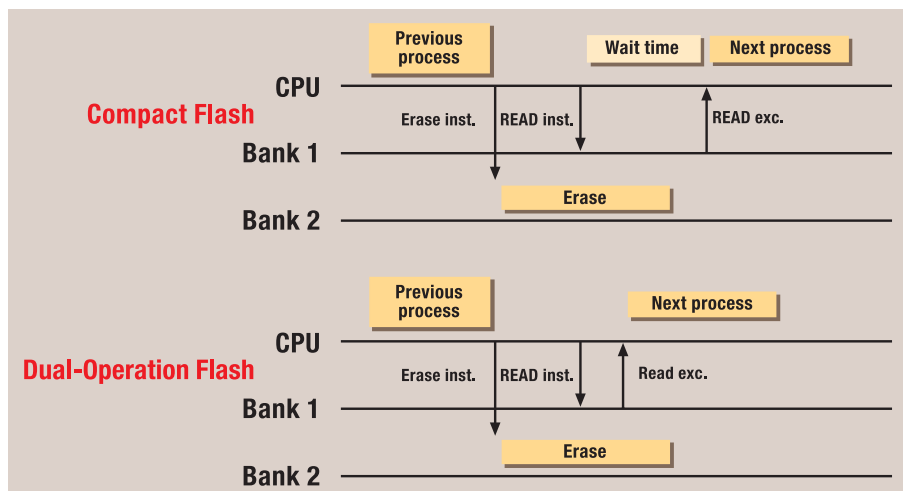

Executes program code from one bank while writing to or erasing another.

New 8-bit MCU family

F²MC-8FX

Compact and low cost 8FX development set-up

- Softune Workbench for software development
- BGM adaptor for evaluation: MB2146-09
- Evaluation board: MB2146-401
- MCU board (with evaluation chip on board): MB2146-30x

Header boards are available for evaluating directly in user system

Evaluation kit

CONCERTO-Kit with MB95F108H on board, provides the opportunity to program dual-operation flash, and test 8FX core and the peripherals at low cost and with minimal effort.

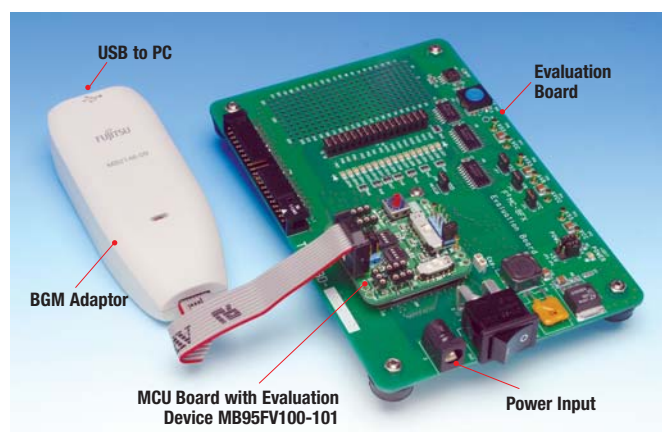

Compact and low cost 8FX development set-up.

| FEATURE OF THE BGM ADAPTOR FOR F ² MC-8FX FAMILY | |
|---|--|
| Adaptor model for debugging | MB2146-09 |
| Host interface (download time) | USB: 12Mbps (125kbps: at an operating frequency of 4MHz) |
| Execution control | Continuous execution, step execution |
| Instruction execution break | 256 points |
| Data break | 2 points |
| Emulation memory | The size equivalent to Flash ROM MB95FV100 (60kBytes) |
| Trace capacity | 16 branches |
| Sequential break | 2 levels (only code) |

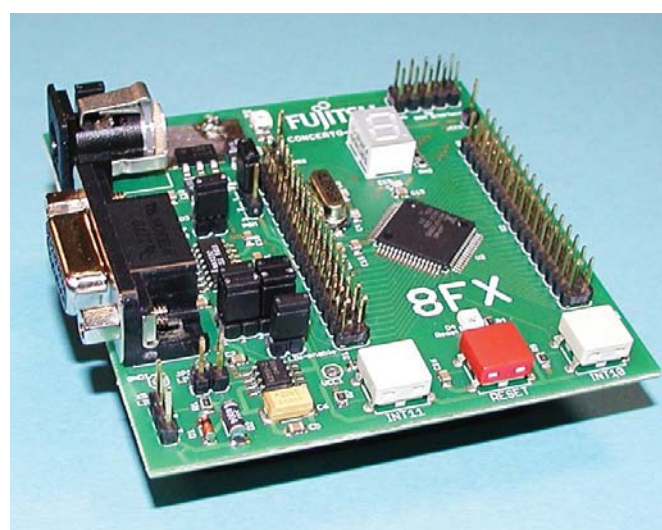

The flash device MB95F108H (5V version) mounted on the low cost evaluation board: CONCERTO board.

PRODUCT OVERVIEW
MICROCONTROLLERS

New 8-bit MCU family - **F²MC-8FX** product details

MB95110 is a series of general-purpose microcontrollers. It is available in 52-pin packages (48-pin package for 3V only) with different memory configurations to best fit application needs. The 60kBytes flash version features dual-operation flash enabling E²PROM emulation or conformable boot loaders. 16 and 32kByte versions feature segmented, single-bank flash memory.

It supports serial communication protocols like serial synchronous, serial asynchronous, SPI, LIN and I²C.

Its flexible composite timers can be used as interval timer, PWM, PWC and input capture functions. Two composite timers can be used to fully control one DC motor. In addition 2 PPGs (programmable pulse generators) are available, which can be used as 2 channel 16-bit PPG or 4 channel 8-bit PPG. In addition, a dedicated 16-bit PPG is available.

A very fast 10-bit successive approximation ADC with 8 channels, features a conversion time of only 1.2µsecs! The resources are rounded-off by 8 programmable external interrupt inputs.

Low-voltage detection with reset and clock supervisor (both only for 5V versions) eliminate the need for external watchdogs and supply-voltage supervisor ICs thus saving total system cost.

MB95160 series features the same resources as MB95110 series adding an on-chip LCD controller. LCDs with 4COM and up to 32SEG lines can be directly driven from the MCU. Functions like internal reference voltage dividers and automatic blinking ease integration of a low-cost LCD into the target application.

The flash memory is a 60kByte compact flash.

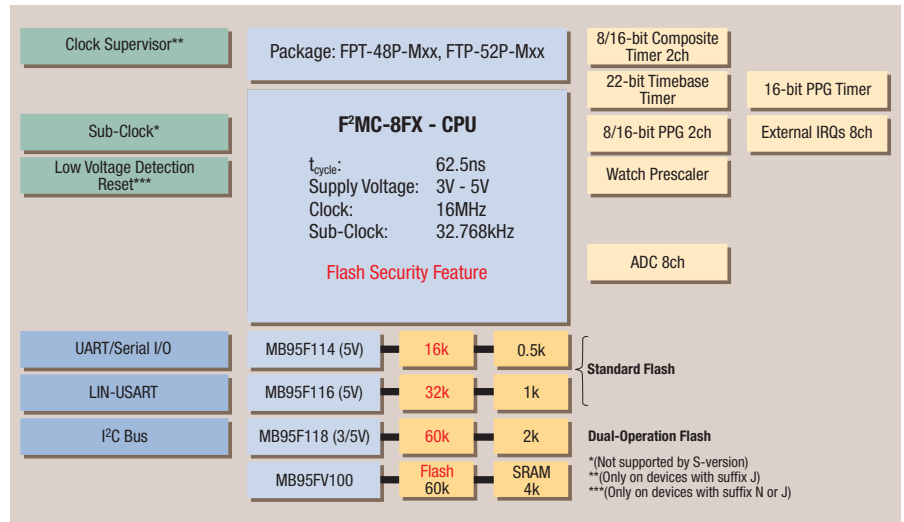

MB95110 series block diagram.

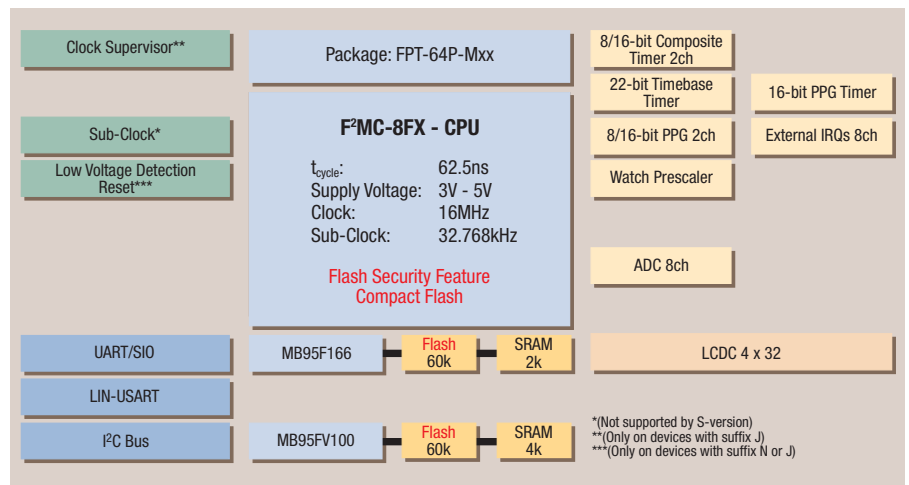

MB95160 series with LCDC block diagram.

8-bit PRODUCT LINE-UP

F²MC-8L Low Power/Low Voltage Microcontrollers

| Features Series | Part | ROM/OTP/Flash (kByte) | RAM (Byte) | Max. Clock MHz (Sub-clock) | Ports | Ext. Inter. | PWM | PWC | Timer/Counter | UART | I ² C | SIO | ADC | LCDC | Buzzer | Special Features | Power Saving Modes | Pin Count |
|-----------------|---------------|-----------------------|------------|----------------------------|-------|-------------|-----------|------------|-------------------------------------|--------|------------------|------------|-------------|--------|-----------------------|--|-------------------------------------|-----------|
| 190/A/AH | MB89191 | 4 | 128 | 4.2 | 22 | 11 | – | – | 2 x 8-bit | – | – | 1 x 8-bit | – | – | Yes | Remote Control, 9 x High Current Outputs (H version) | SLEEP STOP | 28 |
| | MB89191A | 4 | 128 | 19 | 19 | | | 1 x 16-bit | | | | 8 x 8-bit | | | | | | |
| | MB89191AH | 4 | 128 | 19 | 19 | | | | | | | 8 x 8-bit | | | | | | |
| | MB89193 | 8 | 256 | 22 | 22 | | | | | | | – | | | | | | |
| | MB89193A | 8 | 256 | 19 | 19 | | | | | | | 8 x 8-bit | | | | | | |
| | MB89193AH | 8 | 256 | 19 | 19 | | | | | | | 8 x 8-bit | | | | | | |
| | MB89195 | 16 | 256 | 22 | 22 | | | | | | | – | | | | | | |
| | MB89P195 | 16 | 256 | 22 | 22 | | | | | | | – | | | | | | |
| | MB89195A | 16 | 256 | 19 | 19 | | | | | | | 8 x 8-bit | | | | | | |
| MB89P195A | 16 | 256 | 19 | 19 | | | | | | | 8 x 8-bit | | | | | | | |
| 201 | MB89F202 | 16 | 512 | 12.5 | 27 | 4 | 1 x 8-bit | – | 2 x 8-bit or 1 x 16-bit | 1ch | – | 1 x 8-bit | 1 x 10-bit | – | – | Flash, 1 x 12-bit PPG, 21-bit timebase timer 5V | SLEEP STOP | 34 |
| 470 | MB89475 | 16 | 512 | 12.5 | 39 | 9 | 1 x 8-bit | 2 x 8-bit | 2 x 8-bit or 1 x 16-bit | 1ch | – | – | 8 x 10-bit | – | Yes | 21-bit time base timer | SLEEP STOP WATCH | 48 |
| | MB89P475 | 16 | 512 | (32kHz) | 39 | 9 | 1 x 8-bit | 2 x 8-bit | 2 x 8-bit or 1 x 16-bit | 1ch | – | – | 8 x 10-bit | – | Yes | | | |
| 480 | MB89485 | 16 | 512 | 12.5 | 42 | 12 | 1 x 8-bit | 2 x 8-bit | 2 x 8-bit or 1 x 16-bit | 1ch | – | – | 4 x 10-bit | 4 x 31 | yes | LCD with booster, 6-bit PPG | SLEEP STOP WATCH | 64 |
| | MB89P485 | 16 | 512 | (32kHz) | 42 | 12 | 1 x 8-bit | 2 x 8-bit | 2 x 8-bit or 1 x 16-bit | 1ch | – | – | 4 x 10-bit | 4 x 31 | yes | | | |
| 490 | MB89498 | 48 | 2048 | 12.5 | 66 | 16 | 2 x 8-bit | – | 4 x 8-bit or 2 x 16-bit | 1(SIO) | 1 | 1ch | 8 x 10-bit | 4 x 32 | – | 21-bit timebase timer 3V | SLEEP STOP WATCH | 100 |
| | MB89F497 | 32 | 1024 | (32kHz) | 62 | 16 | 2 x 8-bit | – | 4 x 8-bit or 2 x 16-bit | 1(SIO) | 1 | 1ch | 8 x 10-bit | 4 x 36 | – | | | |
| | MB89F499 | 60 | 2024 | | 66 | 16 | 2 x 8-bit | – | 4 x 8-bit or 2 x 16-bit | 1(SIO) | 1 | 1ch | 8 x 10-bit | 4 x 32 | – | | | |
| 530 | MB89535A | 16 | 512 | 12.5 | 53 | 12 | 2 x 8-bit | 1 x 8-bit | 1 x 16-bit | 2ch | 1 | 1 x 8-bit | 8 x 10-bit | – | – | Mask versions 2 x 12-bit + 1 x 6-bit PPG 3V & 5V(H) | SLEEP STOP WATCH | 64 |
| | MB89537C/H/HC | 32 | 1024 | (32kHz) | 53 | 12 | 2 x 8-bit | 1 x 8-bit | 1 x 16-bit | 2ch | 1 | 1 x 8-bit | 8 x 10-bit | – | – | | | |
| | MB89538C/H/HC | 48 | 2048 | | 53 | 12 | 2 x 8-bit | 1 x 8-bit | 1 x 16-bit | 2ch | 1 | 1 x 8-bit | 8 x 10-bit | – | – | | | |
| | MB89P538 | 48 | 2048 | | 53 | 12 | 2 x 8-bit | 1 x 8-bit | 1 x 16-bit | 2ch | 1 | 1 x 8-bit | 8 x 10-bit | – | – | | | |
| MB89F538 | 48 | 2048 | | 52 | 12 | 2 x 8-bit | 1 x 8-bit | 1 x 16-bit | 2ch | 1 | 1 x 8-bit | 8 x 10-bit | – | – | Flash, 2ch 12-bit PPG | | | |
| 560/C/H/HC | MB89567C/H/HC | 32 | 1024 | 10 | 50 | 12 | 2 x 8-bit | 1 x 8-bit | 2 x 8-bit or 1 x 16-bit | 2ch | 1 | 1 x 8-bit | 8 x 10-bit | 4 x 24 | – | 1 x 6-bit PPG 1 x 12-bit PPG Remote Control 3V & 5V(H) mask versions | SLEEP STOP WATCH | 80 |
| | MB89P568 | 48 | 1024 | (32kHz) | 50 | 12 | 2 x 8-bit | 1 x 8-bit | 2 x 8-bit or 1 x 16-bit | 2ch | 1 | 1 x 8-bit | 8 x 10-bit | 4 x 24 | – | | | |
| 570 | MB89577 | 32 | 3k | 10 | 82 | 4 | – | – | 2 x 8-bit, 1 x 16-bit or 2 x 16-bit | 1ch | 1 | (SIO) | 12 x 10-bit | 4 x 14 | – | Bridge Circuit, D/A 2-ch, Comparator, 21-bit Timebase Timer | SUB-CLOCK SLEEP STOP WATCH | 100 |
| | MB89P579A | 60 | 3k | (32kHz) | 82 | 4 | – | – | 2 x 8-bit, 1 x 16-bit or 2 x 16-bit | 1ch | 1 | (SIO) | 12 x 10-bit | 4 x 14 | – | | | |
| 580B/BW | MB89583B/BW | 8 | 512 | 6 | 53 | 8 | 2 x 8-bit | – | – | 1ch | – | – | – | – | – | USB I/F rev 1.0 low and full speed, PLL, 21-bit Time-base Timer, 'BW' :outputs at low level until USB connection takes place | SLEEP STOP | 64 |
| | MB89585B/BW | 16 | 1024 | | 53 | 8 | 2 x 8-bit | – | – | 1ch | – | – | – | – | – | | | |
| | MB89P585B/BW | 16 | 1024 | | 53 | 8 | 2 x 8-bit | – | – | 1ch | – | – | – | – | – | | | |
| 930 | MB89935B | 16 | 512 | 10 | 21 | 11 | 1 x 8-bit | – | 1 x 8-bit | 1ch | – | – | 8 x 10-bit | – | – | Input Capture 1-ch, 12-bit Programmable Pulse Generator | SLEEP STOP | 30 |
| | MB89P935B | 16 | 512 | | 21 | 11 | 1 x 8-bit | – | 1 x 8-bit | 1ch | – | – | 8 x 10-bit | – | – | | | |

Notes: • MB89Pxxx signifies OTP device • MB89Txxx signifies ROMless device • MB89Fxxx signifies flash device • All series feature a built-in Watchdog timer.

PRODUCT OVERVIEW MICROCONTROLLERS

8-bit PRODUCT LINE-UP

8-bit MC-8FX Low Power/High Performance Microcontrollers

| Features Series MB95xxx | Part | ROM/Flash (kByte) | RAM (Byte) | Power Supply Voltage | Max. Clock MHz (Sub-clock option) | Max Ports | Ext. Inter. | PWM Functions | Timer Functions | 16-bit Reload Timer | LIN-UART | UART/SIO | FC | ADC | LCDC | Special Features | Power Saving Mode | Pin Count | |
|-------------------------|-------------------------|-------------------|------------|----------------------|-----------------------------------|-----------|-------------|--|---|---------------------|----------|----------|----|-------------|--------|---|---------------------------------|-----------|--|
| 100B | MB95F108B | 60 | 2k | 1.8-3.3V | 16 | 55 | 12 | 6 | 9 | 1 | 1 | 1 | 1 | 12 x 10-bit | No | Dual-Operation Flash (60kBytes version only) SPI, Watch timer | SLEEP STOP WATCH TIMER | 64 | |
| | MB95107B (S/W) | 48 | 2k | 1.8-3.6V | (32kHz) | | | (2ch x 16-bit, 2ch x 8-bit PPG, 2ch composite timer) | (2ch composite timer*, 6 PPG timers, 16-bit reload timer) | | | | | | | | | | |
| 100AM | MB95F104A | 16 | 512 | 2.3-5.5V | 16 | 54 | 12 | 6 | 9 | 1 | 1 | 1 | 1 | 12 x 10-bit | No | Low-Voltage-Detection, Dual-Operation Flash (60kBytes version only) SPI, Watch timer | SLEEP STOP WATCH TIMER | 64 | |
| | MB95F106A | 32 | 1k | 2.3-5.5V | (32kHz) | | | (2ch x 16-bit, 2ch x 8-bit PPG, 2ch composite timer) | (2ch composite timer*, 6 PPG timers, 16-bit reload timer) | | | | | | | | | | |
| | MB95F108A | 60 | 2k | 2.3-5.5V | | | | | | | | | | | | | | | |
| | MB95106AM (M/N/J) (S/W) | 60 | 2k | 2.3-5.5V | | | | | | | | | | | | | | | |
| 110B | MB95F118B | 60 | 2k | 1.8-3.3V | 16 | 39 | 8 | 5 | 7 | No | 1 | 1 | 1 | 8 x 10-bit | No | Dual-Operation Flash (60kBytes version only) SPI, Watch timer | SLEEP STOP WATCH TIMER | 48, 52 | |
| | MB95116B (S/W) | 32 | 1k | | (32kHz) | | | (1ch x 16-bit, 2ch x 8-bit PPG, 2ch composite timer) | (2ch composite timer*, 5 PPG timers) | | | | | | | | | | |
| 110M | MB95F114 | 16 | 512 | 2.3-5.5V | 16 | 39 | 8 | 5 | 7 | No | 1 | 1 | 1 | 8 x 10-bit | No | Low-Voltage-Detection, Dual-Operation Flash (60kBytes version only) SPI, Watch timer | SLEEP STOP WATCH TIMER | 52 | |
| | MB95F116 | 32 | 1k | 2.3-5.5V | (32kHz) | | | (1ch x 16-bit, 2ch x 8-bit PPG, 2ch composite timer) | (2ch composite timer*, 5 PPG timers) | | | | | | | | | | |
| | MB95F118 | 60 | 2k | 2.3-5.5V | | | | | | | | | | | | | | | |
| | MB95117M (M/N/J) (S/W) | 48 | 2k | 2.3-5.5V | | | | | | | | | | | | | | | |
| 120 | MB95F128W (D/E) | 60 | 2k | 1.8-3.3V 1.8-3.3V | 16 (32kHz) | 87 | 12 | 6 | 9 | 1 | 1 | 1 | 1 | 12 x 10-bit | 4 x 40 | Dual-Operation Flash (60kBytes version only) SPI, Watch timer | SLEEP STOP WATCH TIMER | 100 | |
| 120MB | MB95F124B | 16 | 512 | 2.3-5.5V | 16 | 87 | 12 | 6 | 9 | 1 | 1 | 1 | No | 12 x 10-bit | 4 x 40 | Low-Voltage-Detection, Dual-Operation Flash (60kBytes version only) SPI, Watch timer | SLEEP STOP WATCH TIMER | 100 | |
| | MB95F126B | 32 | 1k | 2.3-5.5V | (32kHz) | | | (2ch x 16-bit, 2ch x 8-bit PPG, 2ch composite timer) | (2ch composite timer*, 6 PPG timers, 16-bit reload timer) | | | | | | | | | | |
| | MB95F128B | 60 | 2k | 2.3-5.5V | | | | | | | | | | | | | | | |
| | MB95128M (M/N/J) (S/W) | 60 | 2k | 2.3-5.5V | | | | | | | | | | | | | | | |
| 130M | MB95F133 | 8 | 256 | 2.3-5.5V | 16 | 20 | 8 | 3 | 4 | No | 1 | 1 | No | 8 x 10-bit | No | Low-Voltage-Detection, SPI, Watch timer | SLEEP STOP WATCH TIMER | 28 | |
| | MB95F134 | 16 | 512 | 2.3-5.5V | (32kHz) | | | (1ch x 16-bit, 1ch x 8-bit PPG, 1ch composite timer) | (1ch composite timer*, 3 PPG timers) | | | | | | | | | | |
| | MB95F136J | 32 | 1k | 2.3-5.5V | | | | | | | | | | | | | | | |
| | MB95136M (M/N/J) (S/W) | 32 | 1k | 2.3-5.5V | | | | | | | | | | | | | | | |
| 140 | MB95F146 (S/W) | 32 | 1k | 1.8-3.3V | 16 | 24 | 8 | 3 | 5 | No | 1 | 1 | No | 8 x 10-bit | No | Low-Voltage-Detection, SPI, Watch timer | SLEEP STOP WATCH TIMER | 32 | |
| 150 | MB95F156W | 32 | 1k | 2.3-5.5V | 16 | 39 | 8 | 5 | 7 | No | 1 | 1 | No | 8 x 10-bit | 4 x 16 | Low-Voltage-Detection, SPI, Watch timer | SLEEP STOP WATCH TIMER | 48 | |
| | MB95156M (M/N/J) | 32 | 1k | 2.3-5.5V | (32kHz) | | | (1ch x 16-bit, 2ch x 8-bit PPG, 2ch composite timer) | (2ch composite timer*, 5 PPG timers) | | | | | | | | | | |
| 160 | MB95F166W (D/E) | 32 | 1k | 1.8-3.3V | 16 | 53 | 8 | 5 | 7 | No | 1 | 1 | 1 | 8 x 10-bit | 4 x 32 | Low-Voltage-Detection, SPI, Watch timer | SLEEP STOP WATCH TIMER | 64 | |
| 160M | MB95F168W | 60 | 2k | 2.3-5.5V | 16 | 53 | 8 | 5 | 7 | No | 1 | 1 | 1 | 8 x 10-bit | 4 x 32 | Low-Voltage-Detection, SPI, Watch timer | SLEEP STOP WATCH TIMER | 64 | |
| | MB95168M (M/N/J) | 60 | 2k | 2.3-5.5V | (32kHz) | | | (1ch x 16-bit, 2ch x 8-bit PPG, 2ch composite timer) | (2ch composite timer*, 5 PPG timers) | | | | | | | | | | |

Notes:

- S Single clock
- W Dual clock
- M Without LVD (low voltage detector) and CSV (clock supervisor)
- N With LVD, without CSV
- J With LVD/CSV
- D With LCD voltage booster
- E Without LCD voltage booster

* Composite timer can be used as 2ch x 8-bit timer or 1ch x 16-bit timer or built-in timer function, PWC function, PWM function, capture function and square waveform output.

F²MC-16 CPU-CORE ARCHITECTURE

One obvious strength of this 16-bit architecture is its excellent code efficiency. As Fujitsu has a long record in Compiler business, dating back to the early days of mainframe computers, it was a logical move not only to equip the 16LX architecture with an instruction set that is C-code optimised but also to supply the actual C-compiler which draws on this architectural strength - for example flexible addressing options. Bank registers for program code and data allow the use of 16-bit addresses - thus reducing code size while at the same time increasing processing performance.

Alternatively, several memory models exist, allowing linear addressing over the complete memory range.

As the die size of MCUs mainly depends on memory resources, it is obvious that fitting more lines of C-code into the same physical memory, saves cost.

This is particularly easy with 16-bit instruction sets. 32-bit instruction sets in general produce less efficient code resulting in larger chips and more cost.

The new 16FX products inherit the 16LX instruction set and use the same C-compiler, which allow them to achieve the same efficiency in memory utilisation.

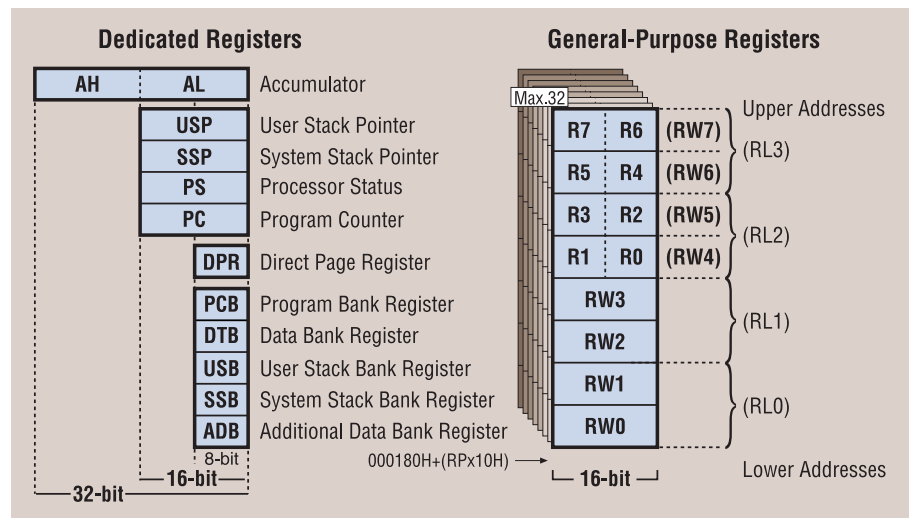

16-bit CPU-core programming model.

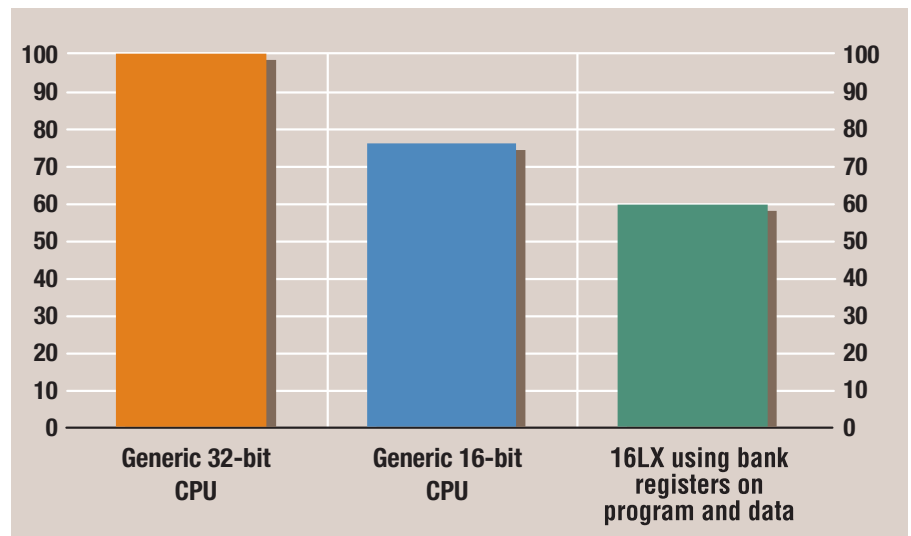

Graph shows memory use (kB) for example program written in C.

The new 16-bit MCU family: **F²MC-16FX**

Fujitsu is introducing the next generation of 16-bit MCU, 16FX series.

Fast

16FX series is based on an improved CPU with significantly increased internal Bus bandwidth. As a result, program execution is accelerated, as can be seen in the Dhrystone benchmark (Dhrystone 2.1 compared to MB90340 series). 16FX is about 3 times faster (depending on the memory model used) than 16LX at the same clock frequency. For example at 24MHz 16FX achieves more than 11 real MIPS (Dhrystone 2.1). The architecture improvement is particularly visible when handling large data structures (see memory model 'Large' in graph 1).

But that's not all. New technology and improved design allow for CPU frequencies up to 56MHz - thus achieving processing performance ranges of 32-bit processors.

Efficient

16FX combines the advantages of 16- and 32-bit architectures. The C-code efficiency benefits from the 16-bit instruction set. Instruction Pipelining, a technique widely used in the 32-bit RISC, world allows 16FX to reach RISC-like performance. With instructions completed in less clock cycles, the same performance is achieved with less power consumption (compared to architectures without pipelining).

The 16-bit bus width again is an advantage for a low power consumption result compared to 32-bit architectures. A 32-bit bus will have a higher capacitance which increases current consumption particularly at high frequencies. The use of latest CMOS technology also translates into efficient use of silicon space (smaller chip) and lower power consumption.

16FX specific power reduction features include a reduced internal CPU supply voltage, peripheral clock speed selectable independently from CPU speed, and reduced number of clocks per instruction (CPI). The result is an 80% reduction in power consumption compared to 16LX at the same performance.

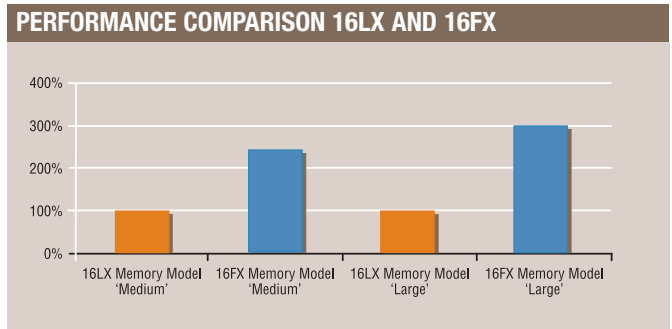

Graph 1 shows the performance ratio (Dhrystone 2.1) of 16FX compared to 16LX at 24MHz CPU frequency for different memory models. 16LX = 100%.

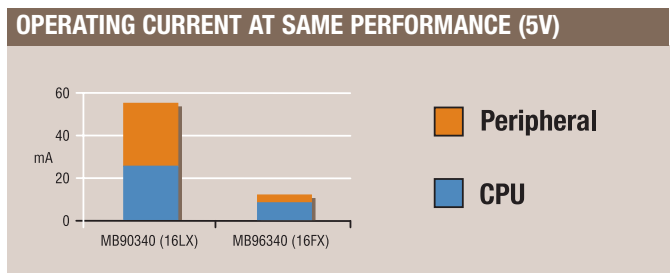

Graph 2 compares 16FX operating current simulation result to 16LX typical values, both operating at 4MIPS (Dhrystone 2.1) performance. 16FX achieves the performance at lower frequency with only 22% of the power consumption.

16LX compatible

The 16FX CPU uses all 16LX machine instructions. With the same instruction set, the Assembler and C-compiler are also unchanged when switching from LX to FX CPU. Quite a few of the 16LX peripherals can be found again on 16FX - making software conversion from LX to FX an easy task. On the hardware side it is even easier. The first 16FX product is fully pin-compatible to the successful MB90340 (16LX) series. No need for a PCB change. You can even use the same Fujitsu Starter Kit (Flash-CAN-100P-340).

Features of **16-BIT FAMILIES**

F^{MC}-16LX device features

- Mask ROM and flash
- Up to 24MHz (42ns) maximum internal clock speed from external 4MHz
- On-chip PLL multiplies the external clock speed. PLL factor can be selected by software
- Optimised instruction set for controller applications
 - bit, Byte, word, long word data types
 - 23 addressing modes
 - variety of pointers
- Signed multiply instruction 16-bit x 16-bit
- Signed divide instruction 32-bit / 16-bit
- 18-bit Time-base timer
- 15-bit Watch timer, (devices with 32kHz sub-clock only)
- Watch-dog timer
- Fast interrupt processing
- Powerful interrupt functions – 8 programmable priority levels, more than 30 possible hardware vectors and more than 200 software vectors
- Program Patch function
 - facility to ‘patch over’ mask programmed code with update from external memory
 - hardware breakpoints to support remote system debugging with a monitor debugger
- Power saving modes
 - 7 for single clock or 10 for dual clock
 - sleep, stop, CPU intermittent, hardware standby ...

F^{MC}-16FX device features

- 20 Dhrystone MIPS computing performance (V2.1)
- On-chip oscillators for short start-up, clock supervisor function, sub-clock or main clock operation
- Start-up time <1ms to RC run mode, <8ms to PLL run mode
- Operating voltage range 3.0-5.5V
- Internal CPU voltage reduced to 1.8V (less current consumption, less EM emissions)
- New energy-saving options: separate clock dividers for core and peripherals
- DMA: several channels that can be assigned to any peripheral resource
 - One Byte per clock cycle transfer speed
- Embedded Debugging: firmware support for debugging via USART (no need to link a monitor kernel to application software)
- Low voltage detection reset: available on all 16FX devices
- Interrupt: every resource has its own interrupt. A table base register allows relocating the base address of the interrupt vector table

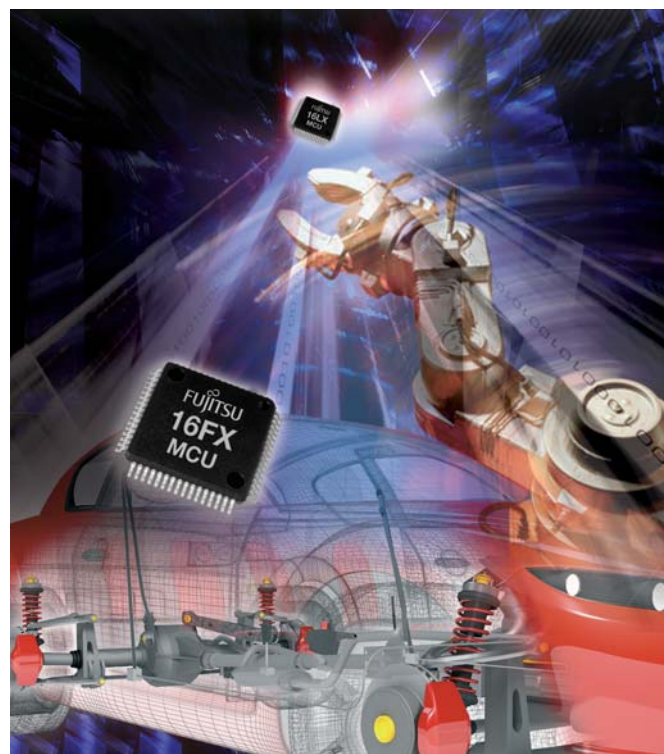

Next generation 16FX microcontroller delivers 5x the computing power, 78% less power consumption and is pin compatible with its proven predecessor - the 16LX.

- Ports: up to 4 different input levels selectable by software ‘port input enable’ function allows pins to be left open (no termination by resistor required)
- CAN: each channel offers 32 message buffers. Bosch C-CAN.
- PWM generation: improved programmable pulse generators offer more channels at full 16-bit resolution. Duty cycle and frequency are controlled in separate registers.

PRODUCT OVERVIEW MICROCONTROLLERS

F²MC-16LX PRODUCT LINE-UP

Overview of 16LX Families

| Series | Device Part Number | Group Features | RAM | Flash/Mask (ROM) | Flash Code Security | Max. Frequency (MHz) | Sub-clock | Operating Voltage | Operating Temp | Package | Max. I/Os | Watchdog | CAN interface | CAN Message Buffers/channel | UART Standard | USART LIN | SIO |
|---------------|---|--|-------------------------------|--|---------------------|----------------------|--------------------|--|----------------|----------|-----------------------|----------|-----------------------|-----------------------------|---------------|-----------|-----|
| MB90330 | MB90F334 | USB with Min-Host function | 24k | 384k | No | 24 | Yes | 3.0V to 3.6V | -40 to +85°C | QFP-120 | 94 | Yes | No | No | 4 | No | 1 |
| MB90335 | MB90F337 | USB with Min-Host function | 4k | 64k | No | 24 | Yes | 3.0V to 3.6V | -40 to +85°C | QFP-64 | 45 | Yes | No | No | 2 | No | 1 |
| MB90340 | MB90(F)347CE(S) MB90(F)349CE(S) MB90(F)342CE(S) MB90(F)345CE(S) | 'S': version for single clock (with two additional I/O ports) 'C' version with I ² C bus and 24ch ADC | 6k 15.75k 15.75k 20k | 128k 256k 256k 512k | Yes | 24 | not for S versions | 3.5 to 5.5V* | -40 to 105°C | QFP-100 | 80 (82 for S version) | Yes | 1 1 2 2 | 16 | No | 4 | No |
| MB90350 | MB90(F)351/E/TE(S) MB90(F)352/E/TE(S) | Subset of MB90340 'T': low voltage detection | 4k | 64k 128k | No Yes | 24 | not for S versions | 3.5 to 5.5V* | -40 to 105°C | QFP-64 | 49 (51 for S version) | Yes | 1 | 16 | No | 2 | No |
| MB90360 | MB90F362/E/TE(S)*** | Subset of MB90350 'T': low voltage detection | 3k | 64k | Yes | 24 | not for S | 3.5 to 5.5V | -40 to 105°C | QFP-48 | 34 (36 for S version) | Yes | 1 | 16 | No | 2 | No |
| MB90385/S | MB90F387/S MB90387/S | Pin compatible to Dual Operation Flash MB90895 | 2k 2k | 64k 64k | No | 16 | not for S versions | 3.5 to 5.5V* | -40 to 105°C | LQFP-48 | 34 (36 for S version) | Yes | 1 | 8 | 1 | No | No |
| MB90390 | MB90F394HA MB90F395HA MB90394HA | 6 x stepper motor PWM, sound generator, RTC clock timer | 10k 30k 10k | 384k 512k 384k | No | 20 24 | No | 3.5 to 5.5V* | -40 to 85°C | LQFP-120 | 96 | Yes | 2 | 16 | 2 | 1 | 1 |
| MB90420G/425G | MB90F428GA/GB/GC MB90428GA/GB/GC MB90427GA/GB/GC MB90F423GA/GB/GC MB90423GA/GB/GC | 'A': single clock, CPU operating detect unit. 'B': dual clock, CPU operation detect unit. 'C': dual clock | 6k 6k 4k 6k 6k | 128k 128k 64k 128k 128k | No | 16 | not for A versions | 3.7V to 5.5V* 3.0 to 5.5V for C version | -40 to 105°C | QFP-100 | 58 | Yes | 1 1 1 2 2 | 16 | 2 | No | No |
| MB90435 | MB90F437 L/Ls MB90438 L/Ls MB90439 L/Ls MB90F438 L/Ls MB90F439 L/Ls | Pin compatible to MB90540/545 series | 2k 4k 6k 4k 6k | 64k 128k 256k 128k 256k | Yes | 16 | not on S-version | 4.5V to 5.5V | -40 to +105°C | QFP-100 | 81 | Yes | No | No | 2 | No | 1 |
| MB90455 | MB90F455 /S MB90F456 /S MB90F457 /S MB90455 /S MB90456 /S MB90457 /S | Pin compatible to MB90385 series | 2k 2k 2k 2k 2k | 24k 32k 64k 24k 32k 64k | No | 16 | not on S-version | 4.5V to 5.5V | -40 to +105°C | QFP-48 | 34 (36 for S-version) | Yes | No | No | 1 | No | 1 |
| MB90460 | MB90F462A MB90462A | Inverter PWM for 2 Motors (AC/DC) | 2k 2k | 64k 64k | Yes | 16 | No | 4.5V to 5.5V | -40 to +85°C | QFP-64 | 50 | Yes | No | No | 2 | No | No |
| MB90480 | MB90F481 MB90F482 | 3V supply, 2 x 8-bit Up/Down counter | 4k 6k | 192k 256k | No | 25 | Yes | 2.7V to 3.6V | -40 to +85°C | QFP-100 | 84 | Yes | No | No | 1 | No | 2 |
| MB90560 | MB90F562B MB90561 MB90562 | 3ch PPG for AC or DC motor control | 2k 1k 2k | 64k 32k 64k | Yes | 16 | No | 4.5V to 5.5V | -40 to +85°C | QFP-64 | 51 | Yes | No | No | 1 | No | No |

Note: * supply voltage 4.5V - 5.5V if AD converter is used • ** watch mode only for devices with sub-clock • Part numbers with prefix F are flash versions • Part numbers without prefix F are mask ROM versions • ***under development.

| ADC | PPG | OCU | ICU | 16-bit I/O Timer | Pulse Width Counter | 16-bit Reload Timer | Timebase Timer | Watch Timer | External Bus | Stepper Motor Interface | External Interrupts Drivers | I ² C Channel | Sound Generator | LCD Interface | Power Saving Modes | Evaluation Board |
|----------------|--|-----|-----|------------------|---------------------|---------------------|----------------|------------------|--------------|-------------------------|-----------------------------|--------------------------|-----------------|---------------|-----------------------------|----------------------|
| 10-bit 16ch | 3 x 16-bit / 6 x 8-bit | 4 | 4 | 1 | 1 x 16-bit | 3 | Yes | 1 | Yes (1MB) | No | 8 | 3 | No | No | Sleep, Stop, Timer, Watch | MB2031-01 +MB2031-20 |
| No | 2 x 16-bit / 4 x 8-bit | 4 | 4 | 1 | 1 x 16-bit | 3 | Yes | 1 | No | No | 8 | 1 | No | No | Sleep, Stop, Timer, Watch | TBD |
| 10-bit 16/24ch | 8 x 16-bit / 16 x 8-bit | 8 | 8 | 2 | No | 4 | Yes | Not on S version | Yes | No | 16 | 2 | No | No | Sleep, stop, timer, watch | FLASH-CAN-100P-340 |
| 10-bit 15ch | 6 x 16-bit / 12 x 8-bit | 4 | 6 | 2 | No | 4 | Yes | Not on S version | Yes | No | 8 | 1 | No | No | Sleep, stop, timer, watch | FLASH-CAN-64P-350 |
| 10-bit 16ch | 2 x 16-bit / 4 x 8-bit | No | 4 | 1 | No | 2 | Yes | Not on S version | No | No | 8 | No | No | No | Sleep, stop, timer, watch** | FLASH-CAN-48P-M26 |
| 10-bit 8ch | 2 x 16-bit / 4 x 8-bit | No | 4 | 1 | No | 2 | Yes | Not on S version | No | No | 4 | No | No | No | Sleep, stop, timer, watch | FLASH-CAN-48P-M26 |
| 10-bit 8ch | 6 x 16-bit / 12 x 8-bit only 6 connected to I/Os | 8 | 6 | 2 | No | 2 | Yes | No | No | 6ch | 8 | 1 (MB90F395) | Yes | No | Sleep, stop, timer | FLASH-CAN-120-390 |
| 10-bit 8ch | 3 x 16-bit / 6 x 8-bit only 3 connected to I/Os | No | 4 | 1 | No | 2 | Yes | Not on A version | No | 4ch | 8 | No | Yes | 4 x 24 | Sleep, stop, timer, watch | FLASH-CAN-100P-M06 |
| 10-bit 8ch | 4 x 16-bit / 8 x 8-bit 4 connected to pins | 4/2 | 6/8 | 1 | No | 2 | Yes | not on S-version | Yes | No | 8 | No | No | No | Sleep, Stop, Timer, Watch** | FLASH-CAN-100P-M06 |
| 10-bit 8ch | 2 x 16-bit / 4 x 8-bit | 0 | 4 | 1 | No | 2 | Yes | not on S-version | No | No | 4 | No | No | No | Sleep, Stop, Timer, Watch** | FLASH-CAN-48P-M26 |
| 10-bit 8ch | 3 x 16-bit / 6 x 8-bit | 6 | 4 | 1 | 2 x 16-bit | 2 | Yes | No | No | No | 8 | No | No | No | Sleep, Stop, Timer, Watch | FLASH-CAN-64P-M09 |
| 10-bit 8ch | 3 x 16-bit / 6 x 8-bit | 6 | 2 | 1 | No | 1 | Yes | Yes | Yes | No | 8 | 1 | No | No | Sleep, Stop, Timer, Watch | FLASH-CAN-100P-M06 |
| 10-bit 8ch | 3 x 16-bit / 6 x 8-bit | 6 | 4 | 1 | No | 2 | Yes | No | No | No | 8 | No | No | No | Sleep, Stop, Timer, Watch | FLASH-CAN-64P-M09 |

| ADC | PPG | OCU | ICU | 16-bit I/O Timer | Pulse Width Counter | 16-bit Reload Timer | Timebase Timer | Watch Timer | External Bus | Stepper Motor Interface | External Interrupts Drivers | PC Channel | Sound Generator | LCD Interface | Power Saving Modes | Evaluation Board |
|-------------|---|-----|-----|------------------|---------------------|---------------------|----------------|------------------|--------------|-------------------------|-----------------------------|------------|-----------------|---------------|---------------------------|-------------------------|
| 10-bit 8ch | 3 x 16-bit / 6 x 8-bit | 6 | 4 | 1 | No | 2 | Yes | No | No | No | 8 | No | No | No | Sleep, Stop, Timer, Watch | FLASH-CAN-64P-M09 |
| 10-bit 8ch | 1 x 16-bit / 2 x 8-bit | 2 | 4 | 1 | 1 | 3 | Yes | C-version | yes | No | 8 | No | No | No | Sleep, Stop, Timer, Watch | FLASH-CAN-100P-M06 |
| 10-bit 12ch | 2 x 16-bit / 4 x 8-bit, 2 connected to pins | 2 | 2 | 1 | No | 3 | Yes | No Yes | No | No | 4 | 1 | No | 4 x 48 | Sleep, Stop, Timer, Watch | FLASH-CAN-100P-340 |
| 10-bit 16ch | 4 x 16-bit | 6 | 4 | 1 | 2 | 2 | Yes | No | No | No | 8 | No | No | No | Sleep, Stop, Timer, Watch | SK-90820-80PO PFM-562-A |
| 10-bit 24ch | 8 x 16-bit / 16 x 8-bit | 8 | 8 | 2 | No | 4 | Yes | not on S-version | Yes | No | 16 | 2 | No | No | Sleep, Stop, Timer, Watch | FLASH-CAN-100P-340 |
| 10-bit 8ch | 2 x 16-bit / 4 x 8-bit | 0 | 4 | 1 | No | 2 | Yes | not on S-Version | No | No | 8 | No | No | No | Sleep, Stop, Timer, Watch | FLASH-CAN-48P-M26 |
| 10-bit 15ch | 6 x 16-bit / 12 x 8-bit | 4 | 6 | 2 | No | 1 | 1 | No | No | No | 8 | 1 | No | No | Sleep, Stop, Timer, Watch | FLASH-CAN-100P-340 |

| DMA | ADC | PPG | OCU | ICU | 16-bit I/O Timer | 16-bit Reload Timer | Timebase Timer | Sub-clock Timer | External Bus Interface | Stepper Motor Drivers | External Interrupts | PC Channel | Sound Generator | LCD Interface | Evaluation Board |
|-----|-------------|-------------|-----|-----|------------------|---------------------|----------------|---|------------------------|-----------------------|---------------------|------------|-----------------|---------------|---------------------------|
| 4 | 10-bit 18ch | 16-bit 19ch | 5 | 12 | 4 | 4 | Yes | No | Yes | No | 15 | 1 | No | No | TBD |
| 6 | 10-bit 24ch | 16-bit 16ch | 8 | 8 | 2 | 4 | Yes | No Yes No Yes No Yes No Yes No Yes No Yes No Yes | Yes | No | 16 | 2 | No | No | Flash-CAN-100P-340 (V1.2) |
| 4 | 10-bit 15ch | 16-bit 12ch | 4 | 6 | 2 | 4 | Yes | No Yes | Yes | No | 13 | 1 | No | No | Flash-CAN-64P-350 |
| 7 | 10-bit 16ch | 16-bit 8ch | 4 | 8 | 2 | 4 | Yes | No Yes No Yes | Yes | 5 | 8 | 1 | 2 | 4 x 65 | SK-96380-120PMT |

EMBEDDED FLASH Technology

All of the F²MC-16 series are supported by at least one device that has flash ROM as the user programmable memory.

Features

- Blocks divided into separately erasable sectors
- Erase protection by sector capability
- Supports programming by on-chip firmware Embedded Algorithm™
- No second programming voltage required
- 10,000 erase cycles
- 20-year data retention
- Programming by 3 methods:
 - On ordinary programmer with adaptor as with traditional OTP devices
 - Using Fujitsu embedded serial programming mode via on-chip UART/SIO directly to the flash ROM
 - Copying or downloading to flash using customer's own bootstrap software
 - Programming via CAN possible
 - 'Flash Security' read-out protection available on most flash devices

Microcontrollers with **CAN BUS CONTROLLER**

Fujitsu has a unique portfolio of 16-bit devices available offering a full featured CAN bus protocol controller as an on-chip peripheral for automotive and industrial applications. The details of these parts are listed in the tables listing the device features.

16-bit CAN BUS MICROCONTROLLERS (100-PIN)

MB90340

The MB90340 series offers a scalable family concept approach to CAN applications such as automotive body control, comfort applications and infotainment. The series features different RAM/ ROM sizes and different mixtures of peripherals allowing for easy migration to other MCUs in this series, which saves development time and costs.

LIN support, I²C bus interface, 24 analogue input channels, external bus interface, selectable port levels for CMOS, TTL and automotive levels are some of the enhanced features of this series. Options for CAN range are from CANless devices to 2ch CAN.

A security feature is incorporated, preventing unauthorised reading of the contents of the flash memory.

Features

- Fujitsu F²MC-16LX microcontroller architecture
- Max. 24MHz CPU clock
- Flash security function
- Full CAN 2.0A/2.0B interface with flexible buffering
- External bus interface
- LIN-USART 4ch (offering SPI mode)
- I²C 2ch
- External interrupts 8ch
- A/D converter 10-bit x 24ch
- Input capture 16-bit x 8ch
- Output compare 16-bit x 8ch
- Reload timers 16-bit x 4ch
- Programmable pulse generator 16-bit x 8ch or 8-bit x 16ch
- QFP 100 package
- -40 to +105°C standard temperature range

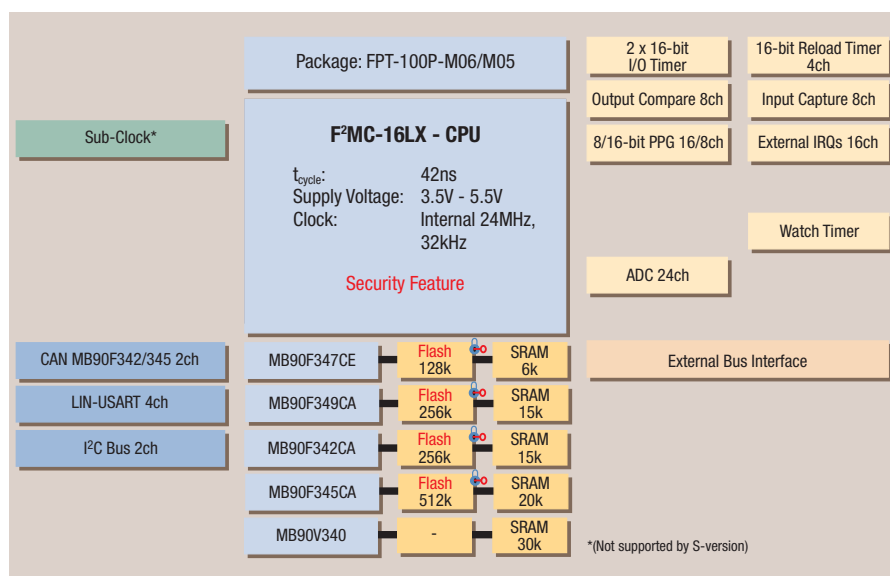

Shows the MB90340 series with LIN-USART I²C-bus, 24AD-channels, external bus and full CAN performance.

| Part number | Memory type | Size (kB) | RAM (kB) | Sub-clock | CAN ch |
|-------------|-------------|-----------|----------|-----------|--------|
| MB90F347CE | Flash* | 128 | 6 | Yes | 1 |
| MB90F347CES | Flash* | 128 | 6 | No | 1 |
| MB90F867E | Flash* | 128 | 6 | Yes | 0 |
| MB90F867ES | Flash* | 128 | 6 | No | 0 |
| MB90F349CE | Flash* | 256 | 15.75 | Yes | 1 |
| MB90F349CES | Flash* | 256 | 15.75 | No | 1 |
| MB90F342CE | Flash* | 256 | 15.75 | Yes | 2 |
| MB90F342CES | Flash* | 256 | 15.75 | No | 2 |
| MB90F345CE | Flash | 512 | 20 | Yes | 2 |
| MB90F345CES | Flash | 512 | 20 | No | 2 |

Note: *Mask ROM version is also available.

16-bit CAN BUS MICROCONTROLLERS (64-PIN)

MB90350

The MB90350 series is a derivative of the new MB90340 series for applications that require small packages. This series offers 16-bit performance at low cost and a rich feature mix in a small package. It provides an entry level to the new MB90340 series with full soft- and hardware compatibility of the embedded peripherals. CAN, I²C bus, flexible UART interface providing LIN support and 15 analogue input channels are some of the main features. A security feature is incorporated, preventing unauthorised reading of the contents of the 128kB flash memory.

Features

- Fujitsu F²MC-16LX microcontroller architecture
- Max. 24MHz CPU clock
- Flash security function
- Full CAN 2.0A/2.0B interface with flexible buffering
- 32kHz sub-clock
- LIN-USART 2ch (offering SPI mode)
- External interrupts 8ch
- A/D converter 10-bit x 15ch
- Input capture 16-bit x 6ch
- Output compare unit 16-bit x 4ch

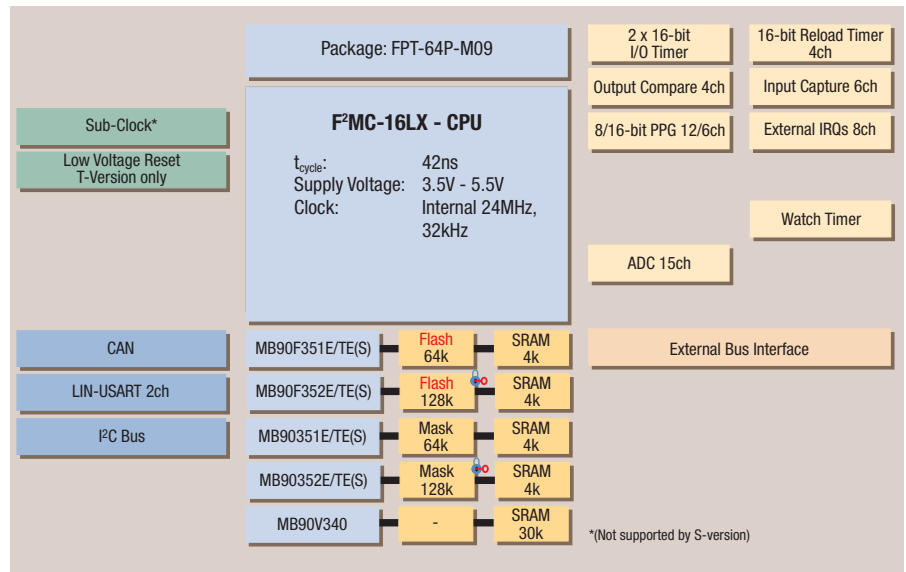

Shows the small sized MB90350 series with LIN-USART, I²C-bus, 15AD-channels, external bus and full CAN performance.

- Reload timers 16-bit x 4ch
- Programmable pulse generator 16-bit x 6ch or 8-bit x 12ch
- Option for E²PROM emulation by dual-operation flash
- QFP 64 package
- -40 to +105°C standard temperature range

| Part number | Memory type | Size (kB) | Sub-clock | Low Voltage detection Reset |
|----------------------|-------------|-----------|------------------|-----------------------------|
| MB90F352E(S) | Flash* | 128 | Not on S-version | No |
| MB90F351E(S) | Flash* | 64 | Not on S-version | No |
| MB90F352TE(S) | Flash* | 128 | Not on S-version | Yes |
| MB90F351TE(S) | Flash* | 64 | Not on S-version | Yes |

Note: *Dual-operation flash; mask ROM version is also available.

16-bit CAN BUS MICROCONTROLLERS (48-PIN)

MB90360

The MB90360 series is a subset of the powerful MB90340 series condensed in to a compact 48-pin package (7 x 7mm). It has a pin compatible footprint to other Fujitsu 48-pin CAN series (MB90385, MB90895).

Features

- Fujitsu F²MC-16LX microcontroller architecture
- Max. 24MHz CPU clock
- 64kB flash ROM (with single voltage and 10k erase cycles), or mask ROM
- Full CAN 2.0A/2.0B interface with flexible buffering (16 message buffers)
- 3kB RAM
- 32kHz sub-clock option
- LIN USARTs 2ch (offering SPI mode)
- External interrupts 8ch
- A/D converter 10-bit x 16ch
- Input capture 16-bit x 4ch
- Reload timers 16-bit x 2ch
- Programmable pulse generator 8-bit or 16-bit x 2ch
- Option for low voltage/CPU operation detection reset
- QFP 48 package
- -40 to +105°C temperature range

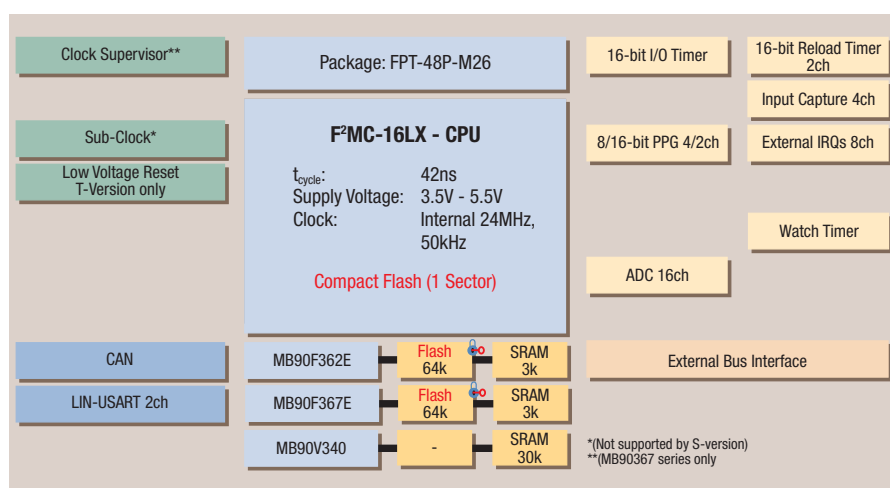

1: Only for devices without S-suffix

2: Only for devices with T-suffix

Shows the MB90360 series available in compact 48-pin package.

*(Not supported by S-version)
**(MB90367 series only)

| Part number | Memory type | Size (kB) | Sub-clock | Low Voltage detection Reset |
|----------------------|-------------|-----------|------------------|-----------------------------|
| MB90F362E(S) | Flash* | 64 | Not on S-version | No |
| MB90F362TE(S) | Flash* | 64 | Not on S-version | Yes |

Note: *Mask ROM version is also available.

16-bit **DOUBLE CAN BUS MICROCONTROLLERS** **(120-PIN) MB90390**

The MB90390 is designed for demanding 16-bit automotive applications, especially instrument clusters.

Features

- Fujitsu F²MC-16LX microcontroller architecture
- Max. 24MHz CPU clock
- 384kB, 512kB flash ROM (with single voltage and 10k erase cycles), or mask ROM
- 2 full CAN 2.0A/2.0B interfaces with flexible buffering
- 10kB, 30kB RAM
- Stepper motor controller-driver 6ch
- Sound generator
- UART 2ch
- LIN-USART (offers SPI mode) 1ch
- Synchronous serial I/O
- External interrupts 8ch
- A/D converter 10-bit x 15ch
- Input capture 16-bit x 6ch
- Output compare 16-bit x 6ch
- Reload timers 16-bit x 2ch
- I²C (MB90F395HA only)
- Programmable pulse generator 16-bit x 6ch or 8-bit x 12ch
- QFP 120 package
- -40 to +85°C temperature range

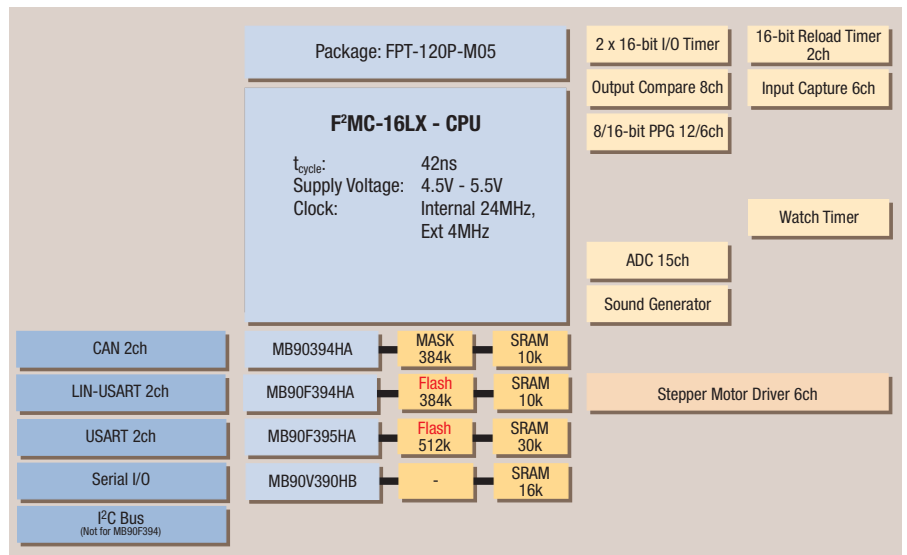

Flash version = MB90F395HA (512kB flash, 30kB RAM)
= MB90F394HA (384kB flash, 10kB RAM)

Shows the MB90390 series with 6 stepper motor controller-drivers, LIN-USART and full dual CAN performance.

16-bit **USB MICROCONTROLLERS MB90330/335**

The MB90330/335 series are a line-up of high-performance 16-bit MCUs (F²MC-16LX family) with built-in USB macros, supporting USB-Function and simplified USB-Minihost. This allows a USB device to act either as a USB-Host or as a USB-Function. In this way, USB peripheral devices can exchange data without the mediation of a PC. USB drivers are available free-of-charge.

Features

- Technology 0.35µm CMOS
- Max. 24MHz CPU clock
- Operating voltage 3.0-3.6V
- USB 2.0 compliant
- 12Mbps full-speed
- Up to 6 endpoints
- DMAC supported
- SIO
- 16-bit reload timer
- 16-bit pulse width counter
- 8 x external interrupts
- **USB driver available free**

http://www.thesycon.de/eng/prod_usbfirmware.shtml

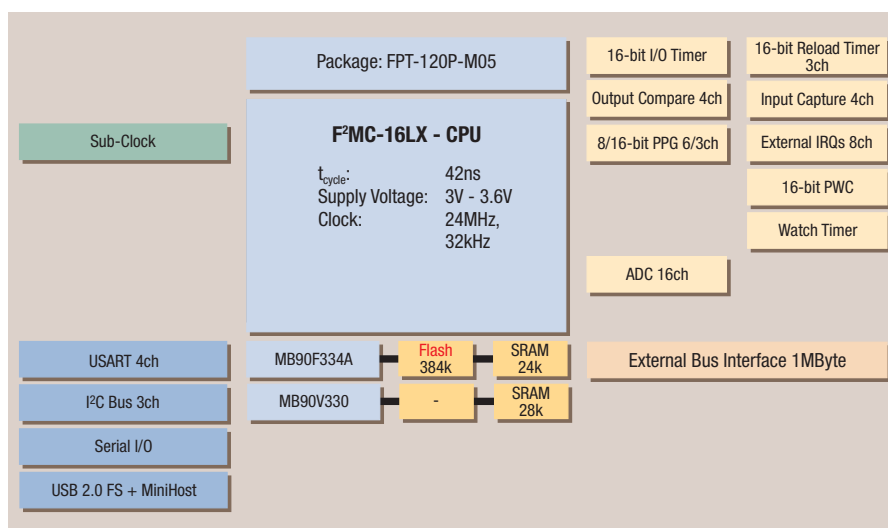

Shows the MB90F334 series with USB and USB Minihost function.

Product Line-up

| Device | MB90F334 | MB90333 | MB90F337 | MB90337 |
|---------------|------------------------|---------------|------------------------|--------------|
| ROM density | 384kBytes flash | 256kBytes ROM | 64kBytes flash | 64kBytes ROM |
| RAM density | 24kBytes | 16kBytes | 4kBytes | |
| Packaging | 120-pin LQFP | | 64-pin LQFP | |
| A/D converter | 8/10-bits, 16ch | | — | |
| UART | 4ch | | 2ch | |
| I²C | 3ch | | 1ch | |
| PPG timer | 3 x 16-bit / 6 x 8-bit | | 2 x 16-bit / 4 x 8-bit | |

PRODUCT OVERVIEW
MICROCONTROLLERS

16-bit FX BLOCK DIAGRAMS

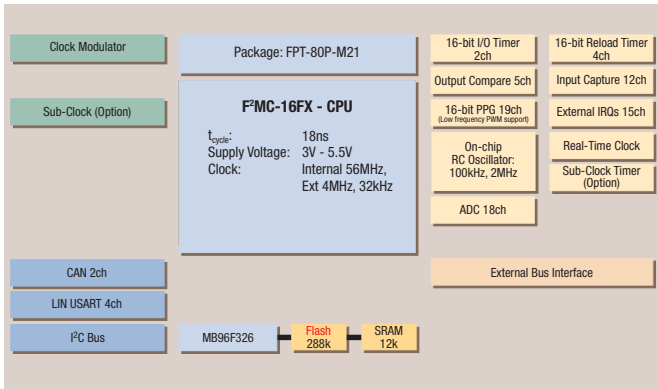

MB96320 FX series block diagram.

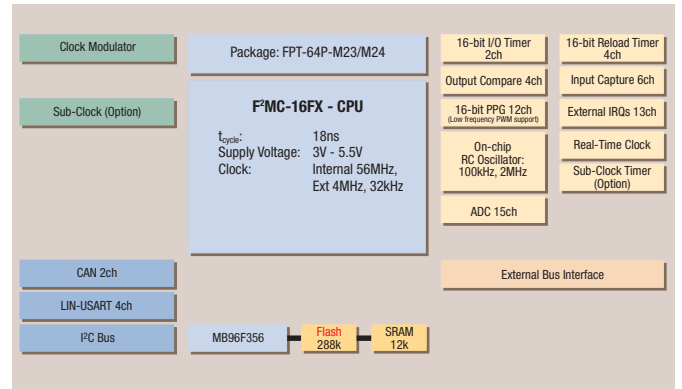

MB96350 FX series preliminary block diagram.

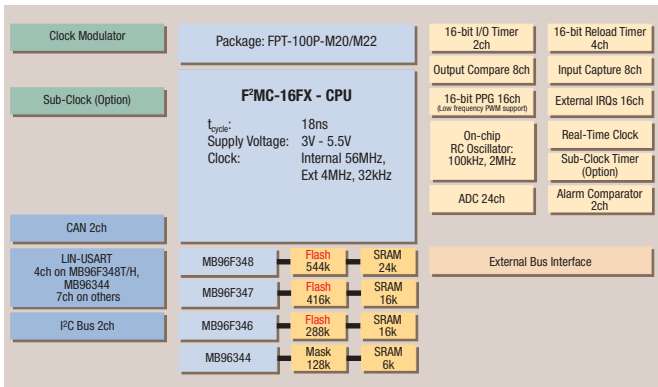

MB96340 FX series preliminary block diagram.

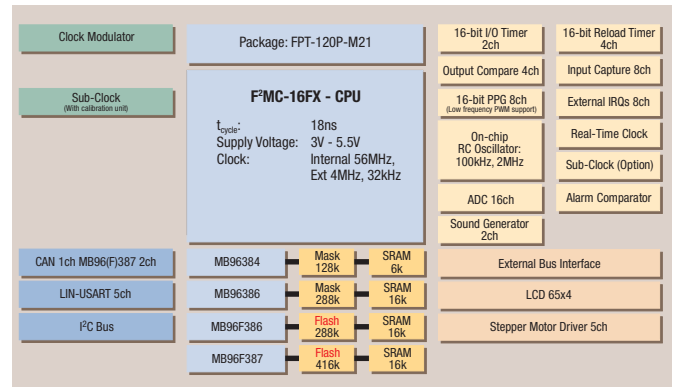

MB96380 FX series preliminary block diagram.

16-bit F²MC-LX COMPATIBILITY OVERVIEW

| | | | | | | |
|--------|--|--|--|---|---|---------------------------------|
| 2 CAN | MB90F543G 128kB Flash, 6kB RAM | MB90F594G 256kB Flash, 6kB RAM | MB90543G 128kB ROM, 6kB RAM | MB90F342 256kB Flash, 16kB RAM | | 16FX 64-pin MB96350 |
| | MB90F591G 384kB Flash, 8kB RAM | MB90F394 384kB Flash, 10kB RAM | MB90F395 512kB Flash, 30kB RAM | | MB90342 256kB Flash, 16kB RAM | 16FX 80-pin MB96320 |
| | MB90591G 384kB ROM, 8kB RAM | MB90594G 256kB ROM, 6kB RAM | MB90F423G 128kB Flash, 6kB RAM | MB90394 384kB ROM, 10kB RAM | MB90F345 512kB Flash, 20kB RAM | 16FX 100-pin MB96340 |
| 1 CAN | MB90F598G 128kB Flash, 4kB RAM | MB90598G 128kB ROM, 4kB RAM | | | MB90F349 256kB Flash, 16kB RAM | 16FX Speedo 120pin |
| | MB90F428G 128kB Flash, 6kB RAM | MB90428G 128kB ROM, 6kB RAM | MB90427G 64kB ROM, 4kB RAM | MB90351 64kB ROM, 4kB RAM | MB90F367 64kB Flash, 3kB RAM | |
| | MB90F546G 256kB Flash, 8kB RAM | MB90548G 128kB ROM, 4kB RAM | MB90F347 128kB Flash, 6kB RAM | MB90349 256kB ROM, 16kB RAM | MB90367 64kB ROM, 3kB RAM | |
| | MB90F548G 128kB Flash, 4kB RAM | MB90547G 64kB ROM, 2kB RAM | MB90549G 256kB ROM, 6kB RAM | MB90F362 64kB Flash, 3kB RAM | MB90362 64kB ROM, 3kB RAM | |
| | MB90F497G 64kB Flash, 2kB RAM | MB90F498G 128kB ROM, 2kB RAM | MB90347 128kB ROM, 6kB RAM | MB90F351 64kB Flash, 4kB RAM | MB90947A 128kB ROM, 6kB RAM | |
| | MB90497G 64kB ROM, 2kB RAM | MB90F897 64kB Flash, 2kB RAM | MB90F352 128kB Flash, 4kB RAM | MB90352 128kB ROM, 4kB RAM | MB90351 128kB ROM, 4kB RAM | |
| | MB90F947A 128kB Flash, 6kB RAM | MB90F387 64kB Flash, 2kB RAM | MB90387 64kB ROM, 2kB RAM | MB90F949A 256kB Flash, 12kB RAM | MB90F946A 128kB Flash, 16kB RAM | |
| | MB90F457 64kB Flash, 2kB RAM | MB90457 64kB ROM, 2kB RAM | MB90F438L 128kB Flash, 4kB RAM | MB90F439 256kB Flash, 6kB RAM | MB90F867 128kB Flash, 6kB RAM | |
| No CAN | | | MB90438L 128kB ROM, 4kB RAM | | MB90867 128kB ROM, 6kB RAM | |

| | | | | | | |
|-------------------|---------------------------|-----------------------------------|----------------------------|---------------------------|-----------------------------|----------------------------|
| 48pin 7 x 7 mm | 100pin External Bus | 100pin Stepper Motor LCD | 100pin Stepper Motor | 100pin External Bus | 100pin Stepper Motor | 120pin Stepper Motor |
| | | 80pin External Bus | 64pin External Bus | 64pin External Bus | 100pin Cost Optimised | 120pin 16FX Speedo |

Same colour = same pin-out.

16-bit F²MC-LX/FX **COMPATIBILITY OVERVIEW**

| Package size | Pin compatible 16LX series | Available 16FX products | 16FX products under development |
|----------------|---|---|--|
| 144-pin | - | - | MB96F338 (544kB Flash) MB96F337 (416kB Flash) |
| 120-pin | - | MB96F387 (416kB Flash) MB96F386 (288kB Flash) | MB96384 (128kB ROM) |
| 100-pin | MB90340 128kB-512kB Flash 128kB-256kB ROM MB90860 128kB Flash / ROM | MB96F348H (544kB+32kB Flash) MB96F348R (544kB Flash) MB96F347R (416kB Flash) MB96F346R (288kB Flash) | MB96F345H (160kB+32kB Flash) MB96344R (128kB ROM) |
| 80-pin | - | - | MB96F326 (288kB) |
| 64-pin | MB90350 64kB-128kB Flash / ROM | - | MB96F356 (288kB) |
| 48-pin | MB90360 64kB Flash / ROM MB90960 64kB Flash | - | MB96F365 (160kB Flash) |

16-bit flash microcontrollers compatibility overview.

Fujitsu reserves the right to change the specification of products under development without notice.

16-bit **SUPPORT TOOLS**

16FX tools

16FX is supported by Fujitsu's proven emulator for 32-bit FR series.

The Software tools (Softune Workbench) are free-of-charge for customers in Europe.

One evaluation chip covers a host of future 16FX products. A complete system comprises the following items:

- Emulator: MB2198-01 (see page 43)
- MCU adaptor board (for Eva-chip connection) MB2198-500
- Eva-chip MB96V300
- IC package specific header board (for connection to target hardware)
- Target board (see next pages)

MB2147-01 16LX emulator

Features

- Supports all Fujitsu 16LX microcontroller series
- Microcontroller operating frequency: max 25MHz
- Emulation memory: 1M x 4 area
- Fully Softune Workbench integrated user interface
- Simplified graphic interface operation execution using pull down menu and buttons
- On-The-Fly function (commands can be run during microcontroller execution)
- Powerful trace function
- Displays source codes, variables, register, memory and trace on multi-windows
- Event trigger allows a wide range of conditions to be specified (code x 8 / data x 8)
- Sequential control in 4 conditions and 3 levels
- Performance measurement function (measurement of execution speed between two points, iteration count measurement)
- Code coverage measurement function (program execution coverage rate measurement)
- Host I/F (standard accessories): RS-232C (max 115kbps), LAN (10BASE-T, 100BASE-TX), USB 1.1
- LCD display for set-up and emulator status
- Menu keys for LCD dialogue



MB2198-500 Main unit and adaptor board of the 16FX high-speed emulator.



MB2198-01 Fujitsu's emulation system for 32-bit RISC architecture.

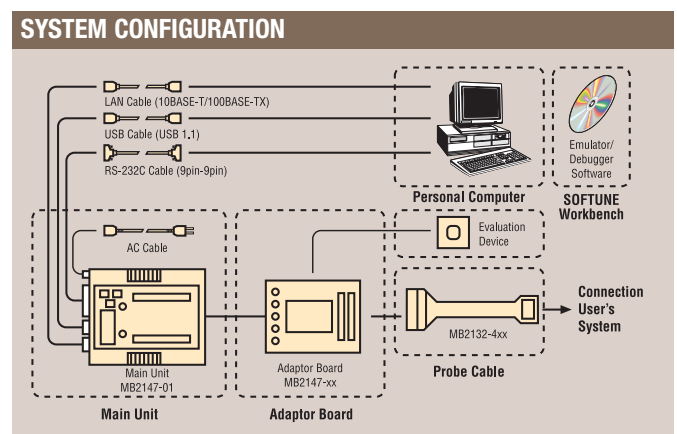

EVALUATION Boards

Fujitsu supports development engineers with low cost multi-functional evaluation boards for almost every Fujitsu 16-bit flash microcontroller.

These boards can be used stand-alone for software development and testing or as a simple target board to work with the emulator system. (Fujitsu in-circuit emulators require a target system that provides Vcc and GND, as well as a clock-circuit and reset). The boards allow the designer to start immediately with the software development.

Features

- In-circuit serial flash programming
- All resources available for evaluation
- All pins routed to connectors
- 8 user LEDs
- Reset button
- Crystal for main clock and for sub-clock where applicable
- 9 to 12V unstabilised external DC power supply usable
- English documentation and CD-ROM included

FLASH-CAN-48P evaluation board

- 16LX series supported: MB90360, MB90385, MB90455 and MB90890
- One UART interface
- One LIN transceiver
- One high-speed CAN transceiver
- 8 user LEDs, optional: alphanumeric standard LC-Display connectable instead of LEDs
- 5 user-buttons configurable for INT4, INT5, TIN0, IN0 and ADTG*
- 64-pin VG connector (same pin-out as Flash-CAN-64P-M09-V2)

Order code:

FLASH-CAN-48P-M26 with 48-pin QFP socket and MB90F387.

*The functions assigned to user buttons may vary depending on which MCU is used.

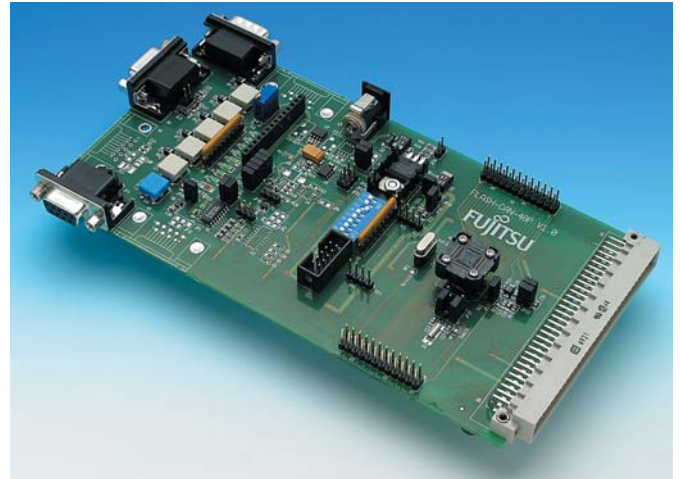

Flash-CAN-48P evaluation board.

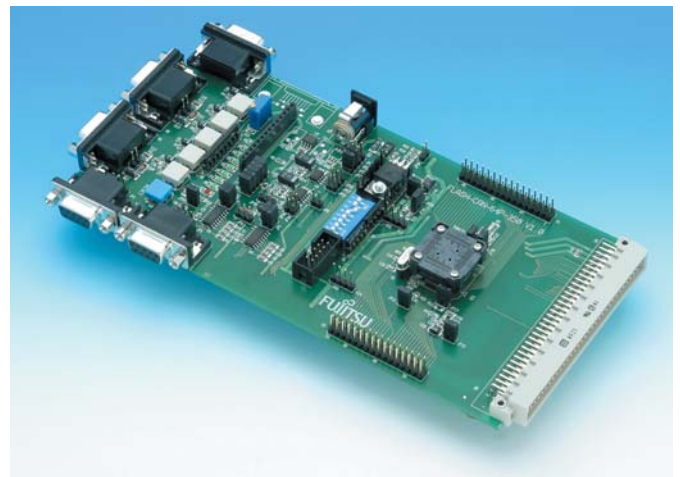

Flash-CAN-64P-350 evaluation board.

FLASH-CAN-64P-350 evaluation board

- 16LX series supported: MB90350 series with package code 'PFM'
- MB90350 series: MB90F351 & MB90F352
- Two UART interfaces
- Two LIN transceivers
- One high-speed CAN transceiver
- 8 user LEDs, optional: alphanumeric standard LCD connectable
- 5 user buttons configurable for INT10, INT11, IN0, IN1, TIN1*
- QFP-64 socket
- 96-pin VG connector
- Delivered with MB90F352PFM

Order code:

Flash-CAN-64P-350

FLASH-CAN-100P-340 evaluation board

- 16LX series supported: MB90340, MB90865. Version 1.1 onward also MB90800, MB90945 package code 'PF'
- MB90340 series: MB90V340, MB90F34x
- 16FX series MB96340 support version 1.2 onward
- Two UART interfaces
- Two LIN transceivers
- Two high-speed CAN transceivers
- 8 user LEDs, optional: alphanumeric standard LCD connectable instead of LEDs
- 5 user-buttons configurable for INT0, INT1, TIN1, IN0 and ADTG/TIN0*
- QFP-100 socket for device (with package code 'PF') or emulator connection
- 96-pin VG connector
- Delivered with flash microcontroller MB90F34x

Order code:

Flash-CAN-100P-340

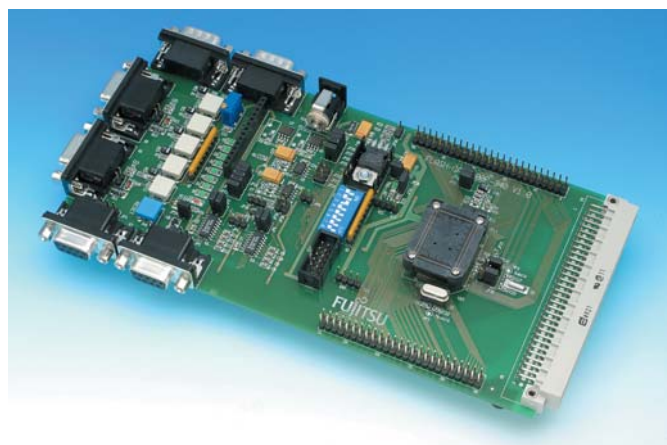

Flash-CAN-100P-340 evaluation board.

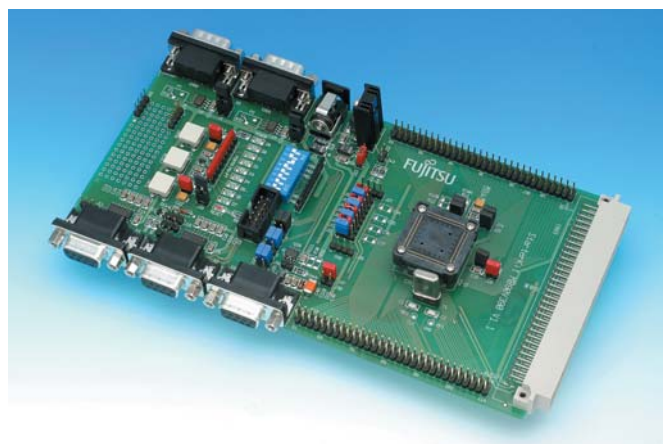

Flash-CAN-120-390 evaluation board.

FLASH-CAN120-390 evaluation board

- 16LX series supported: MB90390
- 5 and 3V internal power supply available
- 5 MHz main crystal
- Two UART interfaces (3 and 5V operating)
- LIN-transceiver
- Two high-speed CAN transceiver
- Two buttons configurable for external interrupts
- Prototyping area
- QFP-120 socket for device or emulator connection
- Delivered with flash microcontroller MB90F394H

Order code:

Flash-CAN120-390

*The functions assigned to user buttons may vary depending on which MCU is used.

EVALUATION Boards

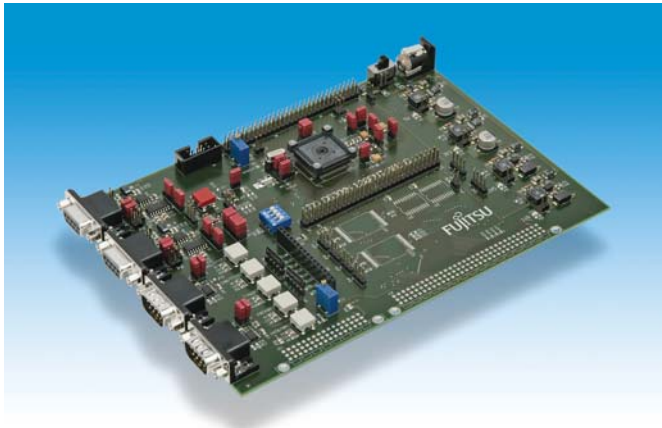

SK-96380-120PMT evaluation board.

SK-96380-120PMT evaluation board for Speedo-120 series

- Supports Fujitsu's MB96380-LQFP(M21) MCU in 120 PMT package or the MB2198 emulator system with the probe cable MB2198-16FX-120P-M21
- 9-15V unregulated external DC power supply
- 5V, 3.3V, 2.5V and 1.8V on-board switching mode voltage regulators
- Power-LEDs for all supply voltages
- On-board voltage supervisor monitors three of four supply voltages
- In-circuit serial flash programming (UART0 or UART1)
- All resources available for evaluation
- All MCU pins routed to connectors
- 4 MHz main-crystal
- 32 kHz crystal for sub-clock operation
- 2 RS232- or LIN interfaces and 2 CAN interfaces are usable simultaneously
- 3V capable CAN, LIN and RS232 transceivers
- 8 User LEDs
- Optional: alphanumeric standard LC-Display connectable instead of LEDs
- Reset-button, Reset-LED
- 5 User-buttons

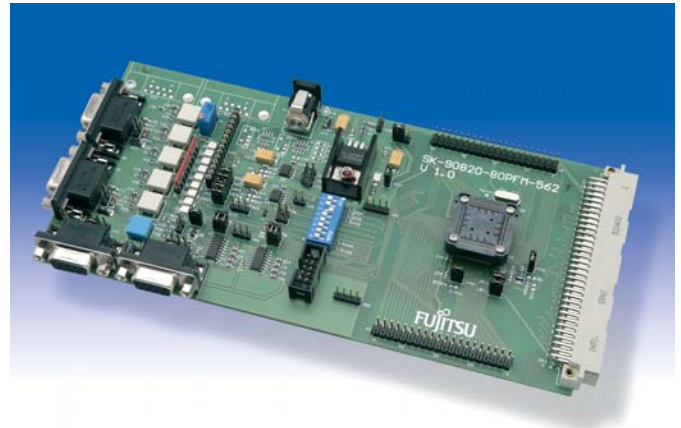

SK-90820-80PFM-562 evaluation board.

SK-90820-80PFM-562 evaluation board for motor control series

- 16LX series supported: MB90820 in 'PFM' package
- 80-pin socket for device (package code PFM) or In-circuit emulator connection
- 9-12V unregulated external DC power supply usable
- 5V internal power supply, Power-LED
- In-circuit serial flash programming
- All resources available for evaluation
- All pins routed to connectors
- 4 MHz main-crystal
- Two UART interfaces
- Two LIN interfaces
- 8 User LEDs, optional: alphanumeric standard LC-Display connectable instead of LEDs
- Reset-button, Reset-LED
- 5 User-buttons
- 96-pin VG connector
- Delivered with flash microcontroller MB90F823. This microcontroller contains a 'burn-in' boot loader for programming the flash

Order code:

SK-90820-80PFM-562

Introduction to the FR FAMILY - 32-BIT RISC ARCHITECTURE

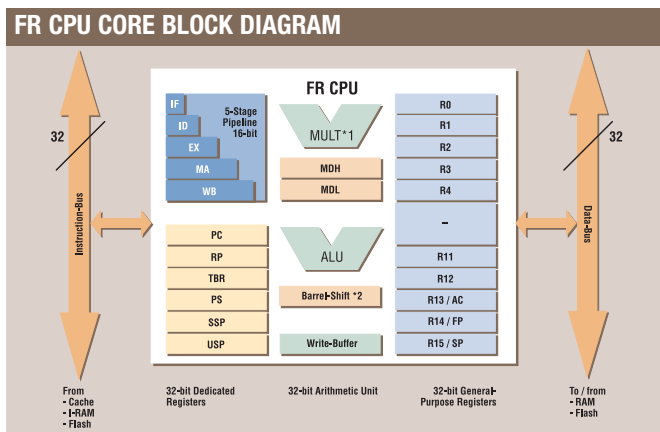

*1: 32-bit x 32-bit: 5 clock cycles, 16-bit x 16-bit: 3 clock cycles. *2: 1 cycle.
 IF: Instruction Fetch. ID: Instruction Decode. EX: Execution. MA: Memory Access.
 WB: Write Back. PC: Program Counter. RP: Return Pointer. TBR: Table Base Register.
 PS: Program Status. SSP: System Stack Pointer. USP: User Stack Pointer.
 AC: Accumulator. FP: Frame Pointer. SP: Stack Pointer.

The Fujitsu RISC (FR) architecture is a 32-bit microprocessor core that is dedicated to resolving the twin demands of high performance coupled with low cost, which are needed by today's high-end automotive, consumer and industrial applications. Designed from the outset to be optimised for embedded applications, the CPU has 16-bit instructions, enabling maximum performance from low-cost, half-word external memory or else allowing double instruction fetches for each bus cycle. The CPU employs a five-stage pipeline, a 32 x 32 multiplier, a barrel shifter and a bit search unit which finds the first 1, 0 or change in a data word in a single cycle.

The CPU has eight dedicated 32-bit registers: program counter, processor status, interrupt table base register, return pointer, system and user stack pointers and two for multiply/divide result. There are sixteen 32-bit, general-purpose registers arranged as a single bank. The functions of R13 to R15 are reserved as virtual accumulator, frame pointer and stack pointer respectively. The instruction set contains bit manipulation instructions and data moving instructions, which are very helpful in supporting the on-chip peripheral blocks. Although the FR is a RISC, it contains a number of extended instructions, which help assembly level programming, often unavoidable in embedded applications. An example is the store of half of the register bank to memory.

Blocks that require fast access are connected to the FR-core within a 32-bit Harvard Bus system. These units are the internal RAM, the DMA-controller and the bit search unit. Resources that require simple control or status access, such as UARTs, timers, etc., are hooked up on a peripheral bus known as the R-Bus. The external bus gives the user the opportunity to access external memory or other memory-mapped devices on the target application, supporting up to 8 fully configurable chip-select areas.

Fujitsu has developed a suite of FR cores from FRLite to FR80 – for different performance requirements. The FRLite core has been designed with the aim of reducing die size, power consumption and the design turnaround time.

This core closes the performance- and cost-gap between today's 16LX and FR controllers. By also being offered with the same resources it eases the migration from the 16LX CISC world into the FR RISC domain. Most of the current families are based on the FR60 core family containing the FR50 and FR70 core variants.

FR80 is used for high-speed processor type devices requiring both instruction and data cache.

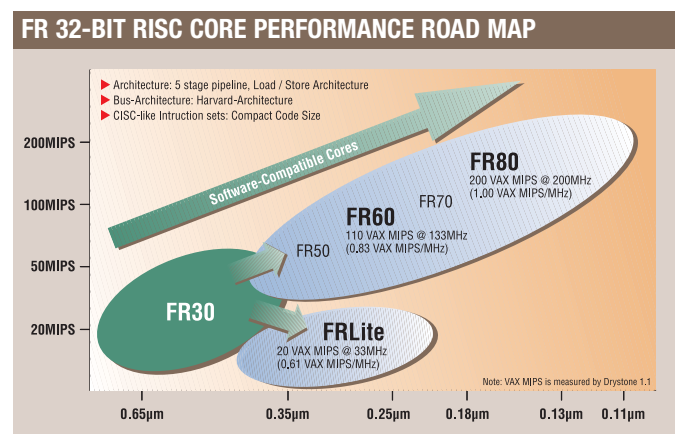

From FRLite's low power/low cost technology to FR80's optimised performance, the FR core roadmap offers a wide range of software-compatible cores dedicated to embedded applications.

MB91270 Automotive series

The FRLite series MB91270 (based on EVA device MB91V280) includes 100-pin devices (MB91270) for automotive body control and other 5V CAN applications.

As with all FRLite series, MB91270 offers:

- FRLite 32-bit RISC CPU, load/store architecture, 5-stage pipeline
- Operation frequency: 32MHz
- Instructions compatible with FR families
- Access to flash memory without wait states
- DMA
- Various timer and counter functions
- Operating voltage: 5V
- CMOS 0.35µm technology

In addition, the following feature set is available:

- ADC
- Flash: up to 512kB
- RAM: up to 48kB
- CAN
- LIN-USART
- I²C

MB91F272, the first device in this series, is pin-compatible to the successful 16-bit MB90340 series and offers the following features (see block diagram):

- Flash: 256kB
- RAM: 10kB
- CAN: (1ch, 32 message buffers)
- LIN-USART: (7ch)
- I²C: (3ch)
- 10-bit ADC: (24ch)

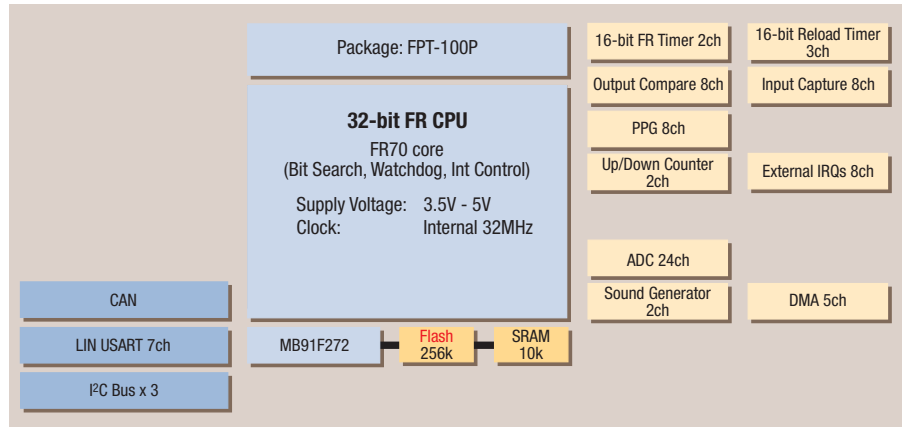

Automotive body control MCU with 1 x CAN and 7 x LIN (pin compatible to 16-bit MB90340 series).

- Various timer and counter functions:
 - 16-bit PPG (8channels)
 - 16-bit reload timer (3ch)
 - 16-bit free running timer (4ch)
 - Output compare (8ch)
 - Input capture (8ch)
 - 16-bit up/down counter (2ch)
- External Interrupts: 16ch

For evaluation and software development, the MB90340 starter-kit Flash-CAN-100P-340 is available together with the adaptor ADA-91270-90340-100PFV.

MB91360G Automotive series

MB91360G series with up to 3 full-CAN interfaces and 768kB single voltage flash memory

Created in Fujitsu's 0.35µm CMOS embedded flash process, MB91360G devices with on-chip flash memory and CAN are ideal for a wide range of automotive and industrial applications. MB91360G parts are being used in high-end instrumentation systems today, where special on-chip features such as stepper motor controllers, real-time clock, sound generator, high current LED drivers and PPGs for light dimmers, are important.

The MB91360G series offers devices with the same FR50 core, but with different peripheral and package options. All available devices are shown in the table of the 32-bit product line-up. Some example block diagrams are shown here.

MB91F362G offers over 20 on-chip peripherals including 3 CAN controllers, external bus interface and stepper-motor controllers. The package used for the MB91F362G is a QFP208. MB91F369G is a more compact variant (QFP-160), but still offering an external bus interface to e.g. connect Fujitsu graphics controllers.

MB91F364G, MB91F367G and MB91F368G are the low-end devices of the MB91360 series. These devices are useful for single-chip applications and are therefore housed in a compact QFP120 package. MB91F364G includes the new EDSU (embedded debug support unit), which allows user friendly on-chip debugging if used together with the Accemic MDE.

For the other members of the MB91F360G series, please see the table at the end of this chapter.

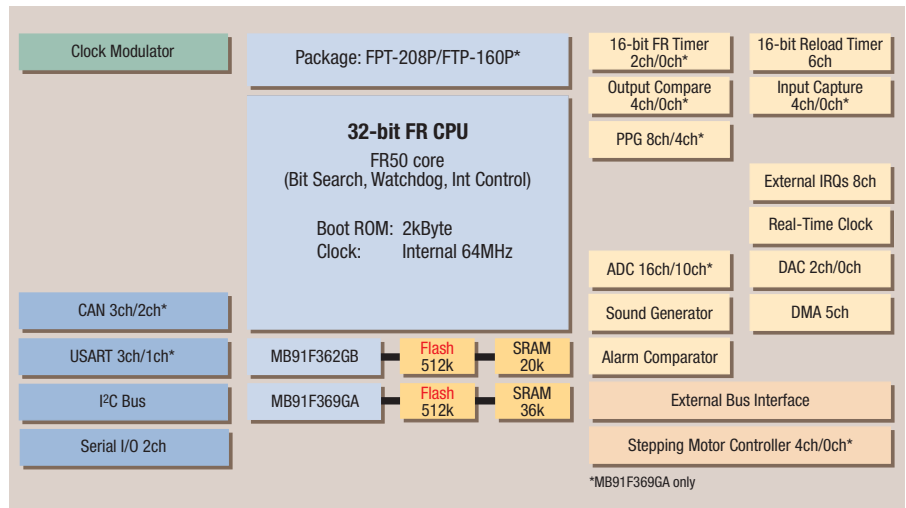

MB91F362G and MB91F369G featuring various communication interfaces (up to 3 x CAN) and an external bus interface.

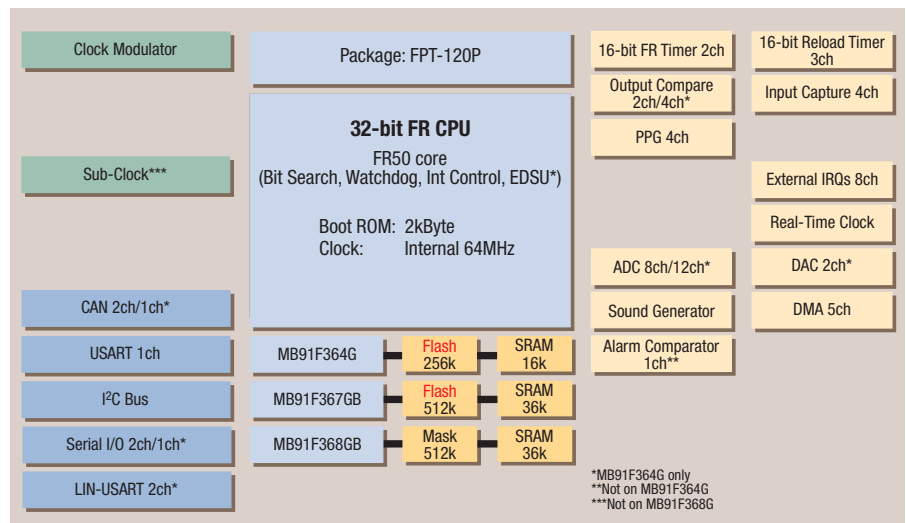

MB91F364G, F367G, F368G: Low-end single-chip devices of the MB91360G series featuring a rich set of peripherals.

MB91460 Automotive series

The FR-based MB91460 series (based on 0.18µm embedded flash technology) offers devices for car dashboard, car body control, car infotainment and also FlexRay™ applications, e.g. in the chassis area. It is a successor of the well-established MB91360G series.

Most of the devices feature a common set of basic features like:

- FR70 core (out of the FR60 core family), operating up to 100MHz
- Up to 4MB embedded flash with 64kB and 8kB sectors
- Flash security (read-out protection, additional write protection for selected sectors)
- Prefetch / Cache architecture to speed-up access to the on chip flash
- An EDSU/MPU unit, which either will be used for on-chip debugging using the ACCEMIC MDE environment or as a memory protection unit
- A BootROM to support initialisation of the MCU and also safe reprogramming in the field
- A hardware watchdog, which is running based on the on-chip RC oscillator and independent of the main clock
- A clock modulator to significantly improve EMC behaviour
- DMA, with 5 channels, which can be configured in a very flexible way (see hardware manual for details)

For other features see the detailed block diagrams.

The devices are operating on a single supply voltage between 3.0 and 5.5V. The standard operating temperature is between -40 and +105°C. Operation up to 125°C is possible (check details with Fujitsu, please).

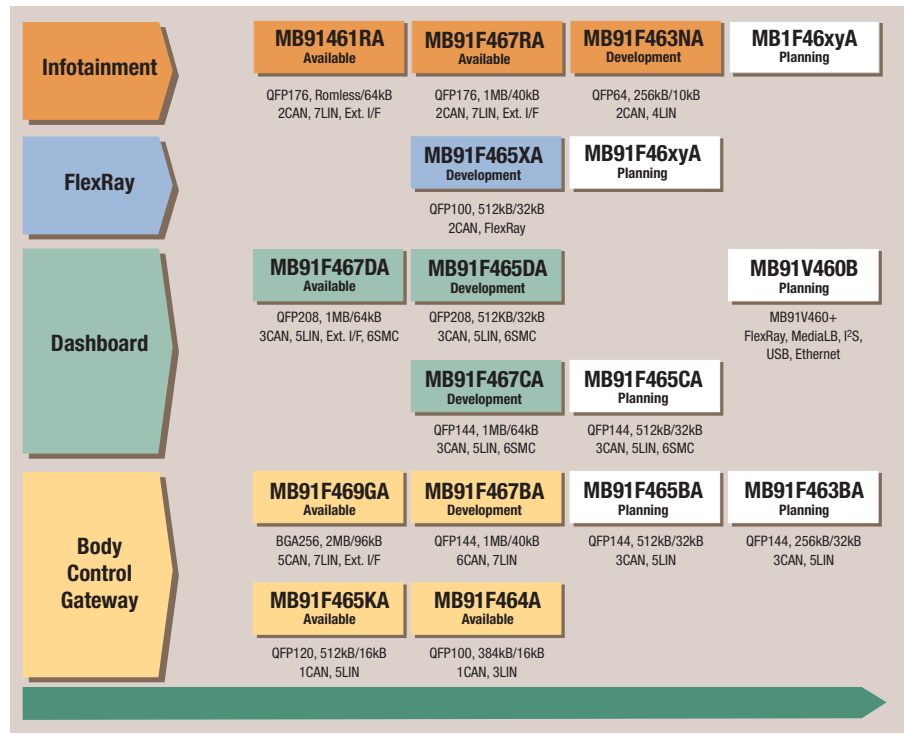

MB91460 line-up.

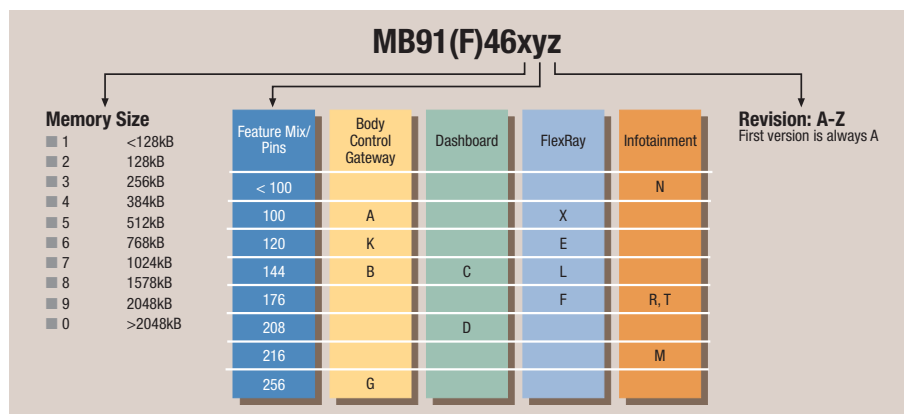

MB91460 naming conventions.

The current MB91460 line-up (MCUs, which are available, under development or under planning) is shown on the diagram.

See the diagram for the naming rules of the MB91460 series, for additional feature mix / package combinations other characters will be defined according to demand.

MB91F467DA, the first available member of the MB91460D sub-series primarily targets instrumentation, but its rich feature mix makes it suitable for various other applications as well.

Features of MB91F467DA

- 1088kB of flash memory directly connected to the CPU core via an advanced prefetch / caching system. The device includes Fujitsu's flash security feature
- 64kB of RAM
- SMC: (stepper motor controller) 6ch
- CAN: 3ch with 32 message buffers each
- LIN-UART: 5ch, (4 ch are equipped with transmit and receive FIFOs)
- External bus interface, which supports various memories, but can also be used to connect Fujitsu graphics controllers or the new FlexRay ASSP device

A starterkit in two variants (combined with the FlexRay ASSP and without it) is currently available: SK-91F467D-FLEXRAY or SK-91F467D-208PFV

The MB91F460C sub-series will provide single-chip devices with the same feature mix as the MB91F460D MCUs, but without external bus and in a QFP-144 package.

MB91F469GA so far is the flagship of the MB91460 series with 2MB of embedded flash, 6 CAN channels with 128 message buffers each, and a large set of other peripherals. It comes in a BGA-254 package offering a flexible external bus interface.

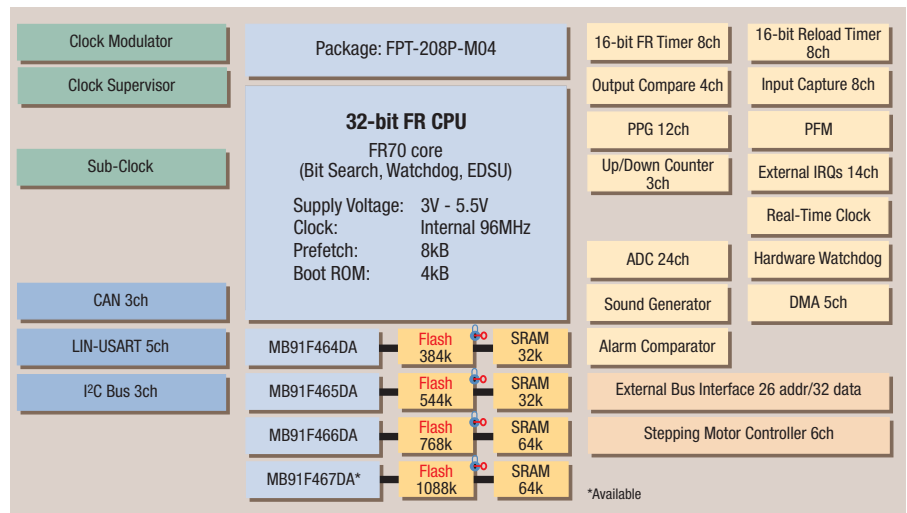

Features of the MB91460D series: 208-pin dashboard MCUs.

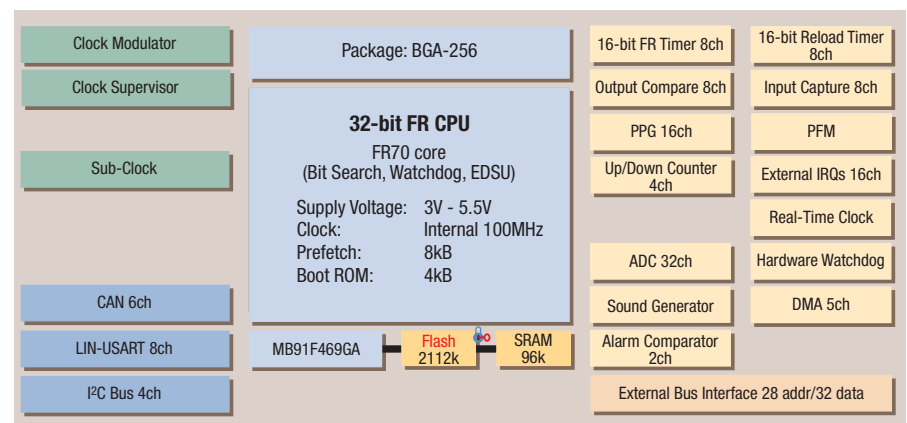

MB91F469GA: Current flagship of the MB91460 series: 2MB flash, 6x CAN.

Features of MB91F469GA

- 2MB flash
- 96kB RAM
- CAN 6ch. 128 message buffers
- LIN-UART: 8ch
- I²C: 4ch
- 10-bit ADC: 32ch
- Various timers and pulse generators

MB91460 Automotive series

MB91F464AA is a 100-pin device developed for various body control applications.

Features of MB91F464A

- 416kB flash
- 16kB RAM,
- CAN 1ch, 32 message buffers
- LIN-USART: 5ch
- 10-bit ADC: 21ch
- PPG: 10ch
- RTC module, which can operate based on the external 4MHz or 32kHz crystals
- Various timers

MB91F465KA is a sister device of MB91F464A, with some additional functions:

- 544kB flash
- QFP-120
- PPG: 12ch
- 10-bit ADC: 26ch

Soon to come are additional MB91460 sub-series, like MB91460B (144-pin body control) and MB91460X (100-pin FlexRay).

Features of MB91F467BA

The MB91460B sub-series offers devices with up to 6 CAN channels, a high count of other communications interfaces (LIN-USART, I²C), the full MB91460 set of 32 ADC channels and 16 PPG channels. The devices feature an optional external bus. If the bus is required some other peripherals cannot be used at the same time (see the block diagram for more details).

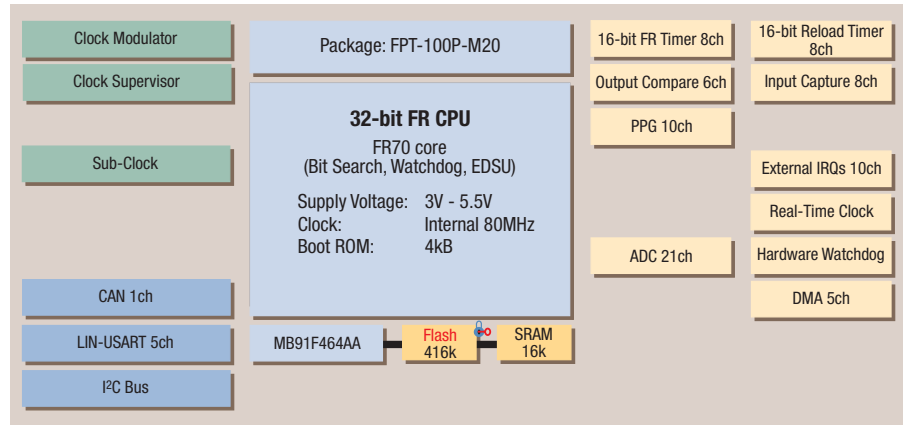

Features of the MB91F460A series.

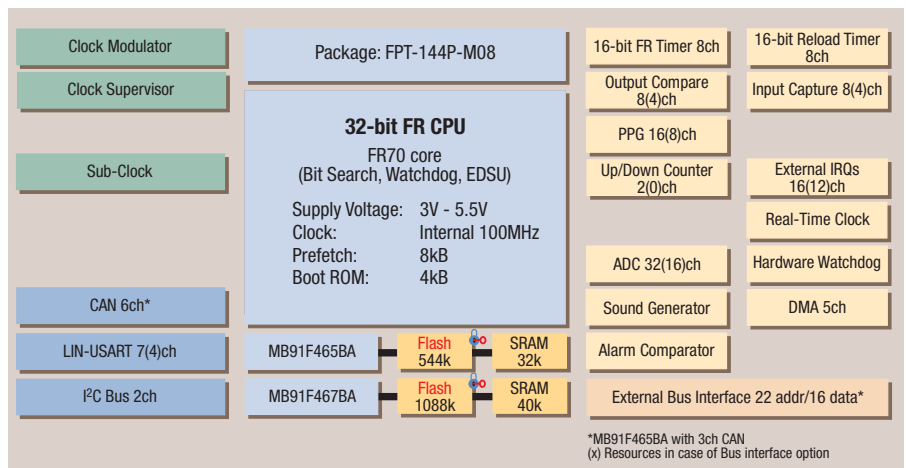

MB91460B sub-series: 144-pin body control MCUs.

MB91F465XA is the first MB91460 MCU with an embedded FlexRay interface.

Features of MB91F465XA

In addition to the double-channel (A+B) FlexRay interface (protocol specification 2.1 with an 8kB message buffer memory to support up to 128 different identifiers) it includes:

- Flash: 544kB
- RAM: 32kB
- CAN: 2ch with 32 message buffers each
- LIN-USART: 3ch
- I²C: 1 channel
- 16-bit PPG: 12ch
- 10-bit ADC: 17ch
- Various timers, compare and capture units

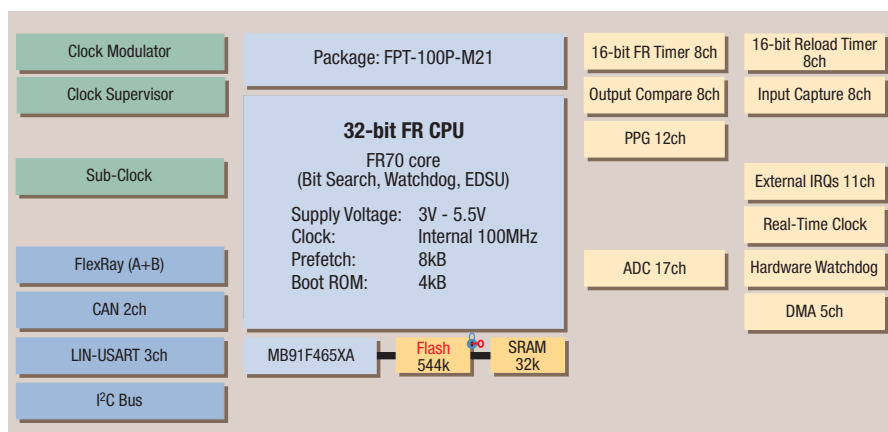

MB91460X sub-series: 100-pin embedded FlexRay MCUs.

MB88121 FlexRay communication controller

Description

The MB88121 is an application-specific standard product (ASSP) that provides the protocol engine to service the FlexRay bus system. MB88121 adds FlexRay connectivity to 16-bit and 32-bit microcontrollers that lack embedded FlexRay protocol engines. The 64-pin device acts as a companion chip to a vast number of embedded microcontrollers used in automotive applications.

- FlexRay communication controller supporting protocol version 2.1
- Configurable parallel host interface compatible with most 16-bit and 32-bit microcontrollers.
 - 16-bit multiplex and non-multiplexed access
- DMA support accessing receive message buffer data
- On-chip PLL
- Input clock 4/5/8/10MHz quartz or square wave input
- SPI interface (Max. 8Mbit/s)
- Low voltage monitoring support
- Stopwatch function
 - External event capture
- 3.0 - 5.5V single voltage supply
- Package:
 - 64-pin plastic LQFP
 - 0.5mm pin pitch

Software

- Fujitsu FlexRay Driver (FFRD)
 - Free licence for evaluation purposes
 - Source code delivery
- DECOMSYS::COMMSTACK as driver to the FlexRay interface
 - Free object code licence for use on Fujitsu development platform
- Software examples
 - FlexRay-CAN bridge
 - Keyboard demo



MB88121B adds FlexRay connectivity to 16-bit and 32-bit microcontrollers that lack embedded FlexRay protocol engines.

Development tools

- SK-91F467-FLEXRAY
 - Starter kit featuring MB91F467D 32-bit microcontroller and MB88121B
- All development tools contain 'light' or trial versions of FlexRay configuration tools from
 - DECOMSYS
 - TZM

MB91260/265 Series - 3-phase motor control

With its high-speed MAC (multiply/accumulate) unit, multi-function timer and 3 high-speed (1.2μs) A/D converter units, this embedded flash microcontroller is optimal for 3-phase motor control applications.

The multi-function timer consists of a free-running timer (up/down), output compare and input capture units, 16-bit PPG timer units and a waveform generator.

The MAC unit executes 16-bit x 16-bit multiplications and the calculation of a 40-bit sum in a single cycle of its 32MHz clock. As an added feature 64 word X- and Y-RAMs are built in. MB91F264 features 256kB embedded flash and 8kB RAM and comes in a 100-pin package. MB91F267 features 128kB embedded dual-operation flash and 4kB RAM plus 1 channel of CAN with a 64-pin package.

Features

- Process technology: CMOS 0.35μm
- Supply voltage: 4.0 to 5.5V
- Operating frequency: 32MHz
- UART communication function MB91F264 including dedicated resources for motor control
- Timer function: PPG, up/down counter, reload timer, free-running timer, watch timer, PWC timer, U-timer, Watchdog timer function, ICU, OCU
- Waveform generator (for motor drive)
- Low-power consumption mode: Sleep, Stop, and Timer modes

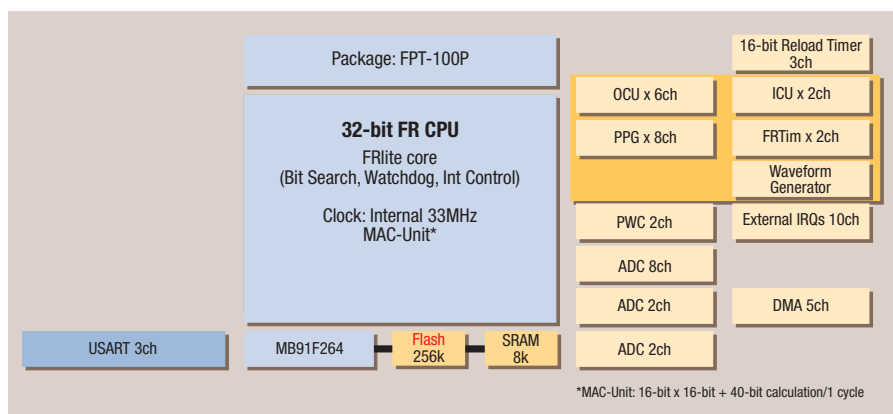

MB91F264 including dedicated resources for motor control.

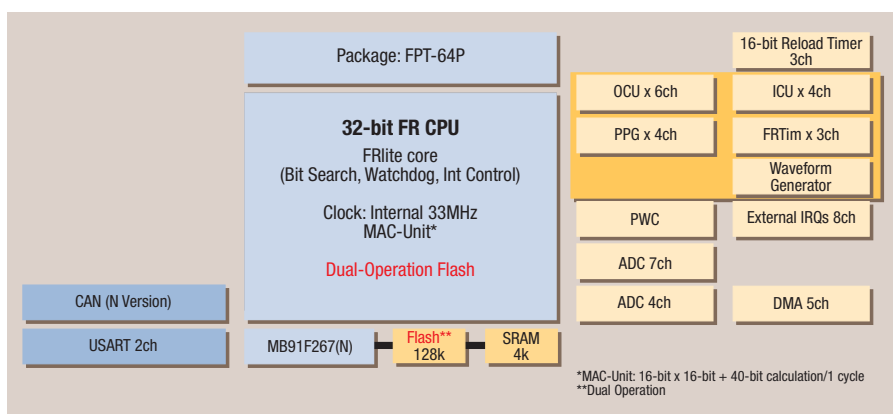

MB91F267, a compact device for motor control with an optional CAN interface.

| | MB91F264 | MB91F267 |
|-----------------|-------------------------|------------------------|
| Package | LQFP-100 | LQFP-64 |
| A/D | 2ch 2 units, 8ch 1 unit | 4ch 1 unit, 7ch 1 unit |
| USART | 3ch | 2ch |
| PWC | 2ch | 1ch |
| Ext. Int | 10ch + NMI | 8ch + NMI |
| RTim | 3ch | 3ch |
| PPG | 8ch 16-bit (16ch 8-bit) | 4ch 16-bit (8ch 8-bit) |
| CAN | - | 1ch |

Next generation **32-BIT MOTOR CONTROL MCUs**

The new MB91470/480 series extends the 32-bit MCU family to even higher performance for motor control applications. It includes many features of the MB91265 series, such as the flexible multi-function timer, the waveform generator and the fast 10-bit ADC, combined with a powerful FR70 core with up to 80MHz main clock, a 32-bit wide MAC unit, two additional 12-bit ADC units and an up/down counter with index input for encoder applications.

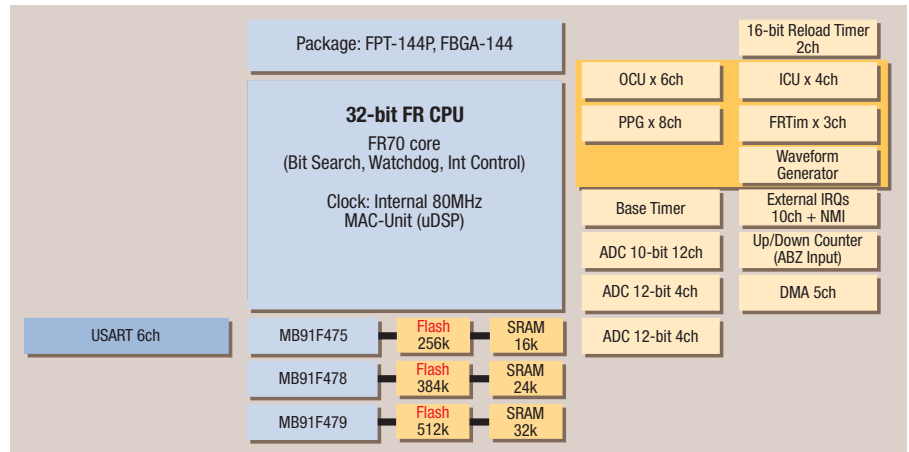

MB91470 block diagram.

MB91F470/480 Series common features

- FR70 core, max. 80MHz (with PLL)
- MAC unit: 32-bit x 32-bit + 72-bit in 1 cycle
- Up to 512kB flash, 32kB RAM
- Multi-function timer:
 - 6ch output compare, 4ch input capture
 - 4ch (16-bit) or 8ch (8-bit) PPG
 - 3ch 16-bit free-run timer
 - Waveform generator with dead-time generation and fault input
- 2ch 16-bit reload timer
- 4ch 16-bit base timer; can be used for PWM, PWC, PPG, RLT
- Up to 6ch UART with sync. / async. Modes, I²C, SPI
- 10 external interrupts + NMI
- 5ch DMA

Product Line-up

| Device | MB91470 Series | MB91480 Series |
|-----------------------|--------------------|----------------|
| Package | LQFP-144, FBGA-144 | LQFP-100 |
| External bus | yes | No |
| Up/down counter (ABZ) | yes | No |
| 3-phase motor driver | 1ch | 2ch |
| ADC | 8/10-bit, 12ch | 8/10-bit, 12ch |
| | 12-bit, 4ch | 8/10-bit, 4ch |
| | 12-bit, 4ch | 8/10-bit, 4ch |
| USARTS | 6ch | 3ch |

MB91301 Series

The MB91301 series features a powerful device based on the FR65E core fabricated in 0.25µm CMOS technology.

This SDRAM controller embedded MCU MB91302A is developed as a successor to MB91101. Operation is available at a maximum frequency of 68MHz. A 4kB instruction cache guarantees high-speed code execution. The external bus interface is compatible with a wide variety of memories, from asynchronous SRAM to page-mode and burst-mode flash. The SDRAM controller also supports FCRAM™. Five externally controllable DMA channels support many transfer modes thereby ensuring efficient transfer of data within the device. The supply voltage is 3.3V.

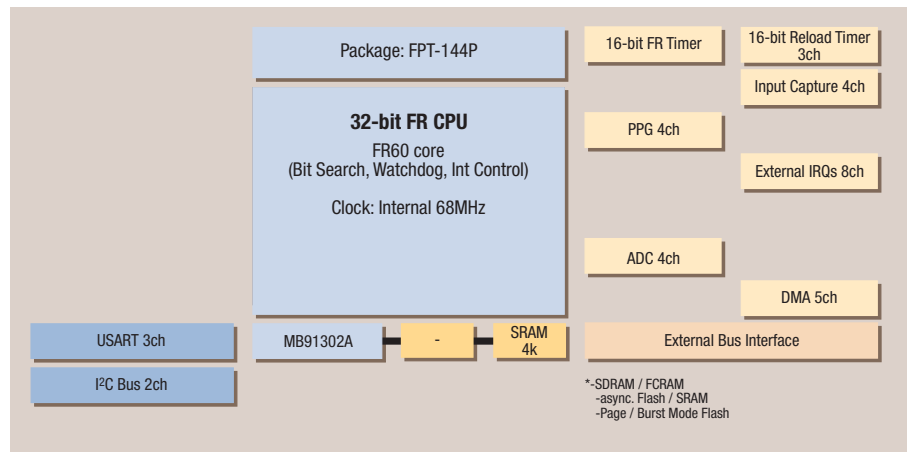

MB91302 offers a dedicated SDRAM interface and 4kB cache memory.

MB91350A Series

This series of single-chip embedded flash microcontrollers includes feature-rich devices for digital home appliances and other 3.3V embedded control applications. The devices run at an operating frequency of up to 50MHz. In addition to various timers, the devices include several serial communication interfaces (up to 5 USART, 3 SIO and also an I²C interface). A/D and D/A converters support the processing of analogue signals.

The series includes MB91F353A housed in a 120-pin package and MB91F355A with more features in a 176-pin package.

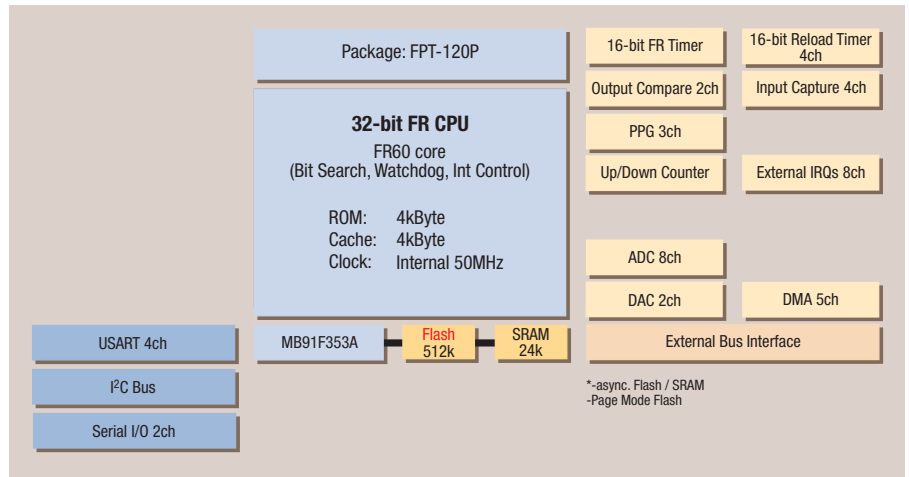

MB91F353A offers 512kByte flash and 24kByte of RAM on-chip.

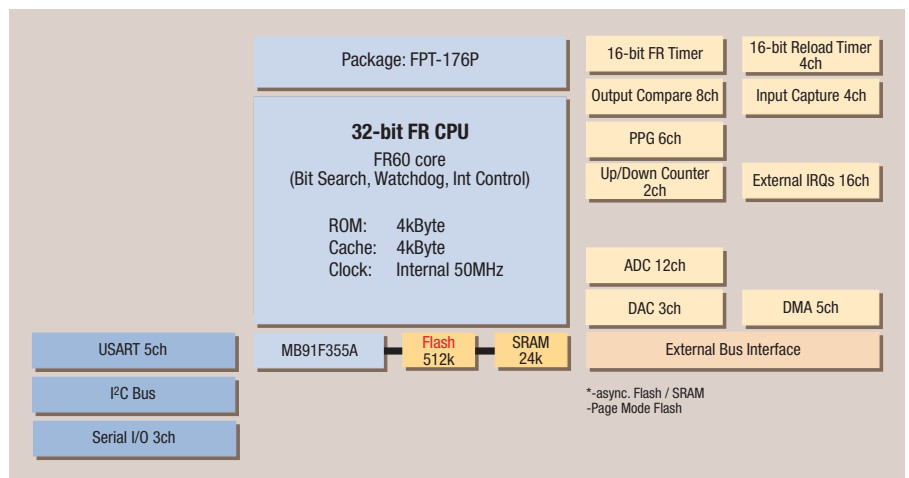

MB91F353A offers 512kByte flash and 24kByte of RAM on-chip.

| | MB91F353A | MB91F355A |
|-----------------------|-----------|-----------|
| Package | LQFP-120 | LQFP-176 |
| ICU | 4 | 4 |
| OCU | 2 | 8 |
| RTim | 4 | 4 |
| U/D counter | 1 | 2 |
| ADC | 8 | 12 |
| DAC | 2 | 3 |
| PPG | 3 | 6 |
| NMI | 1 | 1 |
| Ext. IRQ | 8 | 16 |
| I/O ports | 84 | 141 |
| I²C | 1 | 1 |
| SIO | 2 | 3 |
| USART | 4 | 5 |

FR Series - in-circuit emulator

The MB2198 is Fujitsu's emulation system for 32-bit RISC FR architecture microcontrollers.

It makes use of the DSU (Debug Support Unit) integrated within the FR evaluation devices, to provide a powerful debugging environment without compromising full system operating speed.

The system comprises the MB2198-01 emulation unit, which connects to the host PC via RS232, integrated (10BASE-F, 10BASE-F+) LAN or USB interface. The MB91VxxxCR FR evaluation device plugs into a pod or adaptor board and this, depending on the family, then plugs into either a suitable IC socket located on the target hardware, or connects to a header board and NQ-PACK on the target hardware.

Features

- Source level debugging
- Real-time trace
- 5 hardware breakpoints and 8,192 software breakpoints



MB2198-01 Fujitsu's emulation system for 32-bit RISC architecture.

FR Series - evaluation boards

Fujitsu supports development engineers with low cost multi-functional evaluation boards for almost every Fujitsu microcontroller.

These boards can be used stand-alone for software development and testing or as a simple target board to work with the emulator system. (Fujitsu in-circuit emulators require a target system that provides Vcc and GND, as well as a clock-circuit and reset). The boards allow the designer to start immediately with the software development.

Features

- In-circuit serial flash programming
- All resources available for evaluation
- All pins routed to connectors
- 8 user LEDs
- Reset button
- Crystal for main clock and for sub-clock where applicable
- 9 to 12V unregulated external DC power supply usable
- English documentation and CD-ROM included

FR Series - evaluation boards

Starterkit MB91360

- Footprint QFP208 for MB91F362G (or emulation socket), surrounded by headers for other adaptors
- 512kB external SRAM available for user code and data
- External 16550 UART (supports transfer-rates up to 115.2kBaoud)
- 2 MAX232 + DB9 (female) connectors for monitor and internal UART
- CAN transceiver and DB9 (male) for internal CAN0
- External interrupt 0 and 1 connected to buttons for user interaction
- Various jumpers for individual configuration
- 2 x 16 char LCD (on Port G)
- External bus and all resources logically grouped on pin-headers
- Stand-alone configuration features built-in monitor debugger (in flash)
- Software example projects for various applications



Starterkit MB91360

Starterkit MB91302

- Supports MB91302 series in FPT-144P-M12 package
- On-board 64Mbit flash and 64Mbit SDRAM
- In-circuit serial flash programming
- Integrated Softune Workbench monitor debugger
- All 144 pins routed to connectors
- 15MHz main-crystal
- Two UART interfaces (UART0, 1)
- 8 user LEDs, optional: alphanumeric standard LCD connectable instead of LEDs
- Reset and interrupt buttons
- Graphic controller board support (bus connection and power supply)
- Graphic controller boards are available for Fujitsu graphics controllers: MB86291A, MB86290A and MB87P2020A

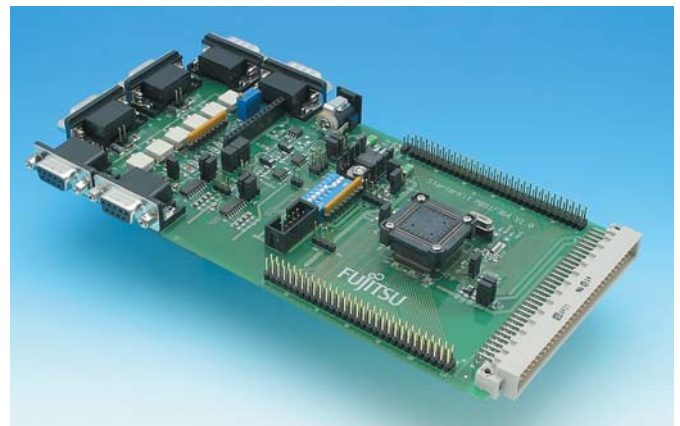

MB91302 starterkit - low cost multi-functional evaluation board.

MotorKit-91F267-MC key features

- Soldered MB91F267N MCU
- 2x UART-transceiver (SUB-D9 connector), isolated
- 1x high-speed CAN-transceiver (SUB-D9 connector), isolated
- 1x external watchdog MB3793-42
- Buttons: 4x 'User', 1x NMI, 1x DTTI (fault simulation)
- 1x 'Reset'-button, 'Reset'-LED
- 3 potentiometers
- All 64 MCU pins routed to pin-header
- On-board 5V + 15V voltage regulator, 'Power'-LEDs
- Integrated 3-phase power stage 24V/6A (higher currents possible depending on shunt resistors)
- Connectors for external power stage, Hall sensors, encoder, LCD
- Current and voltage measurements with ADC, over-current and over-voltage comparator

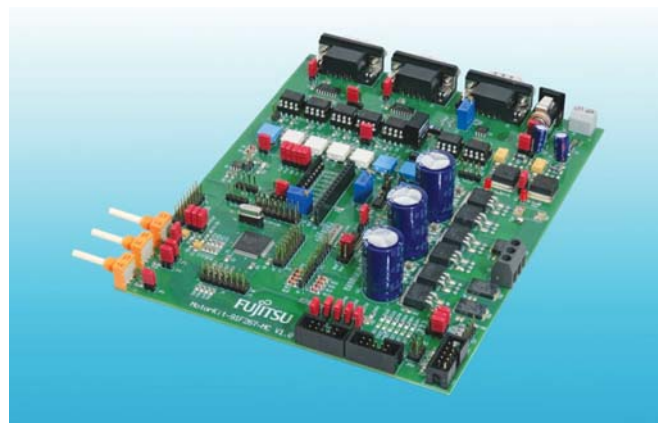

MotorKit-91F267-MC is a starter kit specially designed for 3-phase motor control.

Starterkit MB91350

- Supports MB91350A series in FPT-176P-M02 package
- On-board flash, SRAM and FRAM
- In-circuit serial flash programming
- Integrated Softune Workbench monitor debugger
- All 176 pins routed to connectors
- Two UART interfaces (UART0, 1)
- 8 user LEDs, optional: alphanumeric standard LCD connectable instead of LEDs
- Reset and interrupt buttons
- Graphics controller board support (bus connection and power supply)
- Graphics controller boards are available for Fujitsu graphics controllers: MB86291A, MB86290A and MB87P2020A

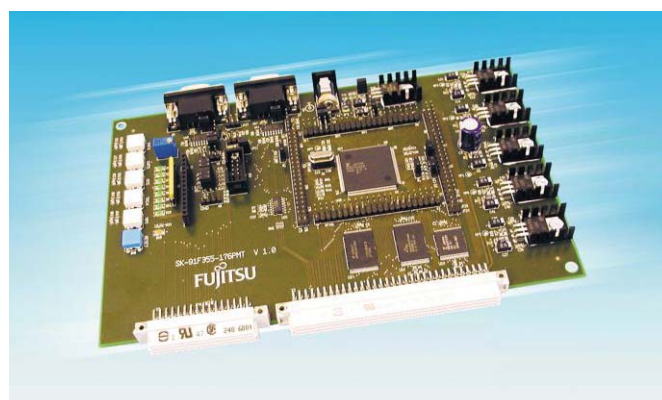

Starterkit MB91350

Starterkit SK-91F467D-208PFV

- Soldered socket for MCU
- Three selectable RS-232 or LIN UART-interfaces
- Three high-speed CAN interfaces
- 3.3 V ext. bus
- GDC I/F for graphics controller sub-boards
- 4 MByte SRAM at ext. bus
- 16 MByte flash at ext. bus
- 16 user LEDs
- Supported by SWB Monitor Debugger



Starterkit SK-91F467D-208PFV.

Similar starterkits will be provided for all MB91460 MCUs.

PRODUCT OVERVIEW MICROCONTROLLERS

32-bit FR PRODUCT LINE-UP

Overview of 32-bit Families

| Series | Device Part Number | Package (pin) | Operating voltage: Vcc 3V 5V system (V) | Max. internal clock frequency (MHz) | Clock | Memory Type | ROM (Byte) | RAM (Byte) | Cache (kByte) | External Interrupts (ch) | External Bus | A/D converter (bit x ch) | D/A converter (bit x ch) | 16-bit timer (ch) | Input capture (ch) |
|------------|--------------------|---------------|---|-------------------------------------|-------|-----------------------|------------|------------|---------------|--------------------------|--------------|-----------------------------------|-----------------------------------|-------------------|--------------------|
| MB91101 | MB91101A | 100 | 3 or 5 | 50 | 1 | No ROM / External ROM | – | 2kB | 1 | 5 | Yes | 10-bit x 4 | – | 3 | – |
| MB91230 | MB91233L | 120 | 3 | 33.6 | 2 | Mask | 256kB | 16kB | – | 16 | – | 10-bit x 8 | 8-bit x 2 | 4 | 16-bit x 2 |
| | MB91F233 | 120 | 3 | 33.6 | 2 | Flash | 256kB | 16kB | – | 16 | – | 10-bit x 8 | 8-bit x 2 | 4 | 16-bit x 2 |
| | MB91F233L | 120 | 3 | 33.6 | 2 | Flash | 256kB | 16kB | – | 16 | – | 10-bit x 8 | 8-bit x 2 | 4 | 16-bit x 2 |
| MB91260B | MB91263B | 100 | 5 | 33 | 1 | Mask | 128kB | 8kB | – | 10 | – | 10-bit x 12 | – | 3 | 16-bit x 4 |
| | MB91F264B | 100 | 5 | 33 | 1 | Flash | 256kB | 8kB | – | 10 | – | 10-bit x 12 | – | 3 | 16-bit x 4 |
| MB91265 | MB91266 | 64 | 5 | 33 | 1 | Mask | 64kB | 2kB | – | 8 | – | 10-bit x 11 | – | 3 | 16-bit x 4 |
| | MB91F267 | 64 | 5 | 33 | 1 | Flash | 128kB | 4kB | – | 8 | – | 10-bit x 11 | – | 3 | 16-bit x 4 |
| | MB91F267N | 64 | 5 | 33 | 1 | Flash | 128kB | 4kB | – | 8 | – | 10-bit x 11 | – | 3 | 16-bit x 4 |
| MB91270 | MB91F272 | 100 | 5 | 32 | 2 | Flash | 256kB | 10kB | – | 16 | Yes | 10-bit x 24 | – | 3 | 16-bit x 8 |
| | MB91F272S | 100 | 5 | 32 | 1 | Flash | 256kB | 10kB | – | 16 | Yes | 10-bit x 24 | – | 3 | 16-bit x 8 |
| MB91301 | MB91302A | 144 | 3 | 68 | 1 | Mask | 4kB | 4kB | 4 | 9 | Yes | 10-bit x 4 | – | 3 | 16-bit x 4 |
| | MB91302A-020 | 144 | 3 | 68 | 2 | No ROM / External ROM | – | 4kB | 4 | 9 | Yes | 10-bit x 4 | – | 3 | 16-bit x 4 |
| MB91350A | MB91351A | 120 | 3 | 50 | 2 | Mask | 384kB | 24kB | – | 9 | Yes | 10-bit x 8 | 8-bit x 2 | 4 | 16-bit x 4 |
| | MB91352A | 120 | 3 | 50 | 2 | Mask | 384kB | 16kB | – | 9 | Yes | 10-bit x 8 | 8-bit x 2 | 4 | 16-bit x 4 |
| | MB91353A | 120 | 3 | 50 | 2 | Mask | 512kB | 24kB | – | 9 | Yes | 10-bit x 8 | 8-bit x 2 | 4 | 16-bit x 4 |
| | MB91F353A | 120 | 3 | 50 | 2 | Flash | 512kB | 24kB | – | 9 | Yes | 10-bit x 8 | 8-bit x 2 | 4 | 16-bit x 4 |
| | MB91354A | 176 | 3 | 50 | 2 | Mask | 384kB | 16kB | – | 17 | Yes | 10-bit x 12 | 8-bit x 3 | 4 | 16-bit x 4 |
| | MB91355A | 176 | 3 | 50 | 2 | Mask | 512kB | 24kB | – | 17 | Yes | 10-bit x 12 | 8-bit x 3 | 4 | 16-bit x 4 |
| | MB91F355A | 176 | 3 | 50 | 2 | Flash | 512kB | 24kB | – | 17 | Yes | 10-bit x 12 | 8-bit x 3 | 4 | 16-bit x 4 |
| | MB91F356B | 176 | 3 | 50 | 2 | Flash | 256kB | 24kB | – | 17 | Yes | 10-bit x 12 | 8-bit x 3 | 4 | 16-bit x 4 |
| | MB91360 | MB91F362GB | 208 | 5 | 64 | 1 | Flash | 512kB | 20kB | – | 8 | Yes | 10-bit x 16 | 10-bit x 2 | 6 |
| MB91F364G | | 120 | 5 | 64 | 1 | Flash | 256kB | 16kB | – | 8 | – | 10-bit x 12 | 10-bit x 2 | 3 | 16-bit x 4 |
| MB91F365GB | | 120 | 5 | 64 | 1 | Flash | 512kB | 36kB | – | 8 | – | 10-bit x 8 | 10-bit x 2 | 6 | 16-bit x 4 |
| MB91F366GB | | 120 | 5 | 64 | 2 | Flash | 512kB | 36kB | – | 8 | – | 10-bit x 8 | – | 6 | 16-bit x 4 |
| MB91366GA | | 120 | 5 | 64 | 2 | Mask | 512kB | 36kB | – | 8 | – | 10-bit x 8 | – | 6 | 16-bit x 4 |
| MB91F367GB | | 120 | 5 | 64 | 1 | Flash | 512kB | 36kB | – | 8 | – | 10-bit x 8 | – | 3 | 16-bit x 4 |
| MB91F368GB | | 120 | 5 | 64 | 2 | Flash | 512kB | 36kB | – | 8 | – | 10-bit x 8 | – | 3 | 16-bit x 4 |
| MB91F369GA | | 160 | 5 | 64 | 1 | Flash | 512kB | 36kB | – | 8 | Yes | 10-bit x 10 | – | 6 | – |
| MB91F376G | | 120 | 5 | 64 | 2 | Flash | 768kB | 36kB | – | 8 | – | 10-bit x 8 | – | 6 | 16-bit x 4 |
| MB91460 | MB91461* | 176 | 3 | 80 | 1 | No ROM / External ROM | – | 64kB | 4 | 16 | Yes | 10-bit x 13 | – | 4 | 16-bit x 4 |
| | MB91F464AA* | 100 | 3 to 5 | 80 | 2 | Flash | 416kB | 16kB | – | 10 | – | 10-bit x 21 | – | 8 | 16-bit x 8 |
| | MB91F467BA | 144 | 3 to 5 | 100 | 2 | Flash | 1088kB | 40kB | 8 | 16 | Yes | 10-bit x 32 | – | 8 | 16-bit x 8 |
| | MB91F467CA* | 144 | 3 to 5 | 96 | 2 | Flash | 1088kB | 64kB | 8 | 14 | – | 10-bit x 24 | – | 8 | 16-bit x 8 |
| | MB91F467DA | 208 | 3 to 5 | 96 | 2 | Flash | 1088kB | 64kB | – | 14 | Yes | 10-bit x 24 | – | 8 | 16-bit x 8 |
| | MB91F465DA* | 208 | 3 to 5 | 96 | 2 | Flash | 544kB | 32kB | 8 | 14 | Yes | 10-bit x 24 | – | 8 | 16-bit x 8 |
| | MB91F469GA | 256 | 3 to 5 | 100 | 2 | Flash | 2112kB | 96kB | 8 | 16 | Yes | 10-bit x 32 | – | 8 | 16-bit x 8 |
| | MB91F465KA | 120 | 3 to 5 | 80 | 2 | Flash | 544kB | 16kB | 4 | 10 | – | 10-bit x 26 | – | 8 | 16-bit x 8 |
| | MB91F463NA | 64 | 3 to 5 | 64 | 1 | Flash | 256kB | 10kB | – | 8 | – | 10-bit x 8 | – | 4 | 16-bit x 4 |
| | MB91F467RA | 178 | 3 to 5 | 75 | 2 | Flash | 1088kB | 40kB | 8 | 16 | Yes | 10-bit x 16 | – | 4 | 16-bit x 4 |
| | MB91F465XA | 100 | 3 to 5 | 100 | 2 | Flash | 544kB | 32kB | 8 | 11 | – | 10-bit x 17 | – | 8 | 16-bit x 6 |
| | MB91470/480 | MB91F475* | 144 | 4 to 5.5 | 80 | 1 | Flash | 256kB | 16kB | – | 10 | Yes | 10-bit x 1 x 12 12-bit x 2 x 4 | – | 2 |
| MB91F478* | | 144 | 4 to 5.5 | 80 | 1 | Flash | 384kB | 24kB | – | 10 | Yes | – | – | 2 | 16-bit x 4 |
| MB91F479* | | 144 | 4 to 5.5 | 80 | 1 | Flash | 512kB | 32kB | – | 10 | Yes | – | – | 2 | 16-bit x 4 |
| MB91F487* | | 100 | 4 to 5.5 | 80 | 1 | Flash | 512kB | 32kB | – | 10 | – | 10-bit x 2 x 4 10-bit x 1 x 10 | – | 2 | 16-bit x 8 |

Note: * Under development.

| Output compare (ch) | Timer PPG timer (ch) | PWM timer (ch) | PWC timer (ch) | Up/Down counter (ch) | FC (ch) | UART/SIO (ch) | CAN (ch/MSG) | USB (ch) | SMC (ch) | LCDC (seg x com) | DMAC (ch) | Note | Evaluation device |
|--|--|--|--|--|---|---|---|--|--|---|---|--|---|
| - | - | 16-bit x 4 | - | - | - | 3/- | - | - | - | - | 8 | DRAM I/F | MB91V101A |
| 16-bit x 4 16-bit x 4 16-bit x 4 | 16-bit x 6 16-bit x 6 16-bit x 6 | - - - | 8-bit x 2 8-bit x 2 8-bit x 2 | 8-bit x 2 8-bit x 2 8-bit x 2 | - - - | 4/- 4/- 4/- | - - - | - - - | - - - | 32 x 4 32 x 4 32 x 4 | - - - | - - - | MB91V230 MB91V230 MB91V230 |
| 16-bit x 6 16-bit x 6 | 16-bit x 8 16-bit x 8 | - - | 16-bit x 2 16-bit x 2 | - - | - - | 3/- 3/- | - - | - - | - - | - - | 5 5 | - - | MB91V260B MB91V260B |
| 16-bit x 6 16-bit x 6 16-bit x 6 | 16-bit x 4 16-bit x 4 16-bit x 4 | - - - | 16-bit x 1 16-bit x 1 16-bit x 1 | - - - | - - - | 2/- 2/- 2/- | - - 1/16 | - - - | - - - | - - - | 5 5 5 | - - - | MB91V265 MB91V265 MB91V265 |
| 16-bit x 8 16-bit x 8 | 16-bit x 8 16-bit x 8 | - - | - - | 8-bit x 2 8-bit x 2 | 3 3 | 7/- 7/- | 1/32 1/32 | - - | - - | - - | 5 5 | LIN USART LIN USART | MB91V280 MB91V280 |
| - - | 16-bit x 4 16-bit x 4 | - - | - - | - - | 2 2 | 3/- 3/- | - - | - - | - - | - - | 5 5 | SDRAM I/F Program Loader | MB91V301A MB91V301A |
| 16-bit x 2 16-bit x 2 16-bit x 2 16-bit x 2 16-bit x 8 16-bit x 8 16-bit x 8 16-bit x 8 | 16-bit x 3 16-bit x 3 16-bit x 3 16-bit x 3 16-bit x 6 16-bit x 6 16-bit x 6 16-bit x 6 | - - - - - - - - | - - - - - - - - | 8-bit x 1 8-bit x 1 8-bit x 1 8-bit x 1 8-bit x 2 8-bit x 2 8-bit x 2 8-bit x 2 | 1 1 1 1 1 1 1 1 | 4/2 4/2 4/2 4/2 5/3 5/3 5/3 5/3 | - - - - - - - - | - - - - - - - - | - - - - - - - - | - - - - - - - - | 5 5 5 5 5 5 5 5 | - - - - - - - - | MB91V350A MB91V350A MB91V350A MB91V350A MB91V350A MB91V350A MB91V350A MB91V350A |
| 16-bit x 4 16-bit x 2 16-bit x 2 16-bit x 2 16-bit x 2 16-bit x 2 16-bit x 2 16-bit x 2 16-bit x 2 | 16-bit x 8 16-bit x 4 16-bit x 8 16-bit x 8 16-bit x 4 16-bit x 8 16-bit x 4 16-bit x 4 16-bit x 8 | 16-bit x 8 - - - - - - - - | - - - - - - - - - | - - - - - - - - - | 1 1 1 1 1 1 1 1 1 | 3/2 2/2 2/2 2/2 1/2 1/2 1/2 1/2 2/2 | 3/16 1/16 2/16 2/16 2/16 2/16 2/16 2/16 2/16 | - - 4 4 - - - - 4 | - - - - - - - - - | - - - - - - - - - | 5 5 5 5 5 5 5 5 5 | Sound generator Sound generator Sound generator Sound generator - - - - Sound generator Sound generator | MB91FV360GA MB91FV360GA MB91FV360GA MB91FV360GA MB91FV360GA MB91FV360GA MB91FV360GA MB91FV360GA MB91FV360GA |
| 16-bit x 4 16-bit x 6 16-bit x 8 16-bit x 4 16-bit x 4 16-bit x 8 16-bit x 8 16-bit x 4 16-bit x 4 16-bit x 4 16-bit x 6 | 16-bit x 8 16-bit x 10 16-bit x 16 16-bit x 12 16-bit x 12 16-bit x 16 16-bit x 12 16-bit x 8 16-bit x 12 16-bit x 8 16-bit x 8 16-bit x 12 | - - - - - - - - - - - - | - - - - - - - - - - - - | - - 2 2 2 4 1 2 2 - - - | 3 1 2 3 3 4 3 2 2 2 1 | 7/- 3/- 7/- 5/- 5/- 8/- 5/- 4/- 7/- 3/- 3/- | 2/32 1/32 6/32 3/32 3/32 6/128 3/32 2/32 2/32 2/32 2/32 | - - - - - - - - - - - - | - - - 6 6 - - - - - - - | - - - - - - - - - - - | 5 5 5 5 5 5 5 5 5 5 5 | LIN USART LIN USART LIN USART LIN USART LIN USART LIN USART LIN USART LIN USART LIN USART LIN USART FlexRay (A+B) LIN SUART | MB91V460 MB91V460 MB91V460 MB91V460 MB91V460 MB91V460 MB91V460 MB91V460 MB91V460 MB91V460 MB91V460 |
| 16-bit x 6 16-bit x 6 16-bit x 6 16-bit x 12 | 16-bit x 4 16-bit x 4 16-bit x 4 16-bit x 8 | - - - - | - - - - | 1 1 1 - | - - - - | 6 6 6 3 | - - - - | - - - - | - - - - | - - - - | 5 5 5 5 | BLDC motor control 1 ch, MAC Unit BLDC motor control 1 ch, MAC Unit BLDC motor control 1 ch, MAC Unit BLDC motor control 2 ch, MAC Unit | MB91FV470 MB91FV470 MB91FV470 MB91FV470 |

Integrated software development environment - **‘SOLUTIONS FOR V’**

Fujitsu’s Softune Workbench offers a development environment integrated with the C/C++ compiler, assembler, linker, debugger and editor.

Softune can be used on its own in the development of embedded software for microcontrollers. Fujitsu’s ‘Solutions for V’ can provide an even more advanced program development environment for designers who need to develop high quality embedded software for example for in-vehicle electrical equipment.

The development environment offered by Solutions for V allows the use of CASE tools, consulting and contracted development with UML (Unified Modeling Language), and state charts in the upstream and downstream phases.

State-transition charts are commonly used in the development of in-vehicle equipment, and Softune enables direct connection to CASE tools such as Statemate MAGNUM, RiMC (Rhapsody in MicroC), and ZIPC.

‘Solutions for V’ tools examples

Upstream Case tool Statemate MAGNUM

I-Logix’s Statemate MAGNUM describes the static structure of a control system using an activity chart, which is an extended version of a data flowchart, and describes the system operation using a state chart. A state chart is an extended state-transition chart that enables the hierarchical deployment of the state, the expression of parallelism, and the expression of time, allowing complex system operations to be described easily.

The tool features high descriptive capability and enables the simulation of a specification model for which the specifications are still incomplete.

Following the confirmation of operation, it can generate a C code able to achieve the same operation as the specifications, and can also execute the C code on a prototype for verification purposes.

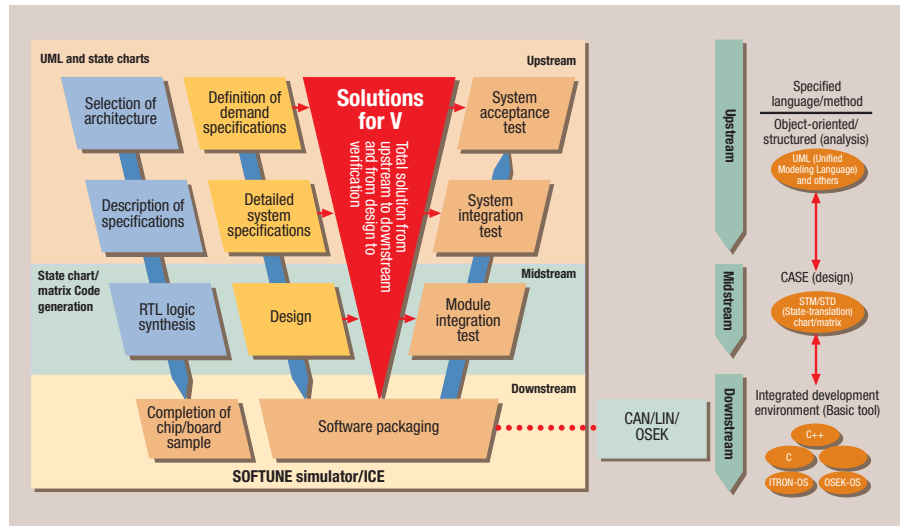

Solutions for V block diagram.



Midstream Case tool ZIPC

ZIPC from CATS CO. LTD. is a CASE tool that supports software development in the midstream stage using ‘Extended-Hierarchy State- Transition-Matrix Design Method Version 2.0.’ By using the state-transition matrix, it enables the creation of designs with no missing data. Because ZIPC is equipped with functions for editing the state-transition matrix, for debugging OSEK, ITRON (REALOS), and others in the design stage, and for automatically generating C-source code, it contributes to the improvement of software quality and reduction of development man-hours.

It uses a converter for linkage to upstream Statemate MAGNUM, and uses state-transition animation and breakpoint setting during C-source generation and debugging for connection to downstream Softune.

SOFTUNE - Fujitsu's integrated software development package

Fujitsu offers its complete range of MCU software tools as part of an integrated package called Softune Workbench, which operates under Windows 95/98, Windows NT4.0, Windows 2000, and Windows XP. This standard package can be used for all Fujitsu MCUs and includes:

- ANSI C/C++ Compiler***
- Macro Assembler**
- Linker**
- Simulator**
- Emulator**
- C/C++ Checker***
- C/C++ Analyser***

* C++ is only available for 32-bit MCUs.

At the user interface, the Softune Workbench provides easy access to all the tools with improved performance and more features. With this, the designer can concentrate on coding and debugging with improved efficiency but without knowledge of how to start the compiler or linker, etc.

Operational features

- Simple menu-based, mouse-driven operations
 - GUI language tools
 - Automatic compiling and linking of associated pre-input files
 - Dialogue boxes to facilitate selection of tool options and project settings
- Automatic start by linking editor, compiler, assembler, linker and debugger
- JError jump to error by simple double click, allowing editor to point automatically to errors
- Selection of built-in editor with syntax highlighting feature, or user's own preferred editor
- On-line compiler and assembler manual help display
- Customisable environment
- Set-up Wizard for debugging environment
- Save / Restore debugging environment

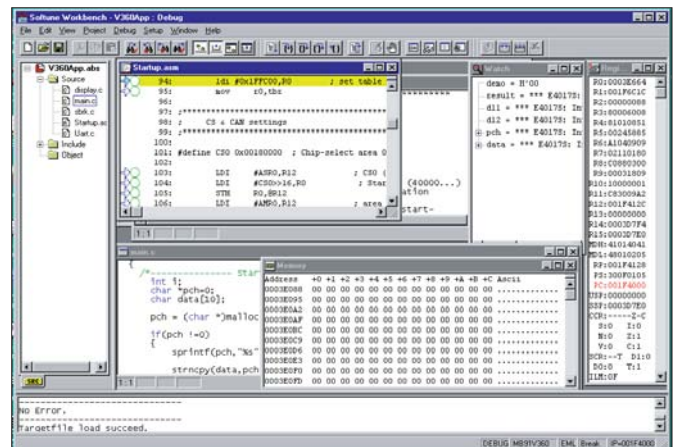

Softune Workbench - user interface Softune GUI simplifies system development.

Debugger features

- Source-level debugging (C, Assembler or Mixed)/files appear as designed
- Breakpoints code/data (6 HW, 65536 SW) possible on every source-line
- Navigate functions: go, go to line, step, step out, step over, call function, reset
- Watch (Variables): automatic update (x sec), format (Hex, Bin, etc.), structures
- View of global and local variables
- Register Window: configurable, updated = red
- Memory Window: format, symbolic edit, direct edit, ASCII
- Dis-assembler Window and in-line assembler
- Trace Window (various display modes) including backtrace function
- Misc: stack follower, time measurement, vector display
- Simulator: I/O-Port stimulus and logging, interrupt simulation
- Tool-control: command input, log-files and batch files

Accemic MDE MONITOR DEBUGGER



Fujitsu Microelectronics offers a monitor debugger for its 16LX and FR series that allows the debugging of single-chip, MCU embedded applications. The Accemic monitor debugger allows downloading of the debugger kernel and the application into the embedded flash memory of the MCU. The monitor kernel can be started directly to load new programs and execute them under control. There is also the option to start the user application directly after reset and enter debug mode on demand.

A special feature of this debugger is the processor status window, which shows all internal peripherals of the MCU, including pin status and direction. Detailed peripheral windows allow the user to check and modify peripheral settings. Beside the usual available debug functionalities, on-line monitoring, powerful messaging functions can be linked to the application in order to send data and messages to the PC screen.

As well as a standard version, a professional version is also available, offering more powerful features. This version supports up to 16 breakpoints and the multiprocessor/multicore debugging feature allows different processors in a CAN network to be controlled at the same time. With the Accemic HSCI option several communication channels to the target MCU can be used: CAN, UART asynchronous mode, UART synchronous mode and emulation of serial communication via free I/O ports.

Accemic is a Munich-based third party supplier to Fujitsu.

A demonstration version of the Accemic MDE can be downloaded from the Fujitsu Microelectronics Europe web-site (www.fme.gsdc.de/gsd.c.htm) or the Accemic (www.accemic.com) web site.

Main features

- Memory usage
 - ROM: 8kByte monitor kernel size + 256Byte configuration data
 - RAM: 128Byte used by kernel
- Two hardware breakpoints
- Single step, step-in, step-out, step-over functions
- CALL function
- Target message Window
- Debugging on C-Source code or Assembler level
- Dedicated Debug Windows
 - Source Window
 - Mixed mode view for C-Source and Assembler view
 - Watch Window
 - Memory Window
 - Stack Window
 - Interrupt vector table
 - CPU core register Window
 - Peripheral status Window
 - Processor status Window shows register contents of the internal MCU peripherals
- Browser Window
 - Interrupts, Functions, Units, Local/Global Variables, I/ORegisters
- On-line help
- Supported devices:
 - MB90330 & MB90340 series
 - MB90350 & MB90385 series
 - MB90390 & MB90425 series
 - MB90435 & MB90455 series
 - MB90460 & MB90470 series
 - MB90495 & MB90520 series
 - MB90540/545 series
 - MB90560/565 series
 - MB90570 & MB90580 series
 - MB90590/595 series
 - MB90800 & MB90820 series
 - MB90945 series
 - MB91350 Series, MB91270 series
 - MB91F364G, MB91F376G series
 - MB91460 series

Debugger order numbers - MonDebugger16LX-ACC. and MonDebuggerFR-ACC for 16-bit and 32-bit MCUs see the related web page.

Accemic GmbH & Co. KG

Würzstraße 1, 81371 Munich, Germany
Tel: +49 89 680934-0 Fax: +49 89 680934-27
Email: info@accemic.com Web: www.accemic.com

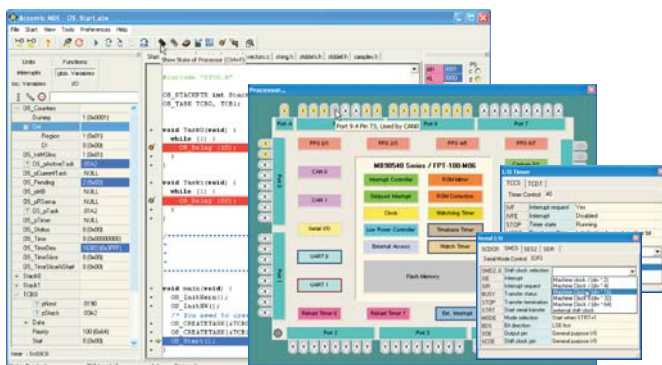

Galep IV universal serial/parallel **MCU PROGRAMMER**

Conitec's new fourth generation GALEP IV is a professional palm-sized field programmer with universal I/O capability. It supports almost all Fujitsu Microcontrollers of F²MC-8L, F²MC-16LX and FR families.

Galep IV uses a highly integrated FPGA and each socket pin carries a separate universal pin-driver. Via special programming adapters, Fujitsu MCUs can be programmed parallel or serial in-circuit (ISP). For serial in-circuit programming both serial synchronous (high speed) and asynchronous programming via RS232 is supported.

Features

- Unlimited free software updates via Internet
- Editor included, Load and Save in binary, intel-hex, motorola-s or Jedec file formats.
- Dual power: AC adapter or intern. batteries: 6 rechargeable NiMH batteries (AAA/600mAh.)
- Socket converters available for most component packages
- Support for low voltage devices down to 1.3V
- Pocket-sized, ultra-portable format: only 80 x 115 x 33mm
- Simple PC printer port connection
- Supports ISP programming
- Supports remote control
- Allows design of own software programming interface by offering API interface
- Supports autoprogram mode via batchfile execution

Galep IV – ISP adapter

- Supports Fujitsu 8L, 16LX and FR series
- Target power supply by Galep(max 200mA) or external source selectable
- Target system control signals provided (Target Control Connector) v flexible design provides for easy implementation of future devices

System requirements

- Pentium processor
 - 32-bit Windows OS (Win95 /98 /ME /NT4 /2000 /XP)



GALEP IV is a professional palm-sized field programmer with universal I/O capability.



Contact

Conitec Datensysteme GmbH
 Dieselstrasse 11c
 D-64807 Dieburg
 Germany
 Tel: +49-6071-9252-0
 Fax:+49-6071-9252-33
 galep@conitec.com
 www.conitec.net/

Real-time **OPERATING SYSTEMS**

OSEK/VDX OS targeted for automotive applications

OSEK/VDX is an operating system targeted for automotive applications. It consists of three parts, the OSEK kernel, the communications interface and the network management. Mainly automotive controller networks using CAN interfaces will employ the OSEK operating system. The FR series of microcontrollers is supported with optimised drivers for the Fujitsu CAN controller.

OSEK-OS defines the task types 'Basic' and 'Extended'. Basic tasks cannot have a waiting state and so are suitable for those which run completely after each activation. Extended tasks can react to events; they can have a waiting state. OSEK-OS also defines four conformance classes:

- BCC1 – basic tasks, single activation
- BCC2 – basic tasks, multiple activation
- ECC1 – basic and extended tasks, single activation
- ECC2 – basic and extended tasks, multiple activation

The FR series OSEK without CAN driver and network management requires 3.2kB ROM for class ECC1 (standard status)

Further information: www.vector-informatic.com

embOS OS targeted for embedded applications

embOS* is a real-time operating system for embedded applications designed to offer the benefits of a fully featured multi-tasking system even for hard real-time applications using minimal resources.

All functions of embOS have been placed in individual modules to ensure that only the functions needed are actually linked into the application program, leaving maximum room for the user-program.

Features

- Pre-emptive multi-tasking
- Priority-controlled scheduling
- Round robin scheduling
- Intertask communication
- Software timer
- Minimum interrupt latency
- Fast & efficient
- Small footprint (can be used in single-chip mode)
- Easy-to-use start project
- Versatile
- Support directly by developers
- System analysis via UART
- Profiling support
- TCP/IP - and other network stacks available

Developing applications with embOS

embOS is available in source or object code form. Both come with a ready to go start project:

The first multi-task program is running within five minutes. The start application and usable samples are supplied in source code form. Libraries for all memory models and initialisation of the controller in 'C'-source are included to tailor the system to any application.

Check out the free full-functional trial version, which can be downloaded from the website: www.segger.com

TCP/IP stacks for embOS

As connectivity and Internet became a major issue even in embedded systems, embOS is designed to support TCP/IP and other network stacks. We offer a fully-featured, 100% RFC-compliant TCP/IP stack, that runs on any supported 16- or 32-bit target CPU. It provides virtually all of the protocols, link layers, interfaces and device drivers that are required for networking connectivity applications.

*embOS is a product of Segger



www.segger.de

EUROS Enhanced Universal Real-Time Operating System

EUROS is an innovative real-time operating system characterised by short response times, robustness, scalability and flexibility. The primary aim of EUROS development was to create a uniform, hardware-independent operating system for real-time and embedded applications, which takes into account the growing complexity and diversity of processor architectures, in order to make software engineering as economical as possible. It separates the user software from the hardware so that the application can easily be ported to state-of-the-art hardware.

Key features

- Supports Fujitsu F²MC-16LX and FR series
- Unlimited number of system objects (tasks, mailboxes, signals, events, semaphores, drivers)
- Up to 256 priorities
- Synchronous and asynchronous system calls
- Memory management supports fixed and variable size memory blocks
- Waiting on multiple objects
- Flexible open driver interface
- Priority-based scheduler with round robin support
- Named system objects organised in clusters (hierarchical object trees)
- Re-entrant ANSI compatible C runtime library
- Generic graphic library
- TCP/IP network stack (BSD4.4 socket interface)
- Web server, FTP server, SMTP client, BOOTP client
- PPP, Ethernet
- CAN / CANopen
- MS-DOS™ compatible file system
- IDE hard disk drivers
- Floppy disk drivers
- Ramdisk, FTL for Flashdisks
- IrDA (IrLAP, IrLMP, IrComm)
- Profibus (slave)
- IEEE1394 (Firewire)

EUROSvm Euros Virtual Machine

EUROSvm is an implementation of the Java Virtual Machine Specification V1.2. It has been designed for real-time and embedded systems and offers unparalleled support for this target domain. Among the extraordinary features of EUROSvm are:

- Hard real-time execution
- Minimal footprint
- ROMable code
- Native code support
- Dynamic linking
- Fast execution

Contact information

Dr. Kaneff Engineering Consultants,
 Campestraße 12
 D-90419 Nuremberg, Germany
 Tel: +49 (911) 33 84 33
 Fax: +49 (911) 33 86 06
www.kaneff.de
info@kaneff.de



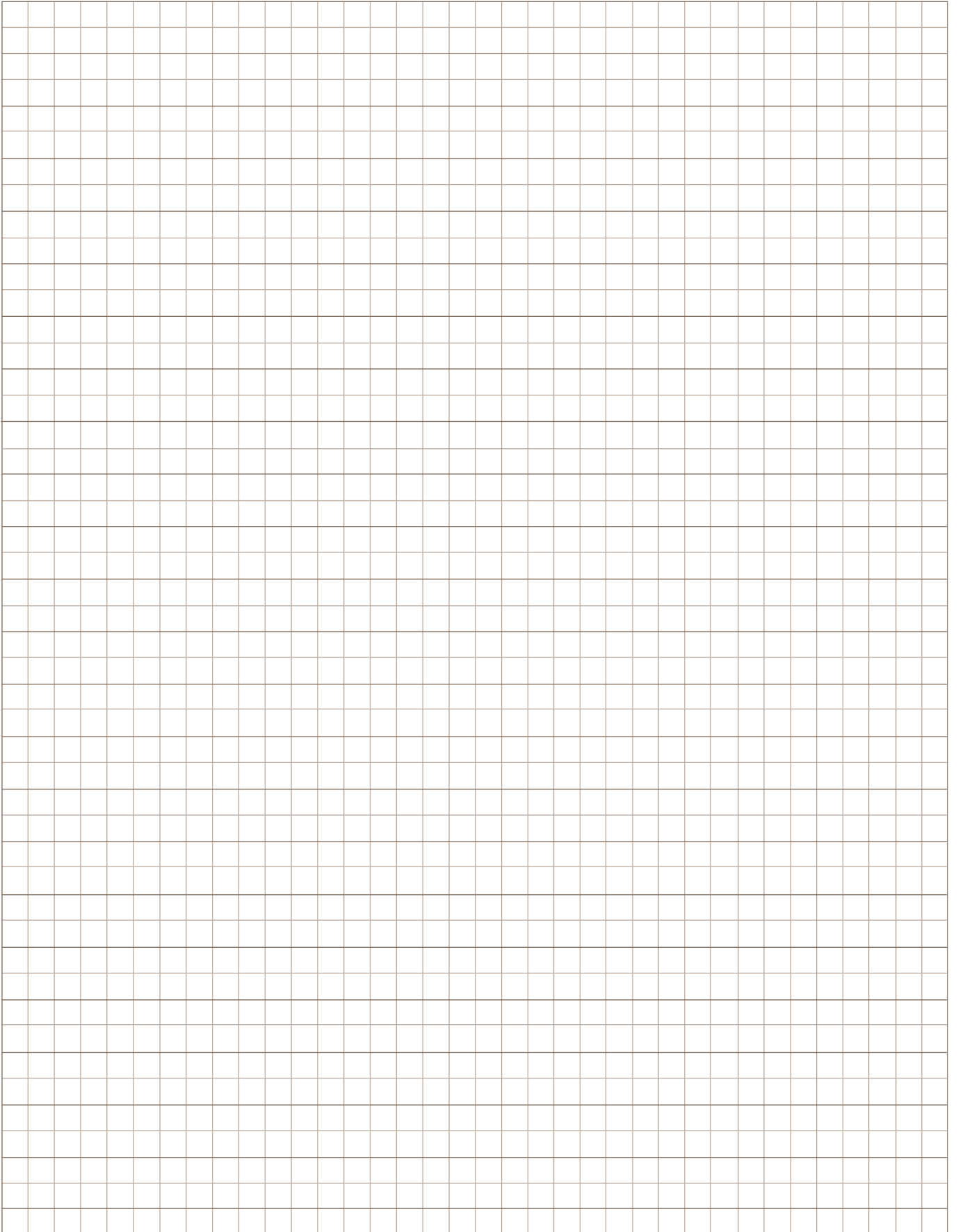

PRODUCT OVERVIEW MICROCONTROLLERS

EMEA Distributors

Austria

EBV Elektronik
Diefenbachgasse 35/1M, A-1150 Vienna
Tel: +43 (0)1 891 52-0
Fax: +43 (0)1 891 52-30

Glyn & Co. KG
Campus 21 / Businesspark Wien Süd
Liebermannstrasse A102 / 301
A-2345 Brunn am Gebirge
Tel: +43 (0)1 86670 214 00
Fax: +43 (0)1 86670 214 05

ATeG-Ineltek
Wagramer Strasse 126/21
A-1220 Wien
Tel: +43 (0)1 204 98 38 0
Fax: +43 (0)1 204 90 38

Rutronik Elektronische Bauelemente
Durisolstrasse 7
A-4600 Wels
Tel: +43 (0) 72 42/4 49 01
Fax: +43 (0) 72 42/4 49 01 33

Rutronik Elektronische Bauelemente
Waidhausenstrasse 19, Top 10
A-1140 Wien
Tel: +43 (0) 1/4 19 65 50
Fax: +43 (0) 1/4 19 65 50 33

Belgium

EBV Elektronik
Kouterveldstraat 20, B-1831 Diegem
Tel: +32 (0)2 716 00 10
Fax: +32 (0)2 720 81 52

Rutronik Elektronische Bauelemente
Place-Rooseveltplein, 1/B11
B-9600 Ronse-Renaix
Tel: +32 (0) 55 20 74 63
Fax: +32 (0) 55 20 98 05

Bulgaria

Rutronik Elektronische Bauelemente
ul. Cherkovna No.57, Büro No.16
BG-1505 Sofia
Tel: +359 2 9430330
Fax: +359 2 9430331

Czech Republic

EBV Elektronik
Argentinska 38 / 286, CZ-170 00 Praha 7
Tel: +420 234 091 011
Fax: +420 234 091 010

Rutronik Elektronische Bauelemente
CZ spol.s.r.o., Rooseveltova 13
CZ-160 00 Praha 6
Tel: +420 233 343 120
Fax: +420 233 323 955

Rutronik Elektronische Bauelemente
CZ spol.s.r.o., Slavickova 1a
CZ-63800 Brno
Tel: +420 (0) 5/45 19 35 17
Fax: +420 (0) 5/45 22 22 56

Denmark

EBV Elektronik
Rosenkærret 11 C, DK-2860 Søborg
Tel: +45 39 69 05 11
Fax: +45 39 69 05 04

EBV Elektronik
Ved Lunden 9, DK-8230 Aabyhøj
Tel: +45 86 25 04 66
Fax: +45 86 25 06 60

Rutronik Elektronische Bauelemente
Farum Gydevej 63
DK-3520 Farum
Tel: +45 70 20 19 63
Fax: +45 70 20 19 73

Estonia

EBV Elektronik
Laki 12, EE-10621 Tallinn
Tel: +372 683 38 66
Fax: +372 683 38 70
Mobile: +372 513 22 32

Finland

EBV Elektronik
Pihatörmä 1 a, FIN-02240 Espoo
Tel: +358 (0)9 27 05 27 90
Fax: +358 (0)9 27 09 54 98

EBV Elektronik
Nahkatehtaankatu 2, FIN-90100 Oulu
Tel: +358 (0)8 562 49 10
Fax: +358 (0)8 562 49 15

France

EBV Elektronik
115, Rue Nicolas Ledoux
Immeuble Hemiris, Bâtiment A
F-13854 Aix-en-Provence Cedex 3
Tel: +33 (0)4 42 39 65 40
Fax: +33 (0)4 42 39 65 50

EBV Elektronik
Immeuble Actys B2, voie 3
BP17316
F-31673 Labège Cedex (Toulouse)
Tel: +33 (0)5 61 00 84 61
Fax: +33 (0)5 61 00 84 74

EBV Elektronik
29, Avenue des Peupliers
F-35510 Cesson Sévigné (Rennes)
Tel: +33 (0)2 99 83 00 50
Fax: +33 (0)2 99 83 00 60

EBV Elektronik
Parc Club du Moulin à Vent,
33, Av. du Dr. Georges Lévy
F-69693 Venissieux Cedex (Lyon)
Tel: +33 (0)4 72 78 02 78
Fax: +33 (0)4 78 00 80 81

EBV Elektronik
3, Rue de la Renaissance
F-92184 Antony Cedex (Paris)
Tel: +33 (0)1 40 96 30 00
Fax: +33 (0)1 40 96 30 30

EBV Elektronik
Parc d'innovation d'Illkirch
Rue Gruninger
F-67400 Illkirch Graffenstaden (Strasbourg)
Tel: +33 (0)3 90 40 59 69
Fax: +33 (0)3 88 65 11 25

PN Electronics
142-176 avenue de Stalingrad
Parc Technologique des Corvettes BP 53
F-92703 Colombes Cedex
Tel: +33 (0)1 47 80 67 85
Fax: +33 (0)1 47 85 95 12

PN Electronics
Rue Jean Bart
Immeuble Calliope
F-31317 Labège
Tel: +33 (0)5 62 88 23 23
Fax: +33 (0)5 62 88 23 29

PN Electronics
13, impasse des Cerisiers
F-67580 Laubach
Tel: +33 (0)3 88 90 43 48
Fax: +33 (0)3 88 90 37 11

PN Electronics
334 Rue des vingt toises-Le Magistere II
F-38950 Saint Martin le Vinoux
Tel: +33 (0)4 38 02 02 03
Fax: +33 (0)4 38 02 21 00

Rutronik SA
Avenue Gustave Eiffel ZI BP 81
F-33605 Pessac, Cedex (Bordeaux)
Tel: +33 (0) 5/57 26 40 00
Fax: +33 (0) 5/56 07 64 41

Rutronik SA
6 Mail de l'Europe
F-78170 La Celle St Cloud, (Gecodis)
Tel: +33 (0) 1/30 08 33 26
Fax: +33 (0) 1/30 08 33 29

Rutronik SA
3 Allée des Centaurées Le Royal II
F-38240 Meylan, (Grenoble)
Tel: +33 (0) 4/76 61 00 90
Fax: +33 (0) 4/76 61 00 99

Rutronik SA
1, Impasse René Lebrun
F-72000 Le Mans
Tel: +33 (0) 2/43 78 16 97
Fax: +33 (0) 2/43 78 19 12

Rutronik SA
6, impasse Michel Labrousse BP 1305
F-31106 Toulouse
Tel: +33 (0) 5/61 40 96 50
Fax: +33 (0) 5/61 41 75 49

Rutronik SA
11, rue du TaninLingolsheim PB 109
F-67883 - Tanneries, Cedex (Strasbourg)
Tel: +33 (0) 3/88 78 12 12
Fax: +33 (0) 3/88 78 02 20

Rutronik SA

170, Avenue Jean-Jaurès BP 7113
F-69353 Lyon, Cedex 07 (Lyon)
Tel: +33 (0) 4/72 76 80 00
Fax: +33 (0) 4/72 76 80 05

Rutronik SA
6 Mail de l'Europe
F-78170 La Celle St Cloud
(Paris Ile de France)
Tel: +33 (0) 1/30 08 34 40
Fax: +33 (0) 1/30 08 34 37

Rutronik SA
Allée de la Détente BP16 ZI
F-86361 Chasseneuil du Poitou
Cedex (Poitiers)
Tel: +33 (0) 5/49 52 88 88
Fax: +33 (0) 5/49 52 88 96

Rutronik SA
3D rue de ParisImmeuble Atalis 2
F-35510 Cesson Sévigné, (Rennes)
Tel: +33 (0) 2/23 45 14 40
Fax: +33 (0) 2/ 23 45 06 53

Germany

EBV Elektronik
Zum Mühlenberg 9
D-07806 Neustadt / Orla
Tel: +49 (0)36481 244-0
Fax: +49 (0)36481 244-99

EBV Elektronik
Kitzingstr. 15-19
D-12277 Berlin-Mariendorf
Tel: +49 (0)30 74 70 05-0
Fax: +49 (0)30 74 70 05-55

EBV Elektronik
In der Meineworth 21
D-30938 Burgwedel
Tel: +49 (0)5139 80 87-0
Fax: +49 (0)5139 80 87-70

EBV Elektronik
An der Guempgesbruecke 7
D-41564 Kaarst
Tel: +49 (0)2131 96 77-0
Fax: +49 (0)2131 96 77-30

EBV Elektronik
Borsigstr. 36
D-65205 Wiesbaden
Tel: +49 (0)6122 80 88-0
Fax: +49 (0)6122 80 88 99

EBV Elektronik
Neue Ramtelstrasse 4
D-71229 Leonberg
Tel: +49 (0)7152 30 09-0
Fax: +49 (0)7152 759 58

EBV Elektronik
Im Technologiepark 2-8
D-85586 Poing
Tel: +49 (0)8121 774-0
Fax: +49 (0)8121 774-422

EBV Elektronik
Kaiserring 12
D-78050 VS-Villingen
Tel: +49 (0) 7721 99857-0
Fax: +49 (0) 7721 99857-70

Glyn & Co. KG
Am Wörtzgarten 8
D-65510 Idstein/Ts.
Tel: +49 (0)6126 59 02 22
Fax: +49 (0)6126 59 01 11

Glyn & Co.KG
Ringstrasse 88
D-41334 Nettetal
Tel: +49 (0)2157 12 42 25
Fax: +49 (0)2157 12 42 11

ATeG-Ineltek (Headquarters)
Hauptstraße 45
D-89522 Heidenheim
Tel: +49 (0)7321 93 85 0
Fax: +49 (0)7321 93 85 95

ATeG-Ineltek Nord
Lindenallee 84
D-22869 Schenefeld
Tel: +49 (0)4083 96 04 0
Fax: +49 (0)4083 96 04 33

ATeG-Ineltek Mitte
Hauptstr. 13
D-63834 Sulzbach
Tel: +49 (0)6028 99 38 0
Fax: +49 (0)6028 99 38 38

ATeG-Ineltek Süd
Am Fügsee 21
D-82418 Murnau
Tel: +49 (0)8841 47 77 5
Fax: +49 (0)8841 26 60

ATeG-Ineltek GmbH Erfurt
Geraerstr. 33
D-99099 Erfurt
Tel: +49 (0)361 34 64 28 0
Fax: +49 (0)361 34 64 28 1

Rutronik Elektronische Bauelemente
Head office
Industriestrasse 2
D-75228 Ispringen
Tel: +49 (0) 72 31/801-0
Fax: +49 (0) 72 31/82282

Rutronik Elektronische Bauelemente
Falkenberg ParkParadiesstrasse 206 b
D-12526 Berlin
Tel: +49 (0) 30/72 32 08-93
Fax: +49 (0) 30/72 32 08-95

Rutronik Elektronische Bauelemente
Beratgerstrasse 36
D-44149 Dortmund
Tel: +49 (0) 2 31/9 50 36-0
Fax: +49 (0) 2 31/9 50 36-31

Rutronik Elektronische Bauelemente
Mittelstrasse 3
D-01936 Königsbrück (Dresden)
Tel: +49 (0)3 57 95/3 96-0
Fax: +49 (0)3 57 95/3 96-50

Rutronik Elektronische Bauelemente
Flughafenstrasse 4
D-99092 Erfurt
Tel: +49 (0) 3 61/2 28 36 30
Fax: +49 (0) 3 61/2 28 36 31

Rutronik Elektronische Bauelemente
Heinz-Beusen-Stieg 5
D-22926 Ahrensburg (Hamburg)
Tel: +49 (0) 41 02/80 39-0
Fax: +49 (0) 41 02/80 39-50

Rutronik Elektronische Bauelemente
Amstelstrasse 33
D-68307 Mannheim
Tel: +49 (0)621/ 76 21 26-0
Fax: +49 (0)621/ 76 21 26-17

Rutronik Elektronische Bauelemente
Lilly-Reich-Strasse 7
D-31137 Hildesheim
Tel: +49 (0) 51 21/74 18-0
Fax: +49 (0) 51 21/74 18-18

Rutronik Elektronische Bauelemente
Landsberger Strasse 478
D-81241 München
Tel: +49 (0) 89/88 99 91-0
Fax: +49 (0) 89/88 99 91-19

Rutronik Elektronische Bauelemente
Südwestpark 10/12
D-90449 Nürnberg
Tel: +49 (0)9 11/6 88 68-0
Fax: +49 (0)9 11/6 88 68-90

Rutronik Elektronische Bauelemente
Gothaer Strasse 2
D-40880 Ratingen
Tel: +49 (0) 21 02/99 00-0
Fax: +49 (0) 21 02/99 00-19

Greece

EBV Elektronik
1, Anaxagora Str.
GR-17778 Tavros (Athens)
Tel: +30 210 34 14 300
Fax: +30 210 34 14 304

Hungary

EBV Elektronik
Montevideo u. 2/B
H-1037 Budapest
Tel: +36 1 436-72-29
Fax: +36 1 436-72-20

Ineltek Hungary Kft.
Madach ter 4
H-1071 Budapest
Tel: +36 1 327 84 07
Fax: +36 1 327 84 43

Rutronik Magyarország Kft
Fehérvári út 89-95
H-1119 Budapest
Tel: +36 (0)1/371 06 66
Fax: +36 (0)1/371 06 67

Ireland
EBV Elektronik
Ballymount Trading Estate
Ballymount Road, Walkinstown
IRL - Dublin 12
Tel: +353 (0)1 456 4034
Fax: +353 (0)1 456 4035

Rutronik Ltd
Ormeau Business Park
Unit 258
Cromac Avenue
Belfast BT7 2JA
Tel: +44 28 90 87 10 00
Fax: +44 28 90 87 10 01

Israel
EBV Elektronik
Drorrim South Commercial Center
(Avnet building), P.O. Box 149
IL - 40600 Tel Mond
Tel: +972 (0)9 778 02 60
Fax: +972 (0)9 796 68 80

Italy
EBV Elektronik
Viale Palmiro Togliatti 1639
I-00155 Roma
Tel: +39 06 40 63 665/789
Fax: +39 06 40 63 777

EBV Elektronik
Corso Vercelli, 348
I-10156 Torino
Tel: +39 011 262 56 90
Fax: +39 011 262 56 91

EBV Elektronik
Via C. Frova, 34
I-20092 Cinisello - Balsamo (MI)
Tel: +39 02 66 09 62 90
Fax: +39 02 66 01 70 20

EBV Elektronik
Piazza Adelaide Lonigo , 8/11
I-35030 Sarmeola di Rubano (PD)
Tel: +39 049 89 74 701
Fax: +39 049 89 74 726

EBV Elektronik
Via Campagna, 12
I-41010 Cognetto (MO)
Tel: +39 059 2924 211
Fax: +39 059 2929 486

EBV Elektronik
Via Panciatici, 40
Palazzo 11
I-50127 Firenze
Tel: +39 055 43 69 307
Fax: +39 055 42 65 240

EBV Elektronik
Via G. Capaldo, 10
I-80128 Napoli
Tel: +39 081 579 977 0
Mobile: +39 335 839 05 31

Malpassi s.r.l.
Via Baravelli 1
I-40012 Calderara di Reno Bologna
Tel: +39 051 72 72 52
Fax: +39 051 72 73 78

Melchioni Electronica S.p.A.
Divisione Industria
Via Pietro Colletta 37
I-20135 Milano
Tel: +39 025 79 43 54
Fax: +39 025 41 34 001

Rutronik Italia S.r.l.
Via Caldera, 21, Centro Direzionale S.Siro
I-20153 Milano (MI)
Tel: +39 02 40 951 1
Fax: +39 02 40 951 224

Rutronik Italia S.r.l.
Viale Togliatti, 25, I-40133 Bologna (BO)
Tel: +39 051 351 94 00
Fax: +39 051 351 94 90

Rutronik Italia S.r.l.
Via V. Emanuele, 33, I-50041 Calenzano (FI)
Tel: +39 055 88 27 332
Fax: +39 055 88 10 364

Rutronik Italia S.r.l.
Via Arcora, 110 - Palazzo Gecos
I-80013 Casalnuovo di Napoli (NA)
Tel: +39 081 52 28 709
Fax: +39 051 31 75 131

Rutronik Italia S.r.l.
Via Savelli, 62, I-35129 Padova (PD)
Tel: +39 049 86 978 00
Fax: +39 049 86 978 90

Rutronik Italia S.r.l.
Via Del Maggiolino, 125, I-00155 Roma (RO)
Tel: +39 06 228 782 1
Fax: +39 06 228 782 689

Rutronik Italia S.r.l.
Strada Torino, 43/45 Europalace
I-10043 Orbassano (TO)
Tel: +39 011 90 220 00
Fax: +39 011 90 63 913

Netherlands
EBV Elektronik
Planetenbaan 116
NL-3606 AK Maarssenbroek
Tel: +31 (0)346 58 30 10
Fax: +31 (0)346 58 30 25

Glyn Benelux
Waalresegew 17
NL-5554 HA Valkenswaard, Niederlande
Tel: +32 (0)1 402 04 97 00
Fax: +32 (0)1 402 04 97 84

Rutronik Elektronische Bauelemente
Madame Curiestraat 2
NL-3316 GN Dordrecht
Tel: +31 (0) 78/6 52 13 80
Fax: +31 (0) 78/6 52 13 81

Norway
EBV Elektronik
Ryensvingen 3 B PO Box 101
Manglerud, N-0612 Oslo
Tel: +47 22 67 17 80
Fax: +47 22 67 17 89

Poland
EBV Elektronik
Plac Solny 16, PL-50-062 Wrocław
Tel: +48 (0)71 34 229 44
Fax: +48 (0)71 34 229 10

EBV Elektronik
ul. Domaniewska 39A
PL-02-672 Warszawa
Tel: +48 (0) 22 640 23 55
Fax: +48 (0) 22 640 23 56

Rutronik Polska Sp. z o.o.
ul. Sasiedzka 11
PL-44244 Zory
Tel: +48 32/4 75 90-20
Fax: +48 32/ 4 75 90-22

Rutronik Polska Sp. z o.o.
ul. Batorego 28-32
PL-481-366 Gdynia
Tel: +48 (0) 58 / 783 20 - 20
Fax: +48 (0) 58 / 783 20 ? 22

Russia
EBV Elektronik
Korovinskoye Chaussee 10
Build 2, Off. 28
RUS-127486 Moscow
Tel: +7 (495) 937 87 07
Fax: +7 (495) 937 87 06

ATeG-Ineltek Russia
Kutovsky Prospect 14, Building 1, Office 30
RUS-121248 Moscow, Russia
Tel: +7 (0)95 101 89 70
Fax: +7 (0)95 326 69 50

Rutronik Beteiligungsgesellschaft mbH
Haus 3, Büro 403, Leningradskoje Chaussee 16
RUS-125171 Moscow
Tel: +7 (0) 9 51 59 92 55

Slovenia
EBV Elektronik s.r.o.
Digital Park
Einsteinova 21
SK - 85101 Bratislava
Slovak Republic
Tel: +421 2 321 111 41
Fax: +421 2 321 111 40

EBV Elektronik
Dunajska cesta 159
SL-1000 Ljubljana
Tel: +386 (0)1 5609 778
Fax: +386 (0)1 56 09 877

South Africa
EBV Elektronik
Woodlands Office Park
141 Western Service Road
Building 14-2nd Floor
ZA - 2157 Woodmead, Johannesburg
Tel: +27 (0) 11 236 19 00
Fax: +27 (0) 11 236 19 13

EBV Elektronik
1 Mediterranean Street, 5th Floor MSC House
ZA - 8001 Foreshore, Cape Town
Tel: +27 (0) 21 402 19 40
Fax: +27 (0) 21 419 62 56

EBV Elektronik
236 Queen Mary Ave
ZA - Glenmore, Durban 4001
Tel: +27 (0)31 205-1205
Fax: +27 (0)31 205-2265

Spain
EBV Elektronik
Anton Fortuny, 14-16 Esc C 3o 2a
E-08950 Esplugues de Llobregat (Barcelona)
Tel: +34 93 473 32 00
Fax: +34 93 473 63 89

EBV Elektronik
C/Ronda de Poniente, 4
Centro Empresarial Euronova
E-28760 Tres Cantos / Madrid
Tel: +34 91 804 32 56
Fax: +34 91 804 41 03

Rutronik Espana S.L
Ctra. Canillas 138 - 2a Planta - 9B
E-28043 Madrid
Tel: +34 91/300 55 28
Fax: +34 91/300 53 28

Rutronik Espana S.L
Avda. Constitucion Nr. 171, Entlo 3, Esc.B
E-08860 Castelldefels, (Barcelona)
Tel: +34/93/664 62 04
Fax: +34/93/664 62 05

Sagitron
C/ Montón de Trigo 2,
esq. avda. de la Industria
E-28760 Tres Cantos , Madrid
Tel: +34 91 8 06 38 00
Fax: +34 91 8 06 38 05

Sweden
EBV Elektronik
Sjöängsvägen 7, S-19272 Sollentuna
Tel: +46 (0)8 59 47 02 30
Fax: +46 (0)8 59 47 02 31

EBV Elektronik
Derbyvägen 20, S-21235 Malmö
Tel: +46 (0)40 59 21 00
Fax: +46 (0)40 59 21 01

Switzerland
Anatec AG
Sumpfstrasse 7, CH-6300 Zug
Tel: +41 (0)4 748 32 32
Fax: +41 (0)4 748 32 31

EBV Elektronik
Av. des Boveresses 52, CH-1010 Lausanne
Tel: +41 (0)21 654 01 01
Fax: +41 (0)21 654 01 00

EBV Elektronik
Bernstrasse 394, CH-8953 Dietikon
Tel: +41 (0) 44 745 61 61
Fax: +41 (0) 44 745 61 00

Rutronik Elektronische Bauelemente AG
Höhlwisenstrasse 5
CH-8604 Volketswil
Tel: +41 (0) 1/947 37 37
Fax: +41 (0) 1/947 37 47

Turkey
EBV Elektronik
Bayar Caddesi, Gülbahar Sok. No:17
Perdemaşç Plaza,
13th Floor, D:134
Kozyatagi, TR-34742 Istanbul
Tel: +90 (0)216 463 13 52
Fax: +90 (0)216 463 13 55

Ukraine
EBV Elektronik
Vasilkovskaya str. 14
off. 422-423
UA-03040 Kiev
Tel: +380 44 496 22 26
Fax: +380 44 496 22 27

United Arab Emirates
EBV Elektronik
Warehouse No : FZS1AL06
JAFZA South Zone
Jebel Ali, Dubai, United Arab Emirates
Post Box No. 18657
Tel: +971 4 886 09 50
Fax: +971 4 886 09 52

United Kingdom
EBV Elektronik
EBV House, 7 Frascati Way
Maidenhead, Berkshire, SL6 4UY
Tel: +44 (0)1628 770 707
Fax: +44 (0)1628 783 811

EBV Elektronik
144 West George Street
Glasgow, G2 2HG
Tel: +44 (0)141 352 20 50
Fax: +44 (0)141 352 20 59

EBV Elektronik
Manchester International Office
Centre Suite 5B, Styal Road
Manchester, M22 5WB
Tel: +44 (0)161 499 34 34
Fax: +44 (0)161 499 34 74

EBV Elektronik
12 Interface Business Park
Bincknoll Lane, Wootton Bassett
Wiltshire, SN4 8SY
Tel: +44 (0)1793 849 933
Fax: +44 (0)1793 859 555

Rutronik UK Ltd
Dunscar House
Deakins Business Park
Blackburn Road, Egerton
Bolton, BL7 9RP
Tel: +44 (0) 12 04 60 22 00
Fax: +44 (0) 12 04 60 22 10

Web Sites

Anatec AG:
www.anatec.ch

EBV Elektronik GmbH:
www.ebv.com

Glyn GmbH & Co. KG:
www.glyn.de

ATeG Ineltek GmbH:
www.ineltek.de

Malpassi srl:
www.malpassi.it

Melchioni Electronica SpA:
www.melchioni.it

PN Electronics:
www.pne.fr

Rutronik:
www.rutronik.com

Sagitron:
www.sagitron.es



ASK FUJITSU

Contact us on +49(0) 61 03 69 00 or visit
<http://emea.fujitsu.com/microelectronics>