



Sentinel 300P series

Automatic switch mode battery chargers

Installation, Operation & Maintenance

This manual refers to the following models

All models are UL recognised or listed			
Open frame models	SNTL300P SNTL300PC	Base open-frame (protective cover) model. As above, plus CAN J1939 communication.	CE cRU®
Enclosed models	ESNTL300PM ESNTL300PCL ESNTL300PCLM	Enclosed model, analogue meters. Enclosed model, CAN J1939 communications and LCD display Enclosed model, CAN J1939 communications, LCD display and analogue meters.	CE cUL US



For safe and correct use of these chargers, read and save the safety information that precedes the installation and operation instructions.

This guide contains 12 pages (including this one). If any pages are missing, contact the battery charger supplier or manufacturer for replacement documentation.



Sentinel 300P (open-frame, with protective cover)
SNTL300P model shown



Enclosed Sentinel 300P
ESNTL300PCLM model shown

COMPUTRONIC CONTROLS

by **ENOVATION CONTROLS**

41 - 46 Railway Terrace, Nechells,
Birmingham, B7 5NG, United Kingdom
Web: www.computroniccontrols.com

For sales & support, contact:

ENOVATION CONTROLS LTD.
Church Road, Laverstock,
Salisbury, SP1 1QZ, United Kingdom
Phone: +44 1722 410055
Fax: +44 1722 410088
E-mail: sales@novationcontrols.eu
Web: www.computroniccontrols.com
www.fwmurphy.eu/computronic

ENOVATION CONTROLS
5311 S 122nd East Avenue,
Tulsa, OK 74146, USA
Phone: +1 918 317 4100
Fax: +1 918 317 4266
E-mail: sales@fwmurphy.com
Web: www.fwmurphy.com

Important Safety Information – Read and Save These Instructions

This manual contains important safety and operating instructions for all SNTL300P and ESNTL300P models.

- Do not expose the battery charger to rain, snow or wet environments.
- The use of any attachment not recommended or sold by the battery charger manufacturer may result in risk of fire, electric shock, injury to persons or damage to property.
- Do not operate the charger if it has received a sharp blow, been dropped, or otherwise damaged in any way: return to supplier.
- Do not disassemble the charger: return to supplier when service or repair is required. Incorrect re-assembly may result in a risk of electric shock, fire or faulty operation.

WARNING – RISK OF EXPLOSIVE GASES

WORKING IN THE VICINITY OF A HIGH POWER BATTERY IS DANGEROUS. BATTERIES MAY GENERATE EXPLOSIVE GASES DURING NORMAL OPERATION AND CHARGING.

To reduce the risk of battery explosion, follow these instructions and those published by battery manufacturers and the manufacturer of any equipment you intend to use in the vicinity of the battery. Review cautionary marking on these products and any attached equipment.

PERSONAL PRECAUTIONS.

- (i) Someone should be within range of your voice or close enough to come to your aid when you work near a lead acid or high power battery.
- (ii) Have plenty of fresh water and soap nearby in case battery acid contacts skin, eyes or clothing.
- (iii) Wear complete eye protection and clothing protection. Avoid touching eyes whilst working near batteries.
- (iv) If battery acid or chemicals contact skin or clothing, wash immediately with soap and water. If acid or chemicals enter the eyes, immediately flood eyes with running cold water for at least 10 minutes and get immediate medical attention.
- (v) NEVER smoke or allow a spark or flame in vicinity of battery.
- (vi) Be extra cautious to reduce risk of dropping a metal tool on to the battery. It may spark or short-circuit the battery or other electrical part that may cause explosion.
- (vii) Remove personal metal items such as rings, bracelets, necklaces and watches when working with batteries. High power batteries can produce a short-circuit current high enough to weld a ring or the like to metal, causing severe burns.
- (viii) Use the charger only for charging battery types as stated on the charger. Do not use the charger for charging dry-cell batteries that are commonly used with home appliances. These batteries may burst and cause injury to persons and damage to property.
- (ix) NEVER CHARGE A FROZEN BATTERY

PRIOR TO INSTALLATION /COMMISSIONING

- Clean battery terminals. Be careful to keep corrosion from coming into contact with eyes.
- For lead acid batteries, add distilled water in each cell until the battery acid reaches a level specified by the battery manufacturer. This helps purge excessive gas from the cell. Do not overfill. For a battery without cell caps, carefully follow manufacturer's recharging instructions.
- Study all battery manufacturer's specific precautions, such as removing or not removing cell caps while charging and recommended rates of charge.
- Determine the battery voltage by referring to the engine manual and ensure this matches the charger's output voltage.

CHARGER LOCATION AND CONNECTION

- Never place the charger directly above the battery being charged: battery gases will corrode and damage the charger.
- When reading specific gravity or filling batteries, never allow battery acid or chemicals to drip on to the charger.
- Do not operate the charger in a closed-in area or restrict ventilation in any way.
- The battery charger should be connected to a grounded, metal, permanent wiring system; or an equipment–grounding conductor should be run with circuit conductors not connected to equipment-grounding terminal on the battery charger.
- Connections to the battery charger should comply with all local codes and ordinances.
- Open frame SNTL models – these chargers should be installed so that they are not likely to be contacted by people.
- Wiring for the AC supply input, DC charge output and DC control (e.g. alarm output) circuits must be physically separate, e.g. using separate wire harnesses and cable gland access. For AC supply and ground connections, use 1mm²/17 AWG or larger wire conductors rated to 90°C/194°F. For DC (charger to battery) leads, use 4mm²/11 AWG or larger wire.

For safe and correct use of the charger, follow steps below. Should you have any problems or the unit does not function as expected, consult our troubleshooting guide at the end of these instructions.

- Visually inspect unit for any signs of damage, caused by transport or storage.
- Mount the charger as outlined above, paying attention to ventilation and ambient temperature.
- Ensure the mains AC supply is isolated, and ensure the correct rated input voltage before connection.
- Ensure the charger is earthed at the marked earth terminal/stud.
- Check batteries in accordance with the manufacturer's guidelines.
- Check that the charger is correct for battery type, number of cells and voltage.
- Connect the charger to the batteries, observing correct polarity and ensuring a secure and tight connection.
- Switch on the charger at the mains AC power supply.

General Information

Please read the following before installing. A visual inspection of this product for damage during shipping is recommended before installation. It is your responsibility to ensure that qualified mechanical and electrical technicians install this product. If in doubt, please contact your local Computronic representative.



Sentinel 300P battery chargers provide new levels of DC power control, monitoring and protection for standby battery and engine starting applications.

Computronic advanced charger features included as standard:

Switch mode charging technology: high power efficiency and low heat dissipation, plus wide supply voltage tolerance, in a compact and lightweight package.

Multistage charging: float, bulk, absorption and AutoBoost stages ensure no compromise between rapid charge recovery and long term battery capacity and life.

Low output ripple: <1% ripple, beneficial for vented lead acid & NiCd cells, essential for VRLA, and configurable for use as a stand-alone DC power supply.

AutoBoost: triggered automatically on low charge levels, or manually by remote switch, AutoBoost temporarily increases the charge voltage before returning to float mode. AutoBoost equalises battery cell charge, maximising battery capacity and life, without overcharge and gassing.

Temperature compensation: ensures batteries are charged at the optimal voltage, which varies significantly with ambient temperature. Sentinel can measure temperature with a battery mounted sensor and adjust output voltage to prevent under or over charging.

In addition, the Sentinel 300P also provides:

Flexible configuration: microprocessor programmability for automatic or manual configuration of output voltages (12 or 24V nominal), cell types/numbers and charging applications – all in one standard model. Programming is by circuit board links and/or PC software configuration and monitoring tool.

Inputs & outputs: for remote charger control, and signalling of charge fail, high/low battery volts and mains fail faults. Standard model outputs comply with the NFPA 110 standard. Non-standard input/output functions available to special order.

Display, instrumentation and communication: options for LCD readout, analogue metering, plus RS485 / CANbus control and transmission of battery and charge data.

The Sentinel 300P is available either as an open-frame (UL-recognized) module for mounting in existing control panels, or as a wall-mounted (UL-listed) stainless steel enclosure with LCD and analogue metering options. Electrical connection is by circuit board mounted screw terminal blocks. On enclosed models, wiring harness access is by knock-out cable gland holes in the case side.

Specifications

Power supply

Operating voltage: 95 – 250 V AC
Operating frequency: 47 – 63 Hz.

DC Charge Output

Nominal voltage: programmable 12 or 24 V DC
Float/boost voltage: programmable, see 'DC output calibration' table
Maximum current limit: 10 A
Voltage ripple: <1%
Line regulation: <2%
Load regulation: <2%

Outputs x3 (optional x4 on non-CAN models):

All models:

1 x SPDT (RL1), 1 x SPNC (RL2), 1 x SPNO (RL3),
dry/volt-free contacts (common feed for RL1, RL2 & RL3)

Standard models (non-CAN configurations):

1 x SPNC (RL4), dry/volt-free contacts

standard model output functions are compliant with NFPA 110

Rating (all relays): 1A max @ 30 VDC (resistive load), UL class 2

Inputs x2

Closed to negative DC to activate

Physical

Operating temperature: –40 to +60°C / –40 to +140°F

Display viewability (LCD models only): 0 to 50°C / 32 to 122°F

Humidity: 20% to 90% RH

Dimensions: see Dimensions and Assembly section

Weights: see Dimensions and Assembly section

Electrical safety: 2006/95/EC

Electromagnetic compatibility:
2004/108/EC, EN 55022 class B
(EN 61000-6-1, EN 61000-6-3)

UL approvals

All (E)SNTL300P models:

BBGQ: UL1236, CSA 22.2 no. 107.2

BBHH: UL1236 SE

DC output calibration

Battery type:		float volts (V DC)	boost volts (V DC)
12V	Wet (vented) lead acid, 6 cells	13.5	14.1
	Calcium-Calcium, 6 cells	13.8	15.6
	Lead acid hybrid Sb-Ca, 6 cells	13.5	14.7
	VRLA, AGM, 6 cells	13.5	14.4
	VRLA, Gel, 6 cells	13.5	13.8
	NiCd, 10 cells	14.1	14.5
24V	Wet (vented) Lead acid, 12 cells	27.0	28.2
	Calcium-Calcium, 12 cells	27.6	31.2
	Lead acid hybrid Sb-Ca, 12 cells	27.0	29.4
	VRLA, AGM, 12 cells	27.0	28.8
	VRLA, Gel, 12 cells	27.0	27.6
	NiCd, 18 cells	25.6	26.1
	NiCd, 20 cells	28.2	29.0

Note: Calibration figures at 20 deg C. Output voltage will vary if temperature compensation is enabled – see Electrical Connection & Configuration section.

Dimensions and Assembly



CAUTION: Sentinel 300P chargers should be handled by the circuit board cover (SNTL models) or steel enclosure (ESNTL models). Care should be taken not to handle static sensitive components through exposed circuit boards and terminals.

SNTL300P models

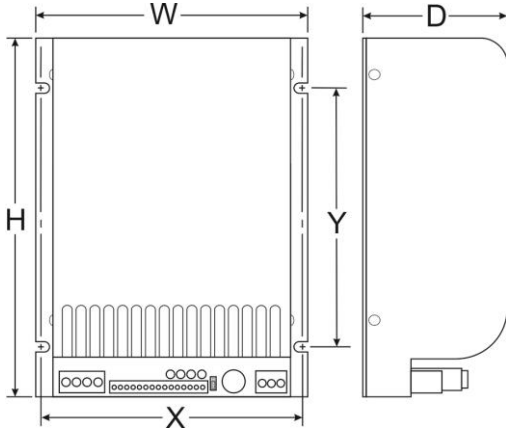

Overall:	
W	158 mm / 6.22 in.
H	208 mm / 8.19 in.
D	84 mm / 3.31 in.
Fixing holes:	
X	150 mm / 5.91 in.
Y	150 mm / 5.91 in.
Weight:	
	1.1 kg / 2.5 lb

- These chargers are designed for mounting in a vertical plane inside an enclosed control panel or housing. Mounting orientation should be as shown above, with electrical connection terminals lowermost.
- For safe heat dissipation, mount Sentinel in the orientation shown, with a minimum air-gap clearance of 40mm/1.5 in. above/below and 25mm/1 in. at the sides. Consideration must be given to ventilation for proper heat dissipation.
- For surface mounting, use the 2 centre slots (Ø 6mm/0.24in.) or 4 corner slots (Ø 6mm/0.24in.). Ensure that the mounting studs/bolts/nuts/screws adequately support the charger, and are tightened sufficiently to not to become loose during normal use, e.g. due to engine/equipment vibration.
- Optional clip for DIN rail mounting (2 required for each charger), part number 045-0001.

ESNTL300P models

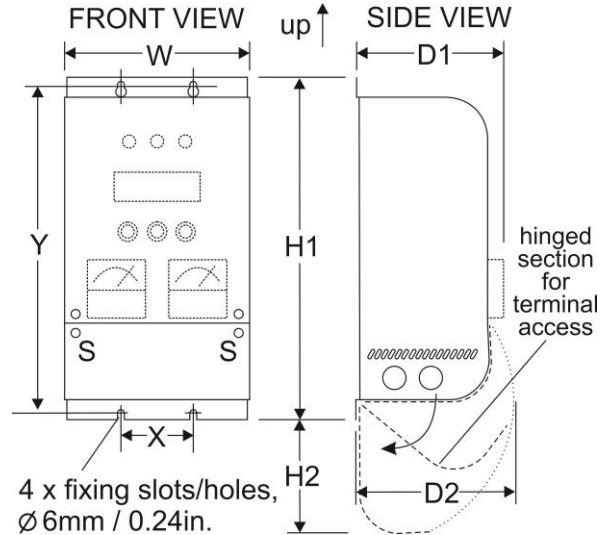

Overall:	
W	165mm / 6.50 in.
H1	300 mm / 11.81 in.
H2	80 mm / 3.15 in.
D1	125 mm / 4.92 in.
D2	130 mm / 5.12 in.
Fixing holes:	
X	63.5 mm / 2.50 in.
Y	285.5 mm / 11.25 in.
Weight:	
	2.0 – 2.1 kg / 4.4 – 4.6 lb

- These chargers are designed for wall or frame mounting in the orientation shown above, with enclosure air vents uppermost. For safe heat dissipation, allow a minimum air-gap clearance of 40mm/ 1.5 in. above/below and 25mm/1 in. at the sides. Consideration must be given to ventilation for proper heat dissipation.
- Mounting is via the enclosure back-plate, using 4 holes/slots (Ø 6mm/0.24in.) on the upper and lower edges. Ensure that the mounting studs/bolts/nuts/ screws adequately support the charger weight, and are tightened sufficiently to not to become loose during normal use, e.g. due to engine/equipment vibration.
- Access to the electrical connection terminals is via a hinged lower front plate. Remove the 2 x securing screws (marked S above), and then rotate the hinged section through 90 degrees.
- Electrical cable harness entry is via knock-out ports on either side of the enclosure, which must be carefully removed from the enclosure sides. A suitable cable-gland (20mm/0.8in. diam.) must be used to prevent damage to cables and stop unwanted entry into the inner part of charger. Wiring for DC charge output (connector CN1), DC control (CN2) and AC supply input (CN3) must be physically separate, e.g. using separate wire harnesses and case access ports: see page 5 section Wire Harness Separation.
- Connect the charger wiring as detailed in the following Electrical Connection section. When wiring is complete, and before using the charger, re-secure the hinged front section using the 2 fixing screws.

Electrical Connection



WARNING: DANGER OF INJURY OR DEATH. During normal operation, Sentinel is connected to high voltage AC circuits. Before connection, disconnection or handling of these chargers, ensure isolation of all AC power supplies. Connection or disconnection with live wiring can also cause hazardous sparking and component damage.

Connection - General

SNTL300P open-frame (protective cover) models:

Open frame models use 3 circuit board mounted screw terminal blocks:

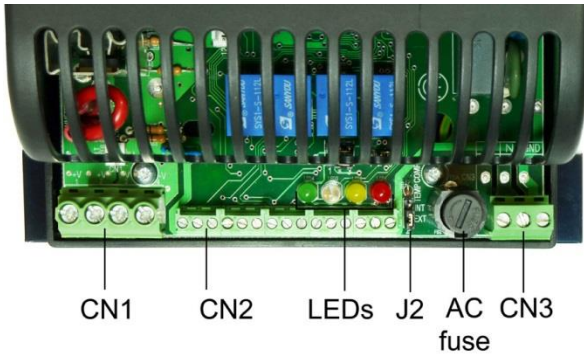

- **CN1:** a 4-way block for connection of the DC Charge Output. Use a 5 mm/0.2 in. flat-head screwdriver to tighten/loosen the terminals. For the DC Output (10 Amp max), use 4.0mm²/13 AWG or larger connecting wire. For details of fusing, see the Battery DC Charge Output section following.
- **CN2:** a 15-way block for connection of DC control signals: DC voltage sensing, temperature compensation remote sensor, control inputs and outputs. Use a 2.5mm/ 0.1 in. flat-head screwdriver to tighten/ loosen the terminals. Use 1mm²/17 AWG or larger wire for these connections. This connector block also includes terminals for RS485 and optional CAN (SAE J1939) communications: use wiring in accordance with the appropriate data communication standard (typically a twisted pair, with shield grounded at one end only).
- **CN3:** a 3-way block for connection of the mains AC live and neutral power supply. Use a 5mm/0.2in flat-head screwdriver to tighten/loosen the terminals. The AC supply ground/earth must be connected to a separate M4 stud marked FG (Frame Ground) on the charger chassis. For all AC supply/ground wiring, use 1mm²/ 17 AWG or larger wire conductors rated for 90°C/194°F. An AC fuse holder is located next to CN3: for fuse details, see the AC Input (power supply) section following.

4 LEDs (coloured green, blue, yellow, red) above the terminal blocks provide indication of configuration and operating status. Circuit board jumper J2 is for the configuration of automatic temperature compensation. For full details of LED and J2 operation, see Configuration and Operation section.

ESNTL300P (enclosed) models

Enclosed ESNTL models have the same circuit board terminal numbering as SNTL models.

Access to the screw terminals, and access for the wiring harness (via cable glands), is detailed in the Dimensions and Assembly section.

All models – wire harness separation

For all models, wire connections for the DC charge output (connector block CN1), DC control signals (CN2) and AC input supply (CN3) must be physically separated, e.g. using separate wiring harnesses to each connector block, separately routed through the case/panel. For enclosed ESNTL models, use separate cable gland access:

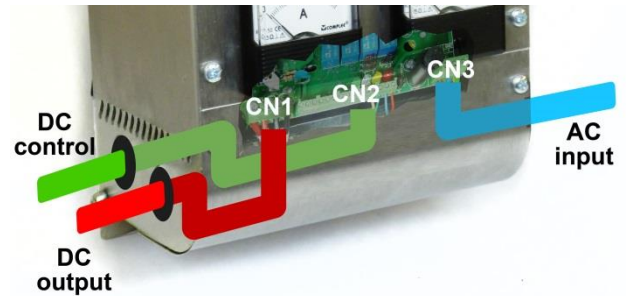

Battery DC Charge Output



Before DC connection or disconnection:

- Ensure AC supply input is isolated. **Disconnecting the batteries while the AC supply is live can result in sparking at the battery terminals, ignition of battery gasses and serious personal injury.**
- Check that the charger has been configured for compatibility with the battery type & voltage (see Configuration section below). **Incompatibility may result in damage to the charger, batteries and serious personal injury.**

Connect the Sentinel output to the battery terminals, observing the warnings above and the correct DC polarity:

CN1 pin	Function
1, 2	+ DC charge output
3, 4	- DC charge output

All (E)SNTL300P models include self-resetting electronic protection against reverse polarity, overload and short-circuit faults. In the event of such faults, the DC output switches off, protecting the charger. After a 4 second delay, Sentinel checks the DC output connection: if the fault has cleared, the output automatically re-activates; if the fault is still present, the output deactivates again, and the delay/check cycle repeats.

If the DC output fails to re-activate after a fault has cleared, contact your charger supplier for further advice.

Float & AutoBoost output voltages

The DC charge output can be configured to give one of several 12 or 24V 'charge profiles', each with Float and AutoBoost voltages that are optimised for the battery type and number of cells.

Charge profile configuration is either via circuit board DIP switches, or (on LCD models) using display menus and control keys: see Configuration section below. Charge profile can also be set using the Computronic SNTL300P-PCSUITE PC software tool and RS485 communication link. For full details, see separate software manual ref. ci0042.

Electrical Connection (cont.)

Typical Connection:

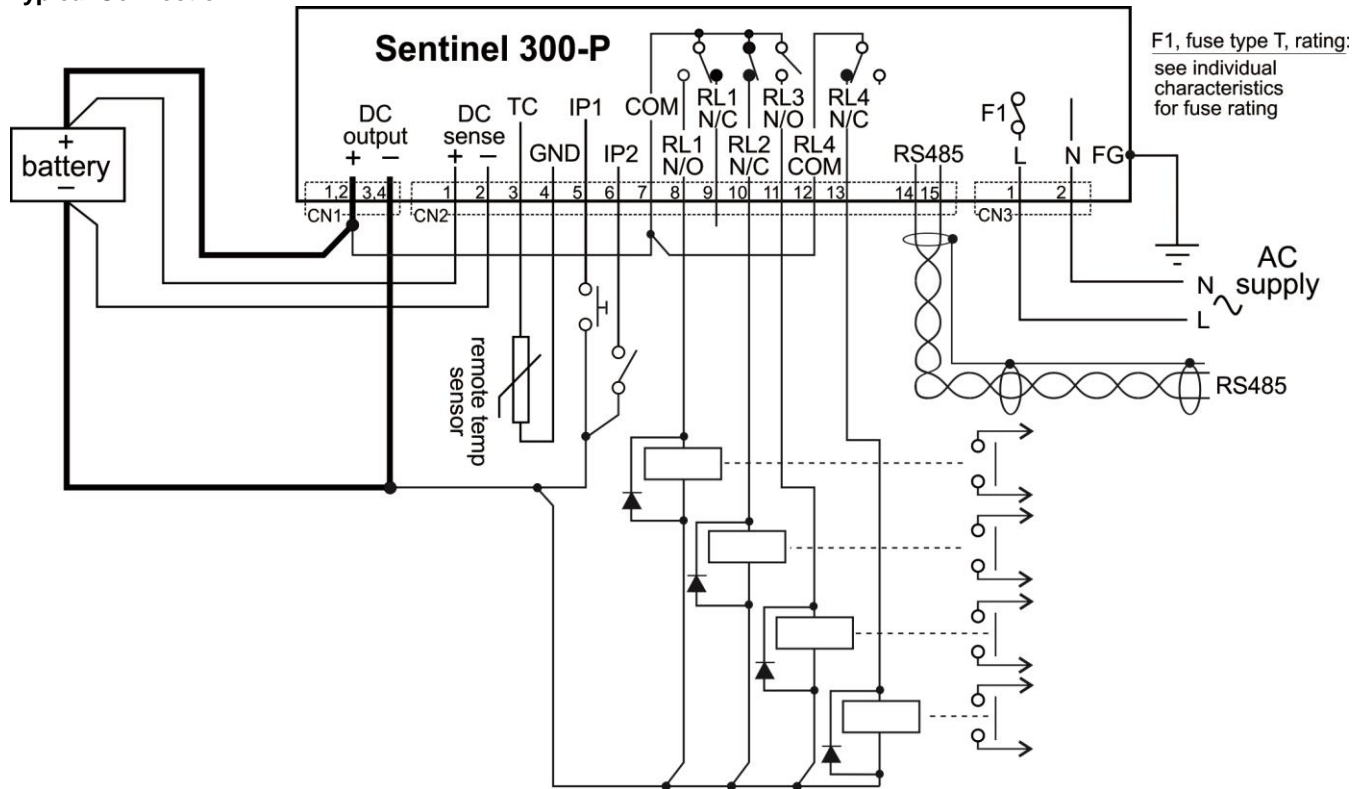

Notes:

1. AC input fusing (F1): replaceable, circuit board mounted fuse, rating as shown on the product label.
2. DC output fusing: all models include a self-resetting electronic output fuse.
3. DC output is isolated from chassis.
4. connection shown for standard configurations with output RL4. (RL4 is not available on units configured for CAN communication.)

Battery DC voltage sense

CN2 pin	Function
1	+ DC voltage sense
2	- DC voltage sense

These terminals are used to accurately measure battery voltage, independently of the voltage drop that can occur between the battery and DC charge output (particularly at higher charge currents, and with longer cables).



Accurate measurement of battery voltage allows Sentinel to automatically compensate for volt drops in the charging circuit, by increasing charge voltage.

Connect the battery DC Sense terminals to battery positive and negative using 1mm²/17 AWG or larger wire.

TC Temperature Compensation Sensor

CN2 pin	Function
3	TC (temperature compensation) sensor
4	Ground (for RTC sensor)

These terminals allow optional connection of a Computronic RTC temperature sensor. With the sensor connected, and the sensor head positioned to give the most accurate/representative measurement of battery temperature, Sentinel automatically varies DC output voltage for optimal charging. Circuit board jumper J2, located between terminal blocks CN2 and CN3, must also be in the correct position:

J2 jumper position / mode	Description
 External / disabled	(Factory default setting). Temperature compensation is enabled automatically when a remote RTC sensor is connected. For each 1°C change in ambient temperature above or below 20°C (within the range -10 to +50°C), output voltage automatically varies by 3mV per cell. Increasing ambient temperatures cause decreasing output voltages; decreasing ambient temperatures cause increasing output voltages. If no RTC sensor is connected, temperature compensation is automatically disabled and the output voltage does not vary with ambient temperature. Sensor connection and operating status is indicated by a blue LED – see Operation section for details.
 Internal	Not for customer use. Temperature measurement by internal sensor, for factory calibration only.

CN2 terminals 3 and 4 are designed for connection to a Computronic RTC sensor only. **DO NOT** connect other types of temperature sensor, such as thermocouples, thermistors or resistance probes.

The standard RTC sensor (part code 42.70.3619) includes a 3 metre lead assembly. Non-standard lead lengths are available to special order.

Electrical Connection (cont.)

Inputs (control)

All (E)SNTL300P models include two switch inputs for control purposes. On standard models:

CN2 pin	Function
5	Input 1: AutoBoost initiate. Allows the operator to manually initiate one AutoBoost cycle, regardless of battery voltage. Activation is by momentary connection to battery negative DC, e.g. using a push-to-make panel button.
6	Input 2: reduce output to nominal 12 or 24V. Connect input 1 to battery negative (e.g. via a switch or relay contact) for as long as the output needs to be reduced, e.g. for remotely controlled battery test equipment. In this mode, Sentinel continues to support any DC load up to the 10 Amp current limit.

Non-standard control input functions are available to special order.

Outputs (alarm)

All (E)SNTL300P models include at least three relay outputs, RL1 – 3. An additional output RL4 is available on standard (non-CAN) models/configurations. All output contacts are dry/volt-free (RL1, RL2 and RL3 have a common power feed), rated 1A @ 30VDC max.

The standard, NFPA 110 compliant output functions are shown below, but non-standard functions are available to special order:

CN2 pin	Function
7	Common power feed for RL1 – 3. Connect to the positive or negative DC supply as required.
8 9	RL1 normally open (N/O) contact. RL1 normally closed (N/C) contact Standard function: charge fail . Relay RL1: <ul style="list-style-type: none"> energises (pin 8 closes to pin 7, pin 9 opens from pin 7) during normal charging conditions. de-energises (pin 8 opens from pin 7, pin 9 closes to pin 7) if a charge fail fault occurs for longer than 2 minutes.
10	RL2 normally closed (N/C) contact. Standard function: low battery volts . Relay RL2: <ul style="list-style-type: none"> energises (pin 10 opens from pin 7) during normal charging conditions. de-energises (pin 10 closes to pin 7) if a low battery voltage fault occurs for longer than 2 minutes.
11	RL3 normally open (N/O) contact. Standard function: high battery volts . Relay RL3: <ul style="list-style-type: none"> de-energises (pin 11 opens from pin 7) during normal charging conditions energises (pin 11 closes to pin 7) if a high battery voltage fault occurs for longer than 2 minutes.

Models not configured for CAN J1939 communication include access to relay RL4:

CN2 pin	Function
12 13	RL4 common (COM) contact, volt-free/dry RL4 normally closed (NC) contact, volt free/dry Standard function: Mains fail . Relay RL4: <ul style="list-style-type: none"> energises (pin 13 opens from pin 12) when the mains AC supply is healthy. de-energises (pin 13 closes to pin 12) when the mains AC supply is off or failed.

CAN (Control Area Network) communications

SNTL300PC, ESNTL300PCL and ESNTL300PCLM models may be configured with a CAN 2.0B port for data exchange and control with other CAN devices. The CAN connection supports the SAE J1939 protocol commonly found in many industrial engine applications, or custom CAN protocols to OEM requirements. Connection:

CN2 pin	Function
12 13	CAN Hi CAN Lo

These terminals include an internal 120 Ohm terminating resistor, designed for connection at the end of the CAN network. Connection wiring must be in accordance with the CAN 2.0B standard, typically a twisted pair and shield cable of maximum network length 40 metres (132 feet), with the shield grounded at one end only.

RS485 communication

All 300P models include an RS485 MODBUS data port:

CN2 pin	Function
14 15	RS485 A RS485 B

These terminals include an internal 120 Ohm terminating resistor, for connection at the end of an RS485 network. Connection wiring must be in accordance with the RS485 standard, typically a twisted pair and shield cable with the shield grounded at one end only.

The RS485 port allows remote communication, configuration and monitoring with a PC running Computronic SNTL300P-PCSUITE software. The port can also be used to transmit RS485 Modbus data about battery and charger parameters, e.g. to a remote PLC, SCADA or other control/monitoring system. For further details, please see separate SNTL300P-PCSUITE document ci0042.

AC Input (power supply)



Before AC connection, disconnection or fuse replacement:

- Isolate the AC supply
- Ensure a good ground/earth connection to the ground/earth stud (marked FG) on the charger's metal chassis.
- Ensure the AC supply voltage is compatible with the charger's supply rating. **Exceeding the rated voltage may result in damage to the charger and connected equipment, and cause serious personal injury.**
- Fit only the fuse types/ratings shown on each product's label.



DANGER ! HIGH VOLTS

CN3 pin	Function
1 2	AC supply live, 95 to 250 VAC, 47 to 63 Hz AC supply neutral

Connect these terminals to the AC power supply. The AC supply ground/earth **must** be connected to the M4 stud marked FG (Frame Ground), located inside the charger case near connector CN3.

For AC input and ground connections, use 1mm²/ 17 AWG or larger wire conductors rated for temperature 90°C/194°F. All models include a replaceable anti-surge fuse (20mm, type T, 3.15A) in a circuit board mounted holder, located next to connector CN3.

Configuration and Operation

Operation

Power-up and POST sequence

At power up, Sentinel goes through a POST (Power On Self Test) sequence, including status indication using 4 LEDs (located on the main circuit board above connector CN2). The sequence is:

							POST LED display		
1) LED test: all lit for 2 sec, all off for 2 sec:									
2) Indication confirming standard 300P calibrations, 2 sec:							Flashing sequence: 		
3) Indication confirming selected charge profile, 2 sec:									
Nominal voltage	Battery type	Profile name	DIP switch settings (0 = off/down, 1 = on/up)						
Auto / local	12 or 24 wet (vented) lead acid	AUTO DETECT (Local)	0	0	0	0	0	0	Flashing:
Auto / remote		AUTO DETECT (Remote)	0	0	0	0	1	0	Flashing sequence:
12V	Wet (vented) lead acid, 6 cells	12V WET LA	0	0	0	1	0	0	
	Calcium Calcium, 6 cells	12V CA/CA	0	0	1	0	0	0	
	Lead acid hybrid Sb-Ca, 6 cells	12V LA HYBRID	0	0	1	1	0	0	
	VRLA, AGM, 6 cells	12V VRLA - AGM	0	1	0	0	0	0	
	VRLA, Gel, 6 cells	12V VRLA - GEL	0	1	0	1	0	0	
	NiCd, 10 cells	10 CELL NiCd	0	1	1	0	0	0	
	12V power supply	12V POWER SUPPLY	0	1	1	1	0	0	
24V	NiCd, 18 cells	18 CELL NiCd	1	0	0	0	0	0	
	NiCd, 20 cells	20 CELL NiCd	1	0	0	1	0	0	
	Wet (vented) lead acid, 12 cells	24V WET LA	1	0	1	0	0	0	
	Calcium Calcium, 12 cells	24V CA/CA	1	0	1	1	0	0	
	Lead acid hybrid Sb-Ca, 12 cells	24V LA HYBRID	1	1	0	0	0	0	
	VRLA, AGM, 12 cells	24V VRLA - AGM	1	1	0	1	0	0	
	VRLA, Gel, 12 cells	24V VRLA - GEL	1	1	1	0	0	0	
	24V power supply	24V POWER SUPPLY	1	1	1	1	0	0	

After the POST sequence, the LEDs revert to indication of operating status. See LED Indication section below.

Auto mode battery detection

Immediately after power-up, if an 'Auto' charge profile has been selected, the Sentinel 300P measures the connected battery voltage and operates as follows:

Measured voltage	Operation
< 1 V	No output: battery missing fault signalled.
1 to 16.0 V	Charge output: 12V vented lead acid.
16.1 to 32 V	Charge output: 24V vented lead acid.

Float mode

If measured battery voltage is within normal limits (above 12.5 V for 12V nominal batteries, and above 25.0 V for 24V nominal batteries), Sentinel adopts float mode charging, indicated by a constantly lit yellow LED. Sentinel maintains the battery at the float voltage (appropriate for the selected battery type), and supplies any additional DC load current (up to the maximum rated 10 Amps).

Battery check

When in float charge mode, Sentinel periodically checks for a 'battery missing' fault. During this check, output current reduces to nominal (12 or 24V) for approx. 30 seconds and the yellow LED goes off.

The default period for checking 'battery missing' is every 30 minutes, but this time can be adjusted using the SNTL300P-PCSUITE configuration tool. Once Sentinel

registers a battery missing fault, it checks for reconnection once every minute (non-adjustable).

Sentinel does not check for 'battery missing' during AutoBoost operation, to ensure maximum charge rate is maintained.

AutoBoost

If measured battery voltage falls below the Boost Initiate threshold (below 12.5 V for 12V nominal batteries, or below 25.0 V for 24V nominal batteries), Sentinel adopts AutoBoost mode (indicated by a slow-flashing yellow LED) and charge output increases to the higher Boost voltage level.

Once measured battery voltage has increased to the Boost level, Sentinel enters a Boost Extension period (360 mins on standard units), during which time Boost voltage is maintained and the yellow LED flashes rapidly.

At the end of the Boost extension period, output voltage and current reduces, but the yellow LED continues to flash rapidly. In this Boost Decay phase, battery voltage naturally decreases back towards float level. Sentinel then reverts to float mode charging, indicated by a continually lit yellow LED.

AutoBoost can also be initiated manually by an operator, regardless of battery voltage. This is achieved on standard units through input 2: after input activation, e.g. by a momentary push-to-make panel switch, Sentinel goes through a single AutoBoost cycle.

Configuration and Operation (cont.)

DIP switch configuration



WARNING: AC and DC connections must be isolated during DIP switch configuration. The correct battery type and cell number must be configured correctly before charger power-up and battery connection. Incorrect configuration may result in under or over charge of batteries, which may cause failure or damage to the batteries, charger and connected equipment, and result in serious personal injury.

All Sentinel models include a 6 way DIP switch for configuration of battery type and cell number. The DIP switch is accessible through a cut-out in the case rear:

Open frame SNTL models



Enclosed ESNTL models



DIP switch functions:





1 – 4	Sets the charge profile (battery type and cell number) when 'local' mode is selected – see switch 6 below.
5	Sets whether the Sentinel charge profile is set in local or remote mode: Local mode: charge profile set by DIP switches 1 to 4. The default setting is 'Local, Auto', where Sentinel automatically selects 12 or 24V operation based on the battery voltage measured at power up – see 'operation' below. Remote mode: charge profile set by remote RS485 communication (e.g. SNTL300P-PCSUITE software), or (on LCD models only) using display menu options. When remote mode is selected, the default charge profile is 'Auto'.
6	Reserved use. Do not adjust from default (0/off/down) setting.

Nominal voltage	Battery type	Profile name	DIP switch setting (0 = off/down, 1 = on/up)						voltage/time settings					
			1	2	3	4	5	6	float (VDC)	boost (VDC)	boost initiate (VDC)	boost time (min)	low alarm (VDC)	high alarm (VDC)
DIP switches 1 – 4, local mode settings														
12/24V	Auto (12V or 24V wet lead acid)	AUTO DETECT	0	0	0	0	0	0	13.5/ 27.0	14.1/ 28.2	12.5/ 25.0	360	12.0/ 24.0	16.0/ 32.0
12V	Wet (vented) lead acid, 6 cells	12V WET LA	0	0	0	1	0	0	13.5	14.1	12.5	360	12.0	16.0
	Calcium Calcium, 6 cells	12V CA/CA	0	0	1	0	0	0	13.8	15.6	12.5	360	12.0	16.0
	Lead acid hybrid Sb-Ca, 6 cells	12V LA HYBRID	0	0	1	1	0	0	13.5	14.7	12.5	360	12.0	16.0
	VRLA, AGM, 6 cells	12V VRLA - AGM	0	1	0	0	0	0	13.5	14.4	12.5	360	12.0	16.0
	VRLA, Gel, 6 cells	12V VRLA - GEL	0	1	0	1	0	0	13.5	13.8	12.5	360	12.0	16.0
	NiCd, 10 cells	10 CELL NiCd	0	1	1	0	0	0	14.1	14.5	12.5	360	12.0	16.0
	12V power supply	12V POWER SUPPLY	0	1	1	1	0	0	12.0	n/a	n/a	n/a	n/a	n/a
24V	NiCd, 18 cells	18 CELL NiCd	1	0	0	0	0	0	25.6	26.1	25.0	360	24.0	32.0
	NiCd, 20 cells	20 CELL NiCd	1	0	0	1	0	0	28.2	29.0	25.0	360	24.0	32.0
	Wet (vented) lead acid, 12 cells	24V WET LA	1	0	1	0	0	0	27.0	28.2	25.0	360	24.0	32.0
	Calcium Calcium, 12 cells	24V CA/CA	1	0	1	1	0	0	27.6	31.2	25.0	360	24.0	32.0
	Lead acid hybrid Sb-Ca, 12 cells	24V LA HYBRID	1	1	0	0	0	0	27.0	29.4	25.0	360	24.0	32.0
	VRLA, AGM, 12 cells	24V VRLA - AGM	1	1	0	1	0	0	27.0	28.8	25.0	360	24.0	32.0
	VRLA, Gel, 12 cells	24V VRLA - GEL	1	1	1	0	0	0	27.0	27.6	25.0	360	24.0	32.0
	24V power supply	24V POWER SUPPLY	1	1	1	1	0	0	24.0	n/a	n/a	n/a	n/a	n/a
DIP switch 5: local / remote mode:														
Local			x	x	x	x	0	0	Local mode, profile set by switches 1-4					
Remote		Auto Remote	x	x	x	x	1	0	Remote mode, profile set by LCD or PC software. Default charge profile: 'Auto'.					
DIP switch 6: reserved														
			x	x	x	x	x	0	Default setting, do not adjust.					

Configuration and Operation (cont.)

LED indication

In normal operation, the four circuit board LEDs indicate operating status: fault conditions, charge mode, temperature compensation and AC supply:

LED operation	Status	
 Red	on	Fault condition (except AC supply & battery connection errors).
	flashing, slow	AC supply not available (DC connected).
	flashing, fast	Battery connection error.
	off	No fault conditions.
 Yellow	on	In Float mode.
	flashing, slow	In AutoBoost mode.
	flashing, fast	In AutoBoost extension mode / boost decay.
	off	Output off / output to nominal.
 Blue	on	Temperature compensation active, sensor connected.
	flashing, slow	Temperature compensation auto disabled due to external fault.
	flashing, fast	Temperature compensation at absolute limit, i.e. <-10°C or >+50°C.
	off	Temperature compensation disabled.
 Green	on	AC supply available, charge output on.
	flashing, slow	AC supply available, charge output off.
	flashing, fast	Boost decay or battery missing (if red LED is also on).
	off	AC supply not available.

LCD Models

Enclosed models ESNTL300PCL and ESNTL300PCLM include a backlit graphic LCD, three push-button controls (Up, Down, Enter), and three additional indicating LEDs:

- Green: CAN network status (CAN-enabled models only). Lights continuously in normal CAN operation.
- Yellow: charging mode, operation as yellow circuit board LED.
- Red: fault conditions, operation as red circuit board LED.

In normal charging mode, the LCD displays Sentinel and battery status, e.g. operating mode, charge voltages and currents, date/time, faults, etc.

In configuration menu modes, the LCD and push-buttons can be used by the operator to view/edit operating parameters and options (date/time, charge profiles, etc).

Normal charging: float and AutoBoost modes

At power-up, Sentinel displays an initial message that includes the unit firmware version, followed by...

```
*****
* SENTINEL 300P *
* V 3.0 *
*****
```

The default operating screen, showing date, time, battery volts, charge current and charge mode.

```
20/05/10 10:23
VDC: 13.2 ADC: 8.5

FLOAT CHARGE
```

When Sentinel is in AutoBoost mode, the 4th line changes to show the current boost stage, displaying (in sequence) 'ramping to boost', 'boost extension' and 'boost decay'.

Fault messages

When a fault condition occurs, an appropriate message is shown on the display 3rd line.

```
20/05/10 10:23
VDC: 13.2 ADC: 8.5
CHARGE FAIL
FLOAT CHARGE
```

Fault messages automatically clear from the display when the fault condition clears. In the event of multiple faults, the 3rd line displays the highest priority message, ranked in the following order (highest priority first):

- AC mains failure
- DC connection error
- Sensed connection error
- Battery missing (detected during battery check routine)
- Incorrect battery type (when configured with a 12V charge profile, but the connected battery voltage is above 16.1 V).
- No battery detected (when configured with an 'auto' charge profile, but the connected battery, or lack of connection, is below 1.0V).
- High battery voltage
- Charge fail
- Low battery voltage
- Volt sense level fault

Configuration mode

The LCD and control keys can be used to view or change configuration settings. The Sentinel 300P has three configuration menus, named 'Settings', 'System' and 'CAN'. While the operator is viewing or editing these menu settings, Sentinel continues normal charge operation, but current charging status or fault information is not displayed on the LCD.

Settings menu

This sequence of screens allows viewing (but not editing) of several operating and device parameters.

To access the Settings menu, press and hold the Up and Down keys. The first screen displayed is:

```
SETTINGS
FLOAT: XX.XVDC
BOOST: XX.XVDC
BOOST EXT: XXX MINS
```

Press Up or Down keys to view more settings:

```
SETTINGS
LOW ALARM: XX.XVDC
HIGH ALARM: XX.XVDC
ALARM DELAY: XXX SEC
```

Press Up or Down keys to view more settings:

```
SETTINGS
MODEL: XXXXXXXXX
SERIAL NO: XXXXXX FIRMWARE:
XXXXXX
```

Press Up and Down to review the parameters again, or press Enter to exit the Settings menu.

Configuration and Operation (cont.)

System Menu

This passkey-protected menu allows the clearing of the system log, the resetting of date/time and AC/charging hours run, and (if DIP switch 6 is set to 'remote') the selection of a charge profile.

To access the System menu, press and hold the Up and Enter keys.

4 digit passkey entry.

Use the Up or Down keys to change the first digit, press enter, then repeat for 2nd, 3rd and 4th digits.

```
DD:MM:YY HH:MM
SYSTEM MENU
ENTER PASSKEY? X
UP & DOWN:CHANGE ENTER:OK
```

Correct passkey entry (the factory default is 1234) allows viewing and editing of the following functions:

Date and time

Press Enter to edit date and time (5 separate screens for setting day, month, year, hours, minutes), or press Down to skip (bypass) this section and move on to...

```
DD:MM:YY HH:MM
SYSTEM MENU
EDIT DATE & TIME?
ENTER - YES DOWN - SKIP
```

Reset AC on hours

Sentinel stores data on the number of hours it has been powered. Press Enter to reset this to zero, or press Down to keep the existing value and move on to...

```
DD:MM:YY HH:MM
SYSTEM MENU
RESET AC ON HOURS?
ENTER - YES DOWN - SKIP
```

Reset Charging hours

Sentinel stores data on the number of hours it has been charging the battery. Press Enter to reset this to zero, or press Down to keep the existing value and move on to...

```
DD:MM:YY HH:MM
SYSTEM MENU
RESET CHARGING HOURS?
ENTER - YES DOWN - SKIP
```

Change Passkey

Allows custom setting of the 4 digit System Menu passkey. Press Enter to change (a series of four screens, one for each passkey digit), or press Down to skip this and move on to...

```
DD:MM:YY HH:MM
SYSTEM MENU
CHANGE PASSKEY?
ENTER - YES DOWN - SKIP
```

Select Charging Profile

Allows the charge profile to be changed (but only if DIP switch 6 is set to 1/on/up: an error message results if switch 6 is set to 0/off/down.)

```
DD:MM:YY HH:MM
SYSTEM MENU
SELECT CHARGE PROFILE?
ENTER - YES DOWN - SKIP
```

Press Enter to change the charge profile, which is selected on a following screen; or press Down to skip this and move on to...

Confirm changes

Press Enter to confirm any System Menu changes and exit. Press Down to discard the changes and exit.

```
DD:MM:YY HH:MM
SYSTEM MENU
CONFIRM CHANGES?
ENTER - YES DOWN - CANCEL
```

CAN Menu

On CAN-enabled units, this menu is reserved for viewing/editing of the CAN network settings.

To access this menu, press and hold Down and Enter keys. The settings in this menu settings will vary according to part number specification: please contact Computronic for separate details or documentation.

Maintenance, Fault Finding and Warranty

Maintenance and Warranty

Sentinel chargers are supplied with a 2 year warranty on parts and workmanship.

Maintenance is limited to keeping the charger free from ingress of dust, dirt or moisture, and ensuring clear air-flow for ventilation.

In the event of an operating query or suspected fault, please consult the sections in this manual on LED/LCD indication, and the flowchart on page 12, or contact your supplier for further advice before returning the charger.



WARNING: Except for AC fuse replacement, Sentinel 300P battery chargers are not user-serviceable.

In the event of a failure, the charger should be returned to the supplier. No attempt should be made to repair the charger. Any attempt to do so may invalidate warranties, cause damage to the charger and connected equipment, and result in serious personal injury.

Maintenance, Fault Finding and Warranty (cont.)

Troubleshooting Flowchart:

