

NPN Silicon Digital Transistor

BCR 148

- Switching circuit, inverter, interface circuit, driver circuit
- Built-in bias resistor ($R_1 = 47 \text{ k}\Omega$, $R_2 = 47 \text{ k}\Omega$)

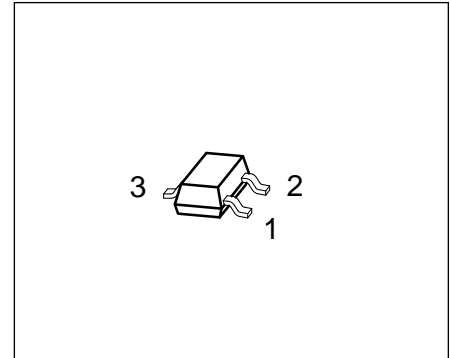

Type	Marking	Ordering Code (8-mm tape)	Pin Configuration			Package
			1	2	3	
BCR 148	WEs	Q62702-C2261	B	E	C	SOT-23

Maximum Ratings

Parameter	Symbol	Values	Unit
Collector-emitter voltage	V_{CEO}	50	V
Collector-base voltage	V_{CBO}	50	
Emitter-base voltage	V_{EBO}	10	
Input on voltage	$V_{i(on)}$	50	
Collector current	I_C	70	mA
Total power dissipation, $T_S \leq 79 \text{ }^\circ\text{C}$	P_{tot}	330	mW
Junction temperature	T_j	150	$^\circ\text{C}$
Storage temperature range	T_{stg}	- 65 ... + 150	

Thermal Resistance

Junction - ambient ¹⁾	R_{thJA}	≤ 350	K/W
Junction - soldering point	R_{thJS}	≤ 240	

¹⁾ Package mounted on epoxy pcb 40 mm x 40 mm x 1.5 mm
Mounting pad for the collector lead min 1 cm² Cu.

Electrical Characteristics

at $T_A = 25\text{ °C}$, unless otherwise specified.

Parameter	Symbol	Values			Unit
		min.	typ.	max.	

DC Characteristics

Collector-emitter breakdown voltage $I_C = 100\text{ }\mu\text{A}$, $I_B = 0$	$V_{(BR)CEO}$	50	–	–	V
Collector-base breakdown voltage $I_C = 10\text{ }\mu\text{A}$, $I_E = 0$	$V_{(BR)CBO}$	50	–	–	
Emitter-base breakdown voltage $I_C = 10\text{ }\mu\text{A}$, $I_C = 0$	$V_{(BR)EBO}$	10	–	–	
Collector-base cutoff current $V_{CB} = 40\text{ V}$, $I_E = 0$	I_{CBO}	–	–	100	nA
DC current gain $I_C = 5\text{ mA}$, $V_{CE} = 5\text{ V}$	h_{FE}	70	–	–	–
Collector-emitter saturation voltage $I_C = 10\text{ mA}$, $I_B = 0.5\text{ mA}$	V_{CEsat}	–	–	0.3	V
Input off voltage $I_C = 100\text{ }\mu\text{A}$, $V_{CE} = 5\text{ V}$	$V_{i(off)}$	0.8	–	1.5	
Input on voltage $I_C = 2\text{ mA}$, $V_{CE} = 0.3\text{ V}$	$V_{i(on)}$	1.0	–	3.0	
Input resistor	R_1	32	47	62	k Ω
Resistor ratio	R_1/R_2	0.9	1	1.1	–

AC Characteristics

Transition frequency $I_C = 10\text{ mA}$, $V_{CE} = 5\text{ V}$, $f = 100\text{ MHz}$	f_T	–	100	–	MHz
Collector-base capacitance $V_{CB} = 10\text{ V}$, $I_E = i_E = 0$, $f = 1\text{ MHz}$	C_{cb}	–	3	–	pF

Total power dissipation $P_{\text{tot}} = f(T_A^*; T_S)$

* Package mounted on epoxy

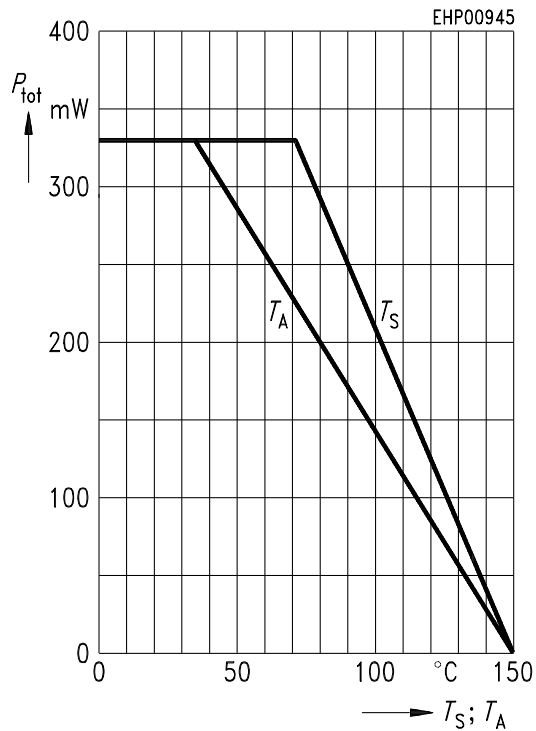

Package Outline

SOT-23

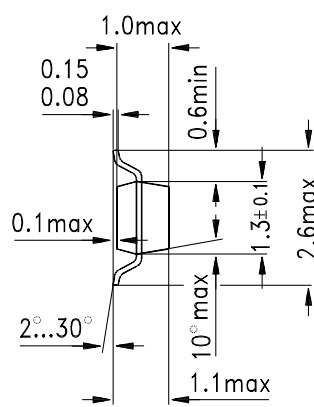
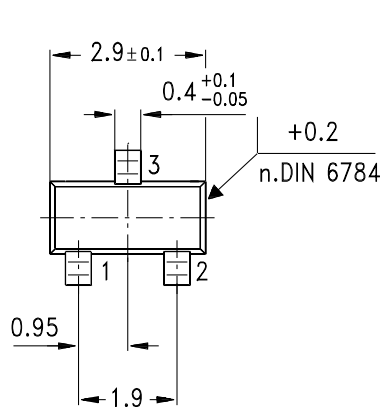

GPS05557

Dimensions in mm

Pin Configuration

