



STP45NF06 STB45NF06

N-CHANNEL 60V - 0.022Ω - 38A TO-220/D²PAK
STripFET™II MOSFET

Table 1: General Features

TYPE	V _{DSS}	R _{DS(on)}	I _D
STP45NF06	60 V	< 0.028 Ω	38 A
STB45NF06	60 V	< 0.028 Ω	38 A

- TYPICAL R_{DS(on)} = 0.022Ω
- EXCEPTIONAL dv/dt CAPABILITY
- STANDARD THRESHOLD DRIVE
- 100% AVALANCHE TESTED

DESCRIPTION

This MOSFET is the latest development of STMicroelectronics unique "Single Feature Size™" strip-based process. The resulting transistor shows extremely high packing density for low on-resistance, rugged avalanche characteristics and less critical alignment steps therefore a remarkable manufacturing reproducibility.

APPLICATIONS

- HIGH-EFFICIENCY DC-DC CONVERTERS
- SOLENOID AND RELAY DRIVERS
- DC-DC & DC-AC CONVERTERS

Table 2: Order Codes

SALES TYPE	MARKING	PACKAGE	PACKAGING
STP45NF06	P45NF06	TO-220	TUBE
STB45NF06T4	B45NF06	D ² PAK	TAPE & REEL

Figure 1: Package

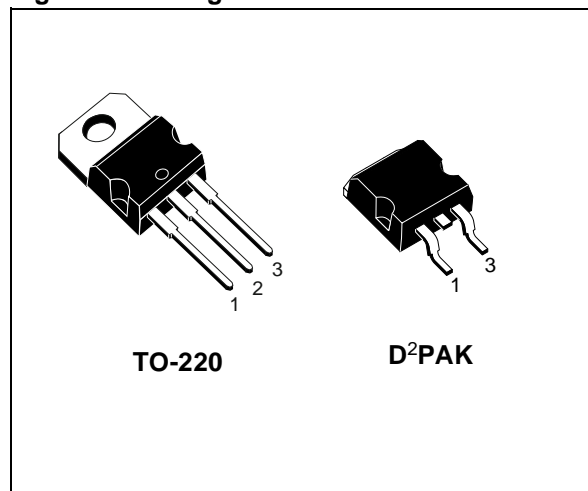

Figure 2: Internal Schematic Diagram

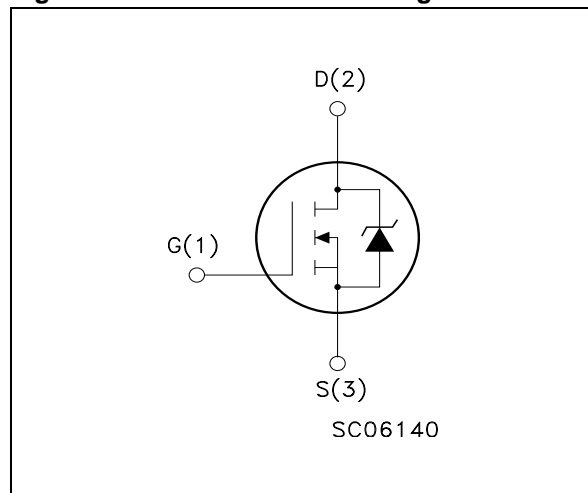

Table 3: Absolute Maximum ratings

Symbol	Parameter	Value	Unit
V_{DS}	Drain-source Voltage ($V_{GS} = 0$)	60	V
V_{DGR}	Drain-gate Voltage ($R_{GS} = 20\text{ k}\Omega$)	60	V
V_{GS}	Gate- source Voltage	± 20	V
I_D	Drain Current (continuous) at $T_C = 25^\circ\text{C}$	38	A
I_D	Drain Current (continuous) at $T_C = 100^\circ\text{C}$	26	A
$I_{DM}(\bullet)$	Drain Current (pulsed)	152	A
P_{TOT}	Total Dissipation at $T_C = 25^\circ\text{C}$	80	W
	Derating Factor	0.53	W/ $^\circ\text{C}$
dv/dt (1)	Peak Diode Recovery voltage slope	7	V/ns
T_{stg}	Storage Temperature	-65 to 175	$^\circ\text{C}$
T_j	Max. Operating Junction Temperature	175	$^\circ\text{C}$

(\bullet) Pulse width limited by safe operating area

(1) $I_{SD} \leq 38\text{A}$, $di/dt \leq 300\text{A}/\mu\text{s}$, $V_{DD} \leq V_{(BR)DSS}$, $T_j \leq T_{JMAX}$.

Table 4: Thermal Data

Rthj-case	Thermal Resistance Junction-case Max	1.87	$^\circ\text{C}/\text{W}$
Rthj-amb	Thermal Resistance Junction-ambient Max	62.5	$^\circ\text{C}/\text{W}$
T_l	Maximum Lead Temperature For Soldering Purpose	300	$^\circ\text{C}$

Table 5: Avalanche Characteristics

Symbol	Parameter	Max Value	Unit
I_{AR}	Avalanche Current, Repetitive or Not-Repetitive (pulse width limited by T_j max)	38	A
E_{AS}	Single Pulse Avalanche Energy (starting $T_j = 25^\circ\text{C}$, $I_D = I_{AR}$, $V_{DD} = 50\text{V}$)	135	mJ

ELECTRICAL CHARACTERISTICS ($T_{CASE} = 25^\circ\text{C}$ UNLESS OTHERWISE SPECIFIED)

Table 6: Off

Symbol	Parameter	Test Conditions	Min.	Typ.	Max.	Unit
$V_{(BR)DSS}$	Drain-source Breakdown Voltage	$I_D = 250\ \mu\text{A}$, $V_{GS} = 0$	60			V
I_{DSS}	Zero Gate Voltage Drain Current ($V_{GS} = 0$)	$V_{DS} = \text{Max Rating}$ $V_{DS} = \text{Max Rating}$, $T_C = 125^\circ\text{C}$			1 10	μA μA
I_{GSS}	Gate-body Leakage Current ($V_{DS} = 0$)	$V_{GS} = \pm 20\text{V}$			± 100	nA

Table 7: On

Symbol	Parameter	Test Conditions	Min.	Typ.	Max.	Unit
$V_{GS(th)}$	Gate Threshold Voltage	$V_{DS} = V_{GS}$, $I_D = 250\ \mu\text{A}$	2	3	4	V
$R_{DS(on)}$	Static Drain-source On Resistance	$V_{GS} = 10\text{V}$, $I_D = 19\text{A}$		0.022	0.028	Ω

ELECTRICAL CHARACTERISTICS (CONTINUED)

Table 8: Dynamic

Symbol	Parameter	Test Conditions	Min.	Typ.	Max.	Unit
g_{fs} (1)	Forward Transconductance	$V_{DS} > I_{D(on)} \times R_{DS(on)max}$, $I_D = 19\text{ A}$		24		S
C_{iss} C_{oss} C_{rss}	Input Capacitance Output Capacitance Reverse Transfer Capacitance	$V_{DS} = 25\text{V}$, $f = 1\text{ MHz}$, $V_{GS} = 0$		1730 215 63		pF pF pF

Table 9: Switching On

Symbol	Parameter	Test Conditions	Min.	Typ.	Max.	Unit
$t_{d(on)}$	Turn-on Delay Time	$V_{DD} = 30\text{V}$, $I_D = 19\text{A}$		20		ns
t_r	Rise Time	$R_G = 4.7\Omega$, $V_{GS} = 10\text{V}$ (see test circuit, Figure 3)		100		ns
Q_g Q_{gs} Q_{gd}	Total Gate Charge Gate-Source Charge Gate-Drain Charge	$V_{DD} = 48\text{V}$, $I_D = 38\text{A}$, $V_{GS} = 10\text{V}$		43 9 15	58	nC nC nC

Table 10: Switching Off

Symbol	Parameter	Test Conditions	Min.	Typ.	Max.	Unit
$t_{d(off)}$	Turn-off-Delay Time	$V_{DD} = 30\text{V}$, $I_D = 19\text{A}$,		50		ns
t_f	Fall Time	$R_G = 4.7\Omega$, $V_{GS} = 10\text{V}$ (see test circuit, Figure 3)		20		ns
$t_{d(off)}$	Off-voltage Rise Time	$V_{clamp} = 48\text{V}$, $I_D = 38\text{A}$		45		ns
t_f	Fall Time	$R_G = 4.7\Omega$, $V_{GS} = 10\text{V}$		42		ns
t_c	Cross-over Time	(see test circuit, Figure 5)		60		ns

Table 11: Source Drain Diode

Symbol	Parameter	Test Conditions	Min.	Typ.	Max.	Unit
I_{SD}	Source-drain Current				38	A
I_{SDM} (1)	Source-drain Current (pulsed)				152	A
V_{SD} (2)	Forward On Voltage	$I_{SD} = 38\text{A}$, $V_{GS} = 0$			1.5	V
t_{rr}	Reverse Recovery Time	$I_{SD} = 38\text{A}$, $di/dt = 100\text{A}/\mu\text{s}$,		95		ns
Q_{rr}	Reverse Recovery Charge	$V_{DD} = 100\text{V}$, $T_j = 150^\circ\text{C}$		260		nC
I_{RRM}	Reverse Recovery Current	(see test circuit, Figure 5)		5.5		A

(1) Pulsed: Pulse duration = 300 μs , duty cycle 1.5 %.

(2) Pulse width limited by safe operating area.

Figure 3: Safe Operating Area

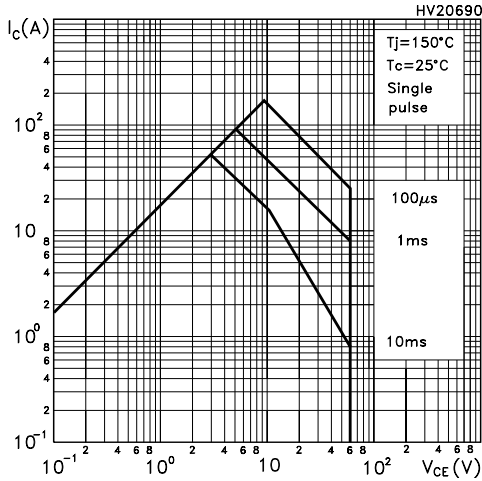

Figure 4: Output Characteristics

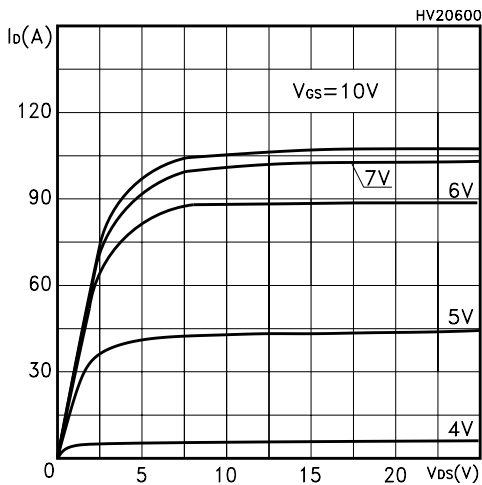

Figure 5: Transconductance

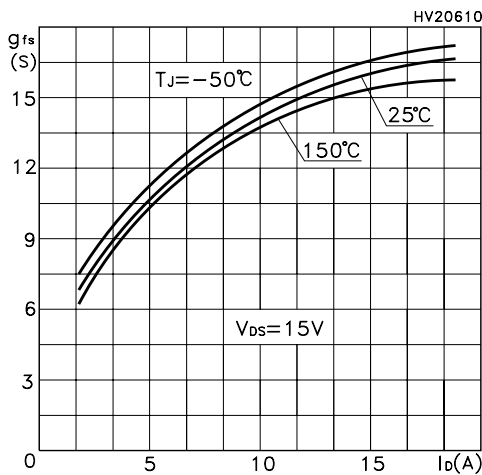

Figure 6: Thermal Impedance

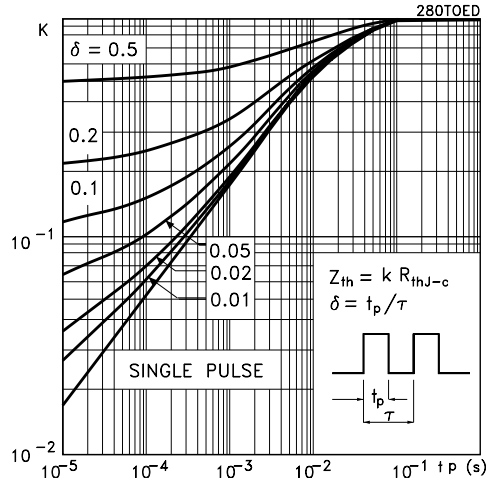

Figure 7: Transfer Characteristics

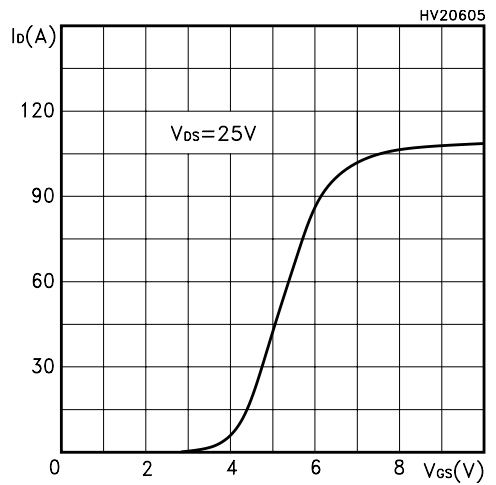

Figure 8: Static Drain-source On Resistance

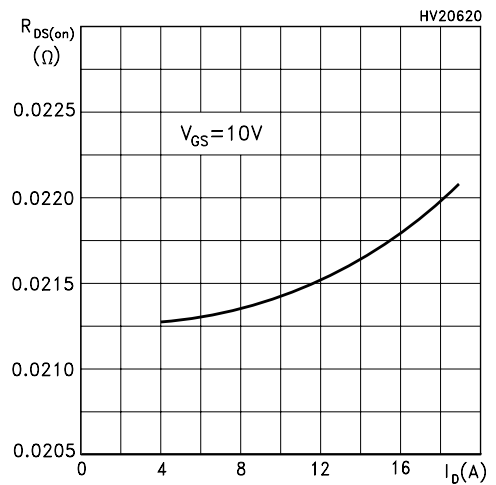

Figure 9: Gate Charge vs Gate-source Voltage

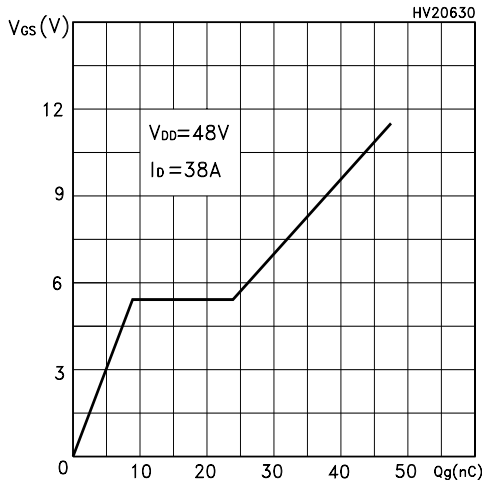

Figure 10: Normalized Gate Threshold Voltage vs Temperature

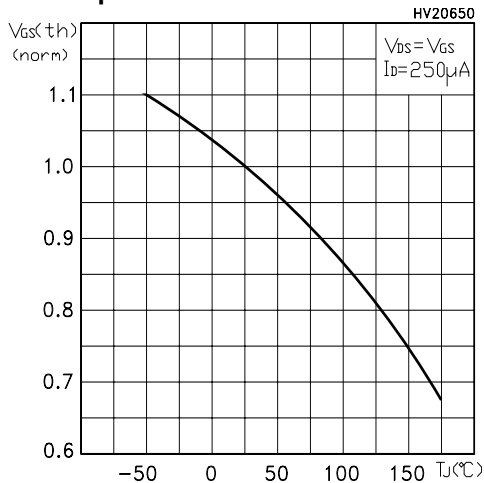

Figure 11: Dource-Drain Diode Forward Characteristics

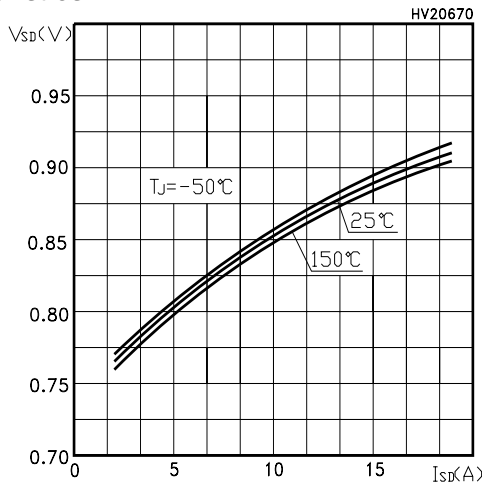

Figure 12: Capacitance Variations

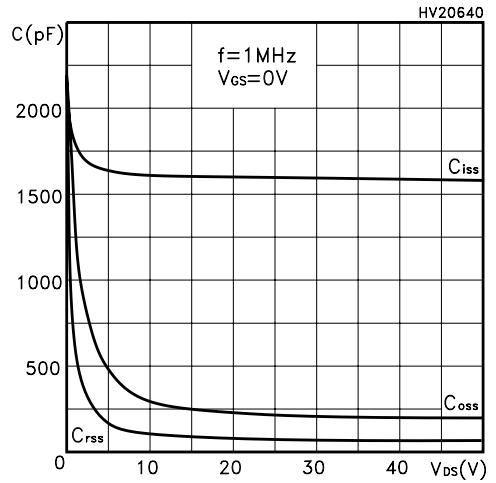

Figure 13: Normalized On Resistance vs Temperature

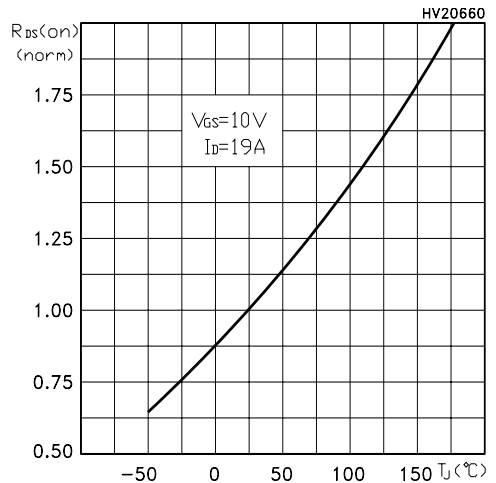

Figure 14: Normalized Breakdown Voltage vs Temperature

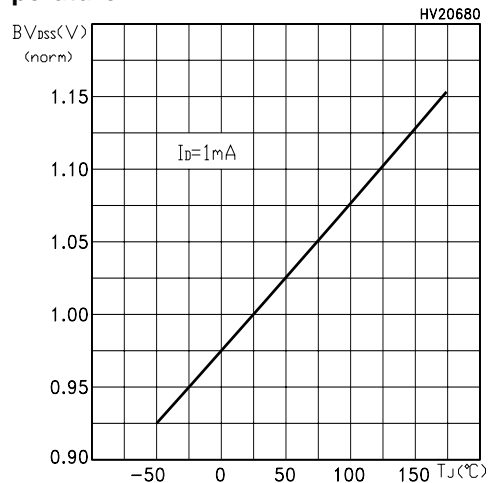

Figure 15: Unclamped Inductive Load Test Circuit

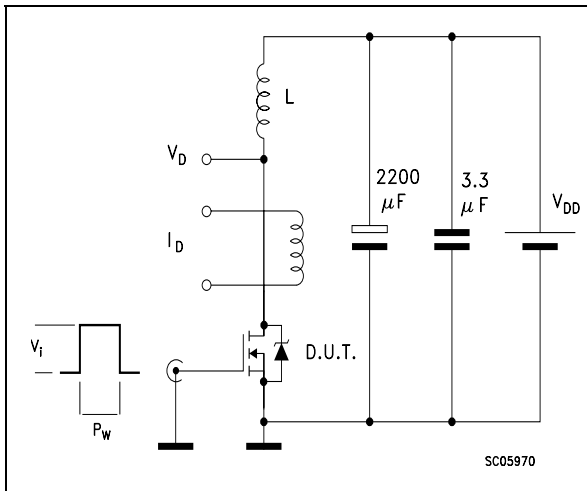

Figure 16: Switching Times Test Circuit For Resistive Load

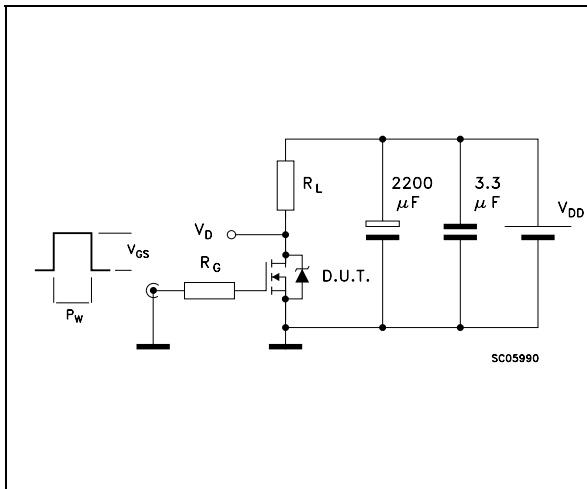

Figure 17: Test Circuit For Inductive Load Switching and Diode Recovery Times

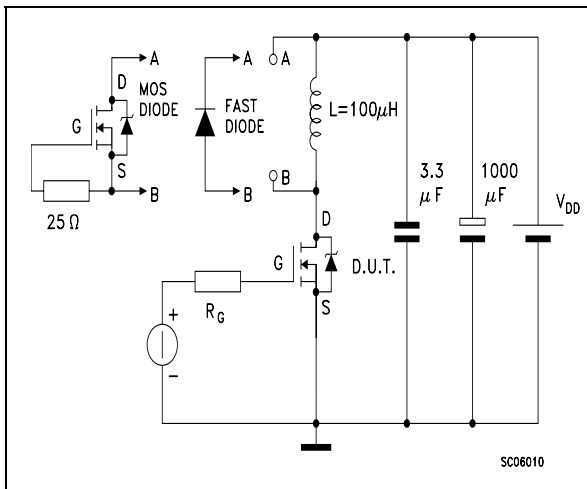

Figure 18: Unclamped Inductive Waferform

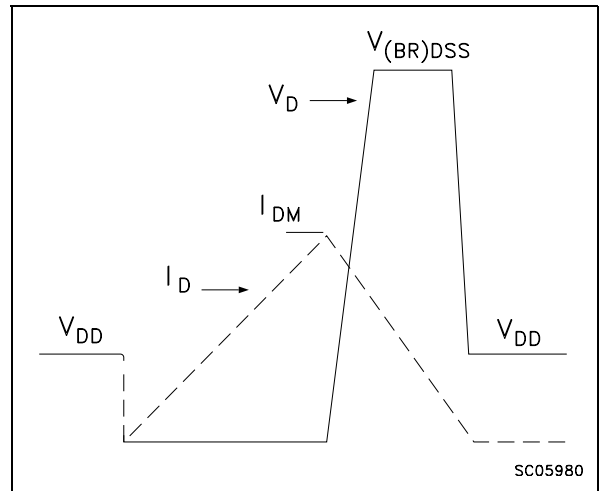

Figure 19: Gate Charge Test Circuit

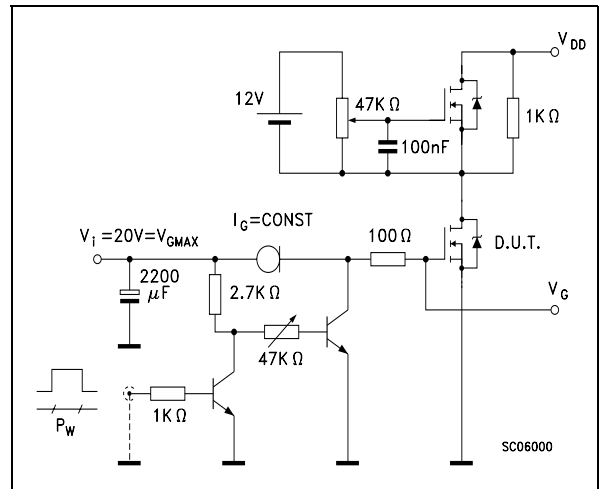
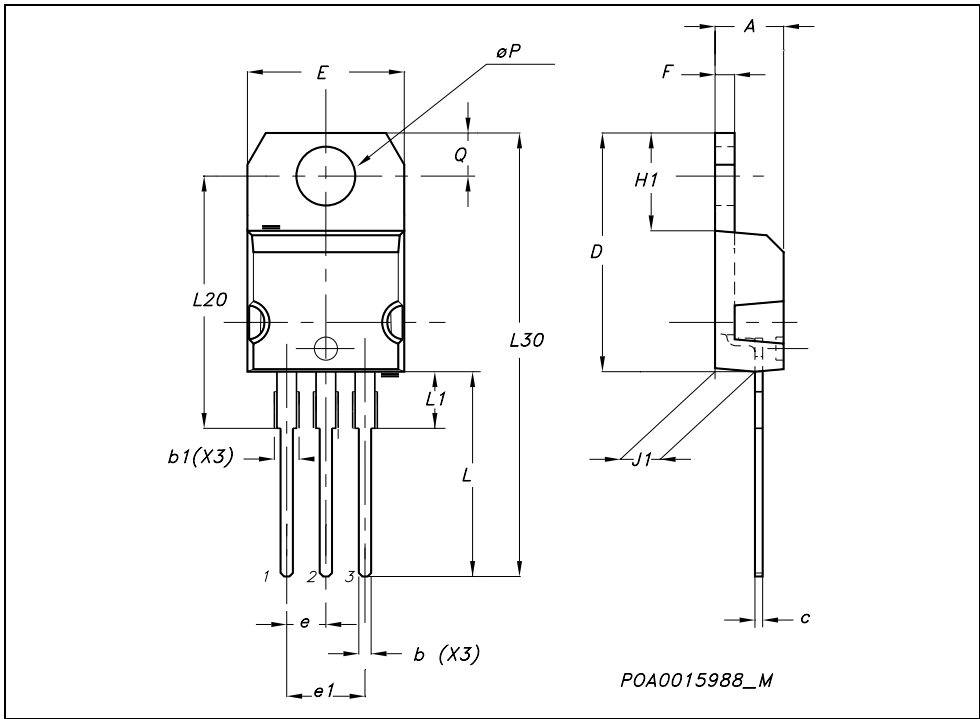

Table 12: Revision History

Date	Revision	Description of Changes
14-June-2004	2	New Stylesheet. No Content Change

TO-220 MECHANICAL DATA

DIM.	mm.			inch		
	MIN.	TYP.	MAX.	MIN.	TYP.	MAX.
A	4.40		4.60	0.173		0.181
b	0.61		0.88	0.024		0.034
b1	1.15		1.70	0.045		0.066
c	0.49		0.70	0.019		0.027
D	15.25		15.75	0.60		0.620
E	10		10.40	0.393		0.409
e	2.40		2.70	0.094		0.106
e1	4.95		5.15	0.194		0.202
F	1.23		1.32	0.048		0.052
H1	6.20		6.60	0.244		0.256
J1	2.40		2.72	0.094		0.107
L	13		14	0.511		0.551
L1	3.50		3.93	0.137		0.154
L20		16.40			0.645	
L30		28.90			1.137	
øP	3.75		3.85	0.147		0.151
Q	2.65		2.95	0.104		0.116



D²PAK MECHANICAL DATA

DIM.	mm.			inch		
	MIN.	TYP	MAX.	MIN.	TYP.	MAX.
A	4.4		4.6	0.173		0.181
A1	2.49		2.69	0.098		0.106
A2	0.03		0.23	0.001		0.009
B	0.7		0.93	0.027		0.036
B2	1.14		1.7	0.044		0.067
C	0.45		0.6	0.017		0.023
C2	1.23		1.36	0.048		0.053
D	8.95		9.35	0.352		0.368
D1		8			0.315	
E	10		10.4	0.393		
E1		8.5			0.334	
G	4.88		5.28	0.192		0.208
L	15		15.85	0.590		0.625
L2	1.27		1.4	0.050		0.055
L3	1.4		1.75	0.055		0.068
M	2.4		3.2	0.094		0.126
R		0.4			0.015	
V2	0°		4°			

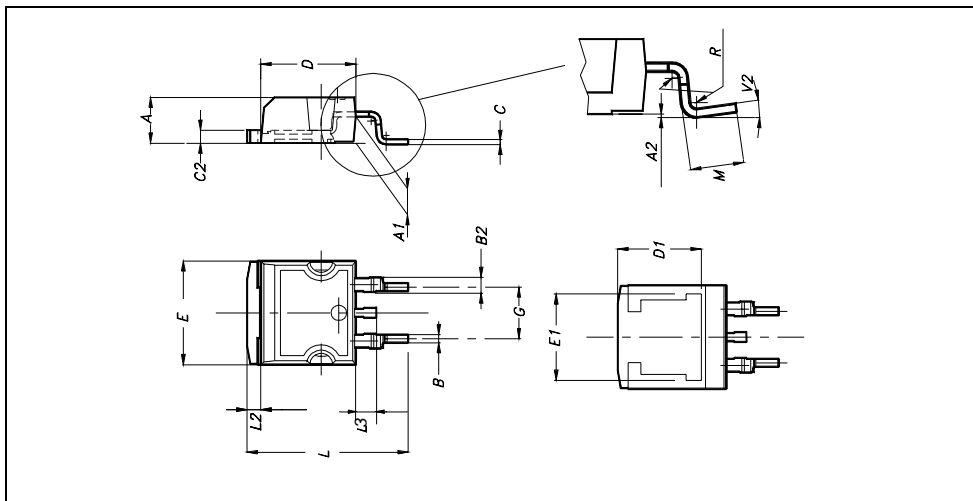

Information furnished is believed to be accurate and reliable. However, STMicroelectronics assumes no responsibility for the consequences of use of such information nor for any infringement of patents or other rights of third parties which may result from its use. No license is granted by implication or otherwise under any patent or patent rights of STMicroelectronics. Specifications mentioned in this publication are subject to change without notice. This publication supersedes and replaces all information previously supplied. STMicroelectronics products are not authorized for use as critical components in life support devices or systems without express written approval of STMicroelectronics.

The ST logo is a registered trademark of STMicroelectronics
All other names are the property of their respective owners

© 2004 STMicroelectronics - All Rights Reserved
STMicroelectronics GROUP OF COMPANIES

Australia - Belgium - Brazil - Canada - China - Czech Republic - Finland - France - Germany - Hong Kong - India - Israel - Italy - Japan - Malaysia - Malta - Morocco - Singapore - Spain - Sweden - Switzerland - United Kingdom - United States.