



Type Z50 LED holder for Philips Lumileds LUXEON® K

The TE Solderless LED Holder, Type Z50, is a circular LED holder that provides a quick and easy solderless connection to the Philips Lumileds LUXEON K 12 and 16 LED array families. TE's Type Z50 holder allows the direct attachment of LUXEON K LEDs to a heat sink using standard screws, which enables designs to be easier to use, and faster to market. The Type Z50 reduces assembly costs and provides a quality solderless power connection, secure mechanical attachment, proper thermal hold down forces, and a landing zone with attachment features for additional secondary optics.

KEY FEATURES

- Snap-in LED retention feature simplifies installation by securing the LED to the holder before mounting
- Poke-in wire connection eliminates time consuming soldering to the LED
- Enables constant thermal down force to minimize influence by thermal plastic deformation at high temperature
- Makes easy and clean thermal paste application possible with built-in excess paste overflow feature
- Provides a specified and stable landing area for additional secondary optics
- Optional alternate mechanical optic attachment accessory
- Minimalistic aesthetic design with clear polarity indication to aid assembly
- Mechanically strong and robust design with negligible light interference
- Available optics from Carclo and LEDIL

APPLICATIONS

- Spotlights
- Down Lights
- Stage lights
- Wall washers
- Architectural lighting

MECHANICAL

- Operating temperature range -40 to 105°C
- Utilize a minimum screw size of #4 or M3 for attachment
- Poke-in style electrical contacts supporting 18-22 AWG (0.35 - 0.75mm²) solid, fused and stranded wire
- Z50 w/ optics attach: 50mm diameter by 6mm high
- Z50 low profile: 45mm by 3.4mm high
- Enables compliancy to Zhaga book 3 standard

ELECTRICAL

- Current rating: 5A
- Voltage rating: 300 VDC
- UL1977 and CSA recognized component (cUR)
- IEC 60838-2-2 (up to 60VDC max)

MATERIALS

- High mechanical strength
- High heat resistance
- Good electrical properties
- UL94V-0 flammability rating

PRODUCT OFFERING

Z50 low profile holder:	2213134-1
Z50 with optic attachment:	2213134-2
Optional:	
Z50 Reflector Optics Retaining Clip Model 1:	2213194-1

APPLICATIONS AND SPECIFICATIONS

- Application Specification #: **114-32048**
- Product Specification #: **108-133008**
- Product Qualification Report #: **501-19197**

PHILIPS
LUMILEDS



PRODUCT DIMENSIONS

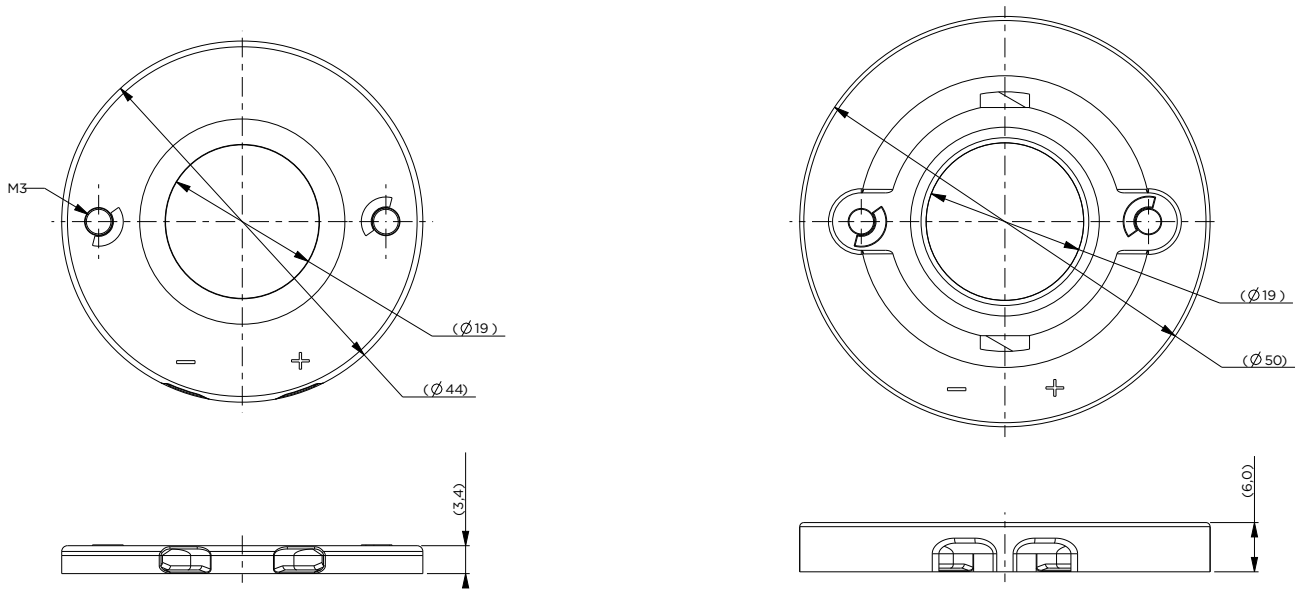

Z50 Low Profile

Z50 with optic attachment features

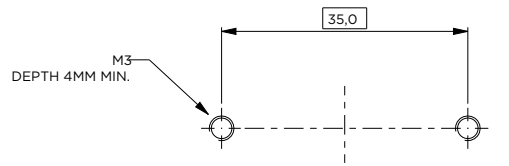

Recommended Mounting Hole Pattern

Available Optics

TE Holder	Optics Partner	Product	Website	TE Attachment Accessory Required
2213134-2		NEWTON Series Reflectors	www.carclo-optics.com	None
2213134-2		ANGELA and ANGELINA Series Reflectors	www.ledil.com	2213194-1 (Reflector Optics Retaining Clip Model 1)

Dimensions are shown for reference purposes only. Specifications subject to change. Customer drawing should be used for all design activity.

