



## Main applications

- Thermostats
- Humidity switches
- Mould cooling units
- Industrial refrigerators
- Air conditioning
- Food processing equipment

## Main features

- Faceplate configurable input
- Protected by a personal code
- Configurable by a serial link
- Transmitter power supply incorporated
- Custom thermocouple linearisation available
- Internal linearisation for engineering units
- Labels provided for the more common physical units
- Sampling time and trip intervention programmable between 15 and 120msec with resolution between 2000 and 8000 steps
- Retransmission of the measured variable signal
- 3 trip points, completely configurable from the faceplate

## GENERAL

Microprocessor based indicator in both 48x48 (1/16 DIN) and 96x48 (1/8 DIN) formats manufactured with SMT.

The instruments have a lexan membrane faceplate (guaranteed to IP65) which has 3 keys, a 3 digit display for the 48x48 format or a 3 / 4 digit display for the 96x48 format, and 3 indicating LED's for the output statuses.

The input signal can be selected from a wide range of sensors:

- Thermocouples of type J, K, R, S, T, B, E, N, L GOST, U, G, D, C
- Resistance thermometers Pt100, Pt100J (japanese standard) 2 / 3 wire
- PTC and NTC themistors
- Linear inputs 0 to 60/12 to 60mV, 0 to 20/4 to 20mA, 0 to 10/2 to 10/0 to 5/1 to 5/0 to 1/0, 2 to 1V

The selection is made using the faceplate keys and correct input terminals.

No external shunt or adapter is required. A digital input (24Vdc/4mA) is available for resetting, hold, flash, peak handling or releasing latch. The instruments have a maximum of 3 outputs that can be mechanical relays (5A/250V) or logic outputs (0 to 11Vdc). One output of 4 to 20mA (max. 150Ω) is available for retransmitting the measured input signal.

The retransmission output, the digital input and the third output are alternatives in the 48x48 format.

All these options are available contemporaneously in the 96x48 format. Finally, a triac can be fitted (as an alternative to the other two relay outputs) to drive resistive loads up to a maximum of 2,5A at 220V.

The programming of the instrument is made easy by grouping the parameters in function blocks (**CFG** for the alarm hysteresis, **Inp** for the inputs, **Out** for the outputs...) and by a simplified data entry menu.

The configuration can be simplified even further using the PC programming kit made up of a connection cable and a menu guide program that runs under Windows (see technical data cod. 80021).

A configurable personal software protection code (password protection) can be used to restrict the levels of editing and displaying the configuration parameters.

## TECHNICAL DATA

### INPUTS

Accuracy 0,2% f.s. ±1 digit.  
Sampling time 120msec for temperature sensors, configurable for linear inputs down to a minimum of 15msec with reduction of the resolution to 2000 steps. Configurable decimal point position for linear inputs, for TC, RTD, PTC and NTC inputs, only one decimal digit is allowed in the maximum display range of -199.9 to 999.9 (4 digit display), -99.9 to 99.9 (3 digit display with sign), with indication of open circuit thermocouple or RTD, PTC or NTC in open or short circuit, indication of over- and under-range for linear inputs.

### TC - Thermocouple (4 digit)

<b>J</b>	0 to 1000°C / 32 to 1832°F
<b>K</b>	0 to 1300°C / 32 to 2372°F
<b>R</b>	0 to 1750°C / 32 to 3182°F
<b>S</b>	0 to 1750°C / 32 to 3182°F
<b>T</b>	-200 to 400°C / -328 to 752°F
<b>B</b>	44 to 1800°C / 111 to 3272°F
<b>E</b>	-100 to 750°C / -148 to 1382°F
<b>N</b>	0 to 1300°C / 32 to 2372°F
<b>L-GOST</b>	0 to 600°C / 32 to 1112°F
<b>U</b>	-200 to 400°C / -328 to 752°F
<b>G</b>	0 to 2300°C / 32 to 4172°F
<b>D</b>	0 to 2300°C / 32 to 4172°F
<b>C</b>	0 to 2300°C / 32 to 4172°F
<b>custom</b>	-1999 to 9999

### TC - Thermocouple

(3 digit + sign [only for 96 format])

J	0 to 999°C / 32 to 999°F
K	0 to 999°C / 32 to 999°F
R	0 to 999°C / 32 to 999°F
S	0 to 999°C / 32 to 999°F
T	-200 to 400°C / -328 to 752°F
B	not available
E	-100 to 750°C / -148 to 999°F
N	0 to 999°C / 32 to 999°F
L-GOST	0 to 600°C / 32 to 999°F
U	-200 to 400°C / -328 to 752°F
G	0 to 999°C / 32 to 999°F
D	0 to 999°C / 32 to 999°F
C	0 to 999°C / 32 to 999°F
custom	-999 to 999

### RTD (2 or 3 wire)

(4 digit)

PT100 -200 to 600°C / -328 to 1112°F  
JPT100 -200 to 600°C / -328 to 1112°F

(3 digit + sign [only for 96 format])

PT100 -200 to 600°C / -328 to 999°F  
JPT100 -200 to 600°C / -328 to 999°F

### PTC

990Ω, 25°C -55 to 120°C / -67 to 248°F

### NTC

1KΩ, 25°C -10 to 70°C / 14 to 158°F

### DC - Linear

With scale configurable within the limits:

-1999 to 9999 (4 digit);

-999 to 999 (3 digit + sign)

0 to 60mV / 12 to 60mV

0 to 10V / 2 to 10V

0 to 5V / 1 to 5V

0 to 1V / 0,2 to 1V

0 to 20mA / 4 to 20mA

Input impedance for voltage signals

Ri > 500KΩ, for current signals Ri = 50Ω.

32-segment configurable linearisation can be used.

### Potentiometer

supply 1,2V >100Ω

### Digital input

Ri = 5,6KΩ (24V, 4mA) isolated to 1500V  
Function is configurable as alarm or memory reset, hold, flash zero, display of the peak value (max., min. or peak to peak).

### OUTPUTS

#### Relay

with NO (NC) contacts rated at 5A, 250V  
at  $\cos\varphi = 1$ .

#### Logic (only for Out1 and Out2)

Output, type D 11Vdc, Rout = 220Ω  
(6V/20mA).

#### Triac (only for 96 format) for Out1,

disabled Out2

24 to 240Vac ±10%, 3A max

Snubberless, I<sup>2</sup>t = 128A<sup>2</sup>sec

A maximum of three trip points can be set as absolute, deviation or symmetrical deviation alarms.

The hysteresis of each alarm is configurable individually.

Alarm masking with exclusion on power up, with memory, delay and minimum intervention time.

The trip point may be set at any point on the scale.

### Retransmission

4 to 20mA on max. 150Ω

### POWER SUPPLY

Standard: 100 to 240Vac/dc ± 10%

optional: 11 to 27Vac/dc ± 10%

0 to 62Hz, max. 3VA

protected by an internal replaceable fuse

### POWER SUPPLY

#### SENSOR/TRANSMITTER

24V ±10% un stabilised, 50mA

15V for transmitter, 50mA

1,2V for potentiometer > 100Ω

### AMBIENT CONDITIONS

Working temperature range: 0 to 50°C

Storage temperature range: -20 to 70°C

Humidity: 20 to 85%Ur non-condensing

### WEIGHT

160g. (48 format), 320g. (96 format) in the complete version

## FACEPLATE DESCRIPTION

A - PV display: indication of process variable

B - Label for engineering units

C - "Function" key

D - "Raise" and "Lower" keys

E - Indication of the states of the outputs

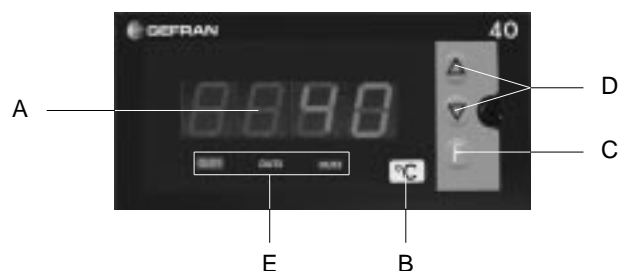
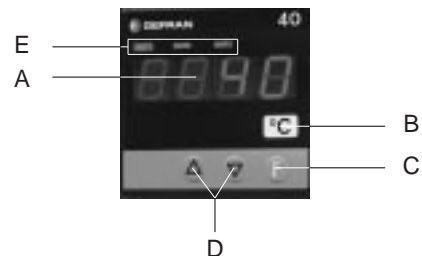

Red LED display

IP65 faceplate protection

## DIMENSIONS and CUT-OUT

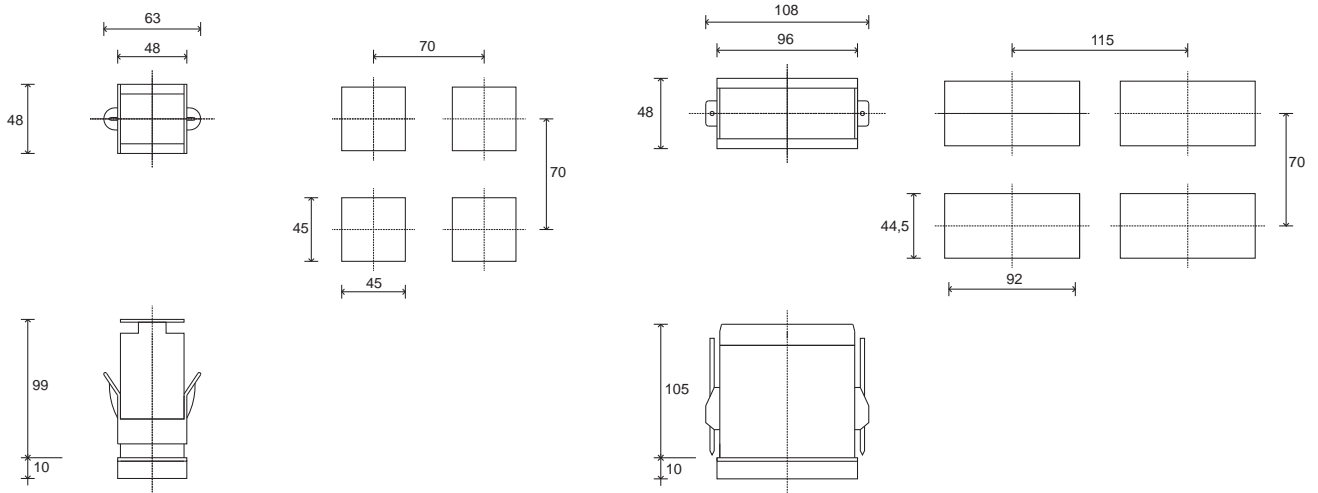

Dimensions: 48x48mm - 96x48mm (1/16DIN - 1/8DIN), depth 99mm - 105mm

## CONNECTION DIAGRAM

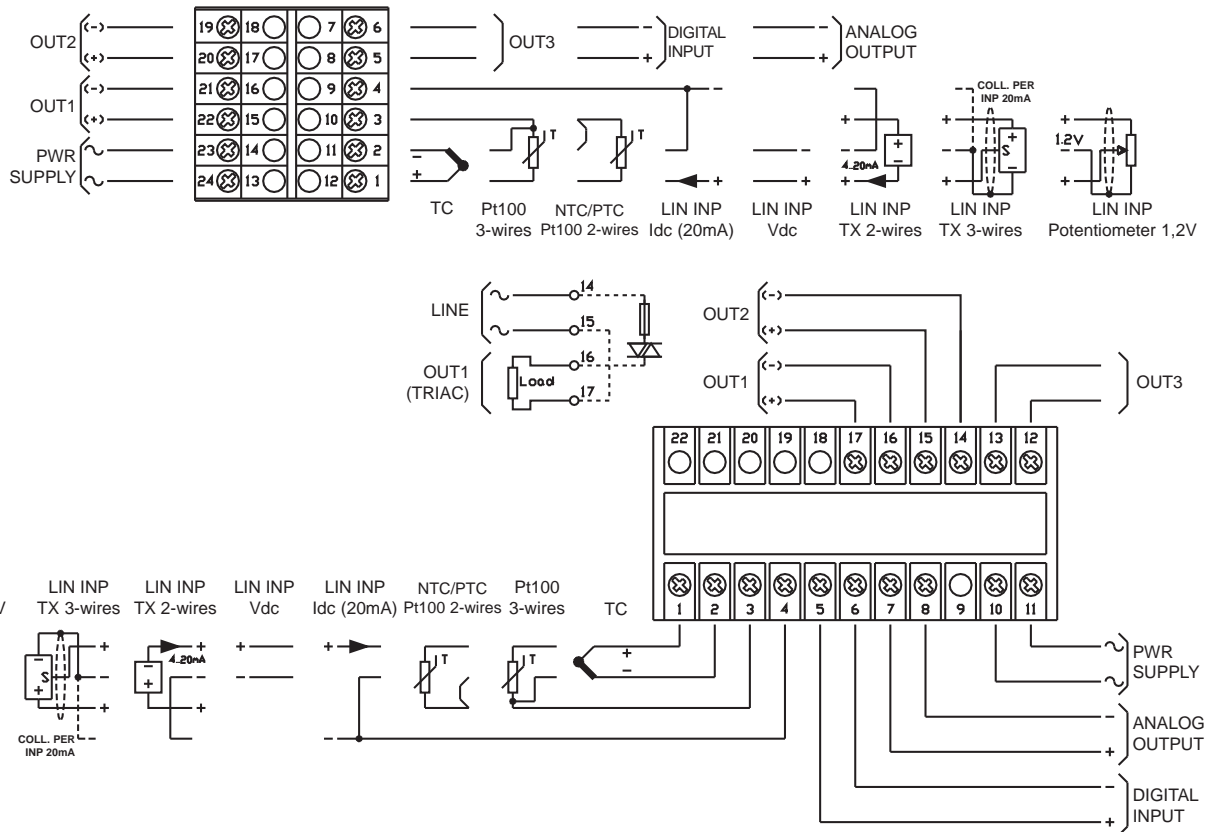

## ORDER CODE

40T



FORMAT	
48 x 48	48
96 x 48	96

NR. DIGITS	
3 + sign (only for 96 format)	3
4	4

SENSOR / TRANSMITTER POWER SUPPLY	
None	0 0
For T input (alternative to RTD, PTC, NTC)	
1,2Vdc for potentiometer	0 1
15Vdc for transmitter	1 5
24Vdc, 50mA	2 4

POWER SUPPLY	
0	11 to 27Vac/dc
1	100 to 240Vac/dc

DIGITAL INPUT / RETRANSMISSION OUTPUT (alternative to output 3 in the 48 format)	
0	None
1	Digital input
2	Retransmission output 4 to 20mA on max 150Ω
3	Both (only for 96 format)

OUTPUT 3 (alternative to digital input / retransmission output on the 48 format)	
0	None
R	Relay

OUTPUT 1, OUTPUT 2	
R R	Relay, Relay
R D	Relay, Static D2
T 0	Triac, None (only for 96 format)

GEFRAN spa reserves the right to make any modification of the design or function, at any moment without prior notice



The instrument conforms to the European Directives 89/336/CEE and 73/23/CEE with reference to the generic standards:  
 - EN 50082-2 (immunity in industrial environments) - EN 50081-1 (emission in residential environments) - EN 61010-1 (safety)



GEFRAN spa via Sebina, 74 - 25050 Provaglio d'Iseo (BS)  
 Tel. 03098881 - fax 0309839063 - Internet: <http://www.gefran.it>

