



Schroff

INPAC

Cabinets 1

Wall mounted cases 2

Accessories for cabinets and wall mounted cases . 3

Climate control . 4

Electronics cases 5

Subracks/
19" chassis 6

Front panels,
plug-in units ... 7

Systems 8

Power supply units 9

Backplanes ... 10

Connectors, front panel component system 11

Appendix 12



02192001



Robust 19" chassis, also for board assembly

02192005

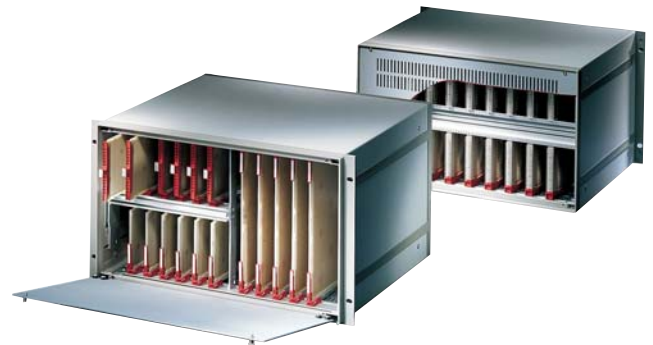

Assembly with boards and hinged front panel

02196001

Standards

- External dimensions in accordance with:
IEC 60297-3-101
- Ingress protection IP 20 to IEC 60529
- GND/earthing connectors to:
DIN EN 50178/VDE 0160
DIN EN 60950/VDE 0805
DIN EN 61010-1/VDE 0411 part 1
DIN EN 61010-1A2/VDE 0411 part 1/A1

19" chassis - *inpac*

Overview 6.128

19" chassis with high mechanical stability

- Also usable as desk-top case
- Robust cases from aluminium die-cast frames to front and rear
- Flexible assembly for standardised board formats or individually, e.g. for mounting plates
- Cost benefit with mounting service and custom processing in ServicePLUS



02192002

19" chassis/desk-top enclosure

- 2 U, 3 U, 4 U and 6 U heights



02192003

inpac built into 19" cabinet

inpac
19" chassis 6.130

Accessories

- Full-width front panels 6.131
- Full-width rear panels 6.131
- Support rails 6.132
- Horizontal rails... 6.132
- Front handles 6.133
- GND/earthing kit 6.133
- Guide rails 6.134
- Dimensions 6.136



30407004

ServicePLUS from page 6.118

- e.g. individual configuration and assembly from 1 piece
- e.g. printing
- e.g. cut-outs in front or rear panels or cover plates
- e.g. modification (special colours)
- e.g. custom solutions (special depths, electromagnetically shielded applications)

www.schroff.biz/ServicePLUS

ServicePLUS... 6.118

19" chassis - *inpac*

19" chassis



- For assembly with 19" components or individually with mounting plates
- Three rows ventilation slots in base for air inlet

Delivery comprises (Kit)

Item	Qty	Description
1	2	Side panel, Al extrusion, RAL 7030, at 6 U: 2 Al corner profiles, 1 divider plate (steel plate)
2	1	Front frame, Al die-cast, RAL 7030, rear side with counterbores for drill holes to mount handles and front panels
3	1	Rear frame, Al die-cast, RAL 7030
4	1	Cover plate, St, 1 mm, RAL 7035, plastic-coated, with GND/earthing connection
5	1	Base plate, St, 1 mm, RAL 7035, plastic-coated, with GND/earthing connection
6	4	Case foot with anti-slip protection, PC, UL 94 V-0
7	1	Assembly kit

02192006

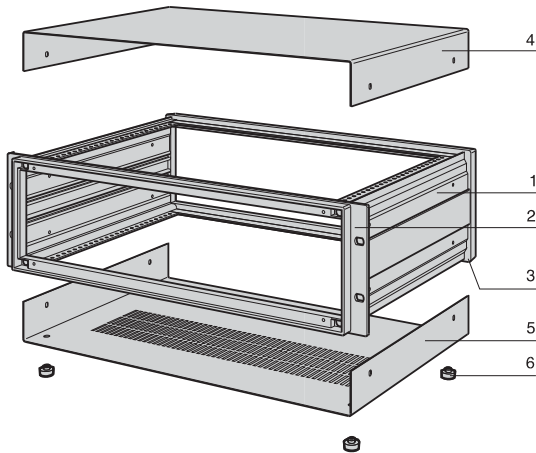

ipa30632

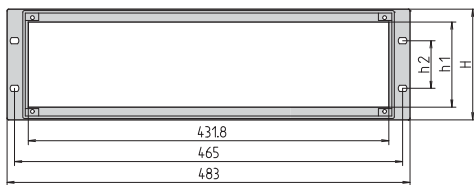

IPA30635

h1 = useable height

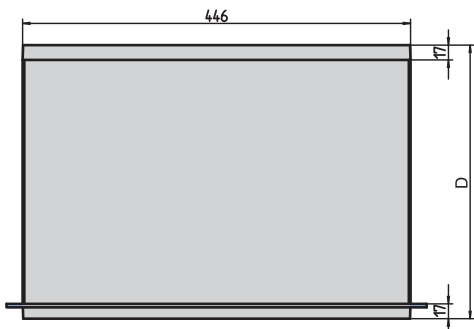

IPA30704



IPA30706

Order Information

Height H	Height H h	h1	h2	Depth D	Part no.
U	mm	mm	mm	mm	
2	88.0	86.0	57.5	254.5	10828-071
2	88.0	86.0	57.5	314.5	10828-072
2	88.0	86.0	57.5	374.5	10828-073
3	132.5	130.5	102.0	254.5	10828-051
3	132.5	130.5	102.0	314.5	10828-052
3	132.5	130.5	102.0	374.5	10828-053
3	132.5	130.5	102.0	434.5	10828-054
4	177.0	174.5	146.5	254.5	10828-056
4	177.0	174.5	146.5	314.5	10828-057
4	177.0	174.5	146.5	374.5	10828-058
4	177.0	174.5	146.5	434.5	10828-059
6	265.9	263.5	235.4	374.5	10828-068
6	265.9	263.5	235.4	434.5	10828-069

Note

- Max. installation space when fitting 19" components is 75 HP
- Scope of delivery includes screws to fix rear and front panels



ServicePLUS see page 6.118

19" chassis - *inpac*

Front panel

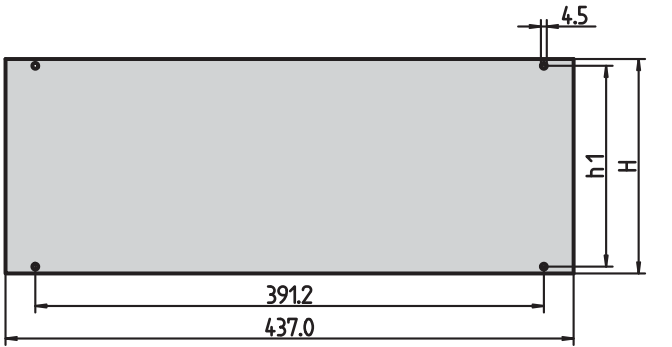

IPA42082

Front panel

Delivery comprises

Item	Qty	Description
1	1	Front panel, Al, 2.5 mm, anodised, cut edges untreated

Order Information

Height U	Height H mm	h1 mm	Part no.
2	76.0	65.6	30828-055
3	120.5	110.0	30828-058
4	165.0	154.5	30828-061
6	253.8	243.4	30828-067

Note

- The assembly kit for the front panel is included with the 19" chassis

Front panel, bottom-hinged

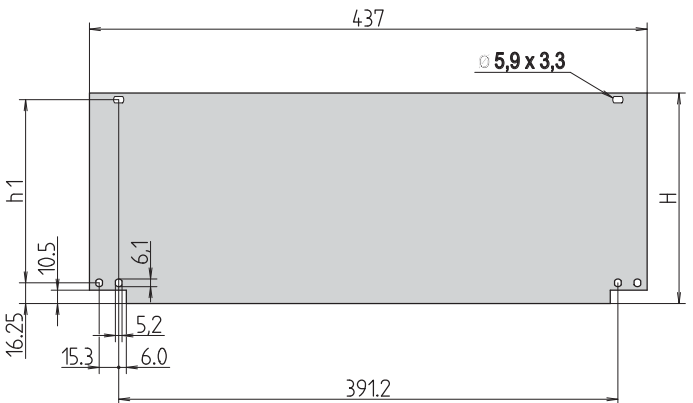

ipa42083

Front panel, bottom-hinged

Delivery comprises

Item	Qty	Description
1	1	Front panel, hinged, Al, 2.5 mm, anodised, cut edges untreated

Order Information

Height U	Height H mm	h1 mm	Part no.
2	76.0	54.5	30828-085
3	120.5	99.0	30828-088
4	165.0	143.5	30828-091
6	253.8	232.3	30828-097

Hinge for front panel PPE, UL 94 V-0, PU 1 kit (includes fixing material kit and 2 collar screws) **20828-028**

Note

- Please order hinge for front panel separately

Rear panel with ventilation openings

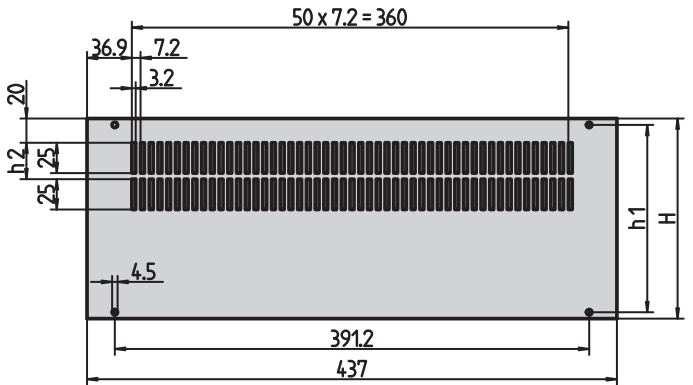

IPA42086

Rear panel with ventilation openings

Delivery comprises (kit)

Item	Qty	Description
1	1	Rear panel, incl. assembly kit, Al, 2.5 mm, anodised, cut edges untreated

Order Information

Height U	Height H mm	h1 mm	h2 mm	Part no.
2	76.0	65.6	-	30828-070
3	120.5	110.0	-	30828-073
4	165.0	154.5	-	30828-076
6	253.8	243.4	30	30828-082

Note

- The scope of delivery of the 19" chassis includes an assembly kit for the front panel

19" chassis - *inpac*

Support rail for guide rails

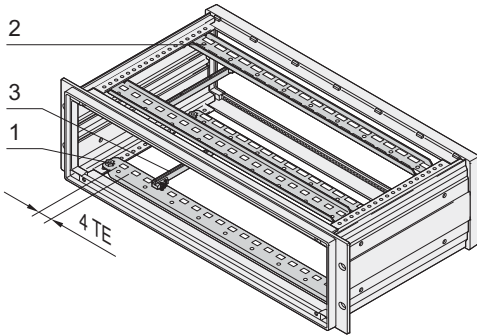

- 4 support rails to fix PCBs with guide rails
- Support rail can also be used to fix a custom mounting plate

Order Information

Item	Description	Part no.
1	front support rail, St, 1.5 mm, blue-passivated, 1 piece	30828-165
2	rear support rail, St, 1.5 mm, blue-passivated, 1 piece	30828-174

Accessories

Guide rail 160 mm (Item 3), PBT, UL 94 V-0, with integrated fixture for connector to EN 60603 (DIN 41612), PU 1 pair **60817-078**

Guide rail 220 mm (Item 3), PBT, UL 94 V-0, with integrated fixture for connector to EN 60603 (DIN 41612), PU 1 pair **60817-079**

Screw for mounting of support rails, M4 × 8, flathead bolts with posidrive, PU 100 pieces **21100-677**

- Guide rails see page 6.134

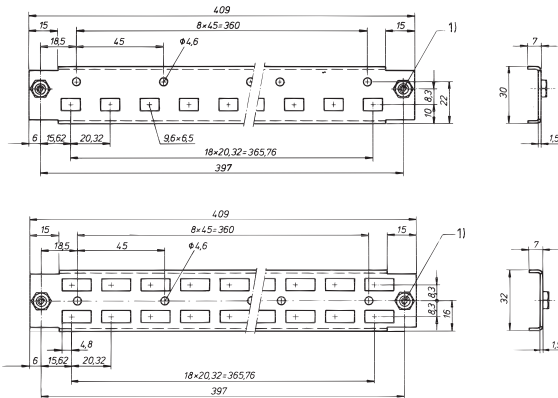

Dimension drawing top: Front support rail,
dimension drawing bottom: rear support rail;
1) bush M4, pressed-in

Horizontal rail for guide rails, backplane and connector mounting

- 4 horizontal rails to fix guide rails (for PCBs) and for backplane or connector mounting
- Useable width 75 HP

Order Information

Item	Description	Qty/PU	Part no.
1	Horizontal rail 75 HP, Al extrusion, anodised	1	30828-128

Accessories

Z-rail (item 2), Al extrusion, anodised, 1 piece **30814-513**

Threaded insert (item 3), St, zinc-plated (blue), 1 piece **30819-604**

Screw to fix horizontal rails, M4 × 8, Pozidrive flathead screw, 100 pieces **21100-677**

Cheesehead screw with slot M2.5 × 6, DIN 84, PU 100 pieces M2.5 × 6, DIN 84, 100 pieces **21100-146**

Note

- Threaded inserts cannot be used at front
- For backplane mounting, threaded inserts are required in the rear horizontal rails
- For connector mounting, threaded inserts and Z-rails are required in the rear horizontal rails
- Guide rails see page 6.134

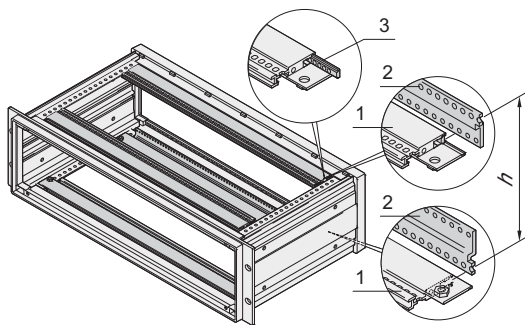

Item 1: horizontal rail, item 2: Z-rail, item 3: threaded insert

h	Bolt-on dimension of backplane
2	75.40
3	119.80
4	164.30
6	252.90

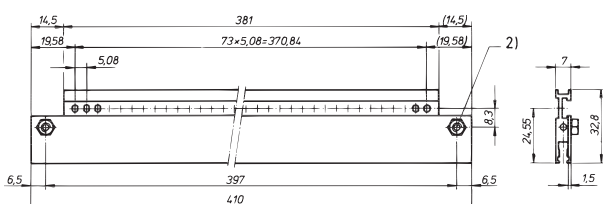

2) bush M4, pressed-in

19" chassis - *inpac*

Front handles

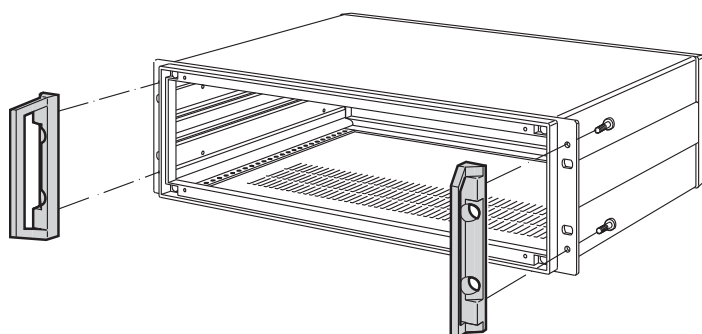

IPA30636

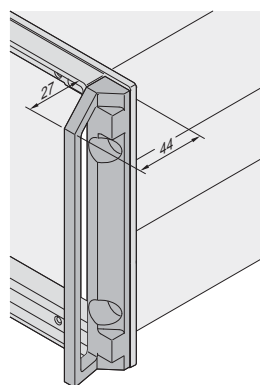

02108050

- Load-carrying capacity 35 kg per pair

Delivery comprises (kit)

Item	Qty	Description
1	2	Front handle, Al die-cast, powder-coated, RAL 7030, incl. assembly kit

Order Information

Height	Part no.
U	
3	20828-127
4	20828-128
6	20828-129

GND/earthing kit

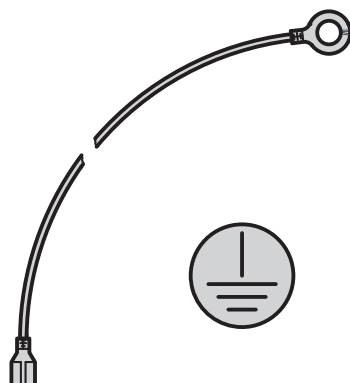

aza43284

- The GND/earthing kit allows VDE-compliant earthing of the case to:

- DIN EN 50178/VDE 0160
- DIN EN 60950/VDE 0805
- DIN EN 61010-1/VDE 0411 Part 1
- DIN EN 61010-1A2/VDE 0411 Part 1/A

- VDE inspection has been carried out

Order Information

Description	Qty/PU	Part no.
GND/earthing kit, Cu wire, 1.5 mm ² , PVC sleeve, green/yellow, links side panels, top cover, base plate and rear panel	1	21100-814



19" chassis - *inpac*

Guide rails

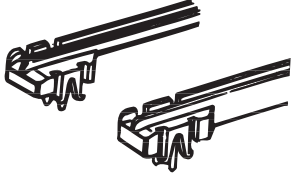
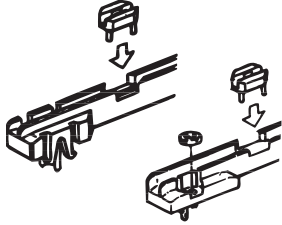

04292012

Order Information

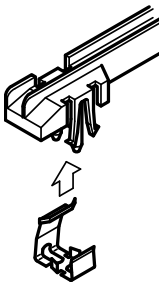
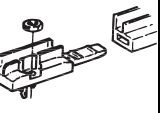
Board lengths mm mm	Groove width mm mm	 <small>a4-2744X</small> Light version, snap-in		 <small>A42744b</small> Version with board fixing, snap-in		 <small>a42744c</small> Version for heavy load-carrying capacity, snap-in		 <small>bzm44267</small> Version with ESD clip		 <small>a4-2744d</small> Universal version with Al middle section, bolt-on	
		Part no.	Part no.	Part no.	Part no.	Part no.	Part no.	Part no.	Part no.		
		1 piece (SPQ 50) ¹⁾	1 piece (SPQ 50) ¹⁾	1 piece (SPQ 50) ¹⁾	1 piece (SPQ 50) ¹⁾	1 piece (SPQ 50) ¹⁾	Qty/PU 1 piece	Qty/PU 1 piece			
100	2	-	60817-015	-	-	-	-	-	-	-	
160	2	60817-064	60817-103	60817-001	60817-053	60817-102	20817-368	-	-	-	
160	2.5	-	60817-076	-	-	-	-	-	-	-	
180	2	-	-	60817-026	-	-	-	-	-	-	
220	2	-	60817-149	60817-016	60817-083	60817-085	20817-369	-	-	-	
220	2.5	-	-	-	-	60817-098	-	-	-	-	
280	2	-	-	-	-	60817-080	-	-	-	-	
340	2	-	-	-	-	-	-	-	-	20825-120	
400	2	-	-	-	-	-	-	-	-	20825-121	

1) SPQ (standard pack quantity): Part number includes 1 piece, but delivery is exclusively made in standard pack quantity (SPQ); please order at least the SPQ quantity or a multiple

Accessories

Spring clip PPE, UL 94 V-0, red, PU 10 pieces	21100-553	21100-553	-	-	-
Spring clip PPE, UL 94 V-0, red, PU 100 pieces	21100-554	21100-554	-	-	-
Assembly parts for 50 guide rails PU (100 screws, 100 nuts)	-	21101-990	-	-	21101-990

Note

- For a detailed description of the guide rails see our website; please enter part number in "oneclick" search

19" chassis - *inpac*

PCB handle A

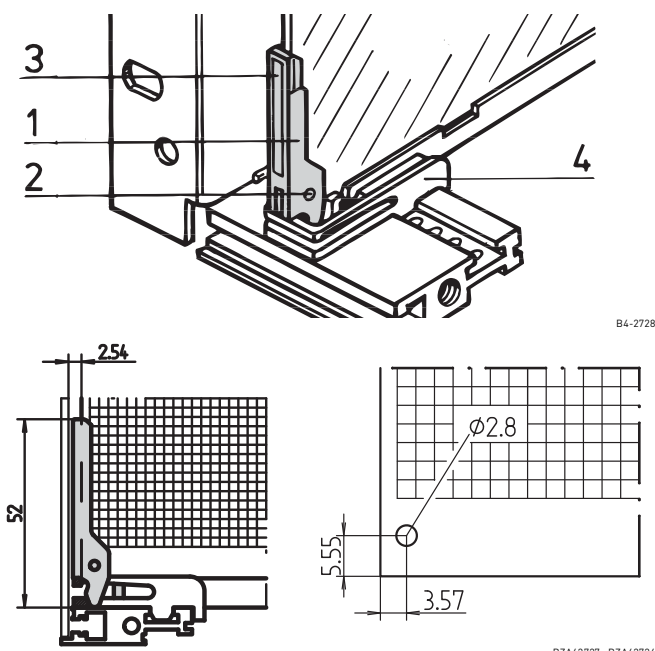

B4-2728

BZA42721 BZA42724

- To be mounted behind front panel, for PCB thickness 1.6 mm
- Insertion and extraction function
- Can be labelled

Order Information

Item	Description	Material	Colour	Qty/PU	Part no.
1	PCB handle A	PBT, UL 94 V-0	red	1 piece (SPQ 10)	60817-096
2	Pivot pin DIN 7	Stainless steel	-	100	21100-671
3	Identification strip	Polyester film, matt-self-adhesive	silver	100	21100-672

SPQ (Standard Pack Quantity): Part number includes 1 piece, but delivery is exclusively made in standard pack quantity: Please order at least 10 pieces PCB handles or a multiple

PCB retainer A

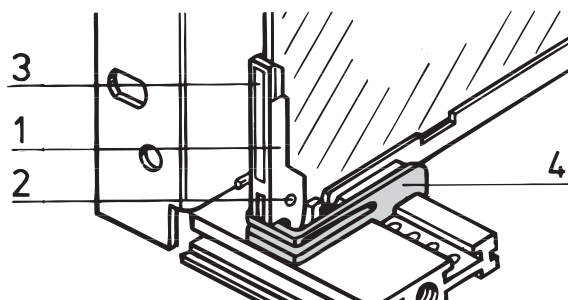

C4-2728

- Can also be used without PCB handle
- Application on top and bottom horizontal rail

Order Information

Item	Description	Material	Colour	Qty	Part no.
4	PCB retainer A for top and bottom	PPE, UL 94 V-0	red	1 piece (SPQ 10)	60817-097

SPQ (Standard Pack Quantity): Part number includes 1 piece, but delivery is exclusively made in Standard Pack Quantity: Please order at least 10 pieces PCB retainers or a multiple

PCB retainer B

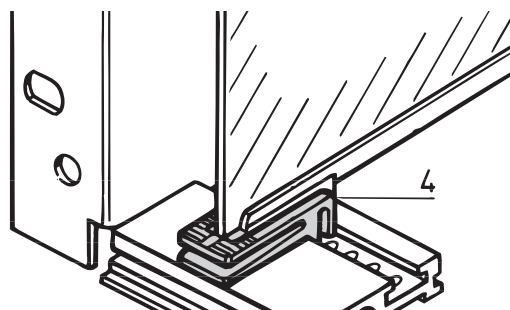

BZA44428

- Can be used on upper and lower horizontal rail, for PCB thickness 1.6 mm
- Can also be used without PCB handle
- Can also be used with guide blocks

Order Information

Item	Description	Material	Colour	Qty	Part no.
4	PCB retainer, bottom	PPE, UL 94 V-0	red	1 piece (SPQ 10)	60817-054
4a	PCB securing top	PPE, UL 94 V-0	black	1 piece (SPQ 10)	60817-071

SPQ (Standard Pack Quantity): Part number includes 1 piece, but delivery is exclusively made in Standard Pack Quantity: Please order at least 10 pieces PCB retainers or a multiple

19" chassis - *inpac*

Dimensions

19" front frame

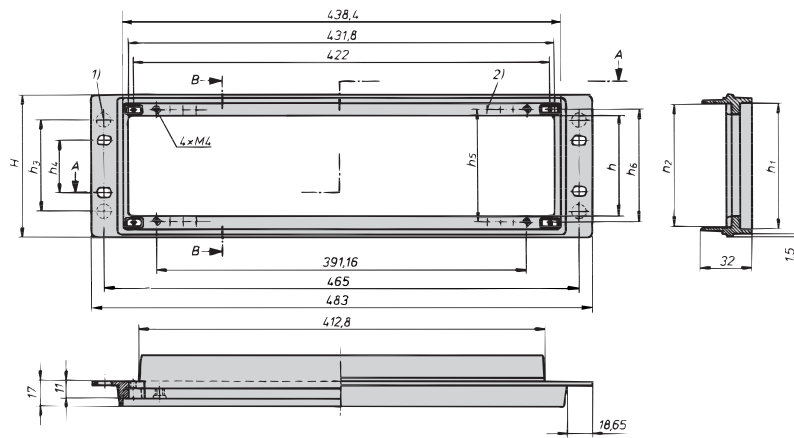

Section A-A

There are counterbores at the rear side of the front frame which can be drilled if required:

- 1) For handle mounting
- 2) For mounting of partial-width front panel (grid 5.08 mm)

19" rear frame

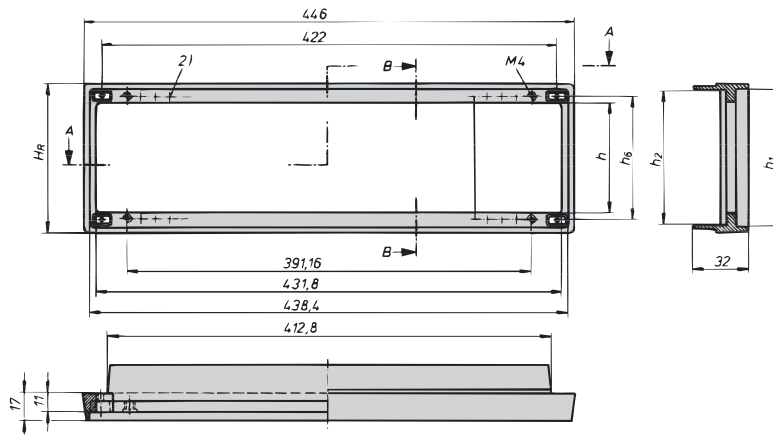

Section A-A

Dimensions table

Height in U	H	H _R	h	h ₁	h ₂	h ₃	h ₄	h ₅	h ₆	h ₇
2	88,0	86,0	57,5	77,3	69,8	25,0	76.2	65,5	68,0	68,4
3	132.5	130.5	102.5	121.8	114.3	90,0	57.1	110.0	112,5	112.8
4	177.0	175.0	146.5	166.3	158.8	134.5	101.6	154.5	157,0	157.3
6	265.9	263.9	235.4	255.2	247.7	233.4	190.4	243.4	245,9	245,9

19" chassis - *inpac*

Dimensions

Side panel

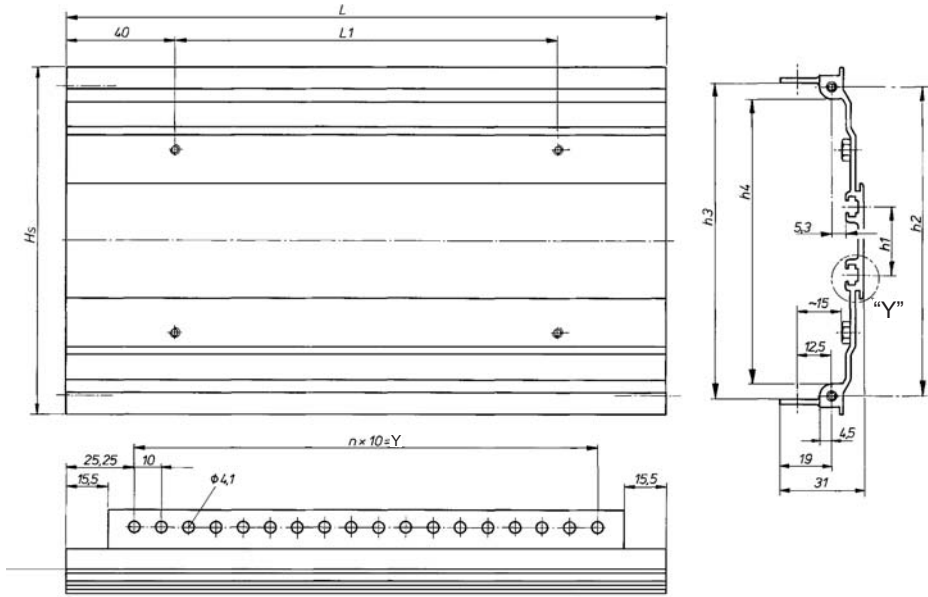

A3--304a

Detail "Y"

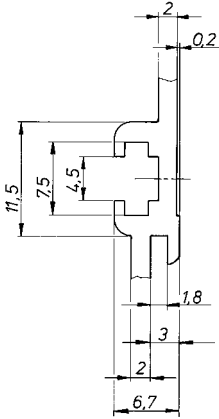

A3--304b

Dimensions table

Height										
in U	H	h ₁	h ₂	h ₃	h ₄	L	L ₁	(n)	Y	T
2	82,6	-	68,0	71,4	59,0	220,5	140,5	17,0	170	254,5
2	82,6	-	68,0	71,4	59,0	280,5	200,5	23,0	230	314,5
2	82,6	-	68,0	71,4	59,0	340,5	260,5	29,0	290	374,5
3	127,0	24,0	112,5	115,8	103,5	220,5	140,5	17,0	170	254,5
3	127,0	24,0	112,5	115,8	103,5	280,5	200,5	23,0	230	314,5
3	127,0	24,0	112,5	115,8	103,5	340,5	260,5	29,0	290	374,5
4	171,0	68,5	157,0	160,3	148,0	220,5	140,5	17,0	170	254,5
4	171,0	68,5	157,0	160,3	148,0	280,5	200,5	23,0	230	314,5
4	171,0	68,5	157,0	160,3	148,0	340,5	260,5	29,0	290	374,5
6	260,4	157,1	245,9	248,9	236,5	220,5	140,5	17,0	170	254,5
6	260,4	157,1	245,9	248,9	236,5	280,5	200,5	23,0	230	314,5
6	260,4	157,1	245,9	248,9	236,5	340,5	260,5	29,0	290	374,5

Appendix – Order notes

Packaging units

A packaging unit (PU) - e.g. carton, bag - contains the stated quantity. If you order the quantity 1, you will automatically receive the quantity defined as PU.

Example: EMC textile gasket
See page 5.22
Part number 21101-853

Quantity (per part number): 10 pieces

Order quantity: Delivery quantity:

1	10 pieces
2	20 pieces
3	30 pieces

Price list

Our price list is available by e-mail from your customer consultant. Please find all contact details at www.schroff.biz/contact.

Always up-to-date

Please visit our website www.schroff.biz where we continuously inform about news and technical changes.

Quick links

Catalogue request: www.schroff.biz/catalogues

Product configurators: www.schroff.biz/conf

Contact details: www.schroff.biz/contact

Product search: www.schroff.biz/oneclick

Front Panel Express: www.frontpanelexpress.eu

VARISTAR: www.varistar.co.uk

Railway technology: www.schroff.co.uk/railway

IT Infrastructure: www.schroff.co.uk/datacom

Standard pack quantity (SPQ)

Please take into consideration that deliveries may be carried out in the stated SPQs (SPQ, e.g. 5 pieces, 10 pieces, 50 pieces, etc.). Differing order quantities (e.g. 2 pieces) may be changed to the next possible delivery quantity = Standard Pack Quantity (in this case 10 pieces).

Example: Front horizontal rail
See page 5.31
Part number 34560-228

Quantity (per part number): 1 piece
Standard pack quantity (SPQ): 10 pieces

Order quantity: Delivery quantity:

≤ 10	10 pieces
> 10 ≤ 20	20 pieces
> 20 ≤ 30	30 pieces

Delivery times

Part numbers in bold face type are ready for despatch within 2 working days; part numbers in normal type are ready for despatch within 10 working days.

Business relations

Schroff is exclusively operating in Business to Business (B2B). Private individuals can buy Schroff products via our sales representatives (see www.schroff.biz/contact).

Responsible for contents and print

Schroff GmbH, Marketing Communication,
D-75334 Straubenhardt, Germany

The data in this catalogue have been thoroughly edited and checked - in assistance with an accredited Quality Management System in accordance with EN ISO 9001:2008.

Faults and spelling mistakes, but mainly changes due to improvements and further developments of our products are subject to change. There is no possibility to claim indemnity/compensation.

Cabinets	Overview.....	1.0	LHX 20/40 Air/water heat exchangers.....	1.224	1
	Varistar Cabinet platform.....	1.2	LHX 3 Air/water heat exchangers.....	1.236	
	Varistar Electronics.....	1.10	Novastar.....	1.240	
	Varistar EMC.....	1.54	Eurorack.....	1.270	
	Varistar Seismic.....	1.84	Outdoor.....	1.316	
	Varistar MIL.....	1.120	Etsirack.....	1.346	
	Varistar Data/network systems.....	1.124	19" lab racks.....	1.354	
	Varistar Containment.....	1.202	PROLINE.....	1.362	
Wall mounted case	Overview.....	2.0			2
	Epcase.....	2.36			
	LAN wall-mounted distributors.....	2.46			
Cabinet and wall-mounted case accessories	Overview.....	3.0	Monitors, keyboards, monitoring.....	3.44	3
	Mechanics.....	3.2	Socket strips.....	3.50	
	Telescopic slides.....	3.24	Power control socket strips.....	3.72	
	Electrical.....	3.29			
Climate control	Overview.....	4.0	Accessories.....	4.58	4
	Cooling concepts/service.....	4.2			
	19" fan trays.....	4.4			
	Air filtered fans.....	4.20			
Desktop enclosures	Overview.....	5.0	Comptec.....	5.100	5
	RatiopacPRO.....	5.6	Accessories.....	5.108	
	PropacPRO.....	5.44	Interscale.....	5.200	
	CompacPRO.....	5.76	Minipac.....	5.230	
Subracks/ 19" chassis	Overview.....	6.0	EuropacPRO industrial applications.....	6.86	6
	EuropacPRO.....	6.2	EuropacPRO Rugged.....	6.92	
	EuropacPRO for railroad applications.....	6.70	MultipacPRO.....	6.112	
			Inpac.....	6.128	
Front panels, Plug-in-units, Frame type plug-in-units	Overview.....	7.0	PCB accessories.....	7.102	7
	Front panels.....	7.2			
	Plug-in units.....	7.16			
	Frame type plug-in units.....	7.64			
Systems	Overview.....	8.0	AdvancedMC modules.....	8.56	8
	AdvancedTCA.....	8.2	CompactPCI, Serial, PlusIO, PSB.....	8.68	
	AdvancedMC carriers.....	8.26	VME, VME64x, VXS, VPX.....	8.88	
	MicroTCA.....	8.36	Accessories.....	8.106	
Power supply systems	Overview.....	9.0	19" accessories.....	9.18	9
	19" AC/DC switched-mode PSUs.....	9.2	PSUs for MicroTCA.....	9.20	
	19" AC/DC linear regulators.....	9.12	PSUs for VMEbus.....	9.22	
	19" AC/DC convertors.....	9.15	PSUs for CompactPCI, VME64x.....	9.24	
Backplanes	Overview.....	10.0	VME64x, VMEbus.....	10.15	10
	CompactPCI, Serial, PlusIO.....	10.4	Power.....	10.18	
	PXI.....	10.11	Universal.....	10.19	
	VXS.....	10.14	Test adaptors.....	10.20	
Connectors, Front panel component systems	Overview.....	11.0			11
	Connectors.....	11.2			
	Front panel component system.....	11.12			
Appendix	Standards abbreviations.....	12.0			12
	Notes on ordering.....	12.10			
	Order number index.....	12.11			
	Product index.....	12.62			