

Solderless terminals

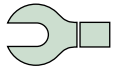

# FORK TONGUE (X type) Non-insulated

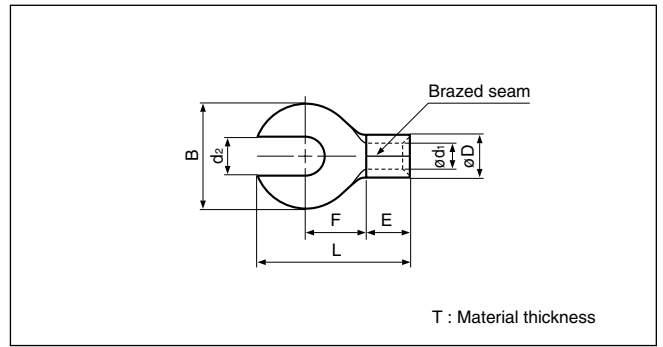
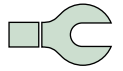

Certificate No.: E42024 LR20812

Applicable Wire AWG#(mm <sup>2</sup> )	Stud size		Part No.	Standard	Dimensions mm (in.)								Tool No.	Qty/box
	American	Metric			d <sub>2</sub>	B	L	F	E	ø D	ø d <sub>1</sub>	T		
26 to 22 (0.2 to 0.5)	1-2	2	0.5-2X		2.2 (.087)	5.2 (.205)	12.1 (.476)	5.8 (.228)	4.0 (.157)	2.0 (.079)	1.0 (.039)	0.5 (.020)	YHT-2622 YA-1 YA-2 BCT-0514	1,000
	3-4	3	0.5-3X		3.2 (.126)	5.2 (.205)	11.8 (.465)	5.8 (.228)						
	5-6	3.5	0.5-3.7X		3.7 (.146)	6.6 (.260)	14.4 (.567)	7.7 (.303)						
	8	4	0.5-4X		4.3 (.169)	6.6 (.260)	14.2 (.559)	7.7 (.303)						
22 to 16 (0.25 to 1.65)	1-2	2	1.25-2X		2.2 (.087)	5.5 (.217)	11.2 (.441)	4.0 (.157)	4.8 (.189)	3.4 (.134)	1.7 (.067)	0.8 (.031)	YHT-2210 YA-1 YA-2 YA-4 BCT-0514	1,000
	3-4	3	1.25-3X		3.2 (.126)	5.5 (.217)	11.0 (.433)	4.0 (.157)						
	3-4	3	1.25-L3X		3.2 (.126)	8.0 (.315)	15.5 (.610)	7.0 (.276)						
	5-6	3.5	1.25-3.7X		3.7 (.146)	5.5 (.217)	10.8 (.425)	4.0 (.157)						
	5-6	3.5	1.25-M3X		3.7 (.146)	6.6 (.260)	13.8 (.543)	6.3 (.248)						
	8	4	1.25-M4X		4.3 (.169)	6.6 (.260)	13.6 (.535)	6.3 (.248)						
	8	4	1.25-4X		4.3 (.169)	8.0 (.315)	15.2 (.598)	7.0 (.276)						
	10	5	1.25-5X		5.3 (.209)	8.0 (.315)	14.8 (.583)	7.0 (.276)						
	1/4	6	1.25-6X		6.4 (.252)	11.6 (.457)	20.7 (.815)	11.1 (.437)						
	5/16	8	1.25-8X		8.4 (.331)	11.6 (.457)	19.8 (.780)	11.1 (.437)						
3/8	10	1.25-10X	10.5 (.413)	13.6 (.535)	23.0 (.906)	13.9 (.547)								
16 to 14 (1.04 to 2.63)	1-2	2	2-S2X		2.2 (.087)	6.4 (.252)	12.1 (.476)	4.3 (.169)	4.8 (.189)	4.1 (.161)	2.3 (.091)	0.8 (.031)	YHT-2210 YA-1 YA-2 YA-4 BCT-0514	1,000
	3-4	3	2-S3.3X		3.2 (.126)	6.4 (.252)	11.9 (.469)	4.3 (.169)						
	5-6	3.5	2-S3X		3.7 (.146)	6.4 (.252)	11.7 (.461)	4.3 (.169)						
	5-6	3.5	2-M3X		3.7 (.146)	6.6 (.260)	13.7 (.540)	6.3 (.248)						
	8	4	2-M4X		4.3 (.169)	6.6 (.260)	13.5 (.531)	6.3 (.248)						
	8	4	2-4X		4.3 (.169)	8.5 (.335)	16.2 (.638)	7.8 (.307)						
	10	5	2-M5X		5.3 (.209)	8.5 (.335)	15.9 (.626)	7.8 (.307)						
	10	5	2-5X		5.3 (.209)	9.5 (.374)	16.0 (.630)	7.3 (.287)						
	1/4	6	2-6X		6.4 (.252)	12.0 (.472)	20.8 (.819)	11.0 (.433)						
	5/16	8	2-8X		8.4 (.331)	12.0 (.472)	20.1 (.791)	11.0 (.433)						
	3/8	10	2-10X		10.5 (.413)	13.6 (.535)	23.0 (.906)	13.9 (.547)						
	12 to 10 (2.63 to 6.64)	3-4	3		5.5-3X		3.2 (.126)	9.5 (.374)						
5-6		3.5	5.5-S3X	3.7 (.146)	7.2 (.284)		15.2 (.598)	5.9 (.232)						
8		4	5.5-S4X	4.3 (.169)	7.2 (.284)		15.0 (.591)	5.9 (.232)						
8		4	5.5-4X	4.3 (.169)	9.5 (.374)		19.3 (.560)	8.3 (.327)						
10		5	5.5-5X	5.3 (.209)	9.5 (.374)		19.0 (.748)	8.3 (.327)						
10		5	5.5-S5X	5.3 (.209)	13.2 (.520)		21.8 (.858)	9.0 (.354)						
1/4		6	5.5-6X	6.4 (.252)	12.0 (.472)		24.8 (.976)	13.0 (.512)						
1/4		6	5.5-S6X	6.4 (.252)	13.2 (.520)		21.5 (.846)	9.0 (.354)						
5/16		8	5.5-S8X	8.4 (.331)	13.2 (.520)		20.9 (.823)	9.0 (.354)						
5/16		8	5.5-8X	8.4 (.331)	15.0 (.591)		26.7(1.051)	13.7 (.539)						
3/8		10	5.5-10X	10.5 (.413)	15.0 (.591)		25.9(1.020)	13.7 (.539)						

Note:1) The part numbers indicated in the above table are for products with a brazed seam.  
 When ordering products with a butted seam, add the prefix "WS" to the part number (ex. 2-5X -->WS2-5X).  
 2) Delivery lead times may vary depending on the product. Contact JST for details.

Solderless terminals

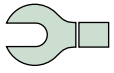

# FORK TONGUE (X type) Vinyl-insulated

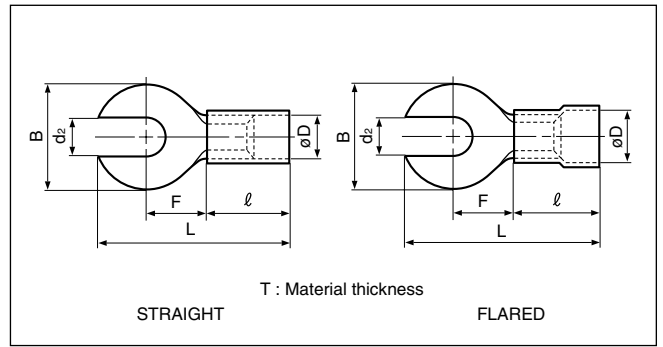
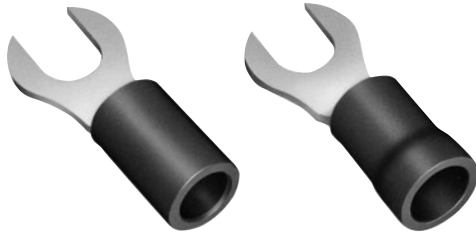
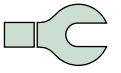

Certificate No.:

Applicable Wire AWG#(mm <sup>2</sup> )	Stud size		Part No.		Standard	Dimensions mm (in.)										Color	Tool No.	Qty/box
	American	Metric	Straight	Flared		d <sub>2</sub>	B	L	F	ℓ	ø D		T					
											Str.	Fld.						
26 to 22 (0.2 to 0.5)	1-2	2	V0.5-2X	FV0.5-2X		2.2 (.087)	5.2 (.205)	16.1 (.634)	5.8 (.228)	8.0 (.315)	1.9 (.075)	2.9 (.114)	0.5 (.020)	Yellow	YNT-2622 YA-1 YA-2 BCT-0514	1,000		
	3-4	3	V0.5-3X	FV0.5-3X		3.2 (.126)	5.2 (.205)	15.8 (.622)	5.8 (.228)									
	5-6	3.5	V0.5-3.7X	FV0.5-3.7X		3.7 (.146)	6.6 (.260)	18.4 (.724)	7.7 (.303)									
	8	4	V0.5-4X	FV0.5-4X		4.3 (.169)	6.6 (.260)	18.2 (.717)	7.7 (.303)									
	10	5	V0.5-5X	FV0.5-5X		5.3 (.209)	8.0 (.315)	18.0 (.709)	7.0 (.276)									
22 to 16 (*0.25 to 1.65)	1-2	2	V1.25-2X	FV1.25-2X		2.2 (.087)	5.5 (.217)	15.4 (.606)	4.0 (.157)	9.0 (.354)	3.2 (.126)	4.0 (.157)	0.8 (.031)	Red	YNT-2216 YA-1 YA-2 YA-4 BCT-0514	1,000		
	3-4	3	V1.25-3X	FV1.25-3X		3.2 (.126)	5.5 (.217)	15.2 (.598)	4.0 (.157)									
	3-4	3	V1.25-L3X	FV1.25-L3X		3.2 (.126)	8.0 (.315)	19.7 (.776)	7.0 (.276)									
	5-6	3.5	V1.25-3.7X	FV1.25-3.7X		3.7 (.146)	5.5 (.217)	15.0 (.591)	4.0 (.157)									
	5-6	3.5	V1.25-M3X	FV1.25-M3X		3.7 (.146)	6.6 (.260)	18.0 (.709)	6.3 (.248)									
	8	4	V1.25-M4X	FV1.25-M4X		4.3 (.169)	6.6 (.260)	17.8 (.701)	6.3 (.248)									
	8	4	V1.25-4X	FV1.25-4X		4.3 (.169)	8.0 (.315)	19.4 (.764)	7.0 (.276)									
	10	5	V1.25-5X	FV1.25-5X		5.3 (.209)	8.0 (.315)	19.0 (.748)	7.0 (.276)									
	1/4	6	V1.25-6X	FV1.25-6X		6.4 (.252)	11.6 (.457)	24.9 (.980)	11.1 (.437)									
	5/16	8	V1.25-8X	FV1.25-8X		8.4 (.331)	11.6 (.457)	24.0 (.945)	11.1 (.437)									
3/8	10	V1.25-10X	FV1.25-10X	10.5 (.413)	13.6 (.535)	27.2(1.071)	13.9 (.547)											
16 to 14 (1.04 to 2.63)	1-2	2	V2-S2X	FV2-S2X		2.2 (.087)	6.4 (.252)	16.3 (.642)	4.3 (.169)	9.0 (.354)	3.9 (.154)	4.5 (.177)	0.8 (.031)	Blue	YNT-1614 YA-1 YA-2 YA-4 BCT-0514	1,000		
	3-4	3	V2-S3.3X	FV2-S3.3X		3.2 (.126)	6.4 (.252)	16.1 (.634)	4.3 (.169)									
	3-4	3	V2-3X	FV2-3X		3.2 (.126)	8.5 (.335)	20.7 (.815)	7.8 (.307)									
	5-6	3.5	V2-S3X	FV2-S3X		3.7 (.146)	6.4 (.252)	15.9 (.626)	4.3 (.169)									
	5-6	3.5	V2-M3X	FV2-M3X		3.7 (.146)	6.6 (.260)	17.9 (.705)	6.3 (.248)									
	8	4	V2-M4X	FV2-M4X		4.3 (.169)	6.6 (.260)	17.7 (.697)	6.3 (.248)									
	8	4	V2-4X	FV2-4X		4.3 (.169)	8.5 (.335)	20.4 (.803)	7.8 (.307)									
	10	5	V2-M5X	FV2-M5X		5.3 (.209)	8.5 (.335)	20.1 (.791)	7.8 (.307)									
	10	5	V2-5X	FV2-5X		5.3 (.209)	9.5 (.374)	20.2 (.795)	7.3 (.287)									
	1/4	6	V2-6X	FV2-6X		6.4 (.252)	12.0 (.472)	25.0 (.984)	11.0 (.433)									
5/16	8	V2-8X	FV2-8X	8.4 (.331)	12.0 (.472)	24.3 (.957)	11.0 (.433)											
3/8	10	V2-10X	FV2-10X	10.5 (.413)	13.6 (.535)	27.2(1.071)	13.9 (.547)											
12 to 10 (2.63 to 6.64)	3-4	3	V5.5-3X	FV5.5-3X		3.2 (.126)	9.5 (.374)	26.2(1.031)	8.3 (.327)	13.5 (.531)	5.4 (.213)	6.8 (.268)	1.0 (.039)	Yellow	YNT-1210S YA-4 BCT-0514	1,000		
	5-6	3.5	V5.5-S3X	FV5.5-S3X		3.7 (.146)	7.2 (.283)	22.5 (.886)	5.9 (.232)									
	8	4	V5.5-S4X	FV5.5-S4X		4.3 (.169)	7.2 (.283)	22.3 (.878)	5.9 (.232)									
	8	4	V5.5-4X	FV5.5-4X		4.3 (.169)	9.5 (.374)	26.0(1.024)	8.3 (.327)									
	10	5	V5.5-5X	FV5.5-5X		5.3 (.209)	9.5 (.374)	25.7(1.012)	8.3 (.327)									
	10	5	V5.5-S5X	FV5.5-S5X		5.3 (.209)	13.2 (.520)	28.5(1.122)	9.0 (.354)									
	1/4	6	V5.5-6X	FV5.5-6X		6.4 (.252)	12.0 (.472)	31.5(1.240)	13.0 (.512)									
	1/4	6	V5.5-S6X	FV5.5-S6X		6.4 (.252)	13.2 (.520)	28.2(1.110)	9.0 (.354)									
	5/16	8	V5.5-S8X	FV5.5-S8X		8.4 (.331)	13.2 (.520)	27.6(1.087)	9.0 (.354)									
	5/16	8	V5.5-8X	FV5.5-8X		8.4 (.331)	15.0 (.591)	33.4(1.315)	13.7 (.539)									
3/8	10	V5.5-10X	FV5.5-10X	10.5 (.413)	15.0 (.591)	32.6(1.283)	13.7 (.539)											

- Note:1) The part numbers indicated in the above table are for products with a brazed seam.  
 When ordering products with a butted seam, add the prefix "WS" to the part number (ex. V2-5X → **VWS2-5X**).  
 2) To order products with nylon insulation, change the "V" in the part number prefix to "N" (ex. V2-4X → **N2-4X**).  
 Because nylon absorbs moisture, care must be taken concerning storage.  
 3) \*The crimping will be more secure if the total cross-sectional area of the wire is at least 0.5 mm<sup>2</sup>.  
 Examples: If the cross-sectional area of the wire is 0.3mm<sup>2</sup>, fold the wire in two when crimping the terminal.  
 If the cross-sectional area of the wire is 0.5mm<sup>2</sup>, crimp the terminal onto the wire as it is.  
 4) Delivery lead times may vary depending on the product. Contact JST for details.

Solderless terminals

**FORK TONGUE (Y type) Non-insulated**

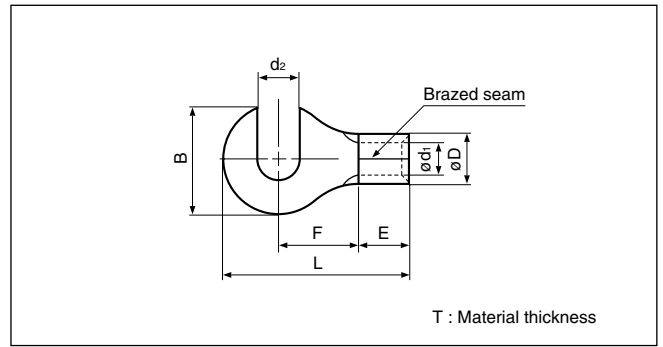
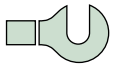

Certificate No.: E42024 LR20812

Applicable Wire AWG#(mm <sup>2</sup> )	Stud size		Part No.	Standard	Dimensions mm (in.)								Tool No.	Qty/box
	American	Metric			d <sub>2</sub>	B	L	F	E	ø D	ø d <sub>1</sub>	T		
22 to 16 (0.25 to 1.65)	1-2	2	1.25-2Y		2.2 (.087)	5.1 (.201)	11.5 (.453)	4.0 (.157)	4.8 (.189)	3.4 (.134)	1.7 (.067)	0.8 (.031)	YHT-2210 YA-1 YA-2 YA-4 BCT-0514	1,000
	3-4	3	1.25-3Y		3.2 (.126)	4.9 (.193)	11.5 (.453)	4.0 (.157)						
	3-4	3	1.25-L3Y		3.2 (.126)	7.7 (.303)	15.8 (.622)	7.0 (.276)						
	5-6	3.5	1.25-3.7Y		3.7 (.146)	4.8 (.189)	11.5 (.453)	4.0 (.157)						
	8	4	1.25-4Y		4.3 (.169)	7.4 (.291)	15.8 (.622)	7.0 (.276)						
	10	5	1.25-5Y		5.3 (.209)	7.0 (.276)	15.8 (.622)	7.0 (.276)						
	1/4	6	1.25-6Y		6.4 (.252)	10.6 (.417)	21.7 (.854)	11.1 (.437)						
	5/16	8	1.25-8Y		8.4 (.331)	9.7 (.382)	21.7 (.854)	11.1 (.437)						
16 to 14 (1.04 to 2.63)	1-2	2	2-S2Y		2.2 (.087)	6.2 (.244)	12.3 (.484)	4.3 (.169)	4.8 (.189)	4.1 (.161)	2.3 (.091)	0.8 (.031)	YHT-2210 YA-1 YA-2 YA-4 BCT-0514	1,000
	3-4	3	2-S3.3Y		3.2 (.126)	6.0 (.236)	12.3 (.484)	4.3 (.169)						
	5-6	3.5	2-S3Y		3.7 (.146)	5.8 (.228)	12.3 (.484)	4.3 (.169)						
	8	4	2-M4Y		4.3 (.169)	5.7 (.224)	14.4 (.567)	6.3 (.248)						
	8	4	2-4Y		4.3 (.169)	7.9 (.311)	16.8 (.661)	7.8 (.307)						
	10	5	2-M5Y		5.3 (.209)	8.4 (.331)	16.8 (.661)	7.3 (.287)						
	10	5	2-5Y		5.3 (.209)	8.7 (.343)	16.8 (.661)	7.8 (.307)						
	1/4	6	2-6Y		6.4 (.252)	11.0 (.433)	21.8 (.858)	11.0 (.433)						
5/16	8	2-8Y	8.4 (.331)	10.3 (.406)	21.8 (.858)	11.0 (.433)								
12 to 10 (2.63 to 6.64)	3-4	3	5.5-3Y		3.2 (.126)	9.2 (.362)	19.8 (.780)	8.3 (.327)	6.8 (.268)	5.6 (.220)	3.4 (.134)	1.0 (.039)	YHT-2210 YA-1 YA-2 YA-4 BCT-0514	500
	5-6	3.5	5.5-S3Y		3.7 (.146)	6.7 (.264)	15.7 (.618)	5.9 (.232)						
	8	4	5.5-S4Y		4.3 (.169)	6.5 (.256)	15.7 (.618)	5.9 (.232)						
	8	4	5.5-4Y		4.3 (.169)	9.1 (.358)	19.8 (.780)	8.3 (.327)						
	10	5	5.5-5Y		5.3 (.209)	8.7 (.343)	19.8 (.780)	8.3 (.327)						
	10	5	5.5-S5Y		5.3 (.209)	12.8 (.504)	22.4 (.882)	9.0 (.354)						
	1/4	6	5.5-6Y		6.4 (.252)	11.0 (.433)	25.8(1.016)	13.0 (.512)						
	1/4	6	5.5-S6Y		6.4 (.252)	12.3 (.484)	22.4 (.882)	9.0 (.354)						
	5/16	8	5.5-S8Y		8.4 (.331)	11.7 (.461)	22.4 (.882)	9.0 (.354)						
	5/16	8	5.5-8Y		8.4 (.331)	13.7 (.539)	28.0(1.102)	13.7 (.539)						
3/8	10	5.5-10Y	10.5 (.413)	12.9 (.508)	28.0(1.102)	13.7 (.539)								

Note:1) The part numbers indicated in the above table are for products with a brazed seam.

When ordering products with a butted seam, add the prefix "WS" to the part number (ex. 2-5Y → **WS2-5Y**).

2) Delivery lead times may vary depending on the product. Contact JST for details.