

SERIAL LINK INTERFACE

USER GUIDE

MODEL ILPH RS 422 - RS 485 / RS 422 - RS 485

Part/Number	Black body ENT	0084 231.17
	Grey body ABB V0	1SNA 684 231 R2500

1. GENERAL

Interface between an RS 232 serial link and an RS 422 ou RS 485 serial link. Extend transmission beyond the 15 m limit of the RS 232 serial link, to cross "noisy" environments, to perform multipointing (network) etc.

2. SCHEMATIC DIAGRAM

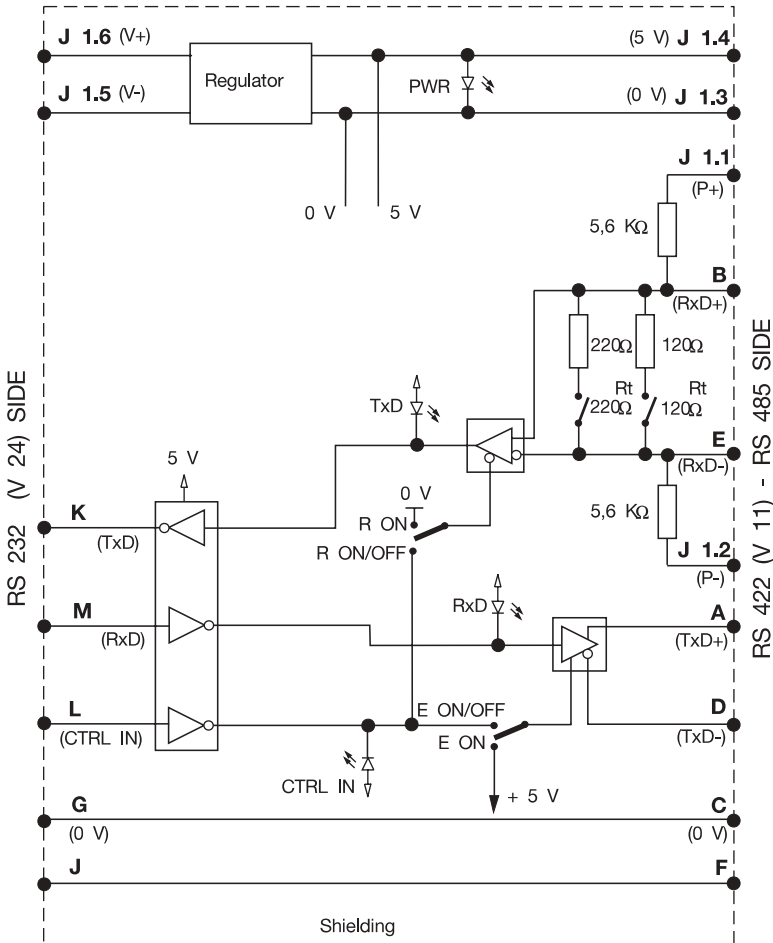

3. TECHNICAL SPECIFICATIONS

3.1 POWER SUPPLY

- Power supply voltage : 8,5 V to 28 VDC
- Protection : polarity inversion
- Power requirement : less than 100 mA
- 1 yellow "power on" Led.
- Screw-type plug-in connector.

3.2 RS 232 LINK

- EIA RS 232 C / CCITT V24 / V28
- I / O protection : over voltage
- Speed / Distance : 38400 Bauds / 15 m
- 3 green Leds (RxD, TxD, CTRL IN)
- Screw connection.

3.3 RS 422 - RS 485 LINK

- EIA RS 485 and compatible EIA RS 422 / CCITT V11
- I / O protection : over voltage
- Speed / Distance : 38400 Bauds / 1200m
- Transmitter can communicate with up to 32 receivers simultaneously.
- Screw connection.

3.4 PHYSICAL CHARACTERISTICS

- Box series 11000 ABB Entelec, snaps onto DIN rail
- Temperature :
 operation : 0 to 50° C
 storage : - 20 to 70° C

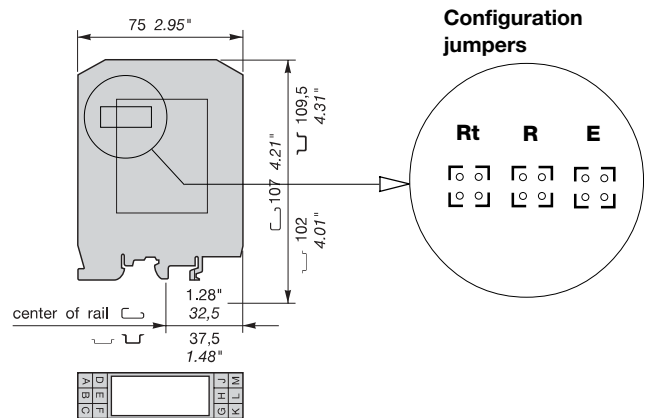



4. CONFIGURATION

4.1 LINE AMPLIFIER CONFIGURATION

Configuration of amplifiers of the RS 422 - RS 485 (Receiver, Transmitter) line provides greater flexibility of use. The various configurations can be selected using the 2 jumpers (R, E) located inside the box.

4.1.1 RS 485 LINK ON ONE PAIR



- R**  R ON/OFF Jumper R in position R ON/OFF
- E**  E ON/OFF Jumper E in position E ON/OFF

The Receiver and the Transmitter are activated alternately (never at the same time) depending on the status of the CTRL IN signal.

CTRL IN STATUS	ACTION ON RS 485
0 logic (+3V ≤ U ≤ +25V)	Transmitter active / Receiver inactive
1 logic (-25V ≤ U ≤ -3V)	Transmitter inactive / Receiver active
High impedance	Transmitter inactive / Receiver active



NOTE : For RS 232 products running the RTS (REQUEST TO SEND) signal, connect RTS to CTRL IN. Otherwise, connect M (RxD ILPH) to L (CTRL IN).

4.1.2 RS 485 LINK ON 2 PAIRS

- R**  R ON Jumper R in position R ON
- E**  E ON/OFF Jumper E in position E ON/OFF

Receiver permanently active
Transmitter controlled by the signal CTRL IN (see table 4.1.1 for Transmitter operation as a function of CTRL IN)

4.1.3 RS 422 LINK ON TWO PAIRS

- R**  R ON Jumper R in position R ON
- E**  E ON Jumper E in position E ON

The Transmitter and Receiver are both permanently active.

4.2 POLARIZATION OF THE RS 422 - RS 485 LINE



The line must always be polarized. The ILPH is used to polarize the reception channel :

- Connection by 1 wire P+ (J1.1) with 5V (J1.4)
Connection by 1 wire P- (J1.2) with 0V (J1.3)

4.3 ADAPTING THE RS 422 - RS 485 LINE

The line must always be adapted to the level of the reception channel of each subscriber forming the end of the bus.

The ILPH is used to adapt the reception channel by setting the jumper Rt correctly :

- Rt**  * Line adaptation, Rt = 120 Ω (general case)
- Rt**  * Line adaptation, Rt = 220 Ω
- Rt**  * No line adaptation, Rt = ∞

5. CONNECTIONS

RS 422 - RS 485 LINK ON 1 PAIR

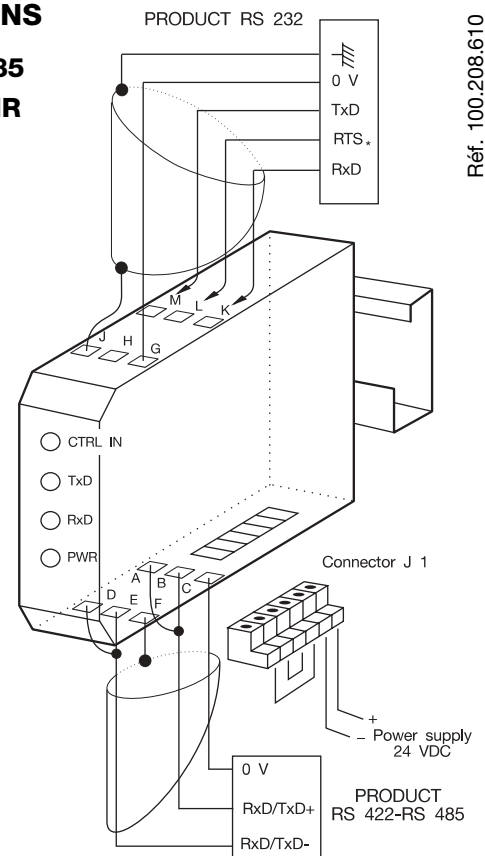

* NOTE : If the RTS signal is not generated, connect M (RxD ILPH) to L (CTRL IN).

RS 422 - RS 485 LINK ON 2 PAIRS

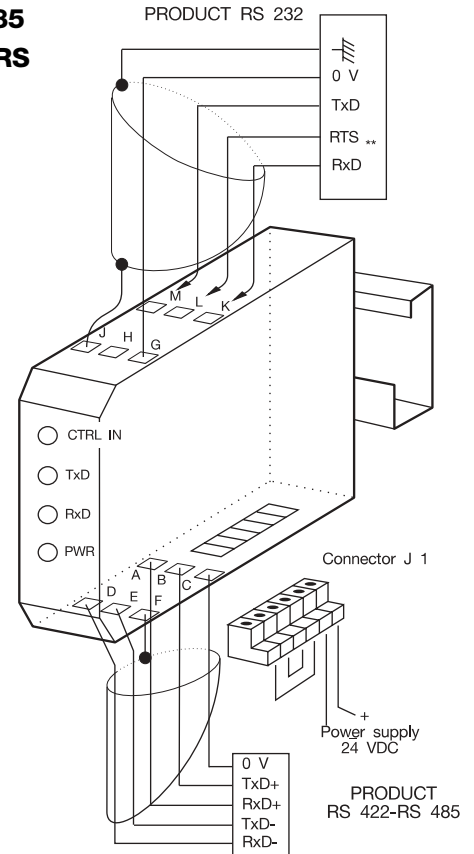

** NOTE : Only to be connected for RS 485 two pairs (of no use for RS 422 two pairs). If the RTS signal is not generated, connect M (RxD ILPH) to L (CTRL IN).