

**Ordering number C12446\_SOPHIE**

Family	Sophie	FWHM	Asym degrees
Type	Lens array	Efficiency	88 %
LED	Oslon SSL 150	cd/lm	0.600
Color	Clear	Gerber File	Available
Diameter	150 mm		
Height	10.43 mm		
Style	Rectang		
Optic Material	PMMA		
Holder Material	-		
Fastening	Glue		
Status	On production		

**NOTE: The typical divergence will be changed by different color, chip size and chip position tolerance. The typical total divergence is the full angle measured where the luminous intensity is half of the peak value.**



## PRODUCT DATASHEET

### Sophie series

last update 10/9/2013



#### GENERAL INFORMATION

- Product series especially designed & optimized for Oscon SSL 150 series of LEDs.
- Special care taken to make light distribution as uniform as possible.
- Lens material optical grade PMMA with high UV and temperature resistance. Allows use of high current and temperature conditions.

Please find more information about used material from below:

[http://ledil.fi/sites/default/files/Documents/Technical/Material/PMMA%20N%20UL94\\_Yellow%20Card.pdf](http://ledil.fi/sites/default/files/Documents/Technical/Material/PMMA%20N%20UL94_Yellow%20Card.pdf)

<http://ledil.fi/sites/default/files/Documents/Technical/Material/PMMA%20N%20PLEXIGLAS-Datasheet.pdf>

- Fastening to PCB with appropriate adhesive. By clicking link below you can find Ledil recommended glue options.

[http://www.ledil.com/datasheets/DataSheet\\_GLUES.pdf](http://www.ledil.com/datasheets/DataSheet_GLUES.pdf)

**NOTE 1: We advise customer to ensure the suitability and sufficiency of the bond in the end product. For example, mechanical stress, vibration and holes on the surface of the circuit board weaken the strength of the glue.**

**NOTE 2: All surfaces where glue is applied must be clean, dry and free from grease and dirt. If cleaning of PCB surfaces is needed, please follow strictly the cleaning instructions of your LED manufacturer -this is important as cleaning shall under no circumstances damage LEDs or other electronics components on the PCB.**

**Further note that optical components shall not be cleaned with any chemicals - only micro fiber cloth may be used to remove fingerprints or other traces from handling.**

D

C

B

A

4

4

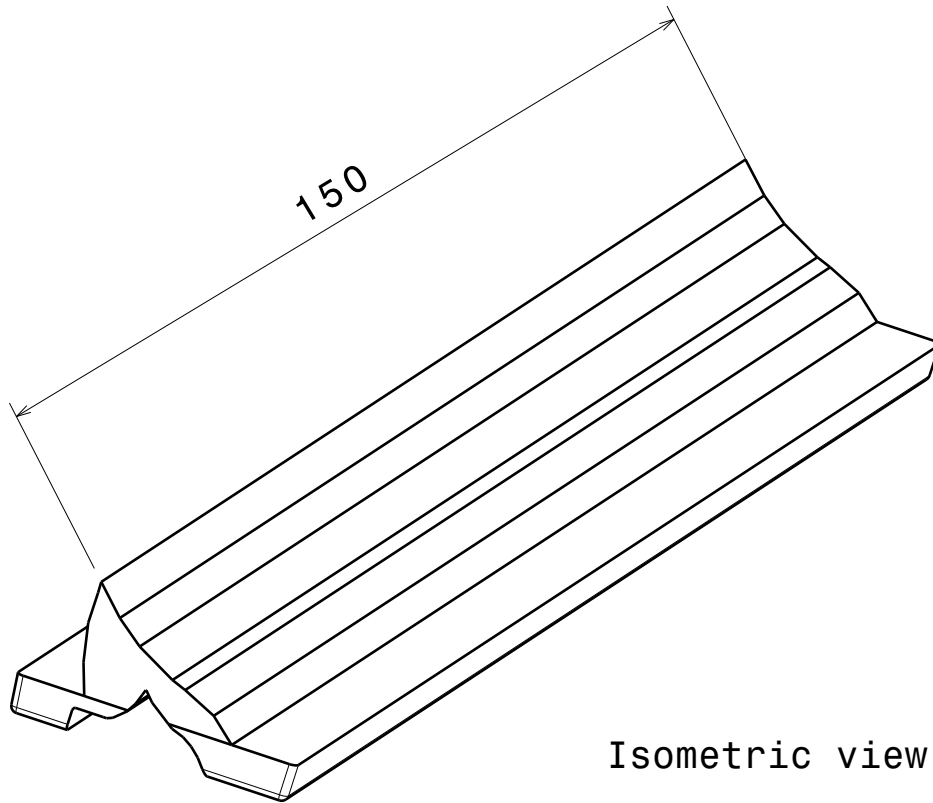

Isometric view

3

3

2

2

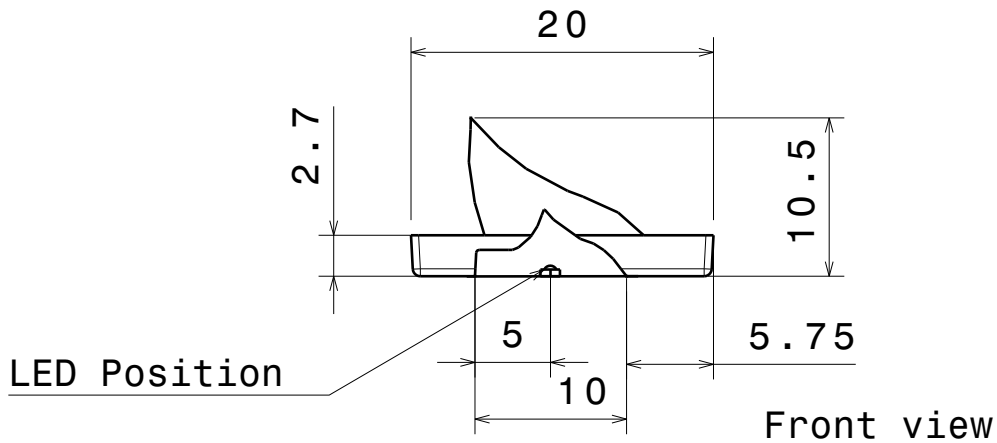

LED Position

Front view

MATERIAL: PMMA clear

Tolerances if not otherwise shown  
 According to DIN ISO 2768-1  
 Linear measures:  
 Up to 30mm class F, otherwise class M.  
 According to DIN ISO 2768-2  
 Form and position: class K

**LEDiL** Ledil Oy  
 Salorankatu 10  
 FIN 24240 SALO  
 Finland

THIRD ANGLE PROJECTION:

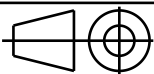

DRAWING TITLE

C12446\_Sophie

This drawing is the property  
 of LEDiL Oy. It may not be  
 reproduced, copied or  
 communicated without a written  
 agreement with LEDiL Oy."

SIZE PART NUMBER

A4

Datasheet

SCALE

1:1

WEIGHT

(g)

SHEET

1/1

D

A

1

1

# LEDiL Oy C12446\_SOPHIE\_(SSL150) Eff.88.4% / LDC (Linear)

Luminaire: LEDiL Oy C12446\_SOPHIE\_(SSL150) Eff.88.4%  
Lamps: 1 x Oslon\_SSL150\_6x1 (600.175lm@250mA)

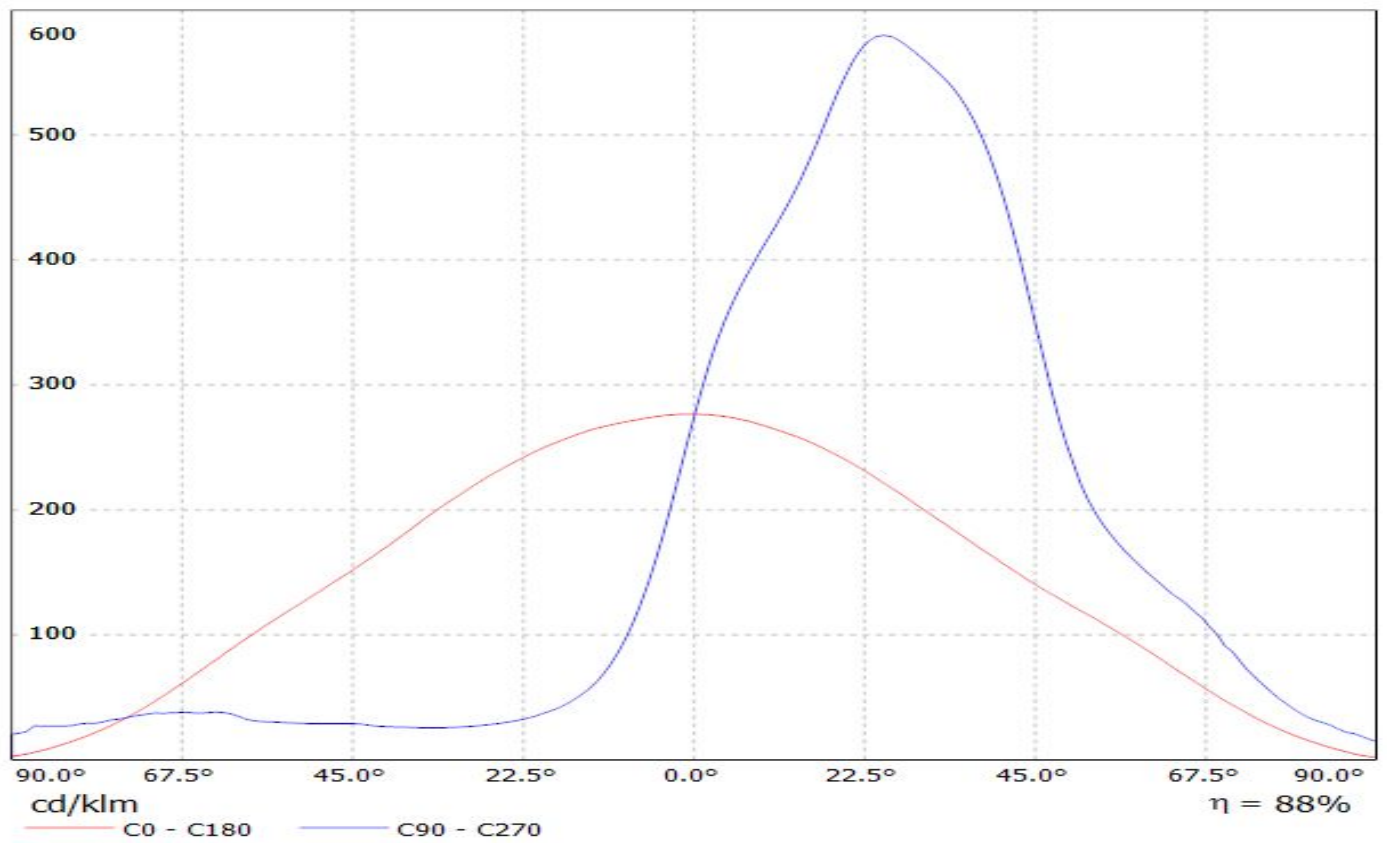

# LEDiL Oy C12446\_SOPHIE\_(SSL150) Eff.88.4% / LDC (Polar)

Luminaire: LEDiL Oy C12446\_SOPHIE\_(SSL150) Eff.88.4%  
Lamps: 1 x Oslon\_SSL150\_6x1 (600.175lm@250mA)

