

F²MC-16LX FAMILY EVALUATION BOARD FLASH-CAN-100P-340

USER GUIDE

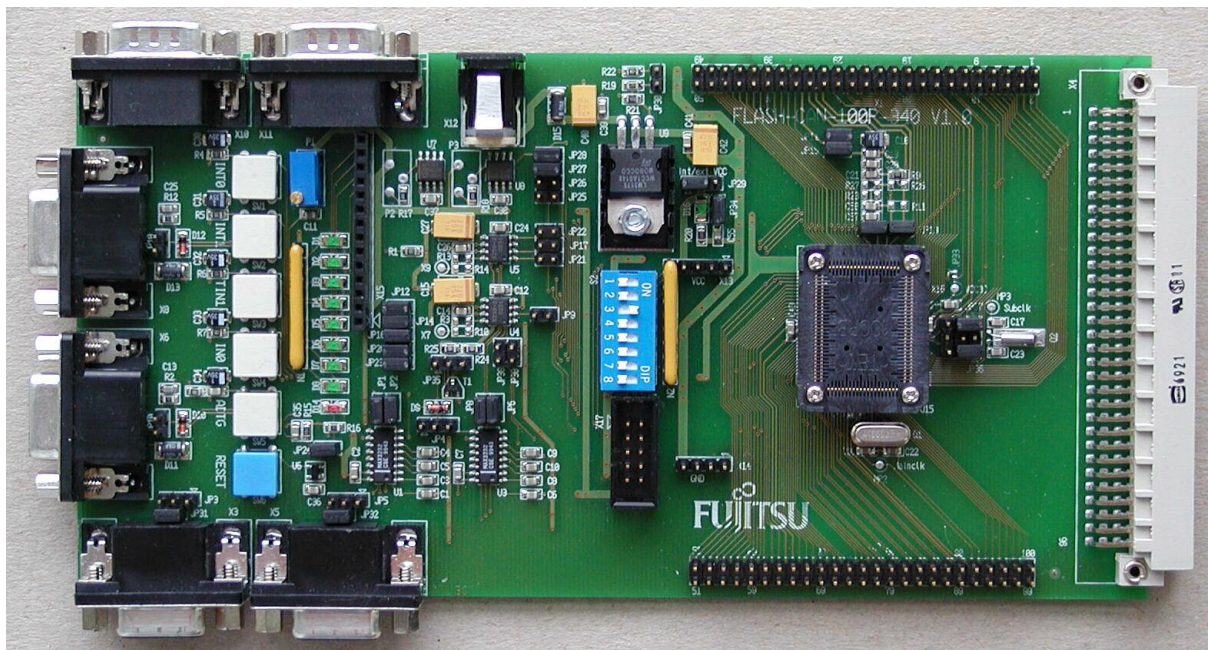

Revision History

Date	Issue
05.02.2003	V1.0,HW, First Release
07/02/2003	V1.1, MST, Disclaimer corrected

This document contains 27 pages.

Warranty and Disclaimer

To the maximum extent permitted by applicable law, Fujitsu Microelectronics Europe GmbH restricts its warranties and its liability for **the FLASH-CAN-100P-340 Board and all its deliverables** (eg. software include or header files, application examples, target boards, evaluation boards, engineering samples of IC's etc.), its performance and any consequential damages, on the use of the Product in accordance with (i) the terms of the License Agreement and the Sale and Purchase Agreement under which agreements the Product has been delivered, (ii) the technical descriptions and (iii) all accompanying written materials. In addition, to the maximum extent permitted by applicable law, Fujitsu Microelectronics Europe GmbH disclaims all warranties and liabilities for the performance of the Product and any consequential damages in cases of unauthorised decompiling and/or reverse engineering and/or disassembling. **Note, the FLASH-CAN-100P-340 Board and all its deliverables are intended and must only be used in an evaluation laboratory environment .**

1. Fujitsu Microelectronics Europe GmbH warrants that the Product will perform substantially in accordance with the accompanying written materials for a period of 90 days from the date of receipt by the customer. Concerning the hardware components of the Product, Fujitsu Microelectronics Europe GmbH warrants that the Product will be free from defects in material and workmanship under use and service as specified in the accompanying written materials for a duration of 1 year from the date of receipt by the customer.
2. Should a Product turn out to be defect, Fujitsu Microelectronics Europe GmbH's entire liability and the customer's exclusive remedy shall be, at Fujitsu Microelectronics Europe GmbH's sole discretion, either return of the purchase price and the license fee, or replacement of the Product or parts thereof, if the Product is returned to Fujitsu Microelectronics Europe GmbH in original packing and without further defects resulting from the customer's use or the transport. However, this warranty is excluded if the defect has resulted from an accident not attributable to Fujitsu Microelectronics Europe GmbH, or abuse or misapplication attributable to the customer or any other third party not relating to Fujitsu Microelectronics Europe GmbH.
3. To the maximum extent permitted by applicable law Fujitsu Microelectronics Europe GmbH disclaims all other warranties, whether expressed or implied, in particular, but not limited to, warranties of merchantability and fitness for a particular purpose for which the Product is not designated.
4. To the maximum extent permitted by applicable law, Fujitsu Microelectronics Europe GmbH's and its supplier's liability are restricted to intention and gross negligence.

NO LIABILITY FOR CONSEQUENTIAL DAMAGES

To the maximum extent permitted by applicable law, in no event shall Fujitsu Microelectronics Europe GmbH and its suppliers be liable for any damages whatsoever (including but without limitation, consequential and/or indirect damages for personal injury, assets of substantial value, loss of profits, interruption of business operation, loss of information, or any other monetary or pecuniary loss) arising from the use of the Product.

Should one of the above stipulations be or become invalid and/or unenforceable, the remaining stipulations shall stay in full effect

0 Contents

REVISION HISTORY	2
WARRANTY AND DISCLAIMER.....	3
0 CONTENTS.....	4
1 OVERVIEW	5
1.1 Abstract	5
1.2 Features	5
1.3 General Description	6
2 INSTALLATION	7
3 JUMPERS AND SWITCHES	8
3.1 Jumper Overview.....	8
3.2 Operating-Mode (S2).....	10
3.3 Power Supply Voltage (JP: 29, 34)	11
3.4 Analogue Power Supply Voltage (JP: 11, 13, 15)	12
3.5 Subclock (JP: 36,37).....	13
3.6 UART"A" (JP: 1, 2, 31).....	14
3.7 UART"B" (JP: 6, 8, 32).....	14
3.8 LIN"A" (JP: 17, 18, 21, 22).....	15
3.9 LIN"B" (JP: 9, 10, 38, 39).....	15
3.10 CAN"A" (JP: 25, 26).....	16
3.11 CAN"B" (JP: 27, 28).....	16
3.12 Reset-Generation (JP: 3, 4, 5, 24, 35)	17
3.13 Buttons INT0, INT1, TIN1, IN0, ADTG, Reset (JP: 12, 14, 16, 20, 23, 24)	18
4 PROGRAMMING THE INTERNAL FLASH.....	19
4.1 Asynchronous Mode	19
4.2 Synchronous Mode.....	21
5 CONNECTORS	22
5.1 Power connector (X12)	22
5.2 Edge connector (X1, X2)	22
5.3 UART"A", UART"B" connector (X3, X5)	22
5.4 LIN"A", LIN"B" Interface connector (X6, X8).....	23
5.5 CAN"A", CAN"B" Interface connector (X10, X11)	23
5.6 USER-LEDs & LC-Display (optional)	23
5.7 VG96 connector (X4)	24
6 SILK-PLOT OF THE BOARD.....	25
7 RELATED PRODUCTS.....	26
8 INFORMATION IN THE WWW.....	27

1 Overview

1.1 Abstract

The FLASH-CAN-100P-340 is a multifunctional evaluation board for the Fujitsu 16-Bit Flash microcontroller MB90340series and MB90860series.

It can be used stand alone for software development and testing or as a simple target board to work with the emulator system.

The board allows the designer immediately to start with the software development before his own final target system is available.

1.2 Features

- ▶ Supports MB90340series and MB90860series in FPT-100P-M06 package
 - ▶ MB90340series: MB90V340, MB90F347
 - ▶ MB90860series: MB90V340, MB90F867 (MB90860series does not support CAN)
- ▶ 9-12V unregulated external DC power supply usable
- ▶ 5V internal power supply, Power-LED
- ▶ In-Circuit serial Flash programming
- ▶ All resources available for evaluation
- ▶ All pins routed to connectors
- ▶ 4 MHz main-crystal, 32kHz subclock-crystal (selectable by jumpers)
- ▶ Two UART Interfaces
- ▶ Two LIN-Transceivers
- ▶ Two High-Speed CAN Transceivers
- ▶ 8 User LEDs, optional: alphanumeric standard LC-Display connectable instead of LEDs
- ▶ Reset-Button, Reset-LED
- ▶ 5 User-buttons configurable for INT0, INT1, TIN1, IN0 and ADTG/TIN0
- ▶ 96pin VG connector

The target board will be delivered with the MB90F347 microcontroller.

This microcontroller contains a 'burn-in'-boot loader for programming the flash.

**This board must only be used for test applications
in an evaluation laboratory environment.**

1.3 General Description

The FLASH-CAN-100P-340 supports 16-Bit Flash microcontrollers of the MB90340series as well as the CAN-less MB90860series.

It can be used as a stand alone evaluation board or as a target board for emulator debugger.

The evaluation board supports the following package: FPT-100P-M06

The board is supplied with a socketed 4MHz crystal as the main oscillation clock. Using the internal PLL of the μ C, internal clock rates up to 24MHz can be achieved.

Additionally a 32kHz crystal is mounted for use as a subclock, if this is supported by the device type.

Two separate RS232 transceivers are available to connect the on-chip UART0 and UART2 to 9-pin D-Sub connectors (X3, X5). The transceivers generate the adequate RS232 levels for the receive (RXD) and transmit (TXD) lines. Either the DTR line or the CTS line can be selected with jumpers (JP3, JP4, JP5) to generate a system reset. The RTS signal can be shortcut to CTS using the jumpers JP31 and JP32.

In-circuit-programming (asynchronous) can be done via UART0 (UART"A", X3) using the Burn-In Bootloader of the microcontroller.

Two single-wire LIN-transceivers (TLE6259) are available to connect the on-chip UART1 and UART3 to 9-pin D-Sub connectors (X6, X8). The transceivers generate the adequate levels to drive the bus line in LIN-systems for automotive and industrial applications.

Two high-speed CAN-transceivers (PCA82C250) are available to connect the on-chip CAN-controller to 9-pin D-Sub connectors (X10, X11). The transceivers provides differential transmit and receive capability between CAN-controller and CAN-bus.

If the board is used as an emulator target board, the microcontroller must be removed from the socket and the corresponding probe cable has to be used:

Probe Cable: **MB2147-582**

Header Socket: **NQPack100rb + HQPack100rb179-V2**

All pins of the microcontroller are connected to the edge connectors X1 and X2 and are directly available to the user. Furthermore, the most important signals are available on the VG96 connector (X4).

The on-board voltage regulator allows the user to connect an unregulated DC input voltage between +9V to +12V. In case of any modifications of the board, care should be taken that the total power consumption will not damage the regulator.

There are six push button switches on the board, used for Reset, External Interrupts INTO and INT1, Trigger for Reload-Timer1 (TIN1), Input-Capture (IN0) and Trigger for the A/D-converter (ADTG) or for Reload-Timer0 (TIN0).

Eight user-LEDs are connected via a 1K pull up resistor network to Port P00-P07. If these LEDs are not required, than the resistor network can be removed to disconnect the LEDs and to free the port. Take care of Port P00 and P01, which needs the 1k Resistor while serial in-circuit programming!

The operating mode of the microcontroller can be selected by the Dip-switch S2.

2 Installation

Remove carefully the board from the shipping carton.

Check first if there are any damages before power on the evaluation board.

For the power supply a DC input voltage of 9V – 12V is recommended. The positive voltage (+) must be connected to the shield, and ground (GND) must be connected to the centre of the connector X12!

After power-on, the green power-on LED (D16) should be on. If the LED does not light switch off the power supply and check the default jumper settings.

By default, the evaluation board is equipped with a MB90F347 and the device has been programmed with a test program. So after power-on a running light for the eight user LEDs can be seen. Furthermore, a welcome string is output with 9600 baud on both UART channels (UART"A" / UART"B"). Please use 1:1 cable for the PC-connection.

The in-circuit programming allows the user to program it's own application into the Flash-memory. How to program the Flash memory is described in chapter 4.

If the board is used as an emulator target board, switch off the power supply and remove the microcontroller from the socket. Now the probe cable can be mounted into the socket. Take care of pin 1 marking onto the socket and fix the probe cable with screws.

Do not use other probe cable than MB2147-582 only!

Connect the probe cable to the emulation pod. Check all DIP-switch-settings of the evaluation board and the emulation pod.

For the power on sequence the emulator system must be switched on first, after that, switch on the evaluation board. Please look at the corresponding user manuals for the emulator how to set up the emulator system. After the power on the 'Reset'-LED of the emulator must be off and the 'Vcc'-LED must be on.

If the Reset LED is still lighting, check the DIP-switch-settings of the emulator system and the power supply of the evaluation board.

3 Jumpers and Switches

This chapter describes all jumpers and switches which can be modified on the evaluation board. The default setting is shown with a grey shaded area. All jumpers and switches are named directly on the board, so it is very easy to set the jumpers according to the features.

3.1 Jumper Overview

Jumper	Description / Function	Type	Default	Coordinates
JP1	UART A (TXD)	Jumper 2 pol	closed	HJ 21
JP2	UART A (RXD)	Jumper 2 pol	closed	HJ 21
JP3	DTR/RTS A	Jumper 3 pol	open	K 26
JP4	RESET UART A/B	Jumper 3 pol	open	J 19/20
JP5	DTR/RTS B	Jumper 3 pol	open	K 22
JP6	UART B (RXD)	Jumper 2 pol	closed	HJ 18
JP8	UART B (TXD)	Jumper 2 pol	closed	HJ 18
JP9	LIN B enable	Jumper 2 pol	open	G 17
JP10	Master-Mode B	Jumper 2 pol	open	J 27
JP11	AVcc	Jumper 2 pol	closed	D 9/10
JP12	SW INT0	Jumper 2 pol	closed	G 21
JP13	AVcc=AVRH	Jumper 2 pol	closed	E 8
JP14	SW INT1	Jumper 2 pol	closed	G 21
JP15	AVss	Jumper 2 pol	closed	D 9/10
JP16	SW TIN1	Jumper 2 pol	closed	GH 21
JP17	LIN A enable	Jumper 2 pol	open	F 17
JP18	Master-Mode A	Jumper 2 pol	open	F 27
JP19	AVss=AVRL	Jumper 2 pol	closed	E9
JP20	SW IN0	Jumper 2 pol	closed	H 21
JP21	LIN A (RXD)	Jumper 2 pol	open	F 17
JP22	LIN A (TXD)	Jumper 2 pol	open	E 17
JP23	SW ADTG	Jumper 2 pol	closed	H 21
JP24	RESET	Jumper 2 pol	closed	J 23
JP25	CAN A (TXD)	Jumper 2 pol	closed	E 17
JP26	CAN A (RXD)	Jumper 2 pol	closed	E 17
JP27	CAN B (TXD)	Jumper 2 pol	open	D 17
JP28	CAN B (RXD)	Jumper 2 pol	open	D 17
JP29	int/ext VCC	Jumper 3 pol	1-2	D 13
JP30	5V/3V3	Jumper 2 pol	open	C 14
JP31	RTS-CTS A	Jumper 2 pol	closed	K 26
JP32	RTS-CTS B	Jumper 2 pol	closed	K 22
JP33	C-Pin	sold-Jumper	open	F 6
JP34	MCU_VCC	Jumper 2pol	closed	E 12
JP35	Reset inverter	Jumper 3 pol	open	H 19
JP36	X0A select	Jumper 3 pol	1-4	G 6
JP37	X1A select	Jumper 3 pol	1-2	G 6
JP38	LIN B (RXD)	Jumper 2 pol	open	G 18
JP39	LIN B (TXD)	Jumper 2 pol	open	G 18

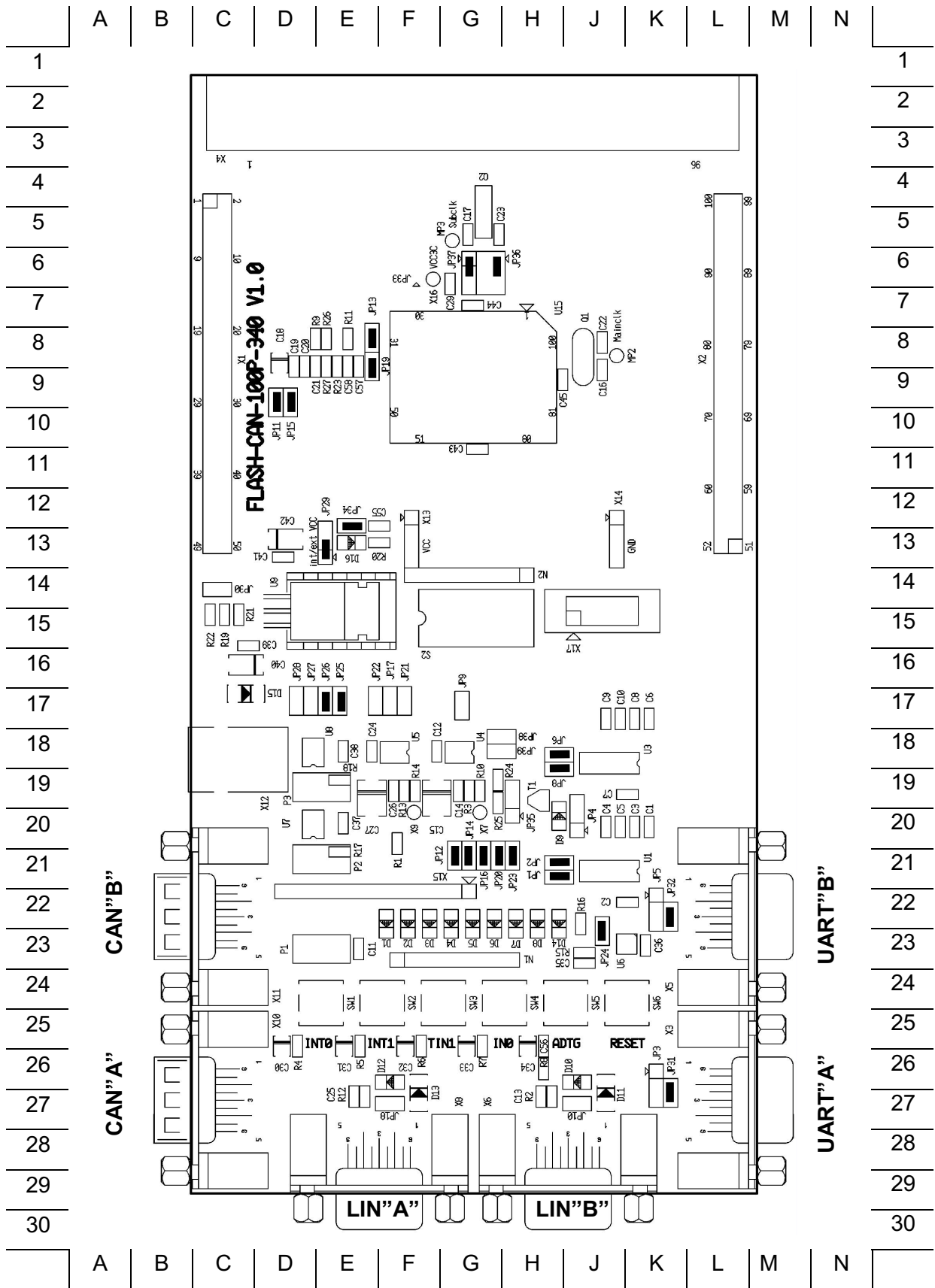

3.2 Operating-Mode (S2)

The DIP-switch S2 is used to set the operating mode of the μ C.

Ensure that the mode pin settings correspond to the operation-mode of the application.

For more detailed information please check the Hardware-Manual of the microcontroller.

DIP switch	Setting	Logical value
S2/1 (MD0)	ON (closed)	0 (low)
	OFF (open)	1 (high)
S2/2 (MD1)	ON (closed)	0 (low)
	OFF (open)	1 (high)
S2/3 (MD2)	ON (closed)	0 (low)
	OFF (open)	1 (high)
S2/4	not connected (OFF)	
S2/5	not connected (OFF)	
S2/6	not connected (OFF)	
S2/7 (P01)	ON (closed)	1 (high)
	OFF (open)	0 (low) ^{*1}
S2/8 (P00)	ON (closed)	1 (high)
	OFF (open)	0 (low) ^{*1}

Default: MD0, 1, 2 = 1 1 0 P00, P01 = 0 0

By default, the Single Chip Run-Mode is selected.

Note: ^{*1} Take care that the low-level is reached by the resistor-network N1 and the LEDs D1/D2. In case that N1 is removed in order to free the Port, then P00 and P01 have to be connected manually to GND in case of asynchronous programming (see chapter 4).

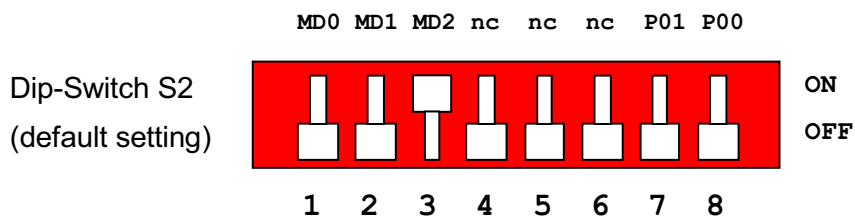

3.3 Power Supply Voltage (JP: 29, 34)

Vcc and GND (Vss) are both connected to the edge-connector (X4) in order to supply additional circuitry. However, if the current requirements exceed the maximum ratings of the on board voltage regulator LM317T, the board also can be powered externally via the edge-connector. In that case, take care of the input-voltage. Neither a voltage regulation nor an over-voltage-protection does exist for an external power-supply.

JP29 Power Supply selection

In case that the board is powered via the VG-connector (X4), a regulated 5V power source has to be used.

JP34 This Jumper is used to connect the Vcc supply voltage to the μC . Connecting an Ampere-meter allows measuring of the power-supply-current of the microcontroller (Icc).

Jumper	Setting	Description
JP29 (Vcc)	1 - 2	On-board voltage regulation
	2 - 3	External power-supply from X4 pin 1
JP34 (MCUVcc)	ON (closed)	Power supply Vcc connected to μC
	OFF (open)	Disconnected from Power supply Vcc

Default: JP29 = 1-2, JP34 = ON,

By default, the on-board Voltage regulation is used and the microcontroller is powered.

3.4 Analogue Power Supply Voltage (JP: 11, 13, 15)

The power supply as well as the positive reference voltage for the A/D-converter can be provided internally or externally.

JP11, JP15 connect power supply voltages (AVcc and AVss)

JP13, JP19 connect reference voltages (AVRH to AVcc, AVRL to AVss)

Jumper	Setting	Description
JP11 (AVcc)	ON (closed)	AVcc is connected to Vcc
	OFF (open)	AVcc is disconnected from Vcc
JP13 (AVRH)	ON (closed)	AVRH is connected to AVcc
	OFF (open)	AVRH defined by resistor network ^{*1}
JP15 (AVss)	ON (closed)	AVss is connected to GND
	OFF (open)	AVss is disconnected from GND
JP19 (AVRL)	ON (closed)	AVRL is connected to AVss
	OFF (open)	AVRL defined by resistor network ^{*1}

^{*1}By default the resistor network (R11, R23 and R26, R27) is not mounted on the board

Default: JP11, JP13, JP15 and JP19 are closed

By default, the A/D-converter supply and reference voltage is +5V.

Note:

If JP11 and JP15 are open, the user has to supply an adequate analogue voltage supply (AVcc and AVss) to the A/D-converter.

If JP13 is open, the resistors R11 and R23 define AVRH.

If JP19 is open, the resistors R26 and R27 define AVRL.

By default the resistor network (R11, R23 and R26, R27) is not mounted on the board.

3.5 Subclock (JP: 36,37)

Some devices like e.g. MB90F347 support a 32kHz subclock (X0A, X1A), other devices like MB90FxxxS do not support a subclock but will offer additional port-pins (P40, P41) instead.

Please check the related datasheet.

JP36: defines usage of Pin 13 (X0A/P40)

Pin-out JP36:

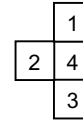

JP37: defines usage of Pin 14 (X1A/P41)

Jumper	Setting	Description
JP36 (X0A/P40)	1-4	Pin 13 is connected to the 32kHz Subclock (X0A)
	2-4	Pin 13 is used as P40 and is connected to X4-A16
	3-4	Pin 13 is connected to GND (in case that subclock-device is used, but no 32kHz crystal is connected)
JP37 (X1A/P41)	1-2	Pin 14 is connected to the 32kHz Subclock (X1A)
	2-3	Pin 14 is used as P41 and is connected to X4-A17

Default: JP36: 1-4, JP37: 1-2

By default, the 32kHz-subclock-crystal is connected to the microcontroller.

3.6 UART"A" (JP: 1, 2, 31)

One RS232-transceiver can be connected to UART0.

JP1, JP2 connects UART0 to the RS232-transceiver (U1, X3)

JP31 Some Flash-programming-Tools needs a connection between CTS and RTS

Jumper	Setting	Description
JP1 (UART"A"TxD)	ON (closed)	SOT0 is connected to RS232-Transceiver
	OFF (open)	SOT0 is disconnected from RS232-Transceiver
JP2 (UART"A"RxD)	ON (closed)	SIN0 is connected to RS232-Transceiver
	OFF (open)	SIN0 is disconnected from RS232-Transceiver
JP31 (RTS-CTS)	ON (closed)	RTS and CTS is shortcut on X3
	OFF (open)	RTS and CTS is not shortcut on X3

Default: JP1=ON, JP2=ON, JP31 = ON

By default, UART0 is used as UART"A".

3.7 UART"B" (JP: 6, 8, 32)

One RS232-transceiver can be connected to UART2.

JP6, JP8 connects UART2 to the RS232-transceiver (U3, X5)

JP32 Some Flash-programming-Tools needs a connection between CTS and RTS

Jumper	Setting	Description
JP6 (UART"B"RxD)	ON (closed)	SIN2 is connected to RS232-Transceiver
	OFF (open)	SIN2 is disconnected from RS232-Transceiver
JP8 (UART"B"TxD)	ON (closed)	SOT2 is connected to RS232-Transceiver
	OFF (open)	SOT2 is disconnected from RS232-Transceiver
JP31 (RTS-CTS)	ON (closed)	RTS and CTS is shortcut on X5
	OFF (open)	RTS and CTS is not shortcut on X5

Default: JP6=ON, JP8=ON, JP32 = ON

By default, UART2 is used as UART"B".

3.8 LIN"A" (JP: 17, 18, 21, 22)

One LIN-transceiver be used with UART1.

JP17 enable LIN-Transceiver

JP18 LIN Master-mode

JP21, JP22 connects UART1 to the LIN-transceiver (U5, X8)

Jumper	Setting	Description
JP17 (LIN enable)	open	LIN-transceiver is disabled
	closed	LIN-transceiver is enabled
JP18 (LIN Master)	open	LIN Slave-mode
	closed	LIN Master-mode
JP21 (LIN"A"RXD)	open	SIN1 is disconnected from LIN-Transceiver
	closed	SIN1 is connected to LIN-Transceiver
JP22 (LIN"A"TXD)	open	SOT1 is disconnected from LIN-Transceiver
	closed	SOT1 is connected to LIN-Transceiver

Default: JP17, JP18, JP21, JP22 = open

By default, UART1 is not used as LIN-interface.

3.9 LIN"B" (JP: 9, 10, 38, 39)

One LIN-transceiver can be used with UART3.

JP9 enable LIN-Transceiver

JP10 LIN Master-mode

JP38, JP39 connects UART3 to the LIN-transceiver (U4, X6)

Jumper	Setting	Description
JP9 (LIN enable)	open	LIN-transceiver is disabled
	closed	LIN-transceiver is enabled
JP10 (LIN Master)	open	LIN Slave-mode
	closed	LIN Master-mode
JP38 (LIN"B"RXD)	open	SIN3 is disconnected from LIN-Transceiver
	closed	SIN3 is connected to LIN-Transceiver
JP39 (LIN"B"TXD)	open	SOT3 is disconnected from LIN-Transceiver
	closed	SOT3 is connected to LIN-Transceiver

Default: JP9, JP10, JP38, JP39 = open

By default, UART3 is not used as LIN-interface.

3.10 CAN“A” (JP: 25, 26)

One high-speed CAN-transceivers can be connected to CAN0.

JP25, JP26 connects the CAN0-Port to the CAN-transceiver (U7, X10).
If the CAN interface is not used, the jumpers should be left open.

Jumper	Setting	Description
JP25 (TX0)	Open	TX0 is disconnected from CAN-Transceiver (U7, X10)
	Closed	TX0 is connected to CAN-Transceiver (U7, X10)
JP26 (RX0)	Open	RX0 is disconnected from CAN-Transceiver (U7, X10)
	Closed	RX0 is connected to CAN-Transceiver (U7, X10)

Default: JP25, JP26 = Closed

By default, the CAN“A”-transceiver is connected to CAN0 of the microcontroller

3.11 CAN“B” (JP: 27, 28)

One high-speed CAN-transceivers can be connected to CAN1.

JP27, JP28 connects the CAN1-Port to the CAN-transceiver (U8, X11).
If the CAN interface is not used, the jumpers should be left open.

Jumper	Setting	Description
JP27 (TX1)	Open	TX1 is disconnected from CAN-Transceiver (U8, X11)
	Closed	TX1 is connected to CAN-Transceiver (U8, X11)
JP28 (RX1)	Open	RX1 is disconnected from CAN-Transceiver (U8, X11)
	Closed	RX1 is connected to CAN-Transceiver (U8, X11)

Default: JP27, JP28 = Open

By default, the CAN“B”-transceiver is not connected to CAN1 of the microcontroller, because MB90F347 does not support CAN1.

3.12 Reset-Generation (JP: 3, 4, 5, 24, 35)

Additional to the internal Power-On-Reset the microcontroller can be reset by an external Reset-circuit (Voltage-Monitor) and by the UARTs, too.

JP3, JP5 As well the DTR-line as the RTS-Line of UART"A" or UART"B" can be used to generate a system-reset.

JP4 This jumper selects whether the DTR/RTS line from UART"A" or UART"B" will generate a system-reset.

JP24 open this jumper if no external Reset shall be generated.
In this case only the internal reset is active (e.g.: power-on)

JP35 The polarity of the DTR/RTS line can be invert by this jumper.
Remove the jumper in order to disable the reset logic.

Jumper	Setting	Description
JP3 (DTR / RTS "A")	1-2	DTR of UART"A" is selected
	2-3	RTS of UART"A" is selected
JP4 (UART"A"/"B")	1-2	UART"A" is used to generate Reset
	2-3	UART"B" is used to generate Reset
JP5 (DTR / RTS "B")	1-2	DTR of UART"B" is selected
	2-3	RTS of UART"B" is selected
JP24 (Main Reset)	closed	external Reset generation is active
	open	no external Reset generation
JP35 (Polarity)	1-2	No polarity inversion for the DTR/RTS signal
	2-3	Polarity inversion for the DTR/RTS signal

Default: JP24 = closed, JP4, JP5 and JP35 are not set

By default, the external Reset generation is active. The Reset by UART is disabled.

Note:

While a reset signal is asserted the red Reset-LED D14 is lit.

During normal operation, this LED should be off!

If JP35 (Polarity) is set, than JP4 and JP5 have to be set, too.

If the reset LED is steadily on, check the power supply input voltage and the settings for the reset-generation by UART.

3.13 Buttons INT0, INT1, TIN1, IN0, ADTG, Reset (JP: 12, 14, 16, 20, 23, 24)

JP12, JP14: Two push buttons can be used to trigger the external interrupts INT0 and INT1

JP16: One button can be used as trigger-input for the Reload-Timer1 (TIN1)

JP20: One Button can be used for input at Input-Capture0 (IN0)

JP23: One Button can be used as trigger for the A/D-converter (ADTG) or as trigger-input for the Reload-Timer0 (TIN0)

JP24: One Button can be used for manually reset

Jumper	Setting	Description
JP12 (INT0)	Closed	INT0 is connected to Push-button "INT0"
	Open	no connection to INT0
JP14 (INT0)	Closed	INT1 is connected to Push-button "INT1"
	Open	no connection to INT0
JP16 (TIN1)	Closed	TIN1 is connected to Push-button "TIN1"
	Open	no connection to TIN1
JP20 (IN0)	Closed	IN0 is connected to Push-button "IN0"
	Open	no connection to IN0
JP23 (ADTG) (TIN0)	Closed	ADTG/TIN0 is connected to Push-button "ADTG/TIN0"
	Open	no connection to ADTG/TIN0
JP24 (Reset)	Closed	RSTX is connected to Push-button "Reset"
	Open	no connection to RSTX

Default: JP12, JP14, JP16, JP20, JP23, JP24 = Closed

By default, INT0, INT1, TIN1, IN0, ADTG/TIN0 and RSTX of the microcontroller are connected to the Push buttons.

4 Programming the internal Flash

All Flash devices have an internal bootloader for asynchronous- as well as synchronous-Flash-programming:

- ▶ asynchronous-serial Flash-programming via UART0 (X3)
- ▶ synchronous-serial Flash-programming via Serial I/O (SCI0, X17)

4.1 Asynchronous Mode

In order to program the Flash-ROM asynchronously via UART0, the tool “Fujitsu Flash MCU Programmer for FMC16LX” can be used. This tool is available free on the Fujitsu Micros CD-ROM or Web Site (<http://www.fme.gsdc.de/gsd.htm>: select ▶ Software ▶ Utilities)

The following procedure must be followed to enable Flash Programming:

1. Power off the board
2. Connect the Evaluation Board UART”A” to your serial PC communication port. A straight cable connection has to be used.
3. Check the Jumper-settings according to the UART as described in chapter 3.5
4. Configure the mode:



5. Power on the board
6. Check that the Reset LED is off. Otherwise change the DTR polarity (JP35) and check the power supply voltage.
7. Start the tool “Fujitsu Flash MCU Programmer for FMC16LX” software and follow the instructions:

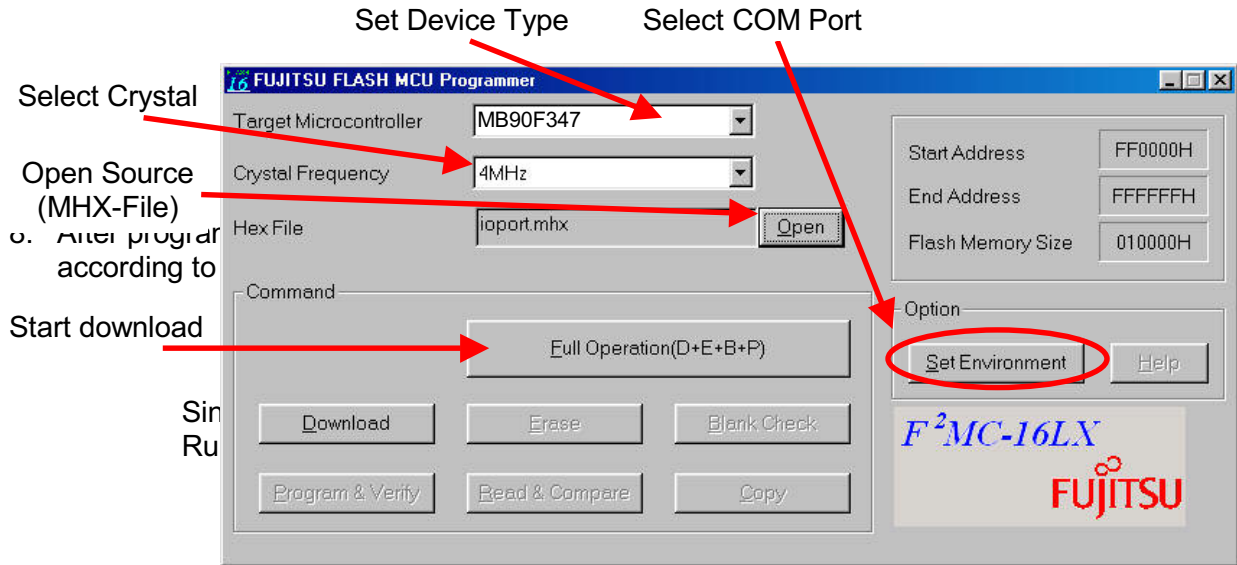

9. Power on the board. The user application is started directly.

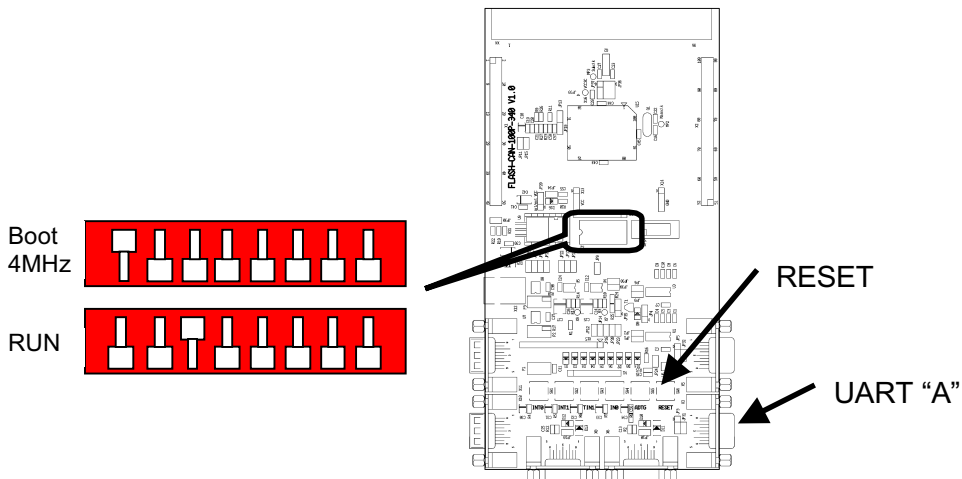

4.2 Synchronous Mode

In order to program the Flash-ROM synchronously via Serial I/O (SCI0) a special software has to be used, e.g. Fujitsu 'FlashKit' Tool. This tool is not available free.

Please contact our Web Site in order to get more information about the FlashKit-Tool:

<http://www.fme.gsdc.de/gsd.c.htm>: select ▶ Tools ▶ Programme ▶ MCU FlashKit

A dedicated Flash programming socket (X17) is provided on the evaluation-board for direct connection to the Fujitsu 'FlashKit'.

X17: Flash programming socket

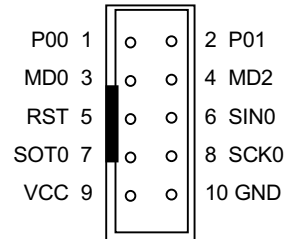

In case that the FlashKit-Tool is used, all Mode-settings will be done automatically by the FlashKit. This means that all DIP-switch S2 has to be set to the "OFF" position.

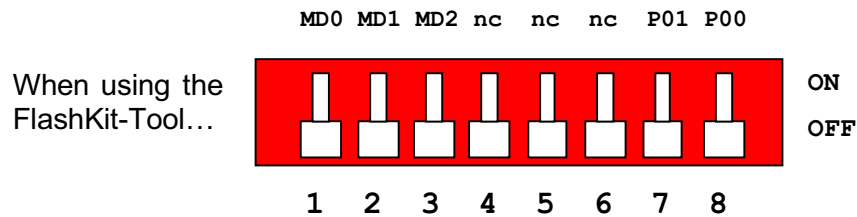

Please refer to the manual of the FlashKit for more information how to program a Flash-device by the synchronous-serial mode.

Note:

In case that another Programming-Tool is used and the Mode-settings have to be done manually then use the following configuration of DIP-switch S2 in order to select the synchronous-serial Flash-programming mode:



5 Connectors

5.1 Power connector (X12)

The following figure shows the power connection jack X12. This connector is used to connect an external unregulated DC power supply voltage (9V-12V DC) to the evaluation board.

Connector X12:

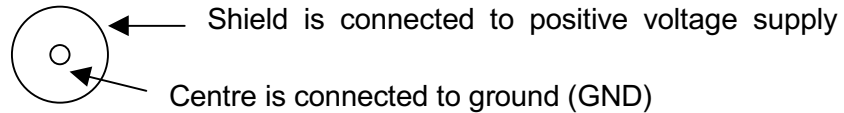

It is recommended to use 9V to keep the power dissipation to a minimum. Otherwise, an additional heat sink for the linear voltage regulator might be necessary.

5.2 Edge connector (X1, X2)

All pins of the microcontroller are directly connected to X1 and X2 as follows:

Connector	MCU Pins
X1 (1 – 50)	1 – 50
X2 (51 – 100)	51 – 100

The odd pin numbers are located on the one side and the even pin numbers are located on the other side of the connector.

On the PCB, the corresponding pin numbers of the μ C are written next to the connector pins.

5.3 UART"A", UART"B" connector (X3, X5)

Two 9-pin D-Sub female connectors are used for the serial interface UART"A" and UART"B".

TXD is the transmit output, RXD is the receive input.

The DTR or RTS signal can be used to generate a reset.

Please use 1:1 cable for PC-connection.

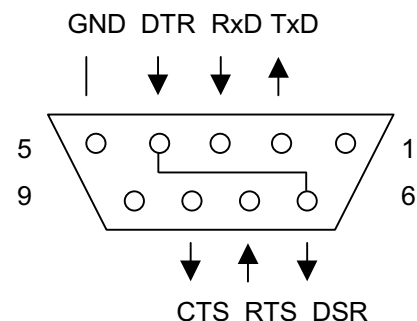

Connectors X3, X5:

5.4 LIN"A", LIN"B" Interface connector (X6, X8)

Two 9-pin D-Sub female connectors are used for the LIN-communication.

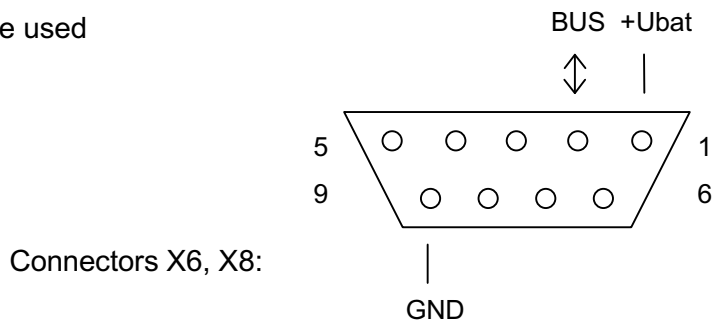

Connectors X6, X8:

5.5 CAN"A", CAN"B" Interface connector (X10, X11)

Two 9-pin D-Sub male connectors are used for the CAN interfaces.

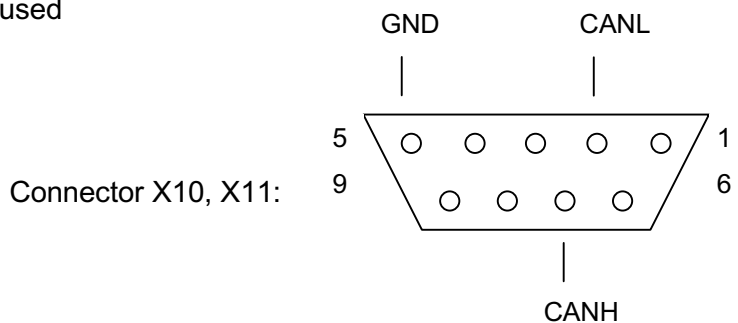

Connector X10, X11:

5.6 USER-LEDs & LC-Display (optional)

Eight LEDs are reserved for user-application. In order to disconnect the LEDs from the related microcontroller port, the resistor network N1 can be removed. Take care that, in case of asynchronous programming, the low-level of P00 and P01 is reached by the resistor-network N1 and the LEDs D1/D2. If N1 is removed in order to free the Port, then P00 and P01 have to be connected manually to GND. See chapter 4 for more details.

Instead of the user-LEDs one alphanumeric LC-Display (optional) can be connected.

The following control-signals are reserved:

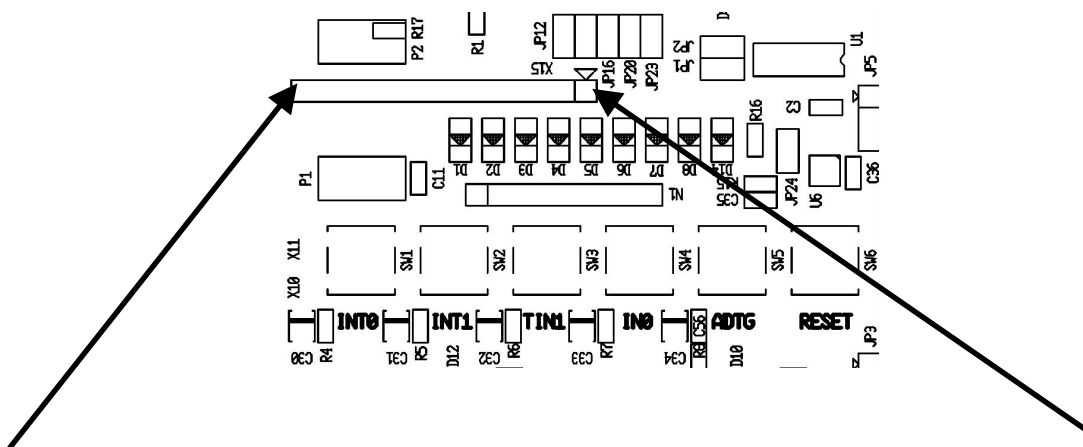

	14	13	12	11	10	9	8	7	6	5	4	3	2	1
LCD	D6	D5	D4	D3	-	-	-	-	E	R/W	RS	V0	VCC	GND
LED	D8	D7	D6	D5				D4	D3	D2	D1			
MCU	84	83	82	81				80	79	78	77			
Port	P07	P06	P05	P04				P03	P02	P01	P00			

5.7 VG96 connector (X4)

Connector-Pin cross reference table for MB90V340:

MB90340	Description	VG (X4)
1	P24/A20/IN0	A4
2	P25/A21/IN1	B4
3	P26/A22/IN2	C4
4	P27/A23/IN3	A5
5	P30/ALE/IN4	B5
6	P31/RDX/IN5	C5
7	P32/WRX/RX2	A6
8	P33/WRHX/TX2	B6
9	P34/HRQ/OUT4	C6
10	P35/HAKX/OUT5	A7
11	P36/RDY/OUT6	B7
12	P37/CLK/OUT7	C7
13	P40/X0A	(A16)
14	P41/X1A	(A17)
15	Vcc	ABC2
16	Vss	ABC3
17	C	-
18	P42/IN6/RX1	A8
19	P43/IN7/TX1	B8
20	P44/SDA0/FRCK0	C8
21	P45/SCL0/FRCK1	A9
22	P46/SDA1	B9
23	P47/SCL1	C9
24	P50/AN8/SIN2	A10
25	P51/AN9/SOT2	B10
26	P52/AN10/SCK2	C10
27	P53/AN11/TIN3	A11
28	P54/AN12/TOT3	B11
29	P55/AN13	C11
30	P56/AN14/DA00	A12
31	P57/AN15/DA01	B12
32	AVcc	-
33	AVRH	-
34	AVRL	-
35	AVss	-
36	P60/AN0/PPG0(1)	C12
37	P61/AN1/PPG2(3)	A13
38	P62/AN2/PPG4(5)	B13
39	P63/AN3/PPG6(7)	C13
40	P64/AN4/PPG8(9)	A14
41	P65/AN5/PPGA(B)	B14
42	P66/AN6/PPGC(D)	C14
43	P67/AN7/PPGE(F)	A15
44	Vss	ABC3
45	P70/AN16/INT0	B15
46	P71/AN17/INT1	C15
47	P72/AN18/INT2	B16
48	P73/AN19/INT3	C16
49	P74/AN20/INT4	B17
50	P75/AN21/INT5	C17

MB90340	Description	VG (X4)
51	MD2	A18
52	MD1	B18
53	MD0	C18
54	RSTX	A19
55	P76/AN22/INT6	B19
56	P77/AN23/INT7	C19
57	P80/TIN0/ADTG	A20
58	P81/TOT0/CKOT	B20
59	P82/SIN0/TIN2	C20
60	P83/SOT0/TOT2	A21
61	P84/SCK0	B21
62	P85/SIN1	C21
63	P86/SOT1	A22
64	P87/SCK1	B22
65	Vcc	ABC2
66	Vss	ABC3
67	P90/PPG1(0)	C22
68	P91/PPG3(2)	A23
69	P92/PPG5(4)	B23
70	P93/PPG7(6)	C23
71	P94/OUT0	A24
72	P95/OUT1	B24
73	P96/OUT2	C24
74	P97/OUT3	A25
75	PA0/RX0	B25
76	PA1/TX0	C25
77	P00/AD00/INT8	A26
78	P01/AD01/INT9	B26
79	P02/AD02/INT10	C26
80	P03/AD03/INT11	A27
81	P04/AD04/INT12	B27
82	P05/AD05/INT13	C27
83	P06/AD06/INT14	A28
84	P07/AD07/INT15	B28
85	P10/AD08/TIN1	C28
86	P11/AD09/TOT1	A29
87	P12/AD10/SIN3	B29
88	P13/AD11/SOT3	C29
89	P14/AD12/SCK3	A30
90	Vcc	ABC2
91	Vss	ABC3
92	X1	-
93	X0	-
94	P15/AD13/SIN4	B30
95	P16/AD14/SOT4	C30
96	P17/AD15/SCK4	A31
97	P20/A16/PPG9(8)	B31
98	P21/A17/PPGB(A)	C31
99	P22/A18/PPGD(C)	A32
100	P23/A19/PPGF(E)	B32

-	extVCC	ABC1
---	--------	------

6 Silk-Plot of the Board

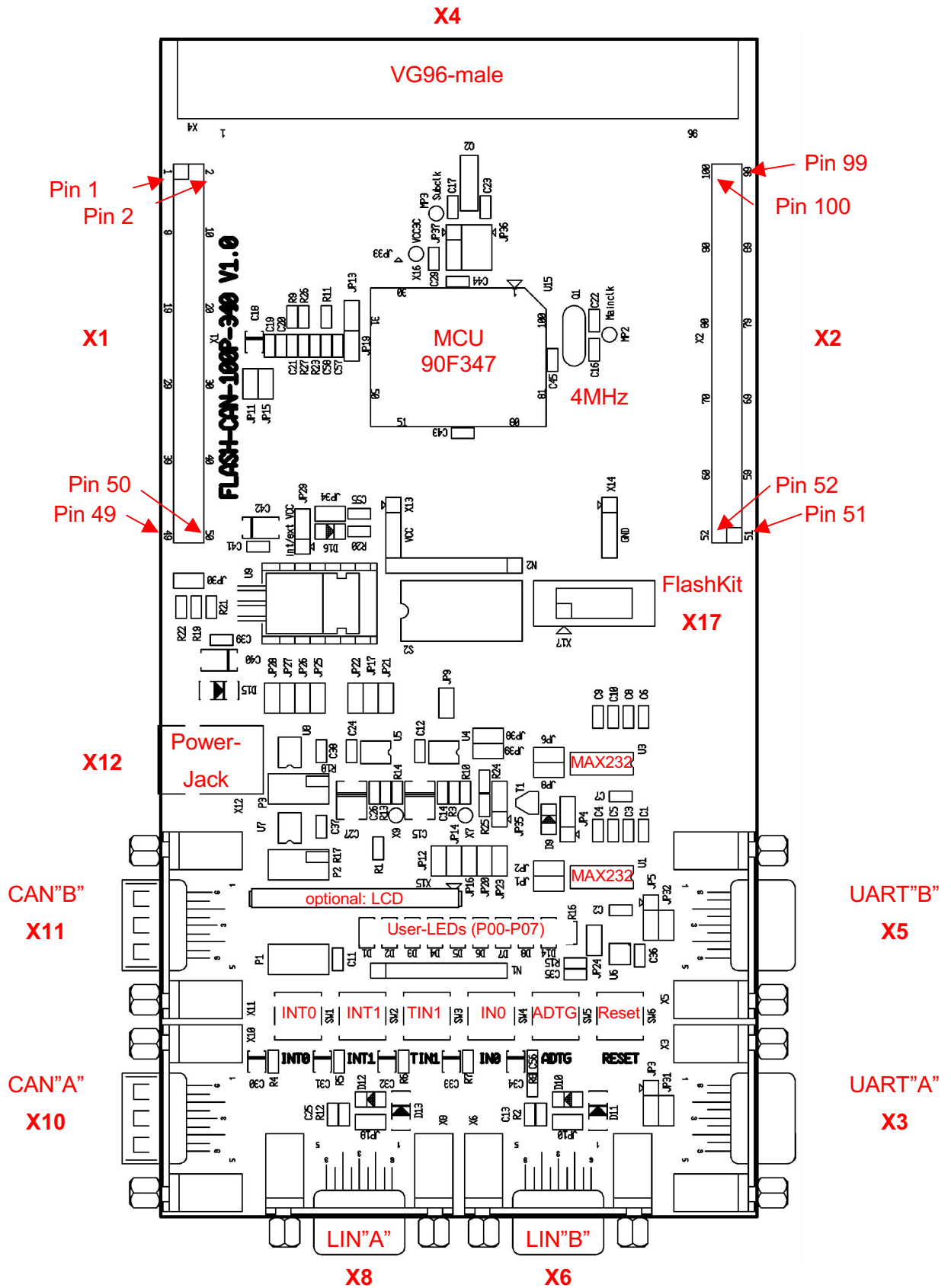

Note: In the silkplot R8 and C56 are swapped

7 Related Products

- ▶ FLASH-CAN-100P-340 Evaluation board for MB90340 and MB90860 series
- ▶ MB2147-01 Emulator debugger main unit
- ▶ MB2147-20 Emulation adapter
- ▶ MB2147-582 Emulator probe cable for package (FPT-100P-M06)
- ▶ MB90V340 Evaluation chip for MB90340 and MB90860 series
- ▶ MB90F347 Flash-Microcontroller with Subclock
- ▶ MB90F347S Flash-Microcontroller without Subclock
- ▶ MB90F867 Flash-Microcontroller without CAN controller
- ▶ NQPack100rb Socket for package FPT-100P-M06
(Tokyo Eletech Corp. www.tetc.co.jp/e_tet.htm)
- ▶ HQPack100rb179-V2 Header for NQPack100rb

8 Information in the WWW

Information about FUJITSU MICROELECTRONICS Products can be found on the following Internet pages:

Microcontrollers (8-, 16- and 32bit), Graphics Controllers
Datasheets and Hardware Manuals, Support Tools (Hard- and Software)

<http://www.fme.gsdc.de/gsdc.htm>

Memory products: Flash, SDRAM and FRAM

<http://www.fme.fujitsu.com/products/memory/index1.html>

Linear Products: Power Management, A/D and D/A Converters

<http://www.fme.fujitsu.com/products/linear/start.html>

Media Products: SAW filters, acoustic resonators and VCOs

<http://www.fme.fujitsu.com/products/media/index1.html>

For more information about FUJITSU MICROELECTRONICS

<http://www.fme.fujitsu.com/products/start.html>