

Sep.1.2019 Copyright 2019 HIROSE ELECTRIC CO., LTD. All Rights Reserved. In case of consideration for using Automotive equipment / device which demand high reliability, kindly contact our sales window correspondents.

1		2		3		4			
COUNT	DESCRIPTION OF REVISIONS	BY	CHKD	DATE	COUNT	DESCRIPTION OF REVISIONS	BY	CHKD	DATE
1	DIS-C-000585	T.K	E.K	07.07.27					

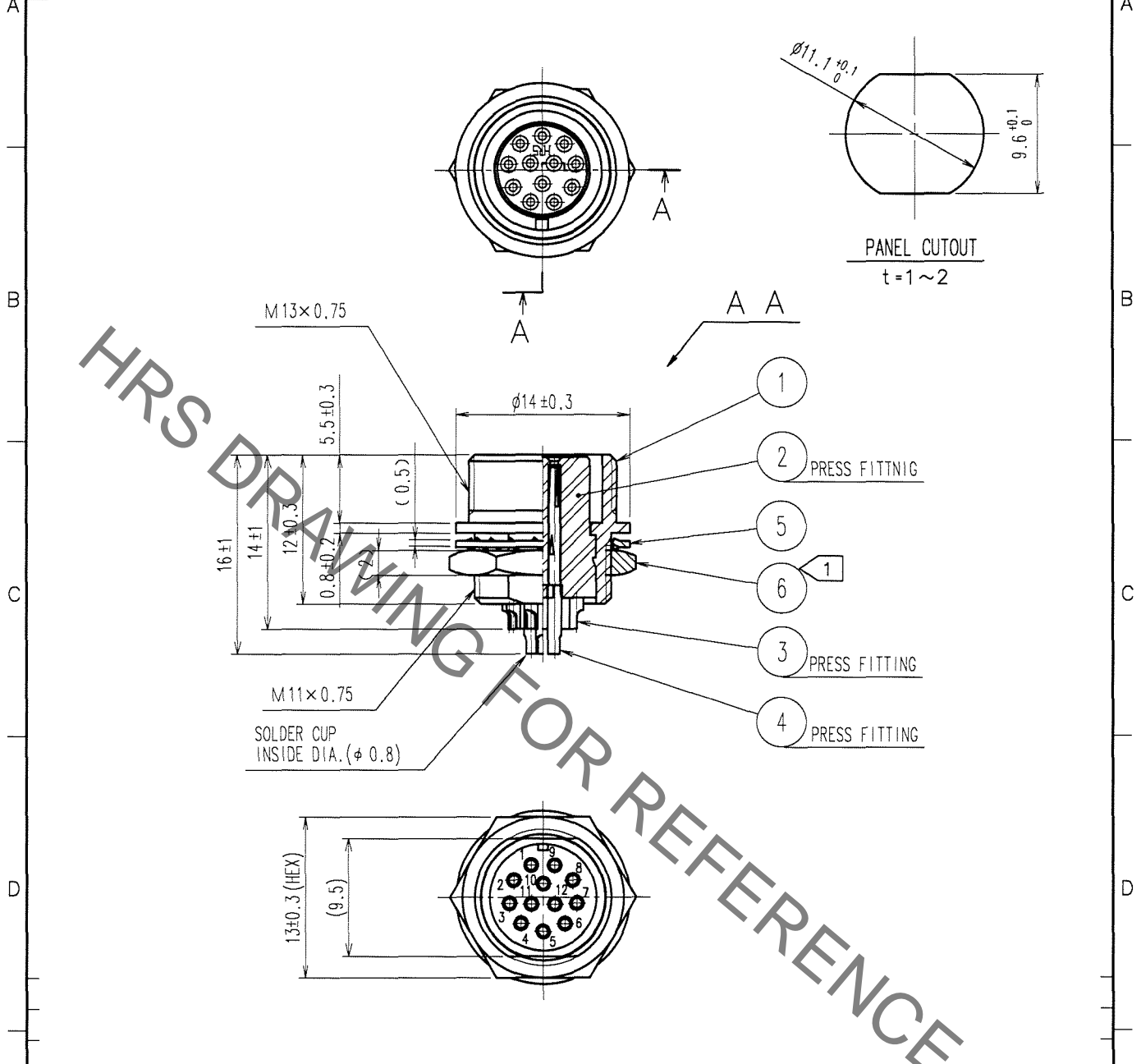

NOTE ① THE RECOMMENDED CLAMP TORQUE OF REF.NO. ⑥ : $2N \cdot m$.
 LOCTITE 242, HENKEL JAPAN OR EQUIVALENT IS RECOMMENDED TO PREVENT
 REF. NO. ⑥ FROM LOOSENING.

NO.	MATERIAL	FINISH, REMARKS	NO.	MATERIAL	FINISH, REMARKS
3	PHOSPHOR BRONZE	SILVER PLATING 2 μ m min.	6	BRASS	NICKEL PLATING
2	POLYAMIDE	(BLACK) UL94V-0	5	PHOSPHOR BRONZE	NICKEL PLATING
1	BRASS	NICKEL PLATING	4	PHOSPHOR BRONZE	SILVER PLATING 2 μ m min.

CODE NO. (OLD) CL	DRAWN D.MATSUNE '05 10 01	DESIGNED D.MATSUNE '05 10 01	CHECKED E.KUNII '05 10 13	APPROVED M.SATO '05 10 14	RELEASED
----------------------	---------------------------------	------------------------------------	---------------------------------	---------------------------------	----------

 SCALE 2 : 1 UNITS mm	DRAWING NO. EDC4-042429-73	PART NO. HR10A-10TR-12S(73)
	 HIROSE ELECTRIC CO., LTD.	CODE NO. CL110-0453-0-73

TO
R