

# PROFLY / PROBLADE

## Professional Radio Control

---



### ***PRO-BLADE8***

- Ready to Use Remote Control
- 8 Channel Systems
- Range:
  - PROFLY Up to 100 metres
  - PROBLADE Up to 500 metres
- Relay Outputs: Momentary, Latching, Timed
- Receiver IP65

#### **Applications**

- Lighting Control
- General Purpose Remote Switching
- Door Control
- Industrial remote Switching
- Access Control

The PRO series are general purpose remote control systems that uses a highly secure transmission protocol for reliable operation.

The receiver unit is IP65 rated with integral power supply containing industrial standard 'DIN Rail' 'receiver' and 'relay output' modules (interchangeable). Modules with higher switching capability are also available separately.

The relay outputs may be user set to operate as latching or momentary. Output 1 may be timed from 1-15 minutes.

Additional transmitters can be added using the easy learn procedure. Any transmitter switch can be mapped to any individual or combination of receiver output(s).

# PROFLY / PROBLADE Professional Radio Control

## Custom systems

We regularly supply pre-wired / bespoke systems; please contact our sales department for further assistance

## Receiver Unit

The receiver consists of interchangeable modules which are connected via ribbon cables. (as shown below)

## Antenna

The Antenna is held internally, this is to save drilling the enclosure on the top. This may have some effect to the range for specific applications which may require the antenna externally mounted. At all times please ensure that the antenna is pointing in a vertical direction and away from high interference sources.

## PROFLY / PROBLADE- 8 CHANNEL RECEIVER



## Ordering Information

Part Number	Description	Range** (Metres)	Freq (MHz)	Relay Outputs (each @230Vac)
PROFLY8	8 channel Remote Control System	100	434.92	8 x 12A
PROFLY16	16 channel Remote Control System	100	434.92	16 x 12A
PRO-BLADE8	8 channel Remote Control System	500	434.525	8 x 12A
PRO-BLADE16	16 channel Remote Control System	500	434.525	16 x 12A

\*\* Range stated is optimum, direct line of sight. In worst conditions this can be reduced significantly

## 1 Pre-Configuring the Remote Control System

There are three Steps:

1. Pre-Configure the 210Rx to operate with a type of Transmitter
2. Map the Transmitter(s) switch(es) to the 210Rx output(s)
3. Set the 210Rx outputs to be latching, momentary or timed.

### 1.1 Pre-Configure the 210Rx to operate with a Transmitter Series

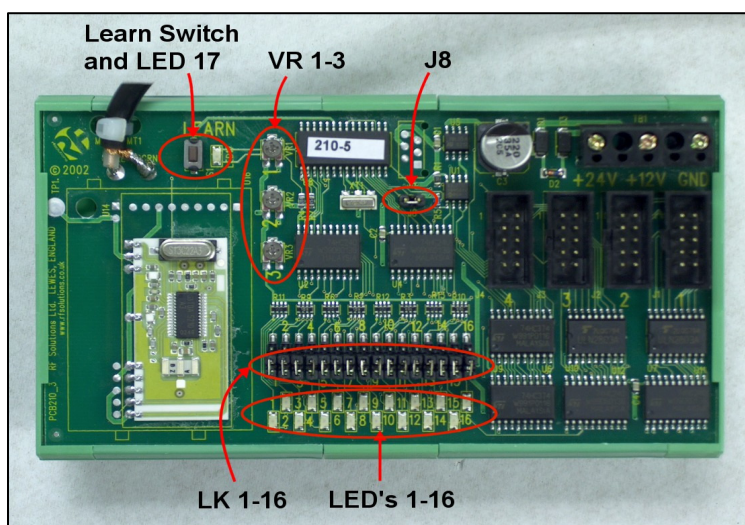

1. Ensure option link J8 is open.
2. Apply power to the 210Rx, All output LEDS flash alternately. This is factory reset default state.
3. Briefly Press any switch on the transmitter.  
The 210Rx will now confirm this by flashing LED 1 to show it is configured for use with a handheld transmitter.

Note: This will now happen at each power on.



# PROFLY / PROBLADE Professional Radio Control

## 1.2 Mapping a Transmitter Switch to a 210 Receiver Output

One or many transmitter switches may be mapped to one or many 210Rx outputs. Decide which switch on the Transmitter is to operate which output channel on the 210 receiver/decoder.

1. Press the 210 Rx learn switch until the led lights the desired output channel.
2. Operate the desired transmitter switch briefly
3. The LED on the 210Rx will extinguish.
4. Operate the desired transmitter switch briefly again
5. The LED on the 210Rx will turn on briefly and then extinguish.
6. The selected transmitter switch will operate the 210Rx output channel.

This procedure may be repeated for each transmitter and each 210Rx output required.

## 1.3 Configuration of the 210Rx Receiver Decoder Outputs

Option links LK 1-16 configure the operation of the outputs. Please note that the link status is read only on 'power up' and thus after changing the links, power must be removed and re-applied.

LK 1-16	Output 1	Outputs 2 -16
Open	Mom or Timed	Mom (The O/P operates for as long as the transmitter switch is held on)
Connected	Latch or Timed	Latch (The O/P changes state each time the Transmitter is operated)

### 1.3.1 Setting the Timed output (Channel 1)

This is set by VR1 with a delay of from 0 to 15 minutes. To set the time delay:

1. Remove power.
2. Place a shorting link header on option link J8.
3. Apply power
4. Depress and release the learn button twice.
5. The 210Rx will then enter the 'time set mode'
6. LED1 will illuminate, indicating that output 1 time delay is to be set.
7. Using a fine screwdriver, adjust potentiometer VR1.
8. An indication of the time delay set is shown by LED's 9-15.

After setting the timed output the unit must be powered down and option link header J8 removed before it can be used.

## 1.4 Erasing the 210Rx Receiver Outputs (Return to Factory Default State)

1. To completely erase the 210Rx decoder's memory, press and hold the 210Rx learn switch.
2. The learn LED (LED 17) will illuminate
3. Hold the Learn switch until the learn LED extinguishes (approx 10 seconds).
4. Release the learn button and all the output LED's 1-16 will now flash alternately to indicate that all encoder data has been erased and the 210Rx has returned to factory default state.

**Note:** It is not possible erase individual transmitters.

### 1.5 Connecting output Modules to the 210 Receiver

The receiver has 16 outputs. These are connected to the relay output module via a ribbon cable. The outputs are presented according to the following table.

210 receiver Connector	O/P Channels
1	1 - 4
2	5 - 8
3	9 - 12
4	13 - 16

### 1.6 Relay Outputs

Each output relay provides an isolated switch. Connections are Common (COM), Normally Open (NO), Normally Closed (NC).

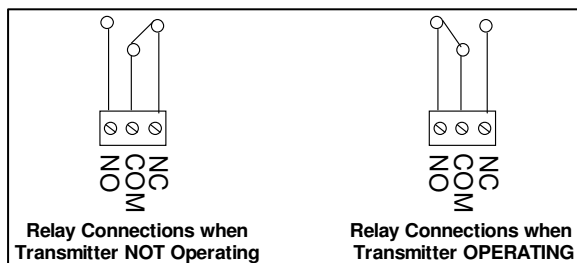

## 2 Antenna and Range

### 2.1 Antenna

The system includes an antenna. It is situated within the enclosure (to save penetrating the enclosure). If the range is inadequate then it may be necessary to mount the antenna protruding from the enclosure. This may be easily fitted using the provided panel mount BNC socket. The antenna cable may be extended however please note that typically there is a 50% range reduction with every 3metres of coax cable used! For increasing range performance a +3dB gain antenna is available. This is supplied with wall mounting bracket and 2metres of coax cable, it plugs in directly to the BNC connector.

### 2.2 Range

The antenna choice and position directly controls the system range. Keep it clear of other metal in the system. The best position is protruding from the top of the product. This is often not desirable for practical or ergonomic reasons and thus a compromise may be needed. If an internal antenna must be used then try to keep it away from other metal items, and in particular large ones like transformers, batteries and PCB tracks and earth planes.

Note that the space around the antenna is as important as the antenna itself. All radio systems are dependant on a radio signal being received through airspace.

The range quoted is the optimal in direct line of sight without obstacles and in good atmospheric conditions.

### 2.3 Signal integrity

In systems where many encoders are in close proximity there may be occasions when, due to signal overlay between encoders, it is difficult or impossible to guarantee system integrity. In such circumstances it is the responsibility of the installer to ensure that the system performance is adequate for the purposes of the installation.



# PROFLY / PROBLADE

## Professional Radio Control

### Technical Specifications

#### Transmitter

##### FireBlade

Dimensions 90 x 54 x 27mm  
 Battery CR2032 Lithium Cell

#### Receiver Unit

Dimensions 315 x 235 x 130mm  
 Insulation class II  
 Sealed hinged lid screws  
 DIN Rails mounted on steel plate  
 Integrated 12Vdc moulded Power Supply  
 5 Amp Fused terminal block  
 Material GW PLAST 120 °C

A 12Vdc power supply is incorporated. 12Vdc is presented on a fused terminal block. A Gland is supplied to enable power to enter the enclosure.

Learning Capacity: The receiver has the capacity to learn upto 50 units  
 (Where 1 unit is defined as a button on a transmitter)

Dimensions  
 External 315 x 235 x 130mm  
 Internal 300 x 220 x 120mm  
 DIN Rail length 1 285mm  
 DIN Rail length 2 180mm

#### Technical Specifications

Input Voltage 110-240Vac  
 Output Voltage 12Vdc +/-5%  
 Output Current 1A  
 Output Polarity: White Dashed Wire =+12V

Storage Temperature: -10 to +70° Celsius.

Operating Temperature: 0 to +55° Celsius.

Electrical Characteristics	Min	Typical	Max	Units
Supply Voltage: 12V Supply	10	12	16	V
Supply Voltage: 24V Supply	21	24	30	V
Supply Current : Quiescent		25		mA
Time from Tx Switch depressed to 210Rx output			100	mS
Time from Tx Switch release to Decoder output			200	mS
Switched output Voltage (I out = 1mA)				
Logic Low	0	0.2	0.8	V
Logic High	3.5	3.8	5	V

**R. F. Solutions Ltd.,**  
**Unit 21, Cliffe Industrial Estate, South Street, Lewes,**  
**E. Sussex, BN8 6JL, England**

**Tel +44 (0)1273 898 000 Fax +44 (0)1273 480 661**

**Email sales@rfsolutions.co.uk**

**http://www.rfsolutions.co.uk**

*RF Solutions is a member of the Low Power Radio Association*

