

# Dupline Car Park System

## Type GP6289 000x-US

### Passive LED Indicator for Sensor



- Low current consumption
- Passive indicator for sensor
- No programming. Just hardware connected
- GP6289 0001-US is passive red/green LED indicator
- GP6289 0002-US is passive red/blue LED indicator
- GP6289 0002-US is specially designed for reservation purpose
- cULus approved

## Product Description

The passive LED indicator for sensor is part of the car park system which contains other variants of sensors, passive displays and monitor modules. The GP6289 000x-US is a passive LED indicator made as indicator for sensor GP6240 2224 724-US.

The passive sensor is normally mounted outside the parking bay so that a passing vehicle can easily identify the status of the parking bay. The GP6289 0002-US LED indicator is particularly designed for reservation of parking bays.

## Ordering key

**GP 6289 000x-US**

Type: Dupline<sup>®</sup>  
Housing  
Input type  
Channels  
Inputs

## Input/Output Specifications

RJ12 connector	Not in use
2x3-pin connector	Not in use
1x2-pin connector	Connector must be connected correctly from dot to dot etc. If the wire connection is reversed the LED will show the opposite. E.g. occupied bay will show green (blue) and free bay will show red. See drawing "Example of connection".

## Type Selection

GP6289 0001-US	Passive red/green LED indicator
GP6289 0002 US	Passive red/blue LED indicator

## Supply Specifications

Power supply:	Powered from sensor module GP6240 2224 724-US
Max. supply current	5 mA
Power consumption:	< 0.7 Watt

## Environment

- Protection: IP 34
- Operating temperature: -40°C to 70°C (-40°F to 158°F)
- Storage temperature: -40°C to 85°C (-40°F to 185°F)
- Pollution Degree: 3 (IEC 60664)
- Dimensions: Ø118 x 76 mm
- Material: The case is made of polypropylene. The sensor lid is made of clear Polycarbonate.

## General Specifications

LED indication:	
Occupied:	Red LED continuously lit
Space available:	Green LED continuously lit
GP6289 0001-US	
Reserved:	Blue LED continuously lit
GP6289 0002-US	
Approval	cULus (UL60950)

## Mode of Operation

GP6289 000x-US is a passive LED indicator used for status indication of a parking bay and is located outside the space. The indicator is connected to the appropriate sensor by means of a 2-wire cable.

The indicator is a passive unit, with no possibilities of adjustment or interface.

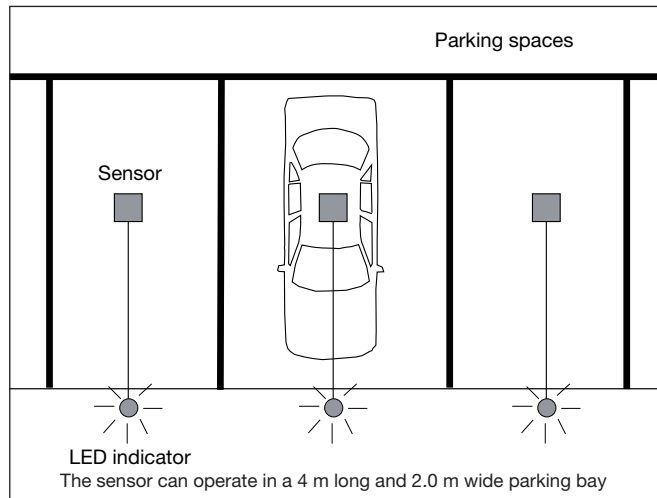
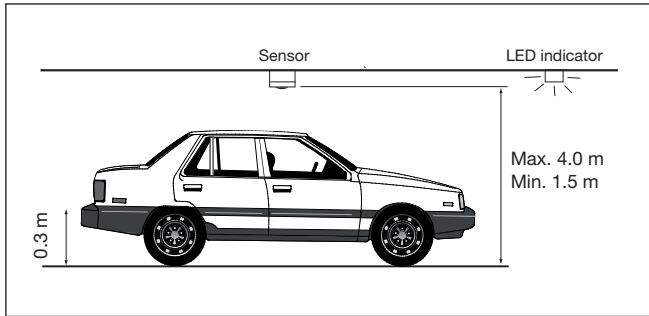

## Bottom part: mounted in ceiling

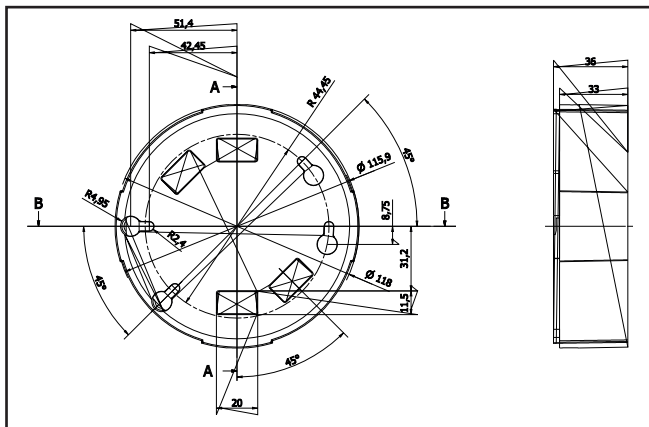

## Dimensions

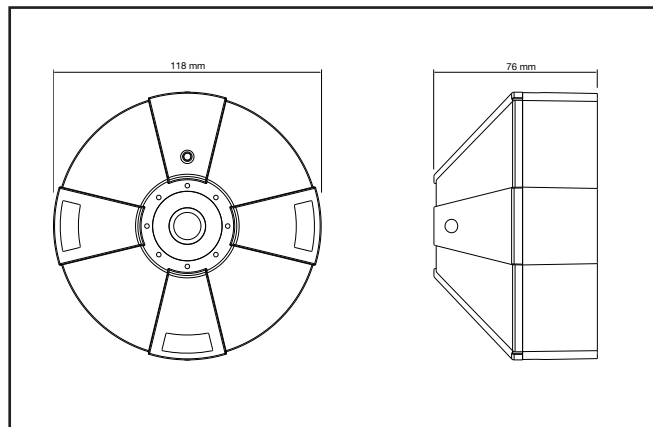

## Example of connection

