

**ASA (10W) Isolated DC/DC Converter Module**  
**Industry Standard Size, 1.25"x0.8"x0.4"**  
**18-36V/36-75V Inputs, 2.5V/3.3V/5V/12V Outputs**

The ASA (10W) Isolated DC/DC Converter is Astec's 2:1 input voltage family for low power applications. With efficiency up to 82% typical for 5V module, this product is allowed to work at operating temperature range from -40°C to 60°C and an input voltage range of 2:1. Single-output models are available for a wide range of applications in telecommunication, transportation equipment, etc.. Housed in small package, 1.25"x0.8"x0.4", with industry standard pinout, 24-pin DIP, ASA family eases the PCB designs and mechanical designs of customers' end products.



**Industry Standard Size**  
**1.25" x0.80" x 0.40"**

Special Features

- High efficiency, 82%@5V
- -40°C to 85°C case surface operating temperature
- Input / Output isolation 1.5KVdc
- Low output ripple and noise
- Shielded metal case with size (1.25"x0.8"x0.4")
- Industrial standard pinout (24-pin DIP)
- Lead-free soldering pins
- Fixed switching frequency (350KHz)

Environmental Specifications

- Operating temperature: -40°C to +60°C
- Storage temperature: -55°C to +105°C
- MTBF: >800K hours
- ROHS Compliant



Electrical Parameters

Input

**Input range** 18-36 VDC; 36-75 VDC  
**Efficiency** 82%@ 5V (Typical)

Output

**Regulation (Line, Load, Temp)** <2%  
**Ripple and noise** 2% typical (100mV p-p max@ 5V)  
**Transient Response** 6% max deviation with 50% load to full load 300uS (max) recovery

**Short Circuit Protection** Indefinite

Safety

Designed to meet EN60950 (up to SELV limit)



## Technical Reference Note ASA (10W) Family



---

### ASA (10W) SERIES

THIS SPECIFICATION COVERS THE REQUIREMENTS  
FOR AN INDUSTRY STANDARD PACKAGE OF 1.25"x0.8"x0.4",  
2:1 INPUT RANGE, 10W, SINGLE OUTPUT ISOLATED DC/DC CONVERTER

#### PART NUMBERS

MODEL NAME / SIS CODE	Nominal Vin / Range of Vin	Vout / Iout
ASA03G24-L	24V / 18-36V	2.5V / 3A
ASA03F24-L	24V / 18-36V	3.3V / 3A
ASA02A24-L	24V / 18-36V	5V / 2A
ASA00B24-L	24V / 18-36V	12V / 0.833A
ASA03G48-L	48V / 36-75V	2.5V / 3A
ASA03F48-L	48V / 36-75V	3.3V / 3A
ASA02A48-L	48V / 36-75V	5V / 2A
ASA00B48-L	48V / 36-75V	12V / 0.833A



## Technical Reference Note ASA (10W) Family



### ELECTRICAL SPECIFICATIONS

Unless otherwise indicated, specifications apply over all operating input voltage and temperature conditions.  
Standard test condition on a single unit.

Tambient :	25°C
+Vin :	24V $\pm$ 2% (ASAxxx24-L) 48V $\pm$ 2% (ASAxxx48-L)
-Vin :	return pin for +Vin
+Vout :	connect to load
-Vout :	connect to load (return)

### ABSOLUTE MAXIMUM RATINGS

Stresses in excess of the absolute maximum ratings can cause permanent damage to the device. These are absolute stress ratings only. Functional operation of the device is not implied at these or any other conditions in excess of those given in the operational sections of the IPS. Exposure to absolute maximum ratings for extended periods can adversely affect device reliability.

Parameter	Device	Symbol	Min	Typ	Max	Unit
a) Input Voltage:						
Continuous:	ASAxxx24-L	$V_I$	0	-	36	Vdc
Transient (100ms)	ASAxxx24-L	$V_{I,trans}$	0	-	44	Vdc
Continuous:	ASAxxx48-L	$V_I$	0	-	75	Vdc
Transient (100ms)	ASAxxx48-L	$V_{I,trans}$	0	-	88	Vdc
b) Operating Temperature						
Ambient	All	$T_a$	-40	-	60	°C
Case Surface		$T_c$	-40	-	90	°C
c) Storage Temperature	All	$T_{STG}$	-55	-	105	°C
d) Operating Humidity	All	-	-	-	95	%
e) I/O Isolation (Conditions : 0.5mA for 60 sec)						
Input-Output	All	-	-	-	1500	Vdc
f) Output Power	2.5V	$P_{o,max}$	-	-	7.5	W
	Others	$P_{o,max}$	-	-	10	W



## Technical Reference Note ASA (10W) Family



### INPUT SPECIFICATIONS

Parameter	Device	Symbol	Min	Typ	Max	Unit	
a) Operating Input Voltage	ASAxxx24-L	$V_I$	9	24	36	$V_{DC}$	
	ASAxxx48-L	$V_I$	18	48	75	$V_{DC}$	
b) Maximum Input Current ASAxxx24-L ( $V_I = 0$ to $V_{I,max}$ : $I_o = I_{o,max}$ )	2.5V	$I_{I,max}$	-	-	1.3	A	
	3.3V	$I_{I,max}$	-	-	1.5	A	
	5V	$I_{I,max}$	-	-	1.4	A	
	12V	$I_{I,max}$	-	-	1.2	A	
	ASAxxx48-L ( $V_I = 0$ to $V_{I,max}$ : $I_o = I_{o,max}$ )	2.5V	$I_{I,max}$	-	-	0.7	A
		3.3V	$I_{I,max}$	-	-	0.8	A
		5V	$I_{I,max}$	-	-	0.7	A
		12V	$I_{I,max}$	-	-	0.7	A
c) No Load Input Power ( $V_I = V_{I,nom}$ )	All	-	-	-	0.5	W	
d) External Fuse Ratings	2.5V		-	2	-	A	
	ASAxxx24-L	3.3V	-	2	-	A	
		5V	-	2	-	A	
		12V	-	2	-	A	
	ASAxxx48-L	2.5V	-	1	-	A	
		3.3V	-	1	-	A	
		5V	-	1	-	A	
		12V	-	1	-	A	

**CAUTION: This power module is not internally fused. An input fuse must always be used.**



## Technical Reference Note ASA (10W) Family



### OUTPUT SPECIFICATIONS

Parameter	Device	Symbol	Min	Typ	Max	Unit
a) Output Voltage Setpoint ( $V_I = V_{I,min}$ to $V_{I,max}$ ; $I_o = I_{o,max}$ ; $T_A = 25^\circ\text{C}$ )	2.5V	$V_{o,set}$	2.45	2.50	2.55	$V_{dc}$
	3.3V	$V_{o,set}$	3.23	3.30	3.37	$V_{dc}$
	5V	$V_{o,set}$	4.90	5.00	5.10	$V_{dc}$
	12V	$V_{o,set}$	11.76	12.00	12.24	$V_{dc}$
b) Output Regulation: Line ( $V_I = V_{I,max}$ to $V_{I,min}$ ; $I_o = I_{o,max}$ )	All	-	-	-	0.8	%
	All	-	-	-	1.2	%
	All	-	-	-	1.0	% $V_o$
c) Output Ripple and Noise (Across $1\mu\text{F}$ @50V, X7R ceramic capacitor & $10\mu\text{F}$ @25V tantalum capacitor) See Figure 1. Peak-to-Peak (5 Hz to 20 MHz)	2.5V	-	-	-	100	mVp-p
	3.3V	-	-	-	100	mVp-p
	5V	-	-	-	100	mVp-p
	12V	-	-	-	120	mVp-p
d) Rated Output Current Single Output	2.5V	$I_o$	300	-	3000	mA
	3.3V	$I_o$	300	-	3000	mA
	5V	$I_o$	200	-	2000	mA
	12V	$I_o$	80	-	833	mA
e) Efficiency ( $V_I = V_{I,nom}$ ; $I_o,max$ ; $T_A = 25^\circ\text{C}$ )	2.5V	-	-	77	-	%
	3.3V	-	-	79	-	%
	5V	-	-	82	-	%
	12V	-	-	83	-	%
f) Switching Frequency	All	-	315	350	385	KHz



## Technical Reference Note ASA (10W) Family



### OUTPUT SPECIFICATIONS (Cont.)

Parameter	Device (Series)	Symbol	Min	Typ	Max	Unit
g) Dynamic Response : ( $\Delta I_o/\Delta t = 0.08A/\mu s$ ; $V_I = V_{I,nom}$ ; $T_A = 25^\circ C$ )						
Load Change from $I_o = 50\%$ to 100% of $I_{o,max}$ :	2.5V/3.3V/5V	-	-	-	6	% $V_o$
Peak Deviation Settling Time (to $V_{o,nom}$ )	12V	-	-	-	2	% $V_o$
	All	-	-	-	300	$\mu Sec$
i) Output Voltage Overshoot ( $I_o = I_{o,max}$ ; $T_A = 25^\circ C$ )	All	-	-	4	6	% $V_o$

### FEATURE SPECIFICATIONS

Parameter	Device (Series)	Symbol	Min	Typ	Max	Unit
Undervoltage Lockout						
Turn-on Point	ASAxxx24-L	-	-	14	18	V
	ASAxxx48-L	-	-	26	36	V
Turn-off Point	ASAxxx24-L	-	-	10	-	V
	ASAxxx48-L	-	-	20	-	V
Isolation Capacitance	All	-	-	1000	-	PF
Isolation Resistance	All	-	10	-	-	$M\Omega$
Calculated MTBF ( $I_o = I_{o,max}$ ; $T_A = 25^\circ C$ )	All	-	800K	-	-	Hours
Weight	All	-	-	-	20	g



## Technical Reference Note ASA (10W) Family



---

### **Basic Operation and Features**

The ASA converters were designed specifically to address applications where high power density is required. These modules provide 1500V isolation and operate from the input ranges of 18V-36V and 36V-75V with standard features such as short circuit protection.

### **Output Current Protection**

To provide protection in a short circuit condition, the converter is equipped with current limiting circuitry and can endure the fault condition for an unlimited duration. At the point of current-limit inception, the converter goes into "Hiccup Mode", causing the output current to be limited both in peak and duration. The converter operates normally once the output current is brought back into its specified range.

### **TEST SETUP**

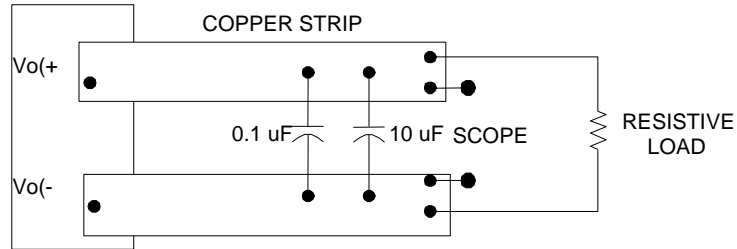

Note: Use a 0.1 $\mu$ F @50V X7R ceramic capacitor and a 10 $\mu$ F @ 25V tantalum capacitor. Scope measurement should be made using a BNC socket. Position the load between 51 mm and 76 mm (2 in. and 3 in.) from module.

**Figure 1 : Peak-to-Peak Output Noise Measurement Test Setup.**

Performance Curves – Efficiency Curve

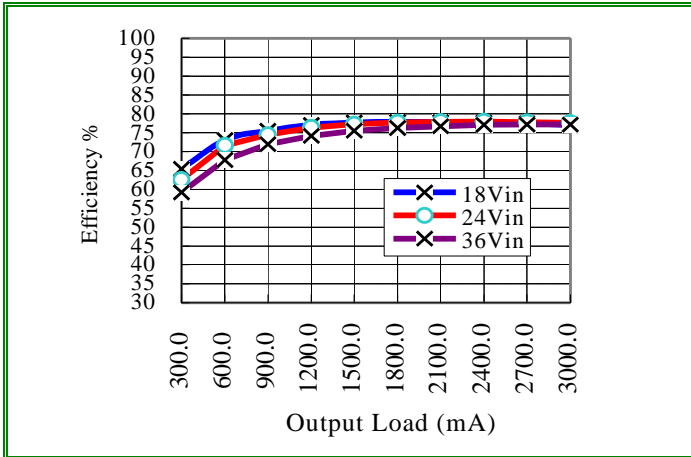

Efficiency vs. Load @ +25° Ambient, ASA03G24-L

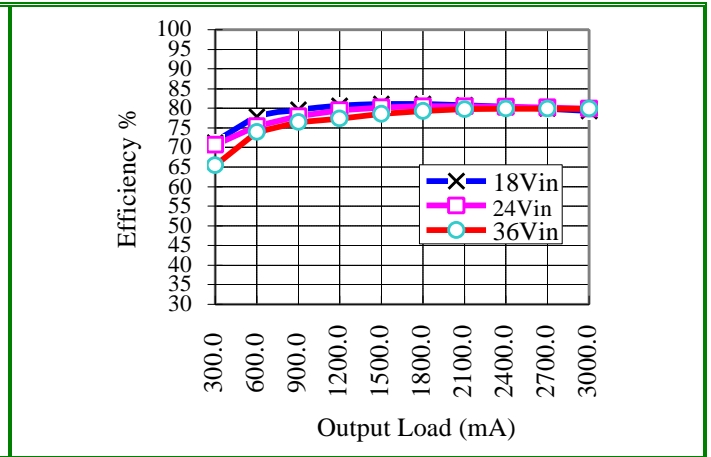

Efficiency vs. Load @ +25° Ambient, ASA03F24-L

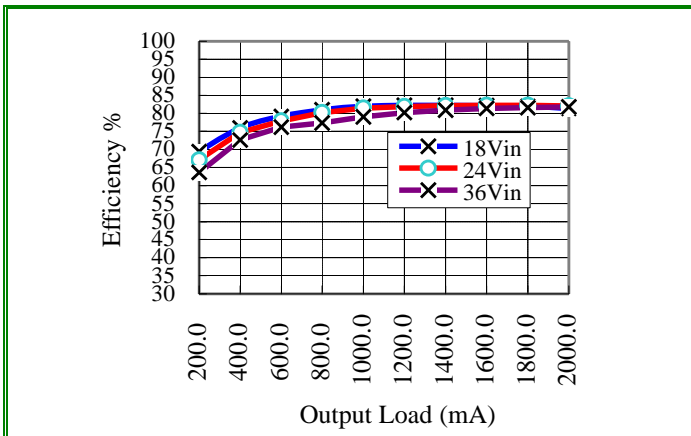

Efficiency vs. Load @ +25° Ambient, ASA02A24-L

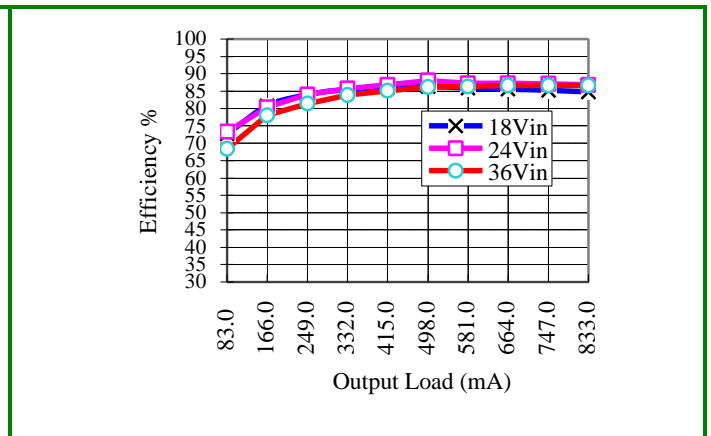

Efficiency vs. Load @ +25° Ambient, ASA00B24-L

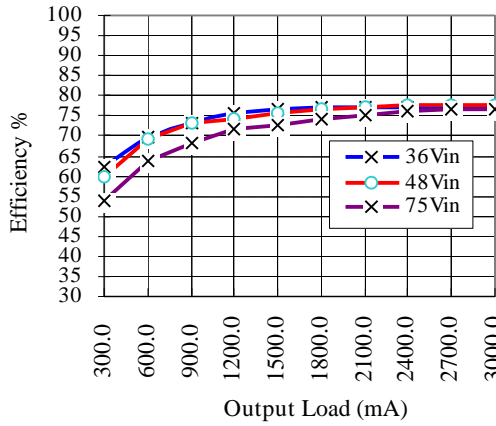

**Efficiency vs. Load @ +25° Ambient, ASA03G48-L**

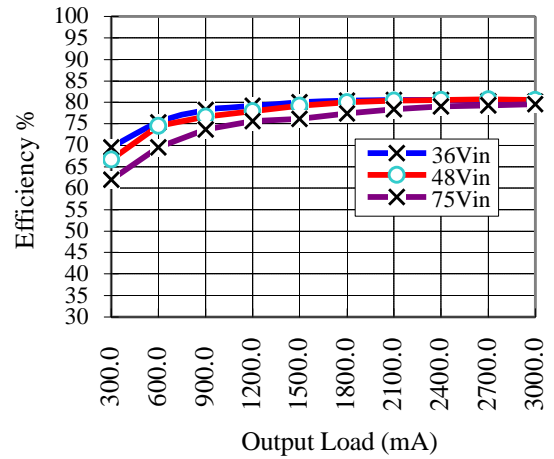

**Efficiency vs. Load @ +25° Ambient, ASA03F48-L**

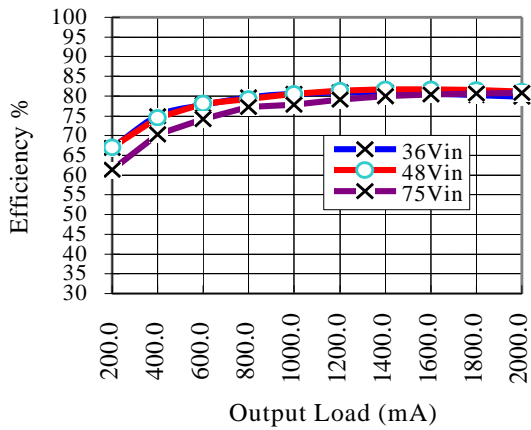

**Efficiency vs. Load @ +25° Ambient, ASA02A48-L**

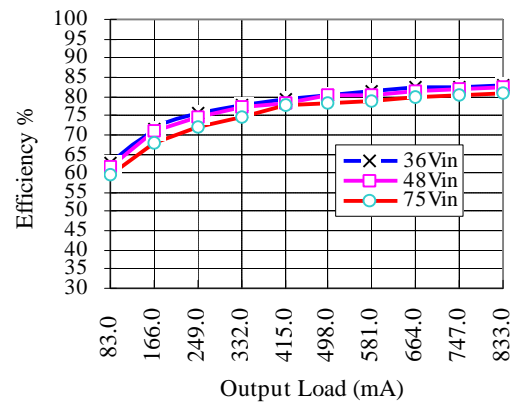

**Efficiency vs. Load @ +25° Ambient, ASA00B48-L**



# Technical Reference Note ASA (10W) Family



## Performance Curves

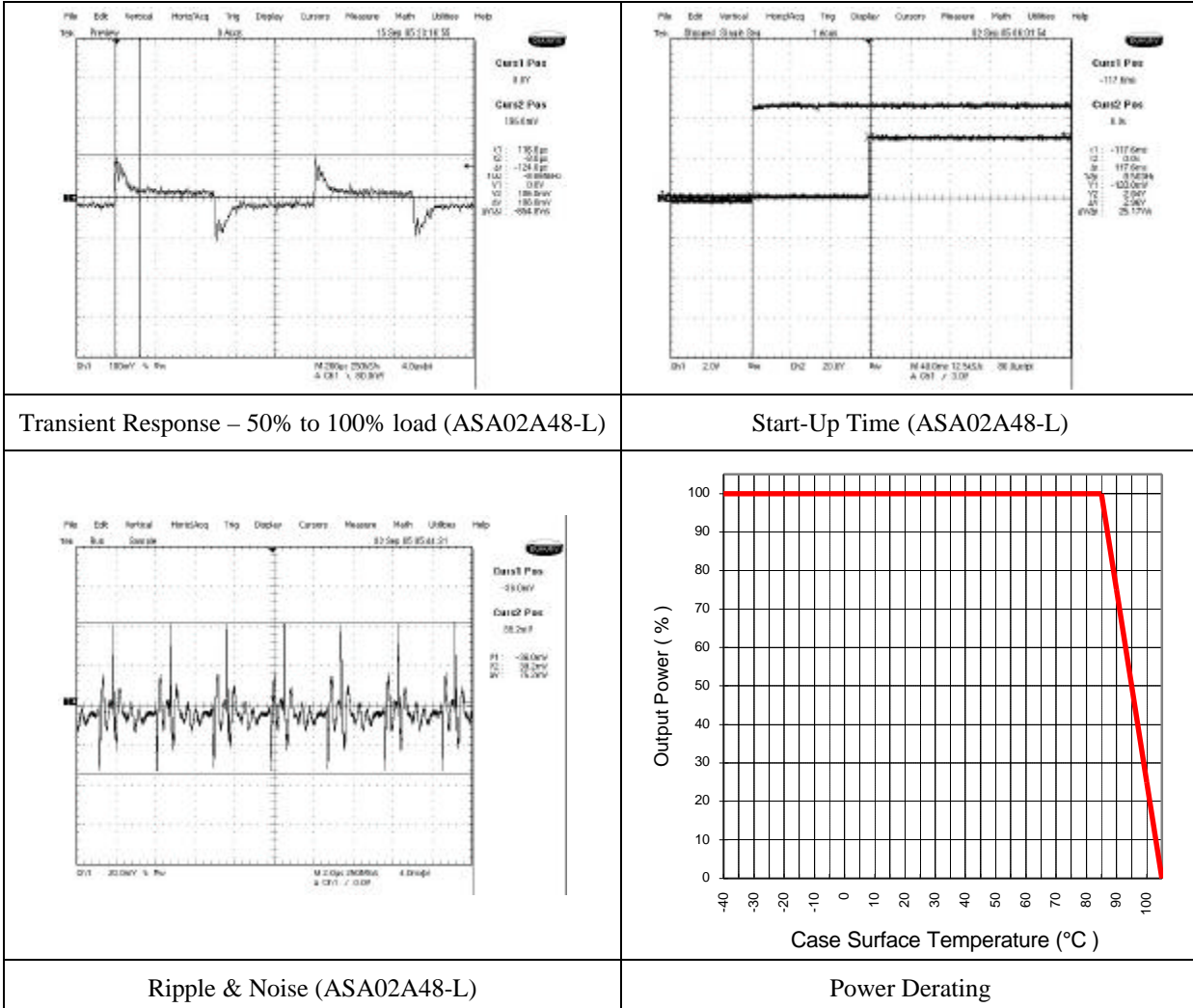





Mechanical Dimensions and Module Pin Assignment

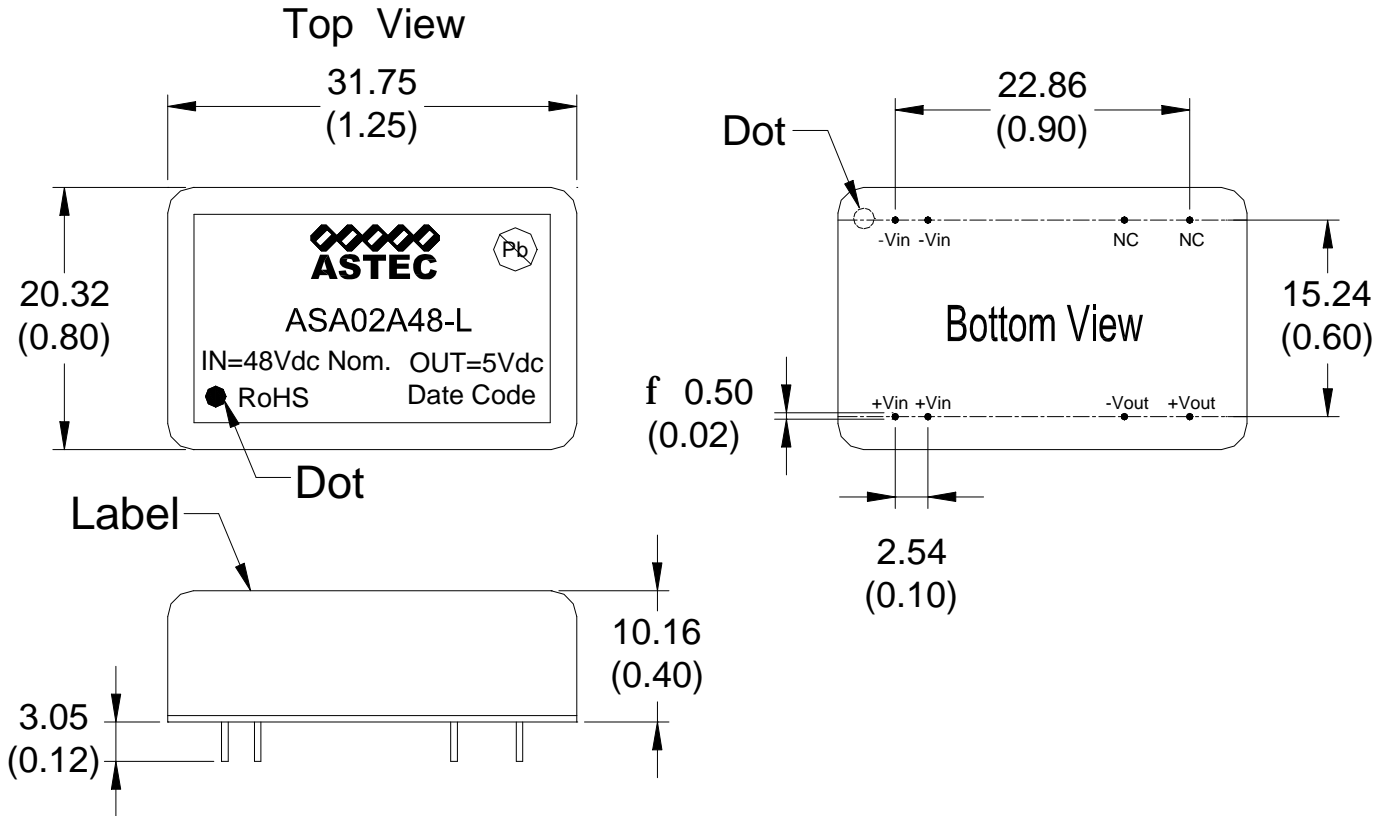

Outline Drawing for ASA Series

Package Information

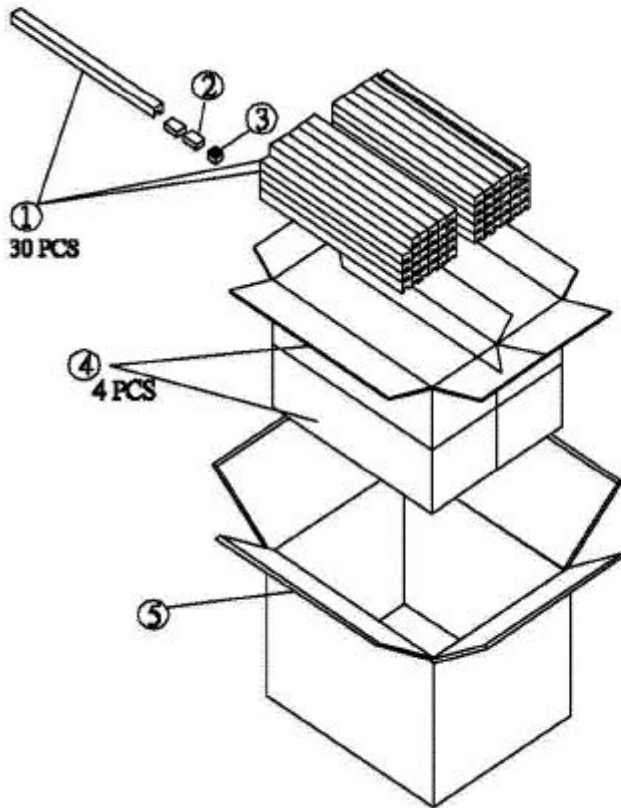

1. PACKING TUBE: 345\*22.2\*16.7mm ; ONE TUBE = 10 PCS
2. PRODUCTS: ASA SERIES
3. STOPPER
4. INNER CARTON: 388\*159\*263mm  
ONE INNER CARTON = 30 TUBES = 300PCS
5. OUTER CARTON: 405\*334\*263mm  
ONE OUTER CARTON = 4 INNER CARTONS = 1200PCS

STANDARD TOLERANCE LIMITS UNLESS OTHER SPECIFIED.	
RANGE	TOLERANCE
>0~3	±0.10
>3~6	±0.15
>6~30	±0.18
>30~120	±0.20

### Recommended Lead-Free Wave Soldering Temperature Profile

