

A-GAGE MINI-ARRAY Two-Piece Measuring Light Screen



Installation Guide

A-GAGE MINI-ARRAY two-piece measuring light screen configured for vehicle separation

For the latest technical information about this product, including specifications, dimensions, and wiring, see www.bannerengineering.com.

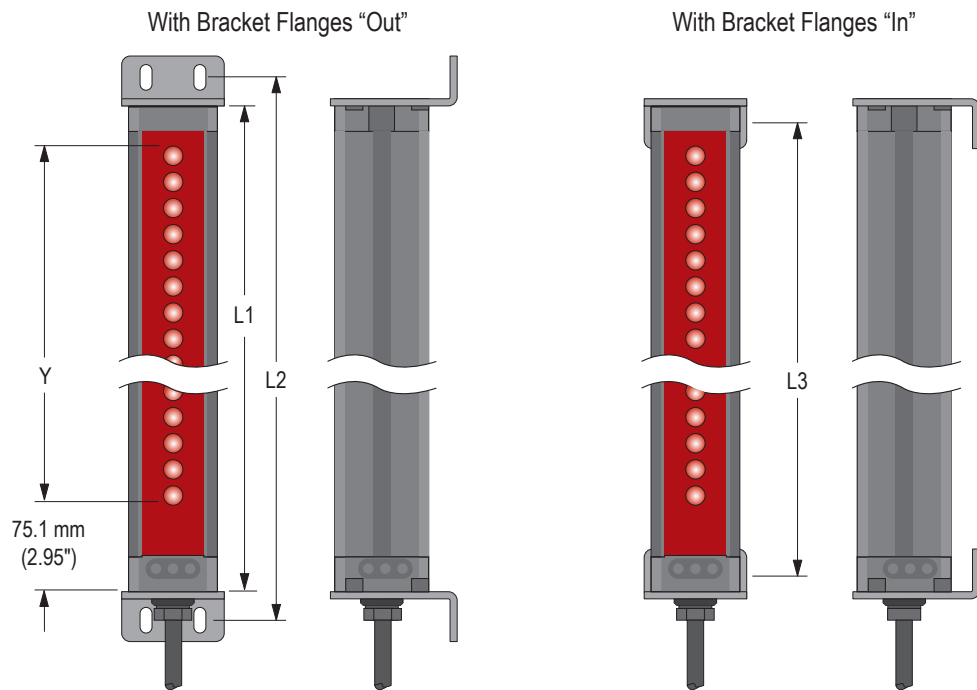

Emitter/Receiver Models ¹	Array Length (Y)	Housing Length (L1)	Distance Between Bracket Holes		Total Beams	Sensor Scan Time ²	
			L2	L3		Interlaced Scan ³	Straight Scan
MAE616 Emitter MAR616NX485 Receiver	143 mm (5.62")	231 mm (9.1")	262 mm (10.3")	205 mm (8.1")	8	1.4 ms	0.9 ms
MAE1216 Emitter MAR1216NX485 Receiver	295 mm (11.62")	384 mm (15.1")	414 mm (16.3")	357 mm (14.1")	16	2.5 ms	1.5 ms
MAE1816 Emitter MAR1816NX485 Receiver	448 mm (17.62")	536 mm (21.1")	567 mm (22.3")	510 mm (20.1")	24	3.6 ms	2.0 ms
MAE2416Q Emitter MAR2416NX485 Receiver	600 mm (23.62")	689 mm (27.1")	719 mm (28.3")	662 mm (26.1")	32	4.8 ms	2.6 ms
MAE3016 Emitter MAR3016NX485 Receiver	752 mm (29.62")	841 mm (33.1")	871 mm (34.3")	815 mm (32.1")	40	5.9 ms	3.2 ms
MAE3616 Emitter MAR3616NX485 Receiver	905 mm (35.62")	993 mm (39.1")	1024 mm (40.3")	967 mm (38.1")	48	7.0 ms	3.7 ms
MAE4216 Emitter MAR4216NX485 Receiver	1057 mm (41.62")	1146 mm (45.1")	1176 mm (46.3")	1119 mm (44.1")	56	8.1 ms	4.3 ms

¹ Standard 2 m (6.5 ft) cable models are listed. To order the 150 mm (6.5 inch) M/12Euro-style pigtail quick disconnect models, add the suffix "Q" to model number (for example, MAE616Q).

² Worst-case response time is twice the scan time.

³ Scan time for Vehicle Separation scanning configuration.



Emitter/Receiver Models ¹	Array Length (Y)	Housing Length (L1)	Distance Between Bracket Holes		Total Beams	Sensor Scan Time ²	
			L2	L3		Interlaced Scan ³	Straight Scan
MAE4816 Emitter MAR4816NX485 Receiver	1210 mm (47.62")	1298 mm (51.1")	1329 mm (52.3")	1272 mm (50.1")	64	9.2 ms	4.8 ms
MAE6016 Emitter MAR6016NX485 Receiver	1514 mm (59.62")	1603 mm (63.1")	1633 mm (64.3")	1577 mm (62.1")	80	11.5 ms	6.0 ms
MAE7216 Emitter MAR7216NX485 Receiver	1819 mm (71.62")	1908 mm (75.1")	1938 mm (76.3")	1881 mm (74.1")	96	13.7 ms	7.1 ms



WARNING: Not To Be Used for Personnel Protection

Never use this device as a sensing device for personnel protection. Doing so could lead to serious injury or death. This device does not include the self-checking redundant circuitry necessary to allow its use in personnel safety applications. A sensor failure or malfunction can cause either an energized or de-energized sensor output condition.

Emitter and Receiver Wiring

Connect the emitter and receiver cables as shown.

Receiver Output 1: (OUT1) is an open-collector NPN transistor switch rated at 30 V dc max., 150 mA max. It is protected against overload and short circuits.

Receiver Alarm: (ALARM) is an open-collector NPN transistor switch rated at 30 V dc max., 150 mA max. It is protected against overload and short circuits.

Both outputs are current sinking.

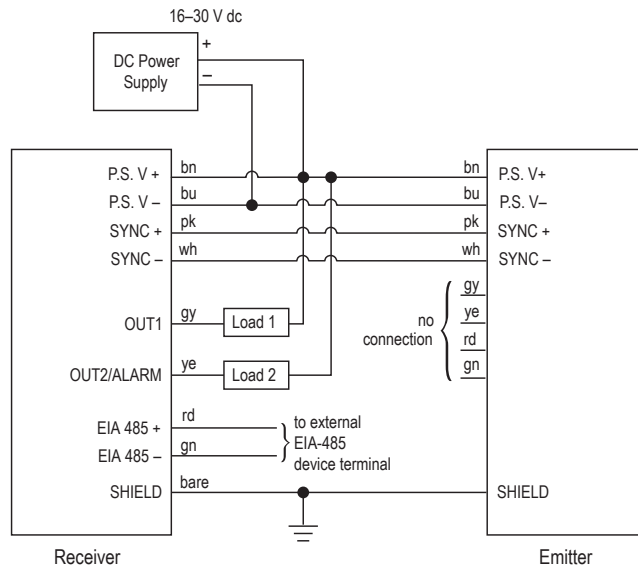

¹ Standard 2 m (6.5 ft) cable models are listed. To order the 150 mm (6.5 inch) M/12Euro-style pigtail quick disconnect models, add the suffix "Q" to model number (for example, MAE616Q).
² Worst-case response time is twice the scan time.
³ Scan time for Vehicle Separation scanning configuration.

Specifications

Supply Voltage and Power

16 to 30 V dc; maximum power 12 watts

Supply Protection Circuitry

Protected against reverse polarity and transient voltages

Discrete Output Configuration

Two discrete outputs: Output 1 and Output 2

Outputs can be configured as either open collector NPN or PNP transistors. For the vehicle separation application, the outputs are factory configured as NPN outputs.

Discrete Output (either NPN or PNP) Ratings

Rated at 30V dc max, 150 mA max load, short circuit protected

OFF-State Leakage Current: < 10 μ A at 30 V dc

ON-State Saturation Voltage: < 1 V at 10 mA, < 1.5 V at 150 mA

Serial Data Outputs

EIA-485 interface

Baud rate 9600, 19.2 K, 38.4 K

8 data bits, 1 start bit, 1 stop bit, no parity

Controller Programming

Via EIA-485 to PC-compatible computer running Windows® 98, NT, ME, XP, 2000 Operating System

Emitter/Receiver Range

Sensors < 1220 mm (4 ft) long: 0.9 to 16.5 m (3 ft to 55 ft)

Sensors \geq 1220 mm (4 ft) long: 0.9 to 13.5 m (3 ft to 45 ft)

Maximum range is specified at the point where 3x excess gain remains.

Minimum Object Sensitivity

Interlaced Mode: 25.4 mm (1.0 in) ⁴

Other Scan Modes: 38.1 mm (1.5 in)

Sensor Scan Time

See table in front page.

Worst-case response time is twice the scan time.

Cable Connections

See hookup diagram above. QD cables available separately.

Emitter and receiver cables may not exceed 80 m (250 ft) each.

Status Indicators

Emitter: Red LED lights for proper operation

Receiver: Green – sensors aligned (> 3x excess gain); Yellow – marginal alignment (1x-3x excess gain); Red – sensors misaligned or beam(s) blocked

Environmental Rating

NEMA 4, 13

IP65

UL Type 1 enclosure

Construction

Aluminum housing with black anodized finish; acrylic lens cover

Operating Conditions

Temperature: -40 °C to +70 °C (-40 °F to +158 °F)

95% maximum relative humidity (non-condensing)

Certifications



Application Notes

The emitter and receiver sync lines (pink and white wires) will be damaged if connected to the power supply.

The receiver EIA-485 interface (red and green wires) will be damaged if connected to the power supply.

Banner Engineering Corp. Limited Warranty

Banner Engineering Corp. warrants its products to be free from defects in material and workmanship for one year following the date of shipment. Banner Engineering Corp. will repair or replace, free of charge, any product of its manufacture which, at the time it is returned to the factory, is found to have been defective during the warranty period. This warranty does not cover damage or liability for misuse, abuse, or the improper application or installation of the Banner product.

THIS LIMITED WARRANTY IS EXCLUSIVE AND IN LIEU OF ALL OTHER WARRANTIES WHETHER EXPRESS OR IMPLIED (INCLUDING, WITHOUT LIMITATION, ANY WARRANTY OF MERCHANTABILITY OR FITNESS FOR A PARTICULAR PURPOSE), AND WHETHER ARISING UNDER COURSE OF PERFORMANCE, COURSE OF DEALING OR TRADE USAGE.

This Warranty is exclusive and limited to repair or, at the discretion of Banner Engineering Corp., replacement. IN NO EVENT SHALL BANNER ENGINEERING CORP. BE LIABLE TO BUYER OR ANY OTHER PERSON OR ENTITY FOR ANY EXTRA COSTS, EXPENSES, LOSSES, LOSS OF PROFITS, OR ANY INCIDENTAL, CONSEQUENTIAL OR SPECIAL DAMAGES RESULTING FROM ANY PRODUCT DEFECT OR FROM THE USE OR INABILITY TO USE THE PRODUCT, WHETHER ARISING IN CONTRACT OR WARRANTY, STATUTE, TORT, STRICT LIABILITY, NEGLIGENCE, OR OTHERWISE.

Banner Engineering Corp. reserves the right to change, modify or improve the design of the product without assuming any obligations or liabilities relating to any product previously manufactured by Banner Engineering Corp.

⁴ Assumes sensing is in middle one-third of scanning range.