

1

2

3

4

5

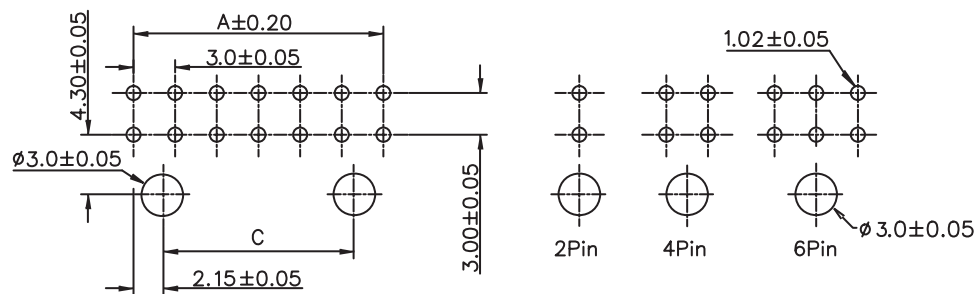

PCB LAYOUT - COMPONENT VIEW

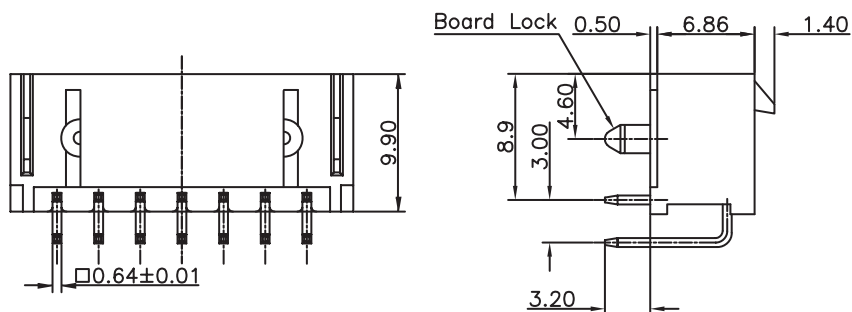
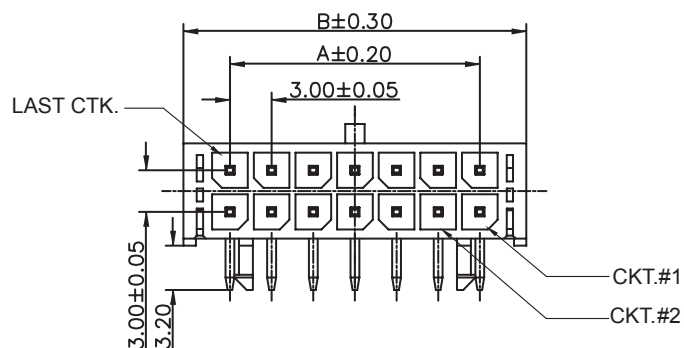

## TECHNICAL CHARACTERISTICS

MATERIAL  
 INSULATOR: LCP  
 FLAMABILITY RATING: UL94-V0  
 COLOR: BLACK  
 CONTACT MATERIAL: COPPER ALLOY  
 CONTACT TYPE: STAMPED  
 CONTACT PLATING: TIN  
 QUALITY CLASS: 25 MATING CYCLES  
 PITCH: 3.00MM

ENVIRONMENTAL  
 OPERATING TEMPERATURE: -40 UP TO 105°C  
 COMPLIANCE: LEAD FREE AND ROHS

ELECTRICAL  
 CURRENT RATING: 5A  
 WORKING VOLTAGE: 250V AC  
 INSULATOR RESISTANCE: >1000 MOHM  
 DIELECTRIC WITHSTANDING VOLTAGE: 1500V AC/MN  
 CONTACT RESISTANCE: 10 mOHM MAX

STANDARD  
 CERTIFIED: E323964

SOLDERING  
 JEDEC LEAD FREE WAVE SOLDERING

PACKAGING  
 TUBE

DIMENSION  
 A = 3.00 x (NB. PIN / 2 - 1)  
 B = 3.00 x (NB. PIN / 2 + 1) + 0.70

NB. PIN	C	NB. PIN	C
2 to 6	-	16	16.68
8	4.68	18	19.68
10	7.68	20	22.68
12	10.68	22	25.68
14	13.68	24	28.68

RoHS Compliant

PROJECTION:

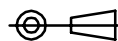

GENERAL TOLERANCE

.X = +/- 0.2

.XX = +/- 0.15



APPROVAL: BBu

UNIT: MM

SCALE:

SHEET: 1/2

DRAW: AS

DESCRIPTION: WR-MPC3 - 3.00MM MALE DUAL ROW RIGHT ANGLE  
 HEADER WITH PLASTIC PEGS  
 WERI PART NO: 662 0xx 210 22

SIZE

A4

REV	DATE	FILE	BY
J	26-SEP-14	DRAWING	AS
I	17-FEB-14	SOLDERING	QL
H	29-JUL-13	DWG & CARAC	QL

1

2

3

4

5

## Cautions and Warnings:

This electronic component is designed and developed with the intention for use in general electronics equipments.

Before incorporating the components into any equipments in the field such as aerospace, aviation, nuclear control, submarine, transportation, (automotive control, train control, ship control), transportation signal, disaster prevention, medical, public information network etc. where higher safety and reliability are especially required or if there is possibility of direct damage or injury to human body, Würth Elektronik must be asked for a written approval.



In addition, even electronic component in general electronic equipments, when used in electrical circuits that require high safety, reliability functions or performance, the sufficient reliability evaluation-check for the safety must be performed before by the user before usage.

A

B

C

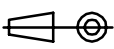
RoHS Compliant

G				PROJECTION: 	GENERAL TOLERANCE .X = +/- 0.2 .XX = +/- 0.15		
F							
E							
D							
C				APPROVAL: JC	UNIT: MM	DESCRIPTION: DISCLAIMER	SIZE <b>A4</b>
B					SCALE:		
A	10-SEP-14	PDF	QL		SHEET: 2/2	WERI PART NO: DISCLAIMER	
REV	DATE	FILE	BY		DRAW: QL		

D