

## 1:10 LOW JITTER UNIVERSAL BUFFER/LEVEL TRANSLATOR WITH 2:1 INPUT MUX AND INDIVIDUAL OE (<1.25 GHz)

### Features

- 10 differential or 20 LVCMOS outputs
- Ultra-low additive jitter: 100 fs rms
- Wide frequency range: 1 MHz to 1.25 GHz
- Any-format input with pin selectable output formats: LVPECL, Low Power LVPECL, LVDS, CML, HCSL, LVCMOS
- 2:1 mux with hot-swappable inputs
- Asynchronous output enable
- Individual output enable
- Low output-output skew: <50 ps
- Low propagation delay variation: <400 ps
- Independent  $V_{DD}$  and  $V_{DDO}$ : 1.8/2.5/3.3 V
- Excellent power supply noise rejection (PSRR)
- Selectable LVCMOS drive strength to tailor jitter and EMI performance
- Small size: 44-QFN (7 mm x 7 mm)
- RoHS compliant, Pb-free
- Industrial temperature range: -40 to +85 °C

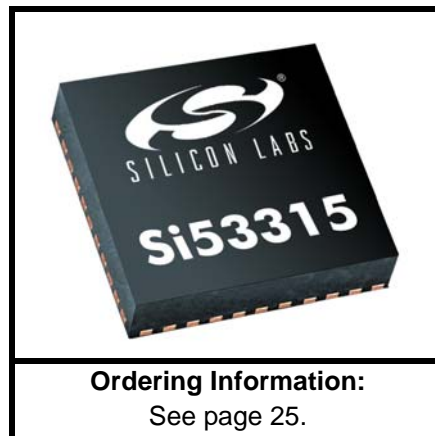

### Applications

- High-speed clock distribution
- Ethernet switch/router
- Optical Transport Network (OTN)
- SONET/SDH
- PCI Express Gen 1/2/3
- Storage
- Telecom
- Industrial
- Servers
- Backplane clock distribution

### Description

The Si53315 is an ultra low jitter ten output differential buffer with pin-selectable output clock signal format and individual OE. The Si53315 features a 2:1 mux, making it ideal for redundant clocking applications. The Si53315 utilizes Silicon Laboratories' advanced CMOS technology to fanout clocks from 1 MHz to 1.25 GHz with guaranteed low additive jitter, low skew, and low propagation delay variability. The Si53315 features minimal cross-talk and provides superior supply noise rejection, simplifying low jitter clock distribution in noisy environments. Independent core and output bank supply pins provide integrated level translation without the need for external circuitry.

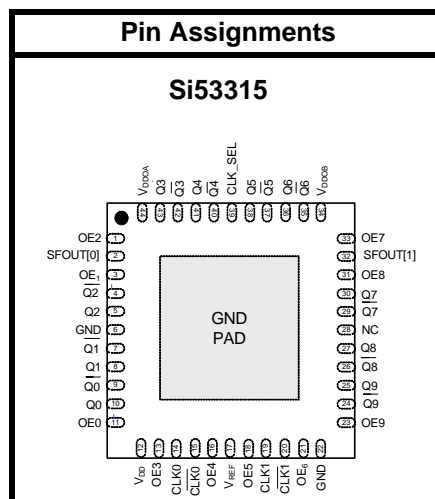

Patents pending

### Functional Block Diagram

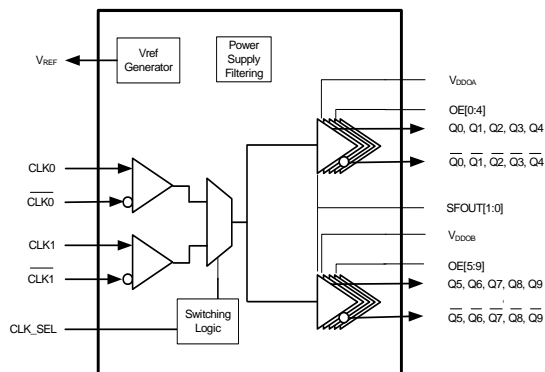

## TABLE OF CONTENTS

---

<u>Section</u>	<u>Page</u>
<b>1. Electrical Specifications</b> .....	<b>3</b>
<b>2. Functional Description</b> .....	<b>10</b>
2.1. Universal, Any-Format Input .....	10
2.2. Input Bias Resistors .....	12
2.3. Universal, Any-Format Output Buffer .....	12
2.4. Input Mux and Output Enable Logic .....	13
2.5. Power Supply ( $V_{DD}$ and $V_{DDOX}$ ) .....	13
2.6. Output Clock Termination Options .....	14
2.7. AC Timing Waveforms .....	17
2.8. Typical Phase Noise Performance .....	18
2.9. Input Mux Noise Isolation .....	19
2.10. Power Supply Noise Rejection .....	20
<b>3. Pin Description: 44-Pin QFN</b> .....	<b>21</b>
<b>4. Ordering Guide</b> .....	<b>25</b>
<b>5. Package Outline</b> .....	<b>26</b>
5.1. 7x7 mm 44-QFN Package Diagram .....	26
<b>6. PCB Land Pattern</b> .....	<b>27</b>
6.1. 7x7 mm 44-QFN Package Land Pattern .....	27
<b>7. Top Marking</b> .....	<b>28</b>
7.1. Si53315 Top Marking .....	28
7.2. Top Marking Explanation .....	28
<b>Contact Information</b> .....	<b>30</b>

## 1. Electrical Specifications

**Table 1. Recommended Operating Conditions**

Parameter	Symbol	Test Condition	Min	Typ	Max	Unit
Ambient Operating Temperature	$T_A$		-40	—	85	°C
Supply Voltage Range*	$V_{DD}$	LVDS, CML, HCSSL, LVCMOS	1.71	1.8	1.89	V
		LVPECL, low power LVPECL, LVDS, CML, HCSSL, LVCMOS	2.38	2.5	2.63	V
			2.97	3.3	3.63	V
Output Buffer Supply Voltage*	$V_{DDO}$	LVDS, CML, HCSSL, LVCMOS	1.71	—	1.89	V
		LVPECL, low power LVPECL, LVDS, CML, HCSSL, LVCMOS	2.38	—	2.63	V
			2.97	—	3.63	V

**\*Note:** Core supply  $V_{DD}$  and output buffer supplies  $V_{DDO}$  are independent.

**Table 2. Input Clock Specifications**

( $V_{DD} = 1.8\text{ V} \pm 5\%$ ,  $2.5\text{ V} \pm 5\%$ , or  $3.3\text{ V} \pm 10\%$ ,  $T_A = -40$  to  $85\text{ }^\circ\text{C}$ )

Parameter	Symbol	Test Condition	Min	Typ	Max	Unit
Differential Input Common Mode Voltage	$V_{CM}$	$V_{DD} = 2.5\text{ V} \pm 5\%$ , $3.3\text{ V} \pm 10\%$	0.05	—	—	V
Input Swing (single-ended, peak-to-peak)	$V_{IN}$		0.1	—	1.1	V
Input Voltage High	$V_{IH}$		$V_{DD} \times 0.7$	—	—	V
Input Voltage Low	$V_{IL}$		—	—	$V_{DD} \times 0.3$	V
Input Capacitance	$C_{IN}$		—	5	—	pF

**Table 3. DC Common Characteristics**

( $V_{DD} = 1.8\text{ V} \pm 5\%$ ,  $2.5\text{ V} \pm 5\%$ , or  $3.3\text{ V} \pm 10\%$ ,  $T_A = -40\text{ to }85\text{ }^\circ\text{C}$ )

Parameter	Symbol	Test Condition	Min	Typ	Max	Unit
Supply Current	$I_{DD}$		—	TBD	100	mA
Output Buffer Supply Current (Per Clock Output) @100 MHz	$I_{DDOX}$	LVPECL (3.3 V)	—	35	—	mA
		Low Power LVPECL (3.3 V)	—	30	—	mA
		LVDS (3.3 V)	—	20	—	mA
		CML (3.3 V)	—	30	—	mA
		HCSL, 100 MHz, 2 pF load (3.3 V)	—	35	—	mA
		CMOS (1.8 V, SFOUT = Open/0), per output, $C_L = 5\text{ pF}$ , 200 MHz	—	5	—	mA
		CMOS (2.5 V, SFOUT = Open/0), per output, $C_L = 5\text{ pF}$ , 200 MHz	—	8	—	mA
Leakage Current	$I_L$	Input leakage at all inputs except CLKIN, $V_{IN} = 0\text{ V}$	—	—	TBD	$\mu\text{A}$
		Input leakage at CLKIN $V_{IN} = 0\text{ V}$	—	—	TBD	$\mu\text{A}$
Voltage Reference	$V_{REF}$	$V_{REF}$ pin	—	$V_{DD}/2$	—	V
Input High Voltage	$V_{IH}$	SFOUTX, DIVX 3-level input pins	$0.85 \times V_{DD}$	—	—	V
Input Mid Voltage	$V_{IM}$	SFOUTX, DIVX 3-level input pins	$0.45 \times V_{DD}$	$0.5 \times V_{DD}$	$0.55 \times V_{DD}$	V
Input Low Voltage	$V_{IL}$	SFOUTX, DIVXpin 3-level input pins	—	—	$0.15 \times V_{DD}$	V
Internal Pull-down Resistor	$R_{DOWN}$	CLK_SEL, DIVA, DIVB, SFOUTA[1], SFOUTB[1]	—	25	—	k $\Omega$
Internal Pull-up Resistor	$R_{UP}$	SFOUTA[1], SFOUTB[1], DIVA, DIVB, OEX, OEX	—	25	—	k $\Omega$

**Table 4. DC Characteristics—LVPECL and Low Power LVPECL** $(V_{DD} = 2.5\text{ V} \pm 5\%$ , or  $3.3\text{ V} \pm 10\%$ ,  $T_A = -40$  to  $85\text{ }^\circ\text{C}$ )

Parameter	Symbol	Test Condition	Min	Typ	Max	Unit
Output Voltage High	$V_{OH}$	$R_L = 50\ \Omega$ to $V_{DDOX} - 2\text{ V}$	$V_{DDOX} - 1.145$	—	$V_{DDOX} - 0.895$	V
Output Voltage Low	$V_{OL}$	$R_L = 50\ \Omega$ to $V_{DDOX} - 2\text{ V}$	$V_{DDOX} - 1.945$	—	$V_{DDOX} - 1.695$	V
Output DC Common Mode Voltage	$V_{COM}$		$V_{DDOX} - 1.895$	—	$V_{DDOX} - 1.425$	V
Single-Ended Output Swing	$V_{SE}$	Terminate unused outputs to $R_L = 50\ \Omega$ to $V_{DDOX} - 2\text{ V}$	0.25	0.60	0.85	V

**Table 5. DC Characteristics—CML** $(V_{DD} = 1.8\text{ V} \pm 5\%$ ,  $2.5\text{ V} \pm 5\%$ , or  $3.3\text{ V} \pm 10\%$ ,  $T_A = -40$  to  $85\text{ }^\circ\text{C}$ )

Parameter	Symbol	Test Condition	Min	Typ	Max	Unit
Single-Ended Output Swing	$V_{SE}$	Terminated as shown in Figure 6 (CML termination).	300	400	500	mV

**Table 6. DC Characteristics—LVDS** $(V_{DD} = 1.8\text{ V} \pm 5\%$ ,  $2.5\text{ V} \pm 5\%$ , or  $3.3\text{ V} \pm 10\%$ ,  $T_A = -40$  to  $85\text{ }^\circ\text{C}$ )

Parameter	Symbol	Test Condition	Min	Typ	Max	Unit
Single-Ended Output Swing	$V_{SE}$	$R_L = 100\ \Omega$ across $Q_N$ and $\overline{Q}_N$	247	—	454	mV
Output Common Mode Voltage ( $V_{DDO} = 2.5\text{ V}$ or $3.3\text{ V}$ )	$V_{COM1}$	$V_{DDOX} = 2.38$ to $2.63\text{ V}$ , $2.97$ to $3.63\text{ V}$ , $R_L = 100\ \Omega$ across $Q_N$ and $\overline{Q}_N$	1.10	1.25	1.35	V
Output Common Mode Voltage ( $V_{DDO} = 1.8\text{ V}$ )	$V_{COM2}$	$V_{DDOX} = 1.71$ to $1.89\text{ V}$ , $R_L = 100\ \Omega$ across $Q_N$ and $\overline{Q}_N$	0.85	0.97	1.10	V

**Table 7. DC Characteristics—LVCMOS**

( $V_{DD} = 1.8\text{ V} \pm 5\%$ ,  $2.5\text{ V} \pm 5\%$ , or  $3.3\text{ V} \pm 10\%$ ,  $T_A = -40\text{ to }85\text{ }^\circ\text{C}$ )

Parameter	Symbol	Test Condition	Min	Typ	Max	Unit
Output Voltage High*	$V_{OH}$		$0.8 \times V_{DDOX}$	—	—	V
Output Voltage Low*	$V_{OL}$		—	—	$0.2 \times V_{DDOX}$	V

\*Note:  $I_{OH}$  and  $I_{OL}$  per the Output Signal Format Table for specific  $V_{DDOX}$  and SFOUTX settings.

**Table 8. DC Characteristics—HCSL**

( $V_{DD} = 1.8\text{ V} \pm 5\%$ ,  $2.5\text{ V} \pm 5\%$ , or  $3.3\text{ V} \pm 10\%$ ,  $T_A = -40\text{ to }85\text{ }^\circ\text{C}$ )

Parameter	Symbol	Test Condition	Min	Typ	Max	Unit
Output Voltage High	$V_{OH}$	$R_L = 50\ \Omega$ to GND	550	700	850	mV
Output Voltage Low	$V_{OL}$	$R_L = 50\ \Omega$ to GND	-150	0	150	mV
Single-Ended Output Swing	$V_{SE}$	$R_L = 50\ \Omega$ to GND	—	700	—	mV
Crossing Voltage	$V_C$	$R_L = 50\ \Omega$ to GND	250	350	550	mV

**Table 9. AC Characteristics**(V<sub>DD</sub> = 1.8 V ± 5%, 2.5 V ± 5%, or 3.3 V ± 10%, T<sub>A</sub> = -40 to 85 °C)

Parameter	Symbol	Test Condition	Min	Typ	Max	Unit
Frequency	F	LVPECL, low power LVPECL, LVDS, CML, HCSL	1	—	1250	MHz
		LVC MOS	1	—	200	MHz
Duty Cycle <b>Note:</b> 50% input duty cycle.	D <sub>C</sub>	200 MHz, 50 Ω to V <sub>DD</sub> /2, 20/80% T <sub>R</sub> /T <sub>F</sub> < 10% of period (LVC MOS)	TBD	TBD	TBD	%
		20/80% T <sub>R</sub> /T <sub>F</sub> < 10% of period (Differential)	48	50	52	%
Minimum Input Clock Slew Rate <sup>1</sup>	SR	Required to meet prop delay and additive jitter specifications (20–80%)	0.75	—	—	V/ns
Output Rise/Fall Time	T <sub>R</sub> /T <sub>F</sub>	LVPECL, LVDS, CML, HCSL, 20/80%			350	ps
		200 MHz, 50 Ω, 20/80%, 2 pF load (LVC MOS)	TBD	TBD	750	ps
Minimum Input Pulse Width	T <sub>W</sub>		500	—	—	ps
Additive Jitter (Differential Clock Input)	J	V <sub>DD</sub> = 2.5/3.3 V, LVPECL/LVDS, F = 725 MHz, 0.75 V/ns input slew rate	—	60	80	fs
Propagation Delay	T <sub>PLH</sub> , T <sub>PHL</sub>	Low to high, high to low Single-ended	TBD	—	TBD	ns
		Low to high, high to low Differential	TBD	—	TBD	ns
Output Enable Time <sup>2</sup>	T <sub>EN</sub>	F = 1 MHz	—	2	—	μs
		F = 100 MHz	—	60	—	ns
		F = 725 MHz	—	50	—	ns
Output Disable Time <sup>2</sup>	T <sub>DIS</sub>	F = 1 MHz	—	2	—	μs
		F = 100 MHz	—	25	—	ns
		F = 725 MHz	—	15	—	ns

**Notes:**

1. For clock division applications, a minimum input clock slew rate of 30 mV/ns is required.
2. See Figure 4.
3. Defined as skew between outputs on different devices operating at the same supply voltages, temperatures, and equal load conditions. Using the same type of inputs on each device, the outputs are measured at the differential cross points.
4. Measured for 156.25 MHz carrier frequency. Sine-wave noise added to V<sub>DDOX</sub> (1.8 V = 50 mV<sub>PP</sub>, 2.5/3.3 V = 100 mV<sub>PP</sub>) and noise spur amplitude measured. See AN491 for further details.

**Table 9. AC Characteristics (Continued)**

( $V_{DD} = 1.8\text{ V} \pm 5\%$ ,  $2.5\text{ V} \pm 5\%$ , or  $3.3\text{ V} \pm 10\%$ ,  $T_A = -40\text{ to }85\text{ }^\circ\text{C}$ )

Parameter	Symbol	Test Condition	Min	Typ	Max	Unit
Output to Output Skew	$T_{SK}$	Identical Configuration, Single-ended ( $Q_N$ to $Q_M$ )	—	—	100	ps
		Identical Configuration, Differential ( $Q_N$ to $Q_M$ )	—	—	50	ps
Part to Part Skew <sup>3</sup>	$T_{PS}$	Identical configuration	—	50	—	ps
Power Supply Noise Rejection <sup>4</sup>	PSRR	10 kHz sinusoidal noise	—	-90	—	dBc
		100 kHz sinusoidal noise	—	-90	—	dBc
		500 kHz sinusoidal noise	—	-80	—	dBc
		1 MHz sinusoidal noise	—	-70	—	dBc

**Notes:**

1. For clock division applications, a minimum input clock slew rate of 30 mV/ns is required.
2. See Figure 4.
3. Defined as skew between outputs on different devices operating at the same supply voltages, temperatures, and equal load conditions. Using the same type of inputs on each device, the outputs are measured at the differential cross points.
4. Measured for 156.25 MHz carrier frequency. Sine-wave noise added to  $V_{DDOX}$  ( $1.8\text{ V} = 50\text{ mV}_{PP}$ ,  $2.5/3.3\text{ V} = 100\text{ mV}_{PP}$ ) and noise spur amplitude measured. See AN491 for further details.

Table 10. Thermal Conditions

Parameter	Symbol	Test Condition	Value	Unit
Thermal Resistance, Junction to Ambient	$\theta_{JA}$	Still air	46.2	°C/W
Thermal Resistance, Junction to Case	$\theta_{JC}$	Still air	27.1	°C/W

Table 11. Absolute Maximum Ratings

Parameter	Symbol	Test Condition	Min	Typ	Max	Unit
Storage Temperature	$T_S$		-55	—	150	°C
Supply Voltage	$V_{DD}$		-0.5	—	3.8	V
Input Voltage	$V_{IN}$		-0.5	—	$V_{DD} + 0.3$	V
Output Voltage	$V_{OUT}$		—	—	$V_{DD} + 0.3$	V
ESD Sensitivity	HBM	HBM, 100 pF, 1.5 k $\Omega$	2000	—	—	V
ESD Sensitivity	CDM		500	—	—	V
Peak Soldering Reflow Temperature	$T_{PEAK}$	Pb-Free; Solder reflow profile per JEDEC J-STD-020	—	—	260	°C
Maximum Junction Temperature	$T_J$		—	—	125	°C
<b>Note:</b> Stresses beyond those listed in this table may cause permanent damage to the device. Functional operation specification compliance is not implied at these conditions. Exposure to maximum rating conditions for extended periods may affect device reliability.						

## 2. Functional Description

The Si53315 is a low jitter, low skew 1:10 differential buffer with an integrated 2:1 input mux and individual OE control. The device has a universal input that accepts most common differential or LVCMOS input signals. A clock select pin is used to select the active input clock. The selected clock input is routed to two independent banks of outputs. Each output bank features control pins to select signal format and LVCMOS drive strength settings. In addition, each clock output has an independent OE pin for individual clock enable/disable.

### 2.1. Universal, Any-Format Input

The Si53315 has a universal input stage that enables simple interfacing to a wide variety of clock formats, including LVPECL, LVCMOS, LVDS, HCSL, and CML. Tables 12 and 13 summarize the various input ac- and dc-coupling options supported by the device. Figures 1 and 2 show the recommended input clock termination options.

**Table 12. LVPECL, LVCMOS, and LVDS**

	LVPECL		LVCMOS		LVDS	
	AC-Couple	DC-Couple	AC-Couple	DC-Couple	AC-Couple	DC-Couple
1.8 V	N/A	N/A	No	Yes	Yes	No
2.5/3.3 V	Yes	Yes	No	Yes	Yes	Yes

**Table 13. HCSL and CML**

	HCSL		CML	
	AC-Couple	DC-Couple	AC-Couple	DC-Couple
1.8 V	No	No	Yes	No
2.5/3.3 V	No	Yes (3.3 V)	Yes	No

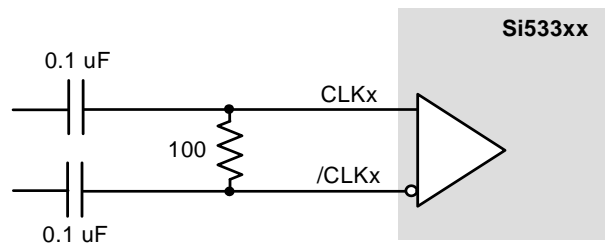

**Figure 1. Differential LVPECL, LVDS, CML AC-Coupled Input Termination**

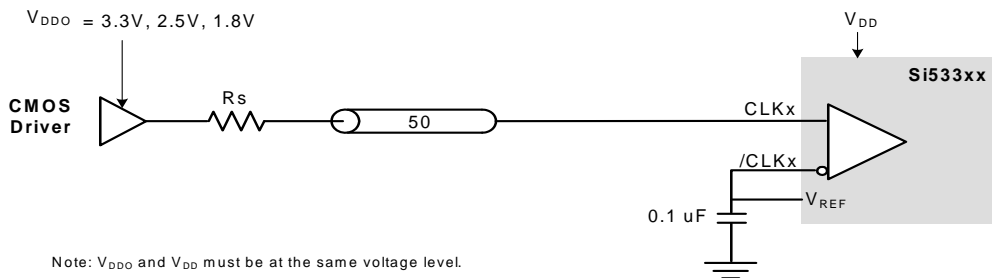

**Figure 2. LVCMOS DC-Coupled Input Termination**

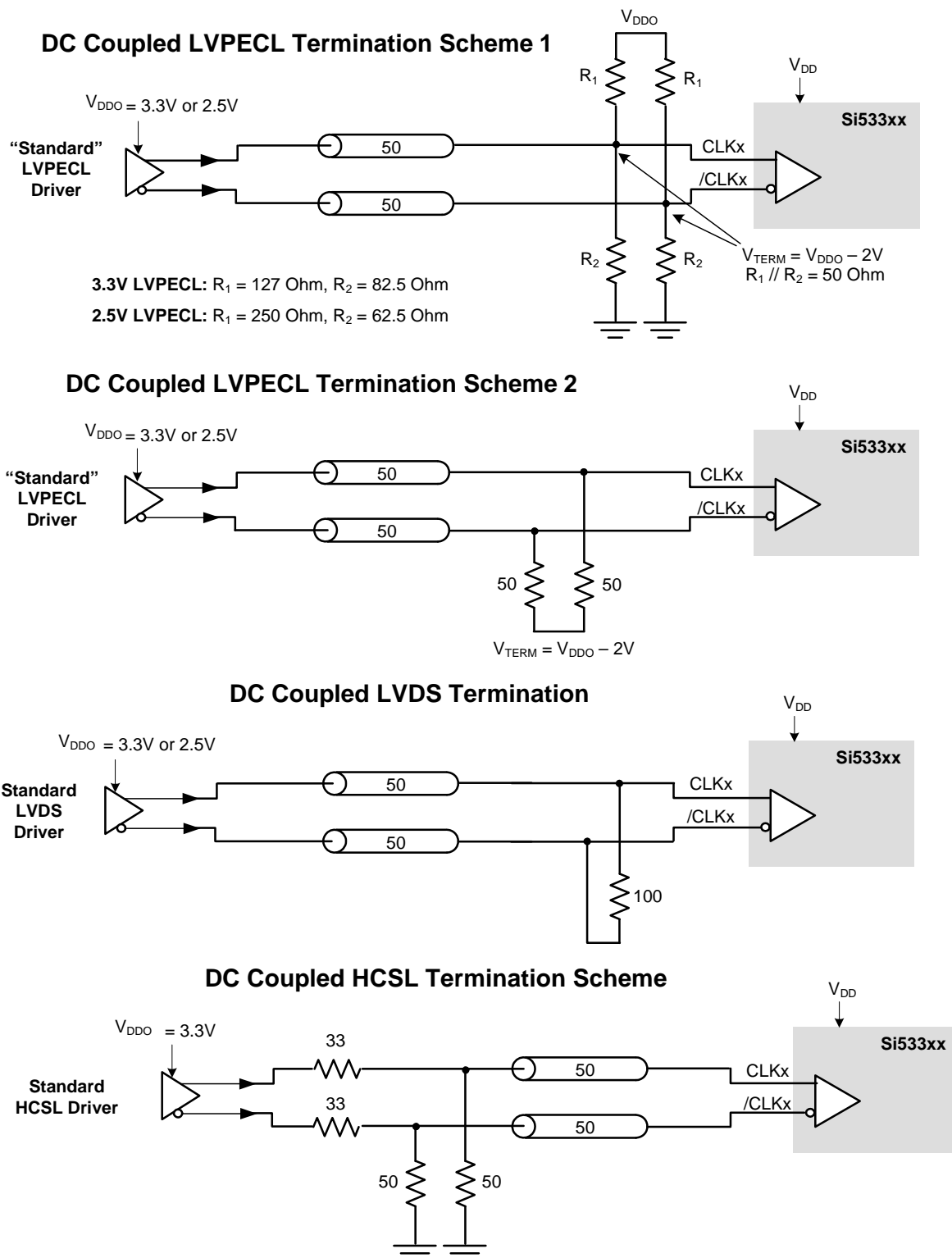

Note: 33 Ohm series termination is optional depending on the location of the receiver.

**Figure 3. Differential DC-Coupled Input Terminations**

## 2.2. Input Bias Resistors

Internal bias resistors ensure a differential output low condition in the event that the clock inputs are not connected. The noninverting input is biased with a 18.75 kΩ pullup to V<sub>DD</sub> and a 75 kΩ pullup to V<sub>DD</sub>. The inverting input is biased with a 75 kΩ pullup to V<sub>DD</sub> and a 18.75 kΩ pullup to GND.

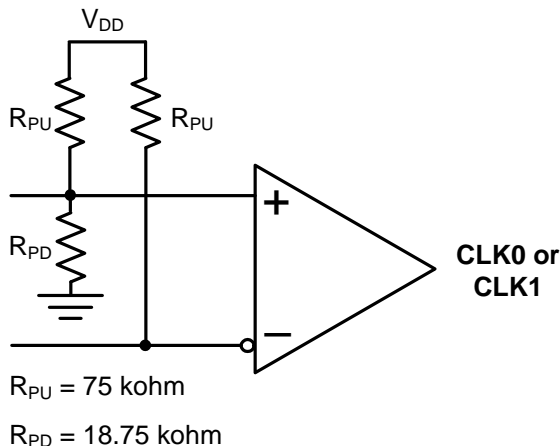

**Figure 4. Input Bias Resistors**

## 2.3. Universal, Any-Format Output Buffer

The Si53315 has highly flexible output drivers that support a wide range of clock signal formats, including LVPECL, low power LVPECL, LVDS, CML, HCSL, and LVCMOS. SFOUT[0] and SFOUT[1] are 3-level inputs that can be pin-strapped to select the clock signal formats for all of the outputs, Q0 through Q9. This feature enables the device to be used for format/level translation in addition to clock distribution, minimizing the number of unique buffer part numbers required in a typical application and simplifying design reuse. For EMI reduction applications, four LVCMOS drive strength options are available for each V<sub>DDO</sub> setting.

**Table 14. Output Signal Format Selection**

SFOUT[1]	SFOUT[0]	V <sub>DDOX</sub> = 3.3 V	V <sub>DDOX</sub> = 2.5 V	V <sub>DDOX</sub> = 1.8 V
Open*	Open*	LVPECL	LVPECL	N/A
0	0	LVDS	LVDS	LVDS
0	1	LVCMOS, 24 mA drive	LVCMOS, 18 mA drive	LVCMOS, 12 mA drive
1	0	LVCMOS, 18 mA drive	LVCMOS, 12 mA drive	LVCMOS, 9 mA drive
1	1	LVCMOS, 12 mA drive	LVCMOS, 9 mA drive	LVCMOS, 6 mA drive
Open*	0	LVCMOS, 6 mA drive	LVCMOS, 4 mA drive	LVCMOS, 2 mA drive
Open*	1	LVPECL Low power	LVPECL Low power	N/A
0	Open*	CML	CML	CML
1	Open*	HCSL	HCSL	HCSL

\*Note: SFOUT[1:0] are 3-level input pins. Tie low for “0” setting. Tie high for “1” setting. When left open, the pin floats to V<sub>DD</sub>/2.

## 2.4. Input Mux and Output Enable Logic

The Si53315 provides two clock inputs for applications that need to select between one of two clock sources. The CLK\_SEL pin selects the active clock input. The table below summarizes the input and output clock based on the input mux and output enable pin settings.

**Table 15. Input Mux and Output Enable Logic**

CLK_SEL	CLK0	CLK1	OE <sup>1</sup>	Q <sup>2</sup>
L	L	X	H	L
L	H	X	H	H
H	X	L	H	L
H	X	H	H	H
X	X	X	L	L <sup>3</sup>

**Notes:**

1. Output enable active high
2. On the next negative transition of CLK0 or CLK1.
3. Single-end: Q=low,  $\overline{Q}$ =high  
Differential: Q=low,  $\overline{Q}$ =high

## 2.5. Power Supply ( $V_{DD}$ and $V_{DDOX}$ )

The device includes separate core ( $V_{DD}$ ) and output driver supplies ( $V_{DDOX}$ ). This feature allows the core to operate at a lower voltage than  $V_{DDO}$ , reducing current consumption in mixed supply applications. The core  $V_{DD}$  supports 3.3, 2.5, or 1.8 V. Each output bank has its own  $V_{DDOX}$  supply, supporting 3.3, 2.5, or 1.8 V.

## 2.6. Output Clock Termination Options

The recommended output clock termination options are shown below. Unused output clocks should be left floating.

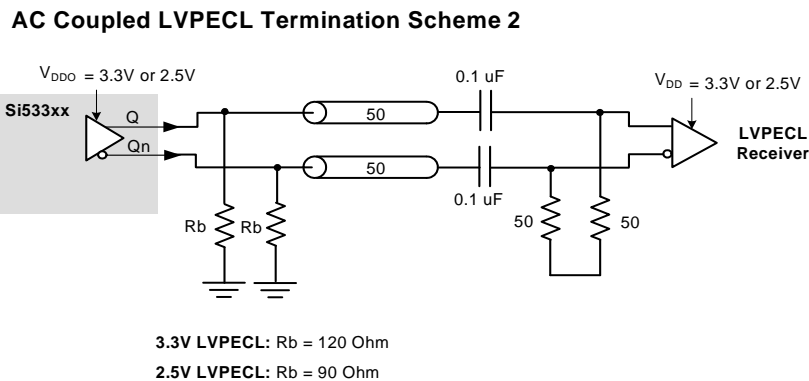
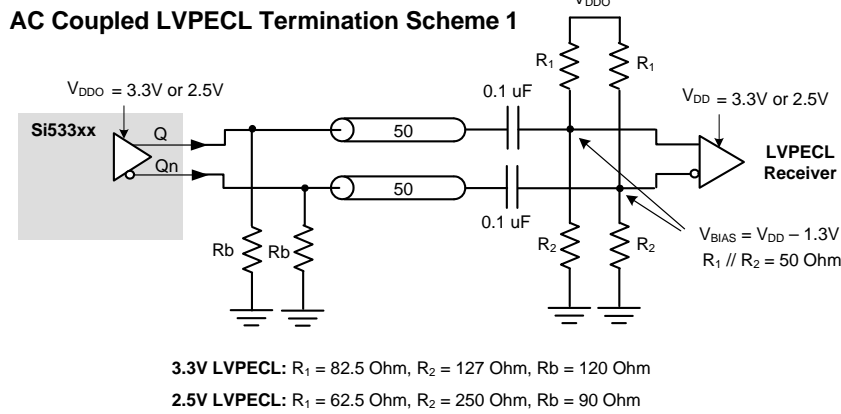
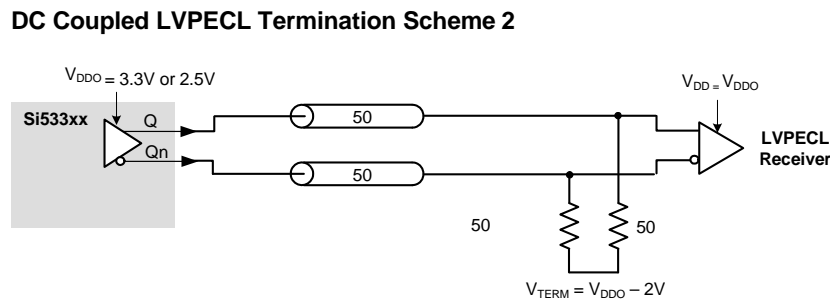
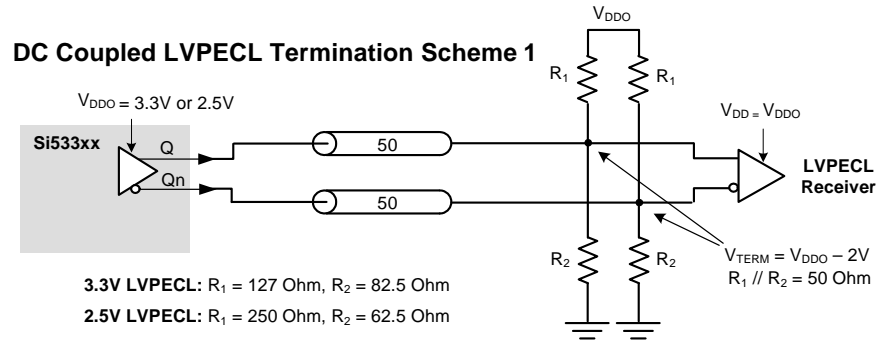

**Figure 5. LVPECL Output Termination**

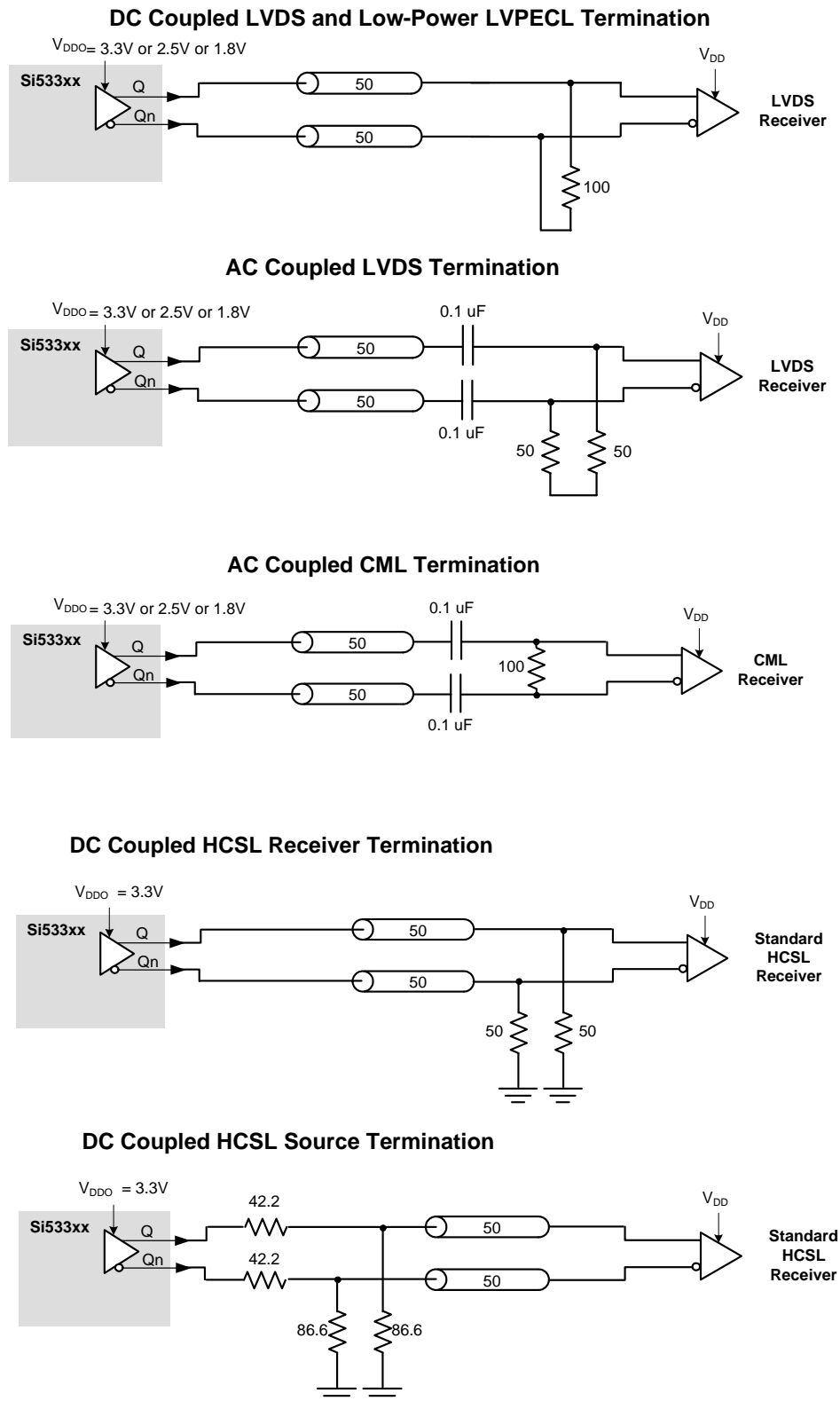
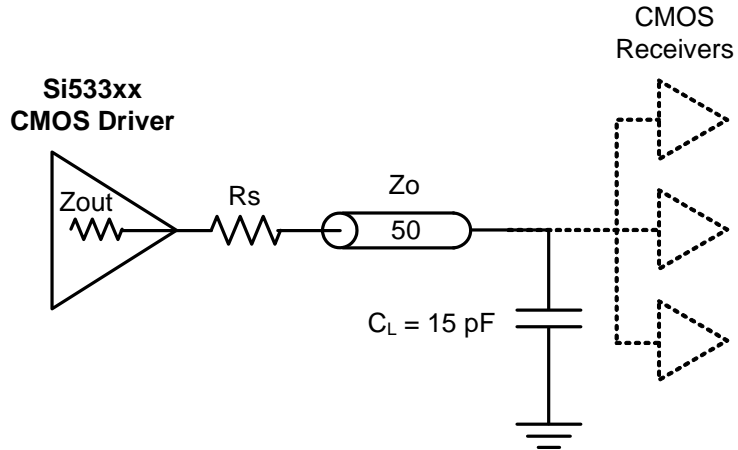

Figure 6. LVDS, CML, and HCSSL Output Termination



**Figure 7. LVC MOS Output Termination**

**Table 16. Recommended LVC MOS  $R_S$  Series Termination**

SFOUT[1]	SFOUT[0]	$R_S$ (ohms)		
		3.3 V	2.5 V	1.8 V
0	1	33	33	33
1	0	33	33	33
1	1	0	0	0
Open	0	0	0	0

## 2.7. AC Timing Waveforms

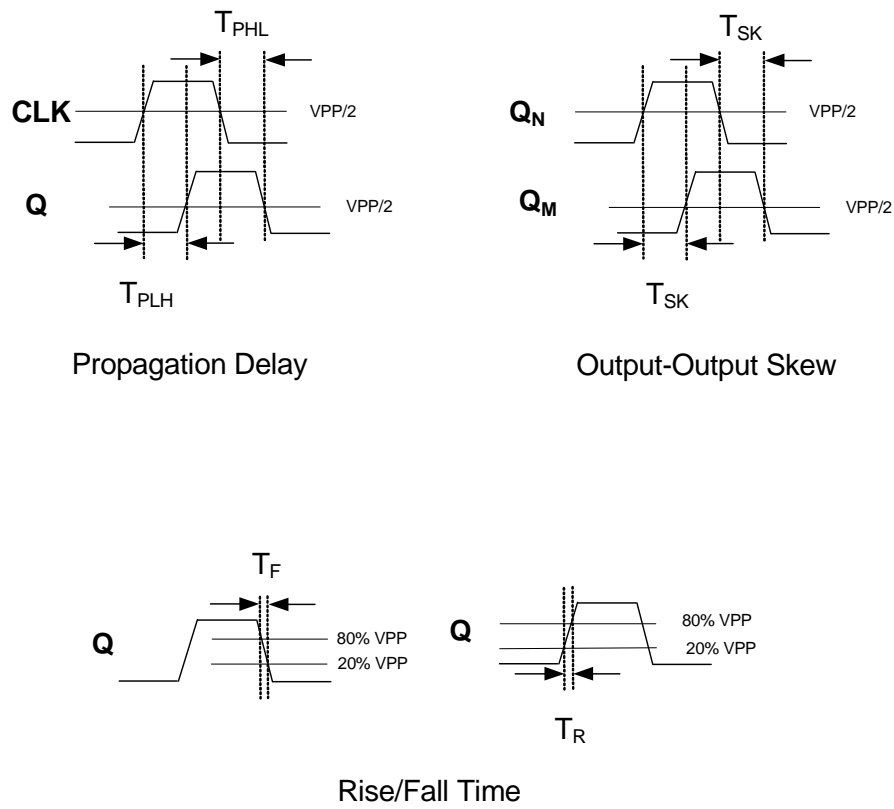
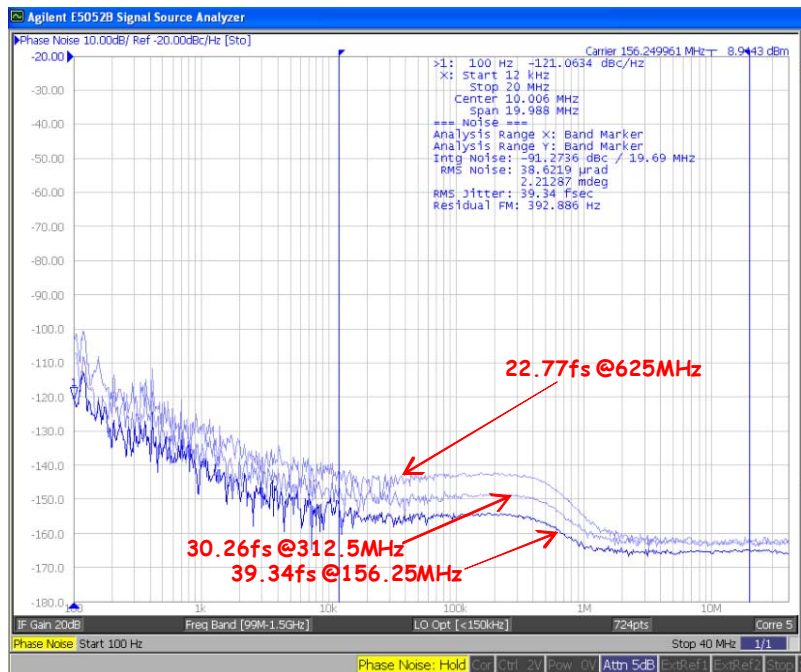
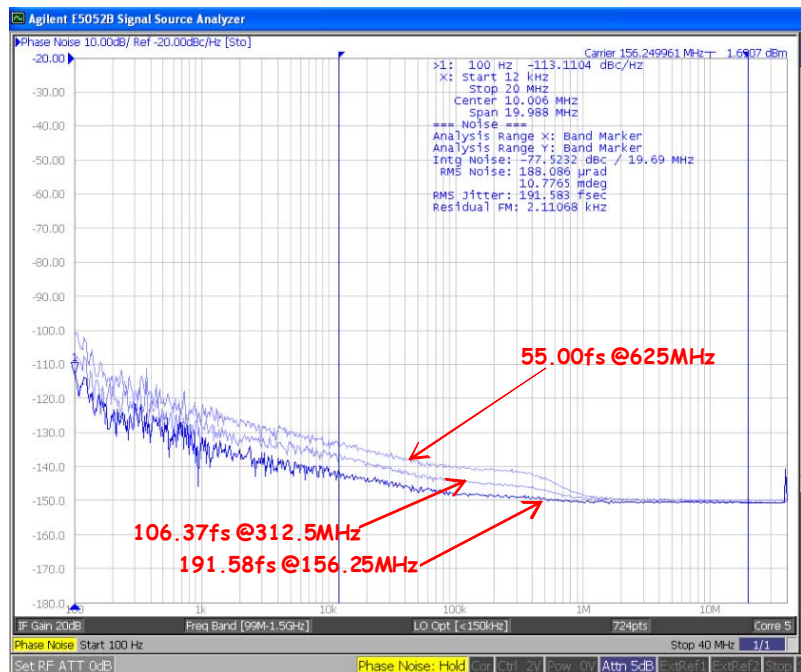

Figure 8. AC Waveforms

## 2.8. Typical Phase Noise Performance



**Source Jitter**



**Total Jitter**

**Figure 9. Si53315 Phase Noise**

**Note:** Measured single-endedly.

Table 17. Si53315 Additive Jitter

Frequency (MHz)	Source Jitter (fs)	Total Jitter (fs)	Additive Jitter (fs)
156.25	39.34	191.58	187.50
312.5	30.26	106.37	101.98
625	22.77	55.00	50.07

## 2.9. Input Mux Noise Isolation

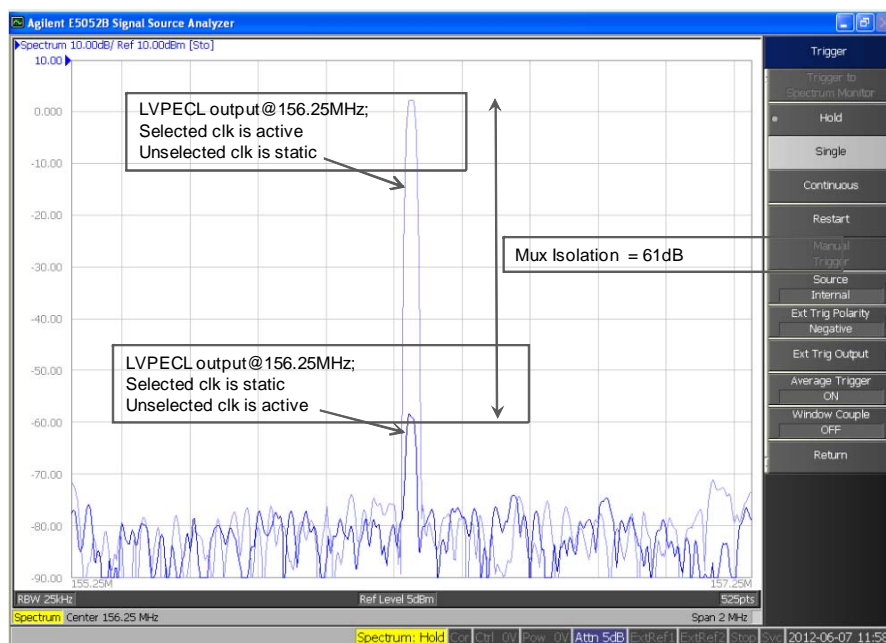

Figure 10. Input Mux Noise Isolation

## 2.10. Power Supply Noise Rejection

The device supports on-chip supply voltage regulation to reject noise present on the power supply, simplifying low jitter operation in real-world environments. This feature enables robust operation alongside FPGAs, ASICs and SoCs and may reduce board-level filtering requirements. For more information, see AN491: Power Supply Rejection for Low Jitter Clocks.

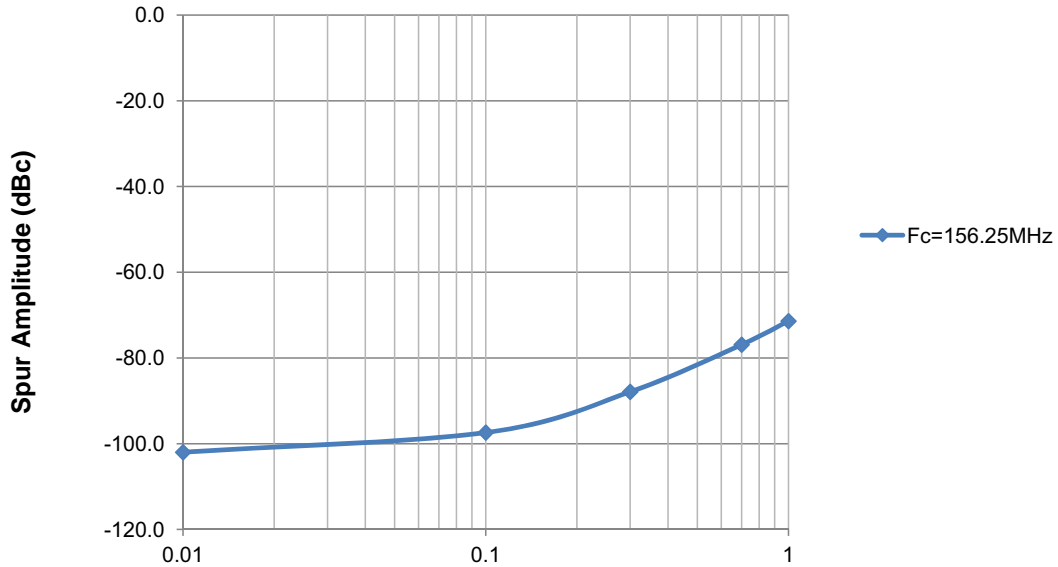

Figure 11. Power Supply Noise Rejection (100 mVpp Sinusoidal Power Supply Noise Applied)

## 3. Pin Description: 44-Pin QFN

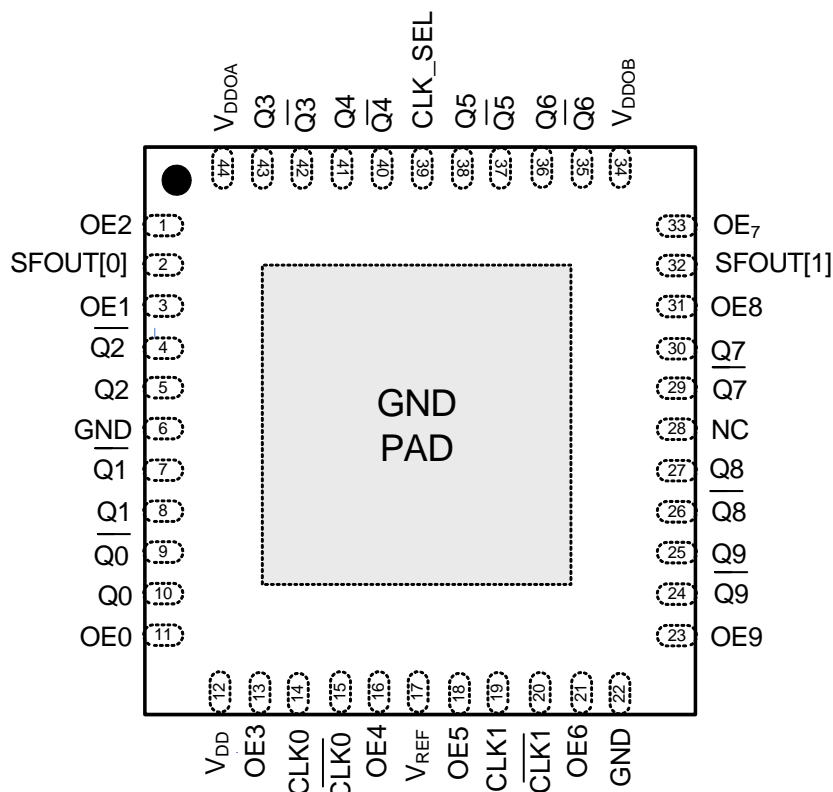

Table 18. Pin Description

Pin #	Name	Description
1	OE2	Output enable—Output 2 When OE = high, the Q2 is enabled. When OE = low, Q is held low, and $\bar{Q}$ is held high for differential formats. For LVCMOS, both Q and $\bar{Q}$ are held low when OE is set low. OE2 contains an internal pull-up resistor.
2	SFOUT[0]	Output signal format control pin [0] Three-level input control. Internally biased at $V_{DD}/2$ . Can be left floating or tied to ground or $V_{DD}$ .
3	OE1	Output enable—Output 1 When OE = high, the Q1 is enabled. When OE = low, Q is held low, and $\bar{Q}$ is held high for differential formats. For LVCMOS, both Q and $\bar{Q}$ are held low when OE is set low. OE1 contains an internal pull-up resistor.
4	$\bar{Q}2$	Output clock 2 (complement)
5	Q2	Output clock 2
6	GND	Ground
7	$\bar{Q}1$	Output clock 1 (complement)

Table 18. Pin Description (Continued)

8	Q1	Output clock 1
9	$\overline{Q0}$	Output clock 0 (complement)
10	Q0	Output clock 0
11	OE0	Output enable—Output 0 When OE = high, the Q0 is enabled. When OE = low, Q is held low, and $\overline{Q}$ is held high for differential formats. For LVCMOS, both Q and $\overline{Q}$ are held low when OE is set low. OE0 contains an internal pull-up resistor.
12	V <sub>DD</sub>	Core voltage supply Bypass with 1.0 $\mu$ F capacitor and place close to the V <sub>DD</sub> pin as possible
13	OE3	Output Enable 3 When OE = high, the Q3 is enabled. When OE = low, Q is held low, and $\overline{Q}$ is held high for differential formats. For LVCMOS, both Q and $\overline{Q}$ are held low when OE is set low. OE3 contains an internal pull-up resistor.
14	CLK0	Input clock 0
15	$\overline{CLK0}$	Input clock 0 (complement) When CLK0 is driven by a single-ended input, connect V <sub>REF</sub> to $\overline{CLK0}$ . $\overline{CLK0}$ contains an internal pull-up resistor.
16	OE4	Output Enable 4 When OE = high, Q4 is enabled. When OE = low, Q is held low, and $\overline{Q}$ is held high for differential formats. For LVCMOS, both Q and $\overline{Q}$ are held low when OE is set low. OE4 contains an internal pull-up resistor.
17	V <sub>REF</sub>	Input reference voltage When driven by a LVCMOS clock input, connect the unused clock input to V <sub>REF</sub> and a 0.1 $\mu$ F cap to ground. When driven by a differential clock, do not connect the V <sub>REF</sub> pin.
18	OE5	Output Enable 5 When OE = high, Q5 is enabled. When OE = low, Q is held low, and $\overline{Q}$ is held high for differential formats. For LVCMOS, both Q and $\overline{Q}$ are held low when OE is set low. OE5 contains an internal pull-up resistor.
19	CLK1	Input clock 1

Table 18. Pin Description (Continued)

20	$\overline{\text{CLK1}}$	Input clock 1 (complement) When CLK1 is driven by a single-ended input, connect $V_{\text{REF}}$ to $\overline{\text{CLK1}}$ . CLK1 contains an internal pull-up resistor
21	OE6	Output Enable 6 When OE = high, Q6 is enabled. When OE = low, Q is held low, and $\overline{Q}$ is held high for differential formats. For LVCMOS, both Q and $\overline{Q}$ are held low when OE is set low. OE6 contains an internal pull-up resistor.
22	GND	Ground
23	OE9	Output Enable 9 When OE = high, the Output 9 outputs are enabled. When OE = low, Q is held low, and $\overline{Q}$ is held high for differential formats. For LVCMOS, both Q and $\overline{Q}$ are held low when OE is set low. OE9 contains an internal pull-up resistor.
24	$\overline{Q9}$	Output clock 9 (complement)
25	Q9	Output clock 9
26	$\overline{Q8}$	Output clock 8 (complement)
27	Q8	Output clock 8
28	NC	No Connect
29	$\overline{Q7}$	Output clock 7 (complement)
30	Q7	Output clock 7
31	OE8	Output Enable 8 When OE = high, Q8 is enabled. When OE = low, Q is held low, and $\overline{Q}$ is held high for differential formats. For LVCMOS, both Q and $\overline{Q}$ are held low when OE is set low. OE8 contains an internal pull-up resistor.
32	SFOUT[1]	Output signal format control pin [1] Three-level input control. Internally biased at $V_{\text{DD}}/2$ . Can be left floating or tied to ground or $V_{\text{DD}}$ .
33	OE7	Output Enable 7 When OE = high, Q7 is enabled. When OE = low, Q is held low, and $\overline{Q}$ is held high for differential formats. For LVCMOS, both Q and $\overline{Q}$ are held low when OE is set low. OE7 contains an internal pull-up resistor.
34	$V_{\text{DDOB}}$	Output voltage supply – Bank B (Outputs Q5 through Q9) Bypass with 1.0 $\mu\text{F}$ capacitor and place as close to $V_{\text{DDOB}}$ pin as possible.
35	$\overline{Q6}$	Output clock 6 (complement)

**Table 18. Pin Description (Continued)**

36	Q6	Output clock 6
37	$\overline{Q5}$	Output clock 5 (complement)
38	Q5	Output clock 5
39	CLK_SEL	MUX input select pin (LVCMOS) When CLK_SEL is high, CLK1 is selected When CLK_SEL is low, CLK0 is selected CLK_SEL contains an internal pull-down resistor
40	$\overline{Q4}$	Output clock 4 (complement)
41	Q4	Output clock 4
42	$\overline{Q3}$	Output clock 3 (complement)
43	Q3	Output clock 3
44	V <sub>DDOA</sub>	Output voltage supply – Bank A (Outputs Q0 to Q4) Bypass with 1.0 $\mu$ F capacitor and place as close to V <sub>DDOA</sub> pin as possible.
GND Pad	GND	Ground Pad Power supply ground and thermal relief

## 4. Ordering Guide

Part Number	Package	PB-Free, ROHS-6	Temperature
Si53315-B-GM	44-QFN	Yes	-40 to 85 °C

## 5. Package Outline

### 5.1. 7x7 mm 44-QFN Package Diagram

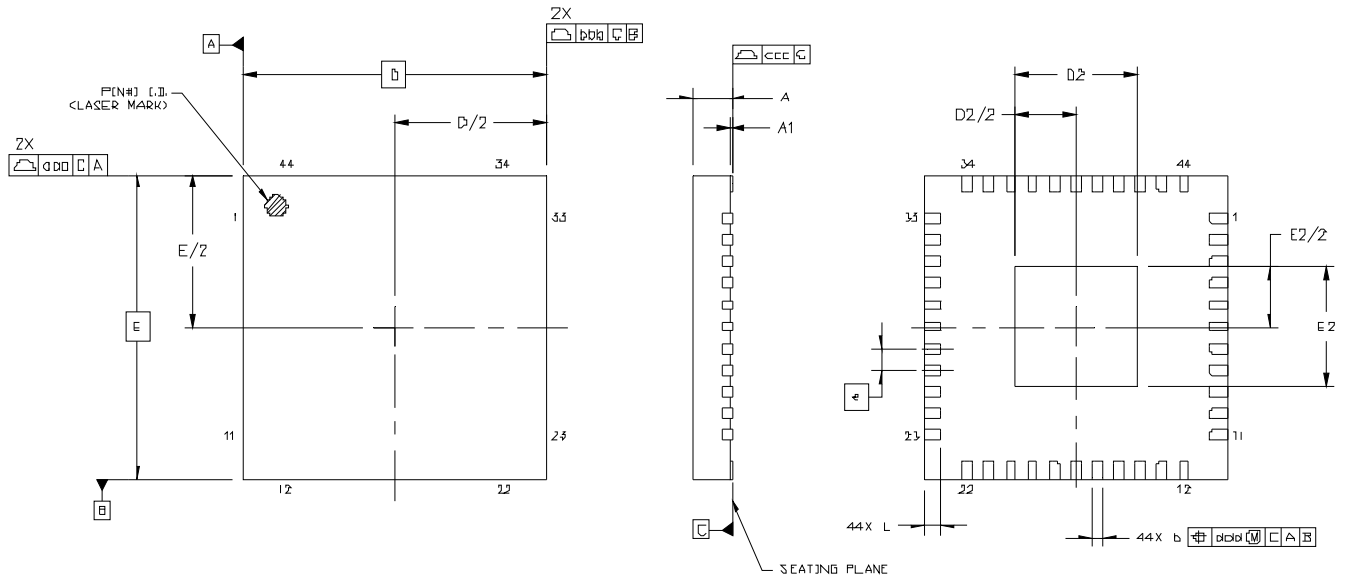

Figure 12. Si53315 7x7 mm 44-QFN Package Diagram

Table 19. Package Diagram Dimensions

Dimension	MIN	NOM	MAX
A	0.80	0.85	0.90
A1	0.00	0.02	0.05
b	0.18	0.25	0.30
D	7.00 BSC		
D2	2.65	2.80	2.95
e	0.50 BSC		
E	7.00 BSC		
E2	2.65	2.80	2.95
L	0.30	0.40	0.50
aaa	—	—	0.10
bbb	—	—	0.10
ccc	—	—	0.08
ddd	—	—	0.10
<b>Notes:</b>			
1. All dimensions shown are in millimeters (mm) unless otherwise noted.			
2. Dimensioning and Tolerancing per ANSI Y14.5M-1994.			
3. This drawing conforms to the JEDEC Solid State Outline MO-220.			
4. Recommended card reflow profile is per the JEDEC/IPC J-STD-020 specification for Small Body Components.			

## 6. PCB Land Pattern

### 6.1. 7x7 mm 44-QFN Package Land Pattern

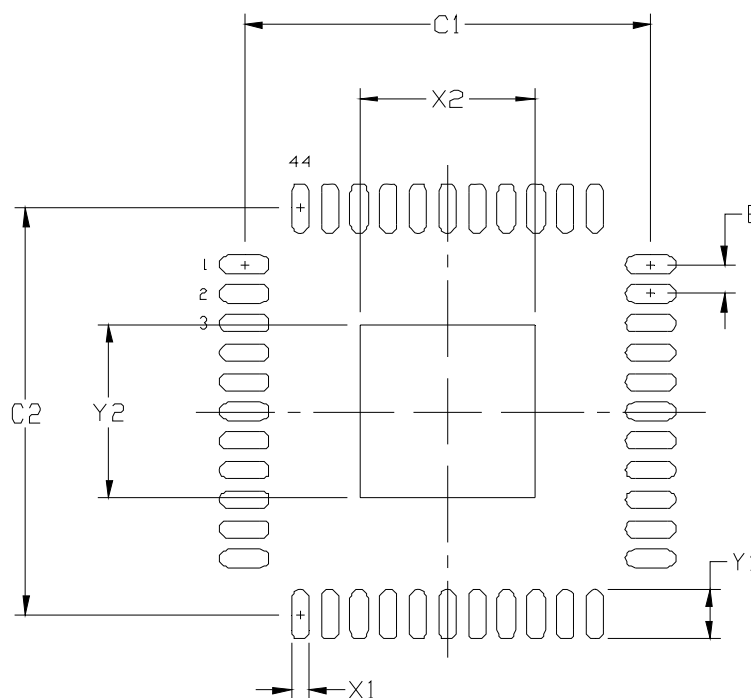

Figure 13. Si53315 7x7 mm 44-QFN Package Land Pattern

Table 20. PCB Land Pattern

Dimension	Min	Max	Dimension	Min	Max
C1	6.80	6.90	X2	2.85	2.95
C2	6.80	6.90	Y1	0.75	0.85
E	0.50 BSC		Y2	2.85	2.95
X1	0.20	0.30			

#### Notes:

##### General

1. All dimensions shown are in millimeters (mm) unless otherwise noted.
2. This Land Pattern Design is based on the IPC-7351 guidelines.

##### Solder Mask Design

1. All metal pads are to be non-solder mask defined (NSMD). Clearance between the solder mask and the metal pad is to be 60  $\mu\text{m}$  minimum, all the way around the pad.

##### Stencil Design

1. A stainless steel, laser-cut and electro-polished stencil with trapezoidal walls should be used to assure good solder paste release.
2. The stencil thickness should be 0.125 mm (5 mils).
3. The ratio of stencil aperture to land pad size should be 1:1 for all perimeter pads.
4. A 2x2 array of 1.0 mm square openings on 1.45 mm pitch should be used for the center ground pad.

##### Card Assembly

1. A No-Clean, Type-3 solder paste is recommended.
2. The recommended card reflow profile is per the JEDEC/IPC J-STD-020 specification for Small Body Components.

# Si53315

## 7. Top Marking

### 7.1. Si53315 Top Marking



### 7.2. Top Marking Explanation

<b>Mark Method:</b>	Laser	
<b>Font Size:</b>	1.9 Point (26 mils) Right-Justified	
<b>Line 1 Marking:</b>	Device Part Number	<b>53315-B-GM</b>
<b>Line 2 Marking:</b>	YY = Year WW = Work Week	Assigned by Assembly Supplier. Corresponds to the year and work week of the mold date.
	TTTTTT = Mfg Code	Manufacturing Code from the Assembly Purchase Order form.
<b>Line 3 Marking:</b>	Circle = 1.3 mm Diameter Center-Justified	"e3" Pb-Free Symbol
	Country of Origin ISO Code Abbreviation	<b>TW</b>
<b>Line 4 Marking</b>	Circle = 0.75 mm Diameter Filled	Pin 1 Identification

**NOTES:**

## CONTACT INFORMATION

### Silicon Laboratories Inc.

400 West Cesar Chavez  
Austin, TX 78701  
Tel: 1+(512) 416-8500  
Fax: 1+(512) 416-9669  
Toll Free: 1+(877) 444-3032

Please visit the Silicon Labs Technical Support web page:  
<https://www.silabs.com/support/pages/contacttechnicalsupport.aspx>  
and register to submit a technical support request.

### Patent Notice

Silicon Labs invests in research and development to help our customers differentiate in the market with innovative low-power, small size, analog-intensive mixed-signal solutions. Silicon Labs' extensive patent portfolio is a testament to our unique approach and world-class engineering team.

The information in this document is believed to be accurate in all respects at the time of publication but is subject to change without notice. Silicon Laboratories assumes no responsibility for errors and omissions, and disclaims responsibility for any consequences resulting from the use of information included herein. Additionally, Silicon Laboratories assumes no responsibility for the functioning of undescribed features or parameters. Silicon Laboratories reserves the right to make changes without further notice. Silicon Laboratories makes no warranty, representation or guarantee regarding the suitability of its products for any particular purpose, nor does Silicon Laboratories assume any liability arising out of the application or use of any product or circuit, and specifically disclaims any and all liability, including without limitation consequential or incidental damages. Silicon Laboratories products are not designed, intended, or authorized for use in applications intended to support or sustain life, or for any other application in which the failure of the Silicon Laboratories product could create a situation where personal injury or death may occur. Should Buyer purchase or use Silicon Laboratories products for any such unintended or unauthorized application, Buyer shall indemnify and hold Silicon Laboratories harmless against all claims and damages.

Silicon Laboratories and Silicon Labs are trademarks of Silicon Laboratories Inc.  
Other products or brandnames mentioned herein are trademarks or registered trademarks of their respective holders.