6 Channel Capacitive Touch Sensor

General Description

The CAP1106, which incorporates RightTouch® technology, is a multiple channel Capacitive Touch sensor. The CAP1106 contains six (6) individual capacitive touch sensor inputs. The device offers programmable sensitivity for use in touch sensor applications. Each sensor input automatically recalibrates to compensate for gradual environmental changes.

The CAP1106 includes Multiple Pattern Touch recognition that allows the user to select a specific set of buttons to be touched simultaneously. If this pattern is detected, then a status bit is set and an interrupt generated.

Additionally, the CAP1106 includes circuitry and support for enhanced sensor proximity detection.

The CAP1106 offers multiple power states operating at low quiescent currents. In the Standby state of operation, one or more capacitive touch sensor inputs are active.

Deep Sleep is the lowest power state available, drawing 5uA (typical) of current. In this state, no sensor inputs are active. Communications will wake the device.

Applications

- Desktop and Notebook PCs
- LCD Monitors
- Consumer Electronics
- Appliances

Features

- Six (6) Capacitive Touch Sensor Inputs - CAP1106
 - Programmable sensitivity
 - Automatic recalibration
 - Individual thresholds for each button
- Proximity Detection
- Multiple Button Pattern Detection
- Calibrates for Parasitic Capacitance
- Analog Filtering for System Noise Sources
- Press and Hold feature for Volume-like Applications
- Multiple Communication Interfaces
 - SMBus / I²C compliant interface
 - BC-Link interface
- Low Power Operation
 - 5uA quiescent current in Deep Sleep
 - 50uA quiescent current in Standby (1 sensor input monitored)
 - Samples one or more channels in Standby
- Available in 10-pin 3mm x 3mm RoHS compliant DFN package

TO OUR VALUED CUSTOMERS

It is our intention to provide our valued customers with the best documentation possible to ensure successful use of your Microchip products. To this end, we will continue to improve our publications to better suit your needs. Our publications will be refined and enhanced as new volumes and updates are introduced.

If you have any questions or comments regarding this publication, please contact the Marketing Communications Department via E-mail at docerrors@microchip.com. We welcome your feedback.

Most Current Data Sheet

To obtain the most up-to-date version of this data sheet, please register at our Worldwide Web site at:

<http://www.microchip.com>

You can determine the version of a data sheet by examining its literature number found on the bottom outside corner of any page. The last character of the literature number is the version number, (e.g., DS30000000A is version A of document DS30000000).

Errata

An errata sheet, describing minor operational differences from the data sheet and recommended workarounds, may exist for current devices. As device/documentation issues become known to us, we will publish an errata sheet. The errata will specify the revision of silicon and revision of document to which it applies.

To determine if an errata sheet exists for a particular device, please check with one of the following:

- Microchip's Worldwide Web site; <http://www.microchip.com>
- Your local Microchip sales office (see last page)

When contacting a sales office, please specify which device, revision of silicon and data sheet (include -literature number) you are using.

Customer Notification System

Register on our web site at www.microchip.com to receive the most current information on all of our products.

Table of Contents

1.0 Block Diagram	4
2.0 Pin Description	5
3.0 Electrical Specifications	7
4.0 Communications	10
5.0 General Description	14
6.0 Register Description	18
7.0 Package Information	39
Appendix A: Device Delta	42
Appendix B: Data Sheet Revision History	43
The Microchip Web Site	46
Customer Change Notification Service	46
Customer Support	46
Product Identification System	47

CAP1106

1.0 BLOCK DIAGRAM

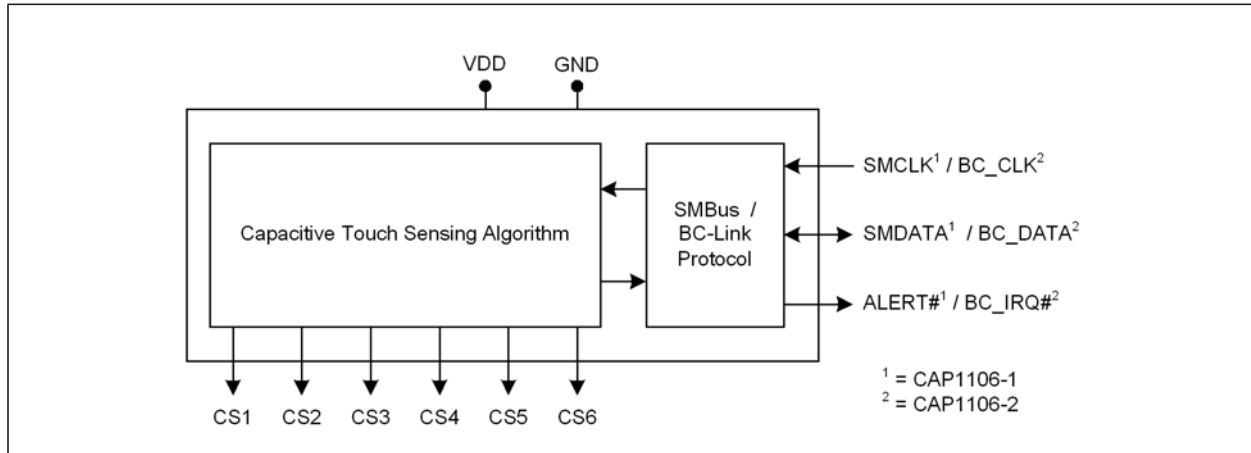

2.0 PIN DESCRIPTION

FIGURE 2-1: CAP1106 Pin Diagram (10-Pin DFN)

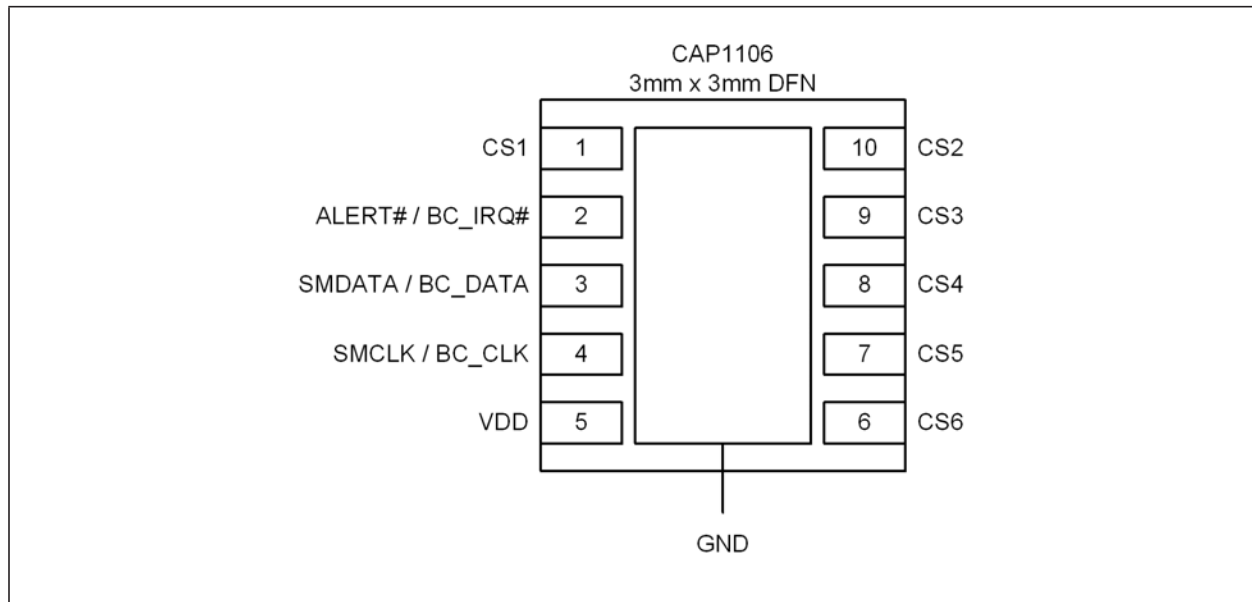

TABLE 2-1: PIN DESCRIPTION FOR CAP1106

Pin Number	Pin Name	Pin Function	Pin Type	Unused Connection
1	CS1	Capacitive Touch Sensor Input 1	AIO	Connect to Ground
2	ALERT# / BC_IRQ#	ALERT# - Active low alert / interrupt output for SMBus alert	OD (5V)	Connect to Ground
		ALERT# - Active high alert / interrupt output for SMBus alert	DO	leave open
		BC_IRQ# - Active low interrupt / optional for BC-Link	OD (5V)	Connect to Ground
		BC_IRQ# - Active high push-pull interrupt / optional for BC-Link	DO	leave open
3	SMDATA / BC_DATA	SMDATA - Bi-directional, open-drain SMBus data - requires pull-up resistor	DIOD (5V)	n/a
		BC_DATA - Bi-directional, open-drain BC-Link data - requires pull-up resistor	DIO	
4	SMCLK / BC_CLK	SMCLK - SMBus clock input - requires pull-up resistor	DI (5V)	n/a
		BC_CLK - BC-Link clock input	DI (5V)	
5	VDD	Positive Power supply	Power	n/a
6	CS6	Capacitive Touch Sensor Input 6	AIO	Connect to Ground

CAP1106

TABLE 2-1: PIN DESCRIPTION FOR CAP1106 (CONTINUED)

Pin Number	Pin Name	Pin Function	Pin Type	Unused Connection
7	CS5	Capacitive Touch Sensor Input 5	AIO	Connect to Ground
8	CS4	Capacitive Touch Sensor Input 4	AIO	Connect to Ground
9	CS3	Capacitive Touch Sensor Input 3	AIO	Connect to Ground
10	CS2	Capacitive Touch Sensor Input 2	AIO	Connect to Ground
Bottom Pad	GND	Ground	Power	n/a

APPLICATION NOTE: When the ALERT# pin is configured as an active low output, it will be open drain. When it is configured as an active high output, it will be push-pull.

APPLICATION NOTE: For the 5V tolerant pins that have a pull-up resistor, the pull-up voltage must not exceed 3.6V when the CAP1106 is unpowered.

The pin types are described in [Table 2-2](#). All pins labeled with (5V) are 5V tolerant.

TABLE 2-2: PIN TYPES

Pin Type	Description
Power	This pin is used to supply power or ground to the device.
DI	Digital Input - This pin is used as a digital input. This pin is 5V tolerant.
AIO	Analog Input / Output -This pin is used as an I/O for analog signals.
DIOD	Digital Input / Open Drain Output - This pin is used as a digital I/O. When it is used as an output, it is open drain and requires a pull-up resistor. This pin is 5V tolerant.
OD	Open Drain Digital Output - This pin is used as a digital output. It is open drain and requires a pull-up resistor. This pin is 5V tolerant.
DO	Push-pull Digital Output - This pin is used as a digital output and can sink and source current.
DIO	Push-pull Digital Input / Output - This pin is used as an I/O for digital signals.

3.0 ELECTRICAL SPECIFICATIONS

TABLE 3-1: ABSOLUTE MAXIMUM RATINGS

Voltage on 5V tolerant pins (V_{5VT_PIN})	-0.3 to 5.5	V
Voltage on 5V tolerant pins ($ V_{5VT_PIN} - V_{DD} $) Note 3-2	0 to 3.6	V
Voltage on VDD pin	-0.3 to 4	V
Voltage on any other pin to GND	-0.3 to $V_{DD} + 0.3$	V
Package Power Dissipation up to $T_A = 85^\circ\text{C}$ for 10 pin DFN (see Note 3-3)	0.7	W
Junction to Ambient (θ_{JA})	77.7	$^\circ\text{C/W}$
Operating Ambient Temperature Range	-40 to 125	$^\circ\text{C}$
Storage Temperature Range	-55 to 150	$^\circ\text{C}$
ESD Rating, All Pins, HBM	8000	V

Note 3-1 Stresses above those listed could cause permanent damage to the device. This is a stress rating only and functional operation of the device at any other condition above those indicated in the operation sections of this specification is not implied.

Note 3-2 For the 5V tolerant pins that have a pull-up resistor, the voltage difference between V_{5VT_PIN} and V_{DD} must never exceed 3.6V.

Note 3-3 The Package Power Dissipation specification assumes a recommended thermal via design consisting of a 2x2 matrix of 0.3mm (12mil) vias at 1.0mm pitch connected to the ground plane with a 1.6 x 2.3mm thermal landing.

CAP1106

TABLE 3-2: ELECTRICAL SPECIFICATIONS

V _{DD} = 3V to 3.6V, T _A = 0°C to 85°C, all typical values at T _A = 27°C unless otherwise noted.						
Characteristic	Symbol	Min	Typ	Max	Unit	Conditions
DC Power						
Supply Voltage	V _{DD}	3.0	3.3	3.6	V	
Supply Current	I _{STBY}		120	170	uA	Standby state active 1 sensor input monitored Default conditions (8 avg, 70ms cycle time)
	I _{STBY}		50		uA	Standby state active 1 sensor input monitored 1 avg, 140ms cycle time,
	I _{DSLEEP}		5	15	uA	Deep Sleep state active No communications T _A < 40°C 3.135 < V _{DD} < 3.465V
	I _{DD}		500	600	uA	Capacitive Sensing Active
Capacitive Touch Sensor Inputs						
Maximum Base Capacitance	C _{BASE}		50		pF	Pad untouched
Minimum Detectable Capacitive Shift	ΔC _{TOUCH}	20			fF	Pad touched - default conditions (1 avg, 35ms cycle time, 1x sensitivity)
Recommended Cap Shift	ΔC _{TOUCH}	0.1		2	pF	Pad touched - Not tested
Power Supply Rejection	PSR		±3	±10	counts / V	Untouched Current Counts Base Capacitance 5pF - 50pF Maximum sensitivity Negative Delta Counts disabled All other parameters default
Timing						
Time to communications ready	t _{COMM_DLY}			15	ms	
Time to first conversion ready	t _{CONV_DLY}		170	200	ms	
I/O Pins						
Output Low Voltage	V _{OL}			0.4	V	I _{SINK_IO} = 8mA
Output High Voltage	V _{OH}	V _{DD} - 0.4			V	I _{SOURCE_IO} = 8mA
Input High Voltage	V _{IH}	2.0			V	
Input Low Voltage	V _{IL}			0.8	V	
Leakage Current	I _{LEAK}			±5	uA	powered or unpowered T _A < 85°C pull-up voltage ≤ 3.6V if unpowered
SMBus Timing						
Input Capacitance	C _{IN}		5		pF	
Clock Frequency	f _{SMB}	10		400	kHz	
Spike Suppression	t _{SP}			50	ns	
Bus Free Time Stop to Start	t _{BUF}	1.3			us	
Start Setup Time	t _{SU:STA}	0.6			us	

TABLE 3-2: ELECTRICAL SPECIFICATIONS (CONTINUED)

V _{DD} = 3V to 3.6V, T _A = 0°C to 85°C, all typical values at T _A = 27°C unless otherwise noted.						
Characteristic	Symbol	Min	Typ	Max	Unit	Conditions
Start Hold Time	t _{HD:STA}	0.6			us	
Stop Setup Time	t _{SU:STO}	0.6			us	
Data Hold Time	t _{HD:DAT}	0			us	When transmitting to the master
Data Hold Time	t _{HD:DAT}	0.3			us	When receiving from the master
Data Setup Time	t _{SU:DAT}	0.6			us	
Clock Low Period	t _{LOW}	1.3			us	
Clock High Period	t _{HIGH}	0.6			us	
Clock / Data Fall Time	t _{FALL}			300	ns	Min = 20+0.1C _{LOAD} ns
Clock / Data Rise Time	t _{RISE}			300	ns	Min = 20+0.1C _{LOAD} ns
Capacitive Load	C _{LOAD}			400	pF	per bus line
BC-Link Timing						
Clock Period	t _{CLK}	250			ns	
Data Hold Time	t _{HD:DAT}	0			ns	
Data Setup Time	t _{SU:DAT}	30			ns	Data must be valid before clock
Clock Duty Cycle	Duty	40	50	60	%	

Note 3-4 The ALERT pin will not glitch high or low at power up if connected to VDD or another voltage.

Note 3-5 The SMCLK and SMDATA pins will not glitch low at power up if connected to VDD or another voltage.

CAP1106

4.0 COMMUNICATIONS

4.1 Communications

The CAP1106 communicates using the SMBus or I²C protocol. If the proprietary BC-Link protocol is required for your application, please contact your Microchip representative for ordering instructions. Regardless of the communications mechanism, the device functionality remains unchanged.

4.1.1 SMBUS (I²C) COMMUNICATIONS

The CAP1106 supports the following protocols: Send Byte, Receive Byte, Read Byte, Write Byte, Read Block, and Write Block. In addition, the device supports I²C formatting for block read and block write protocols.

See [Section 4.2](#) and [Section 4.3](#) for more information on the SMBus bus and protocols respectively.

4.1.2 BC-LINK COMMUNICATIONS

The CAP1106 supports the read byte protocol and the write byte protocol.

See [Section 4.5](#) for more information on the BC-Link Bus and protocols respectively.

APPLICATION NOTE: Upon power up, the CAP1106 will not respond to any communications for up to 15ms. After this time, full functionality is available.

4.2 System Management Bus

The CAP1106 communicates with a host controller, such as an SIO, through the SMBus. The SMBus is a two-wire serial communication protocol between a computer host and its peripheral devices. A detailed timing diagram is shown in [Figure 4-1](#). Stretching of the SMCLK signal is supported; however, the CAP1106 will not stretch the clock signal.

FIGURE 4-1: SMBus Timing Diagram

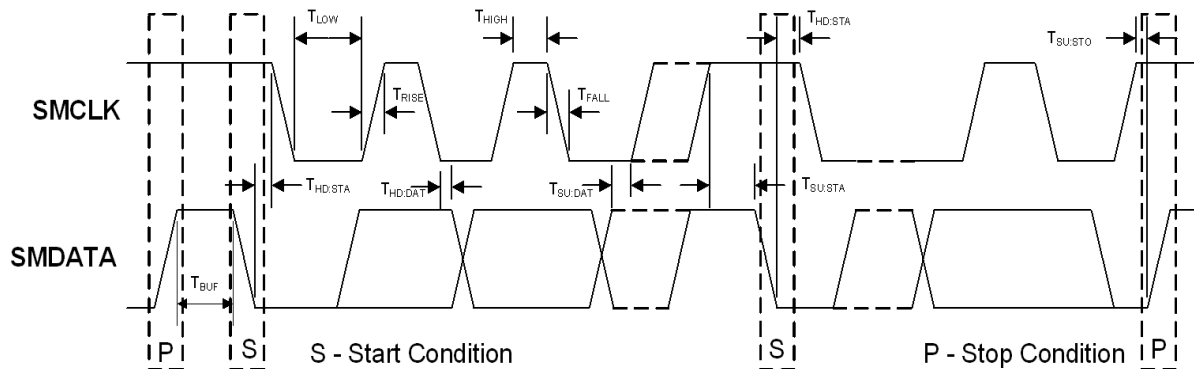

4.2.1 SMBUS START BIT

The SMBus Start bit is defined as a transition of the SMBus Data line from a logic '1' state to a logic '0' state while the SMBus Clock line is in a logic '1' state.

4.2.2 SMBUS ADDRESS AND RD / \overline{WR} BIT

The SMBus Address Byte consists of the 7-bit client address followed by the RD / \overline{WR} indicator bit. If this RD / \overline{WR} bit is a logic '0', then the SMBus Host is writing data to the client device. If this RD / \overline{WR} bit is a logic '1', then the SMBus Host is reading data from the client device.

The CAP1106 responds to SMBus address 0101_000(r/w).

4.2.3 SMBUS DATA BYTES

All SMBus Data bytes are sent most significant bit first and composed of 8-bits of information.

4.2.4 SMBUS ACK AND NACK BITS

The SMBus client will acknowledge all data bytes that it receives. This is done by the client device pulling the SMBus Data line low after the 8th bit of each byte that is transmitted. This applies to both the Write Byte and Block Write protocols.

The Host will NACK (not acknowledge) the last data byte to be received from the client by holding the SMBus data line high after the 8th data bit has been sent. For the Block Read protocol, the Host will ACK each data byte that it receives except the last data byte.

4.2.5 SMBUS STOP BIT

The SMBus Stop bit is defined as a transition of the SMBus Data line from a logic '0' state to a logic '1' state while the SMBus clock line is in a logic '1' state. When the CAP1106 detects an SMBus Stop bit and it has been communicating with the SMBus protocol, it will reset its client interface and prepare to receive further communications.

4.2.6 SMBUS TIMEOUT

The CAP1106 includes an SMBus timeout feature. Following a 30ms period of inactivity on the SMBus where the SMCLK pin is held low, the device will timeout and reset the SMBus interface.

The timeout function defaults to disabled. It can be enabled by setting the TIMEOUT bit in the Configuration register (see [Section 6.6, "Configuration Registers"](#)).

4.2.7 SMBUS AND I²C COMPATIBILITY

The major differences between SMBus and I²C devices are highlighted here. For more information, refer to the SMBus 2.0 and I²C specifications. For information on using the CAP1106 in an I²C system, refer to SMSC AN 14.0 SMSC Dedicated Slave Devices in I²C Systems.

1. CAP1106 supports I²C fast mode at 400kHz. This covers the SMBus max time of 100kHz.
2. Minimum frequency for SMBus communications is 10kHz.
3. The SMBus client protocol will reset if the clock is held at a logic '0' for longer than 30ms. This timeout functionality is disabled by default in the CAP1106 and can be enabled by writing to the TIMEOUT bit. I²C does not have a timeout.
4. The SMBus client protocol will reset if both the clock and data lines are held at a logic '1' for longer than 200μs (idle condition). This function is disabled by default in the CAP1106 and can be enabled by writing to the TIMEOUT bit. I²C does not have an idle condition.
5. I²C devices do not support the Alert Response Address functionality (which is optional for SMBus).
6. I²C devices support block read and write differently. I²C protocol allows for unlimited number of bytes to be sent in either direction. The SMBus protocol requires that an additional data byte indicating number of bytes to read / write is transmitted. The CAP1106 supports I²C formatting only.

4.3 SMBus Protocols

The CAP1106 is SMBus 2.0 compatible and supports Write Byte, Read Byte, Send Byte, and Receive Byte as valid protocols as shown below.

All of the below protocols use the convention in [Table 4-1](#).

TABLE 4-1: PROTOCOL FORMAT

Data Sent to Device	Data Sent to the Host
Data sent	Data sent

CAP1106

4.3.1 SMBUS WRITE BYTE

The Write Byte is used to write one byte of data to a specific register as shown in [Table 4-2](#).

TABLE 4-2: WRITE BYTE PROTOCOL

Start	Slave Address	WR	ACK	Register Address	ACK	Register Data	ACK	Stop
1 -> 0	0101_000	0	0	XXh	0	XXh	0	0 -> 1

4.3.2 SMBUS READ BYTE

The Read Byte protocol is used to read one byte of data from the registers as shown in [Table 4-3](#).

TABLE 4-3: READ BYTE PROTOCOL

Start	Slave Address	WR	ACK	Register Address	ACK	Start	Client Address	RD	ACK	Register Data	NACK	Stop
1->0	0101_000	0	0	XXh	0	1->0	0101_000	1	0	XXh	1	0->1

4.3.3 SMBUS SEND BYTE

The Send Byte protocol is used to set the internal address register pointer to the correct address location. No data is transferred during the Send Byte protocol as shown in [Table 4-4](#).

APPLICATION NOTE: The Send Byte protocol is not functional in Deep Sleep (i.e., DSLEEP bit is set).

TABLE 4-4: SEND BYTE PROTOCOL

Start	Slave Address	WR	ACK	Register Address	ACK	Stop
1 -> 0	0101_000	0	0	XXh	0	0 -> 1

4.3.4 SMBUS RECEIVE BYTE

The Receive Byte protocol is used to read data from a register when the internal register address pointer is known to be at the right location (e.g., set via Send Byte). This is used for consecutive reads of the same register as shown in [Table 4-5](#).

APPLICATION NOTE: The Receive Byte protocol is not functional in Deep Sleep (i.e., DSLEEP bit is set).

TABLE 4-5: RECEIVE BYTE PROTOCOL

Start	Slave Address	RD	ACK	Register Data	NACK	Stop
1 -> 0	0101_000	1	0	XXh	1	0 -> 1

4.4 I²C Protocols

The CAP1106 supports I²C Block Write and Block Read.

The protocols listed below use the convention in [Table 4-1](#).

4.4.1 BLOCK WRITE

The Block Write is used to write multiple data bytes to a group of contiguous registers as shown in [Table 4-6](#).

APPLICATION NOTE: When using the Block Write protocol, the internal address pointer will be automatically incremented after every data byte is received. It will wrap from FFh to 00h.

TABLE 4-6: BLOCK WRITE PROTOCOL

Start	Slave Address	WR	ACK	Register Address	ACK	Register Data	ACK
1 -> 0	0101_000	0	0	XXh	0	XXh	0
Register Data	ACK	Register Data	ACK	...	Register Data	ACK	Stop
XXh	0	XXh	0	...	XXh	0	0 -> 1

4.4.2 BLOCK READ

The Block Read is used to read multiple data bytes from a group of contiguous registers as shown in [Table 4-7](#).

APPLICATION NOTE: When using the Block Read protocol, the internal address pointer will be automatically incremented after every data byte is received. It will wrap from FFh to 00h.

TABLE 4-7: BLOCK READ PROTOCOL

Start	Slave Address	WR	ACK	Register Address	ACK	Start	Slave Address	RD	ACK	Register Data
1->0	0101_000	0	0	XXh	0	1 -> 0	0101_000	1	0	XXh
ACK	Register Data	ACK	Register Data	ACK	Register Data	ACK	...	Register Data	NACK	Stop
0	XXh	0	XXh	0	XXh	0	...	XXh	1	0 -> 1

4.5 BC-Link Interface

The BC-Link is a proprietary bus developed to allow communication between a host controller device to a companion device. This device uses this serial bus to read and write registers and for interrupt processing. The interface uses a data port concept, where the base interface has an address register, data register and a control register, defined in the 8051's SFR space.

Refer to documentation for the BC-Link compatible host controller for details on how to access the CAP1106-2 via the BC-Link Interface.

CAP1106

5.0 GENERAL DESCRIPTION

The CAP1106 is a multiple channel Capacitive Touch sensor. The CAP1106 contains six (6) individual capacitive touch sensor inputs. The device offers programmable sensitivity for use in touch sensor applications. Each sensor input automatically recalibrates to compensate for gradual environmental changes.

The CAP1106 offers multiple power states. It operates at the lowest quiescent current during its Deep Sleep state. In the low power Standby state, it can monitor one or more channels and respond to communications normally.

The device communicates with a host controller using BC-Link bus, or via SMBus / I²C. The host controller may poll the device for updated information at any time or it may configure the device to flag an interrupt whenever a touch is detected on any sensor pad.

A typical system diagram for the CAP1106 is shown in [Figure 5-1](#).

FIGURE 5-1: System Diagram for CAP1106

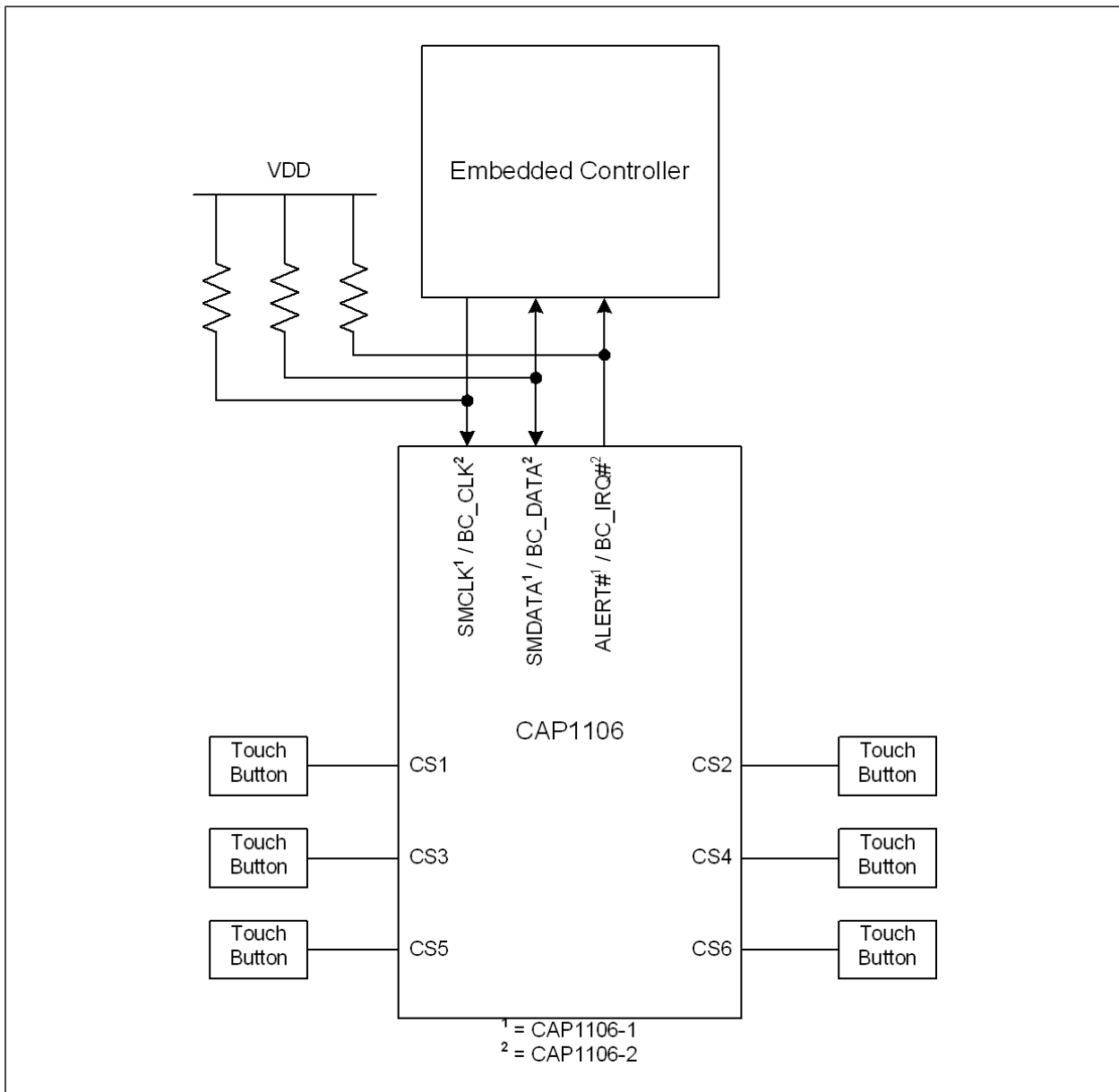

5.1 Power States

The CAP1106 has three operating states depending on the status of the STBY and DSLEEP bits. When the device transitions between power states, previously detected touches (for inactive channels) are cleared and the status bits reset.

1. Fully Active - The device is fully active. It is monitoring all active capacitive sensor inputs.
2. Standby - The device is in a lower power state. It will measure a programmable number of channels using the Standby Configuration controls (see [Section 6.20](#) through [Section 6.22](#)). Interrupts will still be generated based on the active channels. The device will still respond to communications normally and can be returned to the Fully Active state of operation by clearing the STBY bit.
3. Deep Sleep - The device is in its lowest power state. It is not monitoring any capacitive sensor inputs. While in Deep Sleep, the device can be awakened by SMBus or SPI communications targeting the device. This will not cause the DSLEEP to be cleared so the device will return to Deep Sleep once all communications have stopped.

APPLICATION NOTE: The version of the CAP1106, which communicates using the BC-Link protocol, does not support Deep Sleep.

5.2 Capacitive Touch Sensing

The CAP1106 contains six (6) independent capacitive touch sensor inputs. Each sensor input has dynamic range to detect a change of capacitance due to a touch. Additionally, each sensor input can be configured to be automatically and routinely re-calibrated.

5.2.1 SENSING CYCLE

Each capacitive touch sensor input has controls to be activated and included in the sensing cycle. When the device is active, it automatically initiates a sensing cycle and repeats the cycle every time it finishes. The cycle polls through each active sensor input starting with CS1 and extending through CS6. As each capacitive touch sensor input is polled, its measurement is compared against a baseline “Not Touched” measurement. If the delta measurement is large enough, a touch is detected and an interrupt is generated.

The sensing cycle time is programmable (see [Section 6.10](#), “[Averaging and Sampling Configuration Register](#)”).

5.2.2 RECALIBRATING SENSOR INPUTS

There are various options for recalibrating the capacitive touch sensor inputs. Recalibration re-sets the Base Count Registers ([Section 6.24](#), “[Sensor Input Base Count Registers](#)”) which contain the “not touched” values used for touch detection comparisons.

APPLICATION NOTE: The device will recalibrate all sensor inputs that were disabled when it transitions from Standby. Likewise, the device will recalibrate all sensor inputs when waking out of Deep Sleep.

5.2.2.1 Manual Recalibration

The Calibration Activate Registers ([Section 6.11](#), “[Calibration Activate Register](#)”) force recalibration of selected sensor inputs. When a bit is set, the corresponding capacitive touch sensor input will be recalibrated (both analog and digital). The bit is automatically cleared once the recalibration routine has finished.

Note: During this recalibration routine, the sensor inputs will not detect a press for up to 200ms and the Sensor Base Count Register values will be invalid. In addition, any press on the corresponding sensor pads will invalidate the recalibration.

5.2.2.2 Automatic Recalibration

Each sensor input is regularly recalibrated at a programmable rate (see [Section 6.17](#), “[Recalibration Configuration Register](#)”). By default, the recalibration routine stores the average 64 previous measurements and periodically updates the base “not touched” setting for the capacitive touch sensor input.

Note: Automatic recalibration only works when the delta count is below the active sensor input threshold. It is disabled when a touch is detected.

5.2.2.3 Negative Delta Count Recalibration

It is possible that the device loses sensitivity to a touch. This may happen as a result of a noisy environment, an accidental recalibration during a touch, or other environmental changes. When this occurs, the base untouched sensor input may generate negative delta count values. The NEG_DELTA_CNT bits (see [Section 6.17, "Recalibration Configuration Register"](#)) can be set to force a recalibration after a specified number of consecutive negative delta readings.

Note: During this recalibration, the device will not respond to touches.

5.2.2.4 Delayed Recalibration

It is possible that a “stuck button” occurs when something is placed on a button which causes a touch to be detected for a long period. By setting the MAX_DUR_EN bit (see [Section 6.6, "Configuration Registers"](#)), a recalibration can be forced when a touch is held on a button for longer than the duration specified in the MAX_DUR bits (see [Section 6.8, "Sensor Input Configuration Register"](#)).

Note: Delayed recalibration only works when the delta count is above the active sensor input threshold. If enabled, it is invoked when a sensor pad touch is held longer than the MAX_DUR bit setting.

5.2.3 PROXIMITY DETECTION

Each sensor input can be configured to detect changes in capacitance due to proximity of a touch. This circuitry detects the change of capacitance that is generated as an object approaches, but does not physically touch, the enabled sensor pad(s). When a sensor input is selected to perform proximity detection, it will be sampled from 1x to 128x per sampling cycle. The larger the number of samples that are taken, the greater the range of proximity detection is available at the cost of an increased overall sampling time.

5.2.4 MULTIPLE TOUCH PATTERN DETECTION

The multiple touch pattern (MTP) detection circuitry can be used to detect lid closure or other similar events. An event can be flagged based on either a minimum number of sensor inputs or on specific sensor inputs simultaneously exceeding an MTP threshold or having their Noise Flag Status Register bits set. An interrupt can also be generated. During an MTP event, all touches are blocked (see [Section 6.15, "Multiple Touch Pattern Configuration Register"](#)).

5.2.5 LOW FREQUENCY NOISE DETECTION

Each sensor input has an EMI noise detector that will sense if low frequency noise is injected onto the input with sufficient power to corrupt the readings. If this occurs, the device will reject the corrupted sample and set the corresponding bit in the Noise Status register to a logic '1'.

5.2.6 RF NOISE DETECTION

Each sensor input contains an integrated RF noise detector. This block will detect injected RF noise on the CS pin. The detector threshold is dependent upon the noise frequency. If RF noise is detected on a CS line, that sample is removed and not compared against the threshold.

5.3 ALERT# Pin

The ALERT# pin is an active low (or active high when configured) output that is driven when an interrupt event is detected.

Whenever an interrupt is generated, the INT bit (see [Section 6.1, "Main Control Register"](#)) is set. The ALERT# pin is cleared when the INT bit is cleared by the user. Additionally, when the INT bit is cleared by the user, status bits are only cleared if no touch is detected.

5.3.1 SENSOR INTERRUPT BEHAVIOR

The sensor interrupts are generated in one of two ways:

1. An interrupt is generated when a touch is detected and, as a user selectable option, when a release is detected (by default - see [Section 6.6](#)). See [Figure 5-3](#).

- If the repeat rate is enabled then, so long as the touch is held, another interrupt will be generated based on the programmed repeat rate (see Figure 5-2).

When the repeat rate is enabled, the device uses an additional control called MPRESS that determines whether a touch is flagged as a simple “touch” or a “press and hold”. The MPRESS[3:0] bits set a minimum press timer. When the button is touched, the timer begins. If the sensor pad is released before the minimum press timer expires, it is flagged as a touch and an interrupt is generated upon release. If the sensor input detects a touch for longer than this timer value, it is flagged as a “press and hold” event. So long as the touch is held, interrupts will be generated at the programmed repeat rate and upon release (if enabled).

APPLICATION NOTE: Figure 5-2 and Figure 5-3 show default operation which is to generate an interrupt upon sensor pad release and an active-low ALERT# pin.

APPLICATION NOTE: The host may need to poll the device twice to determine that a release has been detected.

FIGURE 5-2: Sensor Interrupt Behavior - Repeat Rate Enabled

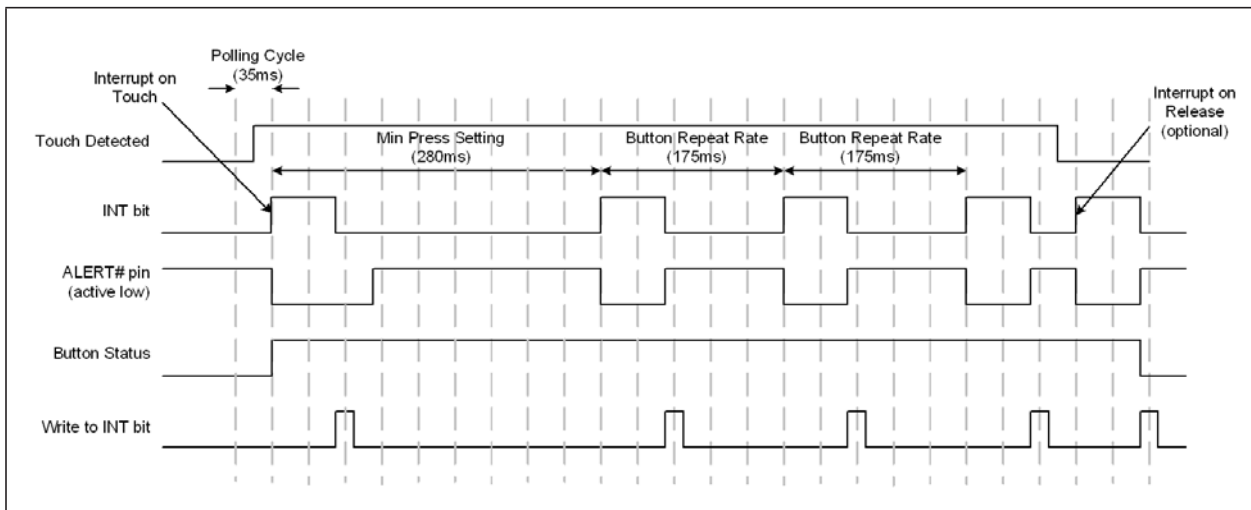
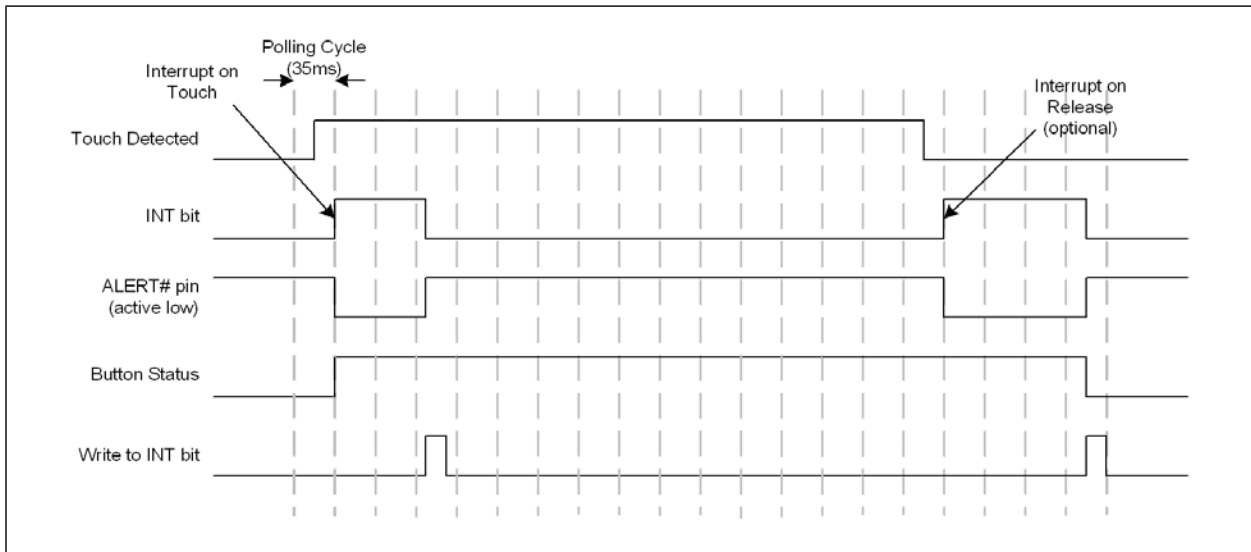

FIGURE 5-3: Sensor Interrupt Behavior - No Repeat Rate Enabled



CAP1106

6.0 REGISTER DESCRIPTION

The registers shown in [Table 6-1](#) are accessible through the communications protocol. An entry of '-' indicates that the bit is not used and will always read '0'.

TABLE 6-1: REGISTER SET IN HEXADECIMAL ORDER

Register Address	R/W	Register Name	Function	Default Value	Page
00h	R/W	Main Control	Controls general power states and power dissipation	00h	Page 20
02h	R	General Status	Stores general status bits	00h	Page 21
03h	R	Sensor Input Status	Returns the state of the sampled capacitive touch sensor inputs	00h	Page 21
0Ah	R	Noise Flag Status	Stores the noise flags for sensor inputs	00h	Page 22
10h	R	Sensor Input 1 Delta Count	Stores the delta count for CS1	00h	Page 22
11h	R	Sensor Input 2 Delta Count	Stores the delta count for CS2	00h	Page 22
12h	R	Sensor Input 3 Delta Count	Stores the delta count for CS3	00h	Page 22
13h	R	Sensor Input 4 Delta Count	Stores the delta count for CS4	00h	Page 22
14h	R	Sensor Input 5 Delta Count	Stores the delta count for CS5	00h	Page 22
15h	R	Sensor Input 6 Delta Count	Stores the delta count for CS6	00h	Page 22
1Fh	R/W	Sensitivity Control	Controls the sensitivity of the threshold and delta counts and data scaling of the base counts	2Fh	Page 22
20h	R/W	Configuration	Controls general functionality	20h	Page 24
21h	R/W	Sensor Input Enable	Controls whether the capacitive touch sensor inputs are sampled	3Fh	Page 25
22h	R/W	Sensor Input Configuration	Controls max duration and auto-repeat delay for sensor inputs operating in the full power state	A4h	Page 25
23h	R/W	Sensor Input Configuration 2	Controls the MPRESS controls for all sensor inputs	07h	Page 26
24h	R/W	Averaging and Sampling Config	Controls averaging and sampling window	39h	Page 27
26h	R/W	Calibration Activate	Forces re-calibration for capacitive touch sensor inputs	00h	Page 28
27h	R/W	Interrupt Enable	Enables Interrupts associated with capacitive touch sensor inputs	3Fh	Page 29
28h	R/W	Repeat Rate Enable	Enables repeat rate for all sensor inputs	3Fh	Page 29
2Ah	R/W	Multiple Touch Configuration	Determines the number of simultaneous touches to flag a multiple touch condition	80h	Page 30
2Bh	R/W	Multiple Touch Pattern Configuration	Determines the multiple touch pattern (MTP) configuration	00h	Page 30
2Dh	R/W	Multiple Touch Pattern	Determines the pattern or number of sensor inputs used by the MTP circuitry	3Fh	Page 31

TABLE 6-1: REGISTER SET IN HEXADECIMAL ORDER (CONTINUED)

Register Address	R/W	Register Name	Function	Default Value	Page
2Fh	R/W	Recalibration Configuration	Determines re-calibration timing and sampling window	8Ah	Page 32
30h	R/W	Sensor Input 1 Threshold	Stores the delta count threshold to determine a touch for Capacitive Touch Sensor Input 1	40h	Page 33
31h	R/W	Sensor Input 2 Threshold	Stores the delta count threshold to determine a touch for Capacitive Touch Sensor Input 2	40h	Page 33
32h	R/W	Sensor Input 3 Threshold	Stores the delta count threshold to determine a touch for Capacitive Touch Sensor Input 3	40h	Page 33
33h	R/W	Sensor Input 4 Threshold	Stores the delta count threshold to determine a touch for Capacitive Touch Sensor Input 4	40h	Page 33
34h	R/W	Sensor Input 5 Threshold	Stores the delta count threshold to determine a touch for Capacitive Touch Sensor Input 5	40h	Page 33
35h	R/W	Sensor Input 6 Threshold	Stores the delta count threshold to determine a touch for Capacitive Touch Sensor Input 6	40h	Page 33
38h	R/W	Sensor Input Noise Threshold	Stores controls for selecting the noise threshold for all sensor inputs	01h	Page 33
Standby Configuration Registers					
40h	R/W	Standby Channel	Controls which sensor inputs are enabled while in standby	00h	Page 34
41h	R/W	Standby Configuration	Controls averaging and cycle time while in standby	39h	Page 34
42h	R/W	Standby Sensitivity	Controls sensitivity settings used while in standby	02h	Page 35
43h	R/W	Standby Threshold	Stores the touch detection threshold for active sensor inputs in standby	40h	Page 36
44h	R/W	Configuration 2	Stores additional configuration controls for the device	40h	Page 24
Base Count Registers					
50h	R	Sensor Input 1 Base Count	Stores the reference count value for sensor input 1	C8h	Page 36
51h	R	Sensor Input 2 Base Count	Stores the reference count value for sensor input 2	C8h	Page 36
52h	R	Sensor Input 3 Base Count	Stores the reference count value for sensor input 3	C8h	Page 36
53h	R	Sensor Input 4 Base Count	Stores the reference count value for sensor input 4	C8h	Page 36
54h	R	Sensor Input 5 Base Count	Stores the reference count value for sensor input 5	C8h	Page 36
55h	R	Sensor Input 6 Base Count	Stores the reference count value for sensor input 6	C8h	Page 36
B1h	R	Sensor Input 1 Calibration	Stores the upper 8-bit calibration value for sensor input 1	00h	Page 37

CAP1106

TABLE 6-1: REGISTER SET IN HEXADECIMAL ORDER (CONTINUED)

Register Address	R/W	Register Name	Function	Default Value	Page
B2h	R	Sensor Input 2 Calibration	Stores the upper 8-bit calibration value for sensor input 2	00h	Page 37
B3h	R	Sensor Input 3 Calibration	Stores the upper 8-bit calibration value for sensor input 3	00h	Page 37
B4h	R	Sensor Input 4 Calibration	Stores the upper 8-bit calibration value for sensor input 4	00h	Page 37
B5h	R	Sensor Input 5 Calibration	Stores the upper 8-bit calibration value for sensor input 5	00h	Page 37
B6h	R	Sensor Input 6 Calibration	Stores the upper 8-bit calibration value for sensor input 6	00h	Page 37
B9h	R	Sensor Input Calibration LSB 1	Stores the 2 LSBs of the calibration value for sensor inputs 1 - 4	00h	Page 37
BAh	R	Sensor Input Calibration LSB 2	Stores the 2 LSBs of the calibration value for sensor inputs 5- 6	00h	Page 37
FDh	R	Product ID CAP1106	Stores a fixed value that identifies each product	55h	Page 37
FEh	R	Manufacturer ID	Stores a fixed value that identifies Microchip	5Dh	Page 38
FFh	R	Revision	Stores a fixed value that represents the revision number	83h	Page 38

During Power-On-Reset (POR), the default values are stored in the registers. A POR is initiated when power is first applied to the part and the voltage on the VDD supply surpasses the POR level as specified in the electrical characteristics. Any reads to undefined registers will return 00h. Writes to undefined registers will not have an effect.

When a bit is “set”, this means that the user writes a logic ‘1’ to it. When a bit is “cleared”, this means that the user writes a logic ‘0’ to it.

6.1 Main Control Register

TABLE 6-2: MAIN CONTROL REGISTER

ADDR	R/W	Register	B7	B6	B5	B4	B3	B2	B1	B0	Default
00h	R/W	Main Control	GAIN[1:0]		STBY	DSLEEP	-	-	-	INT	00h

The Main Control register controls the primary power state of the device.

Bits 7 - 6 - GAIN[1:0] - Controls the gain used by the capacitive touch sensing circuitry. As the gain is increased, the effective sensitivity is likewise increased as a smaller delta capacitance is required to generate the same delta count values. The sensitivity settings may need to be adjusted along with the gain settings such that data overflow does not occur.

APPLICATION NOTE: The gain settings apply to both Standby and Active states.

TABLE 6-3: GAIN BIT DECODE

GAIN[1:0]		Capacitive Touch Sensor Gain
1	0	
0	0	1
0	1	2
1	0	4
1	1	8

Bit 5 - STBY - Enables Standby.

- '0' (default) - Sensor input scanning is active.
- '1' - Capacitive touch sensor input scanning is limited to the sensor inputs set in the Standby Channel register (see [Section 6.20](#)). The status registers will not be cleared until read. Sensor inputs that are no longer sampled will flag a release and then remain in a non-touched state.

Bit 4 - DSLEEP - Enables Deep Sleep by deactivating all functions. For the version of the CAP1106, which uses the BC-Link protocol, this bit is ignored.

- '0' (default) - Sensor input scanning is active.
- '1' - All sensor input scanning is disabled.. The status registers are automatically cleared and the INT bit is cleared.

Bit 0 - INT - Indicates that there is an interrupt. When this bit is set, it asserts the ALERT# pin. If a channel detects a touch and its associated interrupt enable bit is not set to a logic '1', no action is taken.

This bit is cleared by writing a logic '0' to it. When this bit is cleared, the ALERT# pin will be deasserted and all status registers will be cleared if the condition has been removed.

- '0' - No interrupt pending.
- '1' - A touch has been detected on one or more channels and the interrupt has been asserted.

6.2 Status Registers

TABLE 6-4: STATUS REGISTERS

ADDR	R/W	Register	B7	B6	B5	B4	B3	B2	B1	B0	Default
02h	R	General Status	-	-	-	-	-	MULT	MTP	TOUCH	00h
03h	R	Sensor Input Status	-	-	CS6	CS5	CS4	CS3	CS2	CS1	00h

All status bits are cleared when the device enters the Deep Sleep (DSLEEP = '1' - see [Section 6.1](#)).

6.2.1 GENERAL STATUS - 02H

Bit 2 - MULT - Indicates that the device is blocking detected touches due to the Multiple Touch detection circuitry (see [Section 6.14](#)). This bit will not cause the INT bit to be set and hence will not cause an interrupt.

Bit 1 - MTP - Indicates that the device has detected a number of sensor inputs that exceed the MTP threshold either via the pattern recognition or via the number of sensor inputs (see [Section 6.15](#)). This bit will cause the INT bit to be set if the MTP_ALERT bit is also set. This bit will not be cleared until the condition that caused it to be set has been removed.

Bit 0 - TOUCH - Indicates that a touch was detected. This bit is set if any bit in the Sensor Input Status register is set.

6.2.2 SENSOR INPUT STATUS - 03H

The Sensor Input Status Register stores status bits that indicate a touch has been detected. A value of '0' in any bit indicates that no touch has been detected. A value of '1' in any bit indicates that a touch has been detected.

All bits are cleared when the INT bit is cleared and if a touch on the respective capacitive touch sensor input is no longer present. If a touch is still detected, the bits will not be cleared (but this will not cause the interrupt to be asserted - see [Section 6.6](#)).

Bit 5 - CS6 - Indicates that a touch was detected on Sensor Input 6.

Bit 4 - CS5 - Indicates that a touch was detected on Sensor Input 5.

Bit 3 - CS4 - Indicates that a touch was detected on Sensor Input 4.

Bit 2 - CS3 - Indicates that a touch was detected on Sensor Input 3.

Bit 1 - CS2 - Indicates that a touch was detected on Sensor Input 2.

Bit 0 - CS1 - Indicates that a touch was detected on Sensor Input 1.

CAP1106

6.3 Noise Flag Status Registers

TABLE 6-5: NOISE FLAG STATUS REGISTERS

ADDR	R/W	Register	B7	B6	B5	B4	B3	B2	B1	B0	Default
0Ah	R	Noise Flag Status	-	-	CS6_ NOISE	CS5_ NOISE	CS4_ NOISE	CS3_ NOISE	CS2_ NOISE	CS1_ NOISE	00h

The Noise Flag Status registers store status bits that are generated from the analog block if the detected noise is above the operating region of the analog detector or the RF noise detector. These bits indicate that the most recently received data from the sensor input is invalid and should not be used for touch detection. So long as the bit is set for a particular channel, the delta count value is reset to 00h and thus no touch is detected.

These bits are not sticky and will be cleared automatically if the analog block does not report a noise error.

APPLICATION NOTE: If the MTP detection circuitry is enabled, these bits count as sensor inputs above the MTP threshold (see [Section 5.2.4, "Multiple Touch Pattern Detection"](#)) even if the corresponding delta count is not. If the corresponding delta count also exceeds the MTP threshold, it is not counted twice.

APPLICATION NOTE: Regardless of the state of the Noise Status bits, if low frequency noise is detected on a sensor input, that sample will be discarded unless the DIS_ANA_NOISE bit is set. As well, if RF noise is detected on a sensor input, that sample will be discarded unless the DIS_RF_NOISE bit is set.

6.4 Sensor Input Delta Count Registers

TABLE 6-6: SENSOR INPUT DELTA COUNT REGISTERS

ADDR	R/W	Register	B7	B6	B5	B4	B3	B2	B1	B0	Default
10h	R	Sensor Input 1 Delta Count	Sign	64	32	16	8	4	2	1	00h
11h	R	Sensor Input 2 Delta Count	Sign	64	32	16	8	4	2	1	00h
12h	R	Sensor Input 3 Delta Count	Sign	64	32	16	8	4	2	1	00h
13h	R	Sensor Input 4 Delta Count	Sign	64	32	16	8	4	2	1	00h
14h	R	Sensor Input 5 Delta Count	Sign	64	32	16	8	4	2	1	00h
15h	R	Sensor Input 6 Delta Count	Sign	64	32	16	8	4	2	1	00h

The Sensor Input Delta Count registers store the delta count that is compared against the threshold used to determine if a touch has been detected. The count value represents a change in input due to the capacitance associated with a touch on one of the sensor inputs and is referenced to a calibrated base "Not Touched" count value. The delta is an instantaneous change and is updated once per sensor input per sensing cycle (see [Section 5.2.1, "Sensing Cycle"](#)).

The value presented is a standard 2's complement number. In addition, the value is capped at a value of 7Fh. A reading of 7Fh indicates that the sensitivity settings are too high and should be adjusted accordingly (see [Section 6.5](#)).

The value is also capped at a negative value of 80h for negative delta counts which may result upon a release.

6.5 Sensitivity Control Register

TABLE 6-7: SENSITIVITY CONTROL REGISTER

ADDR	R/W	Register	B7	B6	B5	B4	B3	B2	B1	B0	Default
1Fh	R/W	Sensitivity Control	-	DELTA_SENSE[2:0]			BASE_SHIFT[3:0]			2Fh	

The Sensitivity Control register controls the sensitivity of a touch detection.

Bits 6-4 DELTA_SENSE[2:0] - Controls the sensitivity of a touch detection. The sensitivity settings act to scale the relative delta count value higher or lower based on the system parameters. A setting of 000b is the most sensitive while a setting of 111b is the least sensitive. At the more sensitive settings, touches are detected for a smaller delta capacitance corresponding to a “lighter” touch. These settings are more sensitive to noise, however, and a noisy environment may flag more false touches with higher sensitivity levels.

APPLICATION NOTE: A value of 128x is the most sensitive setting available. At the most sensitivity settings, the MSB of the Delta Count register represents 64 out of ~25,000 which corresponds to a touch of approximately 0.25% of the base capacitance (or a ΔC of 25fF from a 10pF base capacitance). Conversely, a value of 1x is the least sensitive setting available. At these settings, the MSB of the Delta Count register corresponds to a delta count of 8192 counts out of ~25,000 which corresponds to a touch of approximately 33% of the base capacitance (or a ΔC of 3.33pF from a 10pF base capacitance).

TABLE 6-8: DELTA_SENSE BIT DECODE

DELTA_SENSE[2:0]			Sensitivity Multiplier
2	1	0	
0	0	0	128x (most sensitive)
0	0	1	64x
0	1	0	32x (default)
0	1	1	16x
1	0	0	8x
1	0	1	4x
1	1	0	2x
1	1	1	1x - (least sensitive)

Bits 3 - 0 - BASE_SHIFT[3:0] - Controls the scaling and data presentation of the Base Count registers. The higher the value of these bits, the larger the range and the lower the resolution of the data presented. The scale factor represents the multiplier to the bit-weighting presented in these register descriptions.

APPLICATION NOTE: The BASE_SHIFT[3:0] bits normally do not need to be updated. These settings will not affect touch detection or sensitivity. These bits are sometimes helpful in analyzing the Cap Sensing board performance and stability.

TABLE 6-9: BASE_SHIFT BIT DECODE

BASE_SHIFT[3:0]				Data Scaling Factor
3	2	1	0	
0	0	0	0	1x
0	0	0	1	2x
0	0	1	0	4x
0	0	1	1	8x
0	1	0	0	16x
0	1	0	1	32x
0	1	1	0	64x
0	1	1	1	128x
1	0	0	0	256x
All others				256x (default = 1111b)

6.6 Configuration Registers

TABLE 6-10: CONFIGURATION REGISTERS

ADDR	R/W	Register	B7	B6	B5	B4	B3	B2	B1	B0	Default
20h	R/W	Configuration	TIMEOUT	-	DIS_DIG_NOISE	DIS_ANA_NOISE	MAX_DUR_EN	-	-	-	A0h (Rev B) 20h (rev C)
44h	R/W	Configuration 2	-	ALT_POL	BLK_PWR_CTRL	-	SHOW_RF_NOISE	DIS_RF_NOISE	-	INT_REL_n	40h

The Configuration registers control general global functionality that affects the entire device.

6.6.1 CONFIGURATION - 20H

Bit 7 - TIMEOUT - Enables the timeout and idle functionality of the SMBus protocol.

- '0' (default for Functional Revision C) - The SMBus timeout and idle functionality are disabled. The SMBus interface will not time out if the clock line is held low. Likewise, it will not reset if both the data and clock lines are held high for longer than 200us. This is used for I²C compliance.
- '1' (default for Functional Revision B) - The SMBus timeout and idle functionality are enabled. The SMBus interface will time out if the clock line is held low for longer than 30ms. Likewise, it will reset if both the data and clock lines are held high for longer than 200us.

Bit 5 - DIS_DIG_NOISE - Determines whether the digital noise threshold (see [Section 6.19, "Sensor Input Noise Threshold Register"](#)) is used by the device. Setting this bit disables the feature.

- '0' - The digital noise threshold is used. If a delta count value exceeds the noise threshold but does not exceed the touch threshold, the sample is discarded and not used for the automatic re-calibration routine.
- '1' (default) - The noise threshold is disabled. Any delta count that is less than the touch threshold is used for the automatic re-calibration routine.

Bit 4 - DIS_ANA_NOISE - Determines whether the analog noise filter is enabled. Setting this bit disables the feature.

- '0' (default) - If low frequency noise is detected by the analog block, the delta count on the corresponding channel is set to 0. Note that this does not require that Noise Status bits be set.
- '1' - A touch is not blocked even if low frequency noise is detected.

Bit 3 - MAX_DUR_EN - Determines whether the maximum duration recalibration is enabled.

- '0' (default) - The maximum duration recalibration functionality is disabled. A touch may be held indefinitely and no re-calibration will be performed on any sensor input.
- '1' - The maximum duration recalibration functionality is enabled. If a touch is held for longer than the MAX_DUR bit settings, then the re-calibration routine will be restarted (see [Section 6.8](#)).

6.6.2 CONFIGURATION 2 - 44H

Bit 6 - ALT_POL - Determines the ALERT# pin polarity and behavior.

- '0' - The ALERT# pin is active high and push-pull.
- '1' (default) - The ALERT# pin is active low and open drain.

Bit 5 - BLK_PWR_CTRL - Determines whether the device will reduce power consumption while waiting between conversion time completion and the end of the polling cycle.

- '0' (default) - The device will always power down as much as possible during the time between the end of the last conversion and the end of the polling cycle.
- '1' - The device will not power down the Cap Sensor during the time between the end of the last conversion and the end of the polling cycle.

Bit 3 - SHOW_RF_NOISE - Determines whether the Noise Status bits will show RF Noise as the only input source.

- '0' (default) - The Noise Status registers will show both RF noise and low frequency EMI noise if either is detected on a capacitive touch sensor input.
- '1' - The Noise Status registers will only show RF noise if it is detected on a capacitive touch sensor input. EMI

noise will still be detected and touches will be blocked normally; however, the status bits will not be updated.

Bit 2 - DIS_RF_NOISE - Determines whether the RF noise filter is enabled. Setting this bit disables the feature.

- '0' (default) - If RF noise is detected by the analog block, the delta count on the corresponding channel is set to 0. Note that this does not require that Noise Status bits be set.
- '1' - A touch is not blocked even if RF noise is detected.

Bit 0 - INT_REL_n - Controls the interrupt behavior when a release is detected on a button.

- '0' (default) - An interrupt is generated when a press is detected and again when a release is detected and at the repeat rate (if enabled - see [Section 6.13](#)).
- '1' - An interrupt is generated when a press is detected and at the repeat rate but not when a release is detected.

6.7 Sensor Input Enable Registers

TABLE 6-11: SENSOR INPUT ENABLE REGISTERS

ADDR	R/W	Register	B7	B6	B5	B4	B3	B2	B1	B0	Default
21h	R/W	Sensor Input Enable	-	-	CS6_EN	CS5_EN	CS4_EN	CS3_EN	CS2_EN	CS1_EN	3Fh

The Sensor Input Enable registers determine whether a capacitive touch sensor input is included in the sampling cycle. The length of the sampling cycle is not affected by the number of sensor inputs measured.

Bit 5 - CS6_EN - Enables the CS6 input to be included during the sampling cycle.

- '0' - The CS6 input is not included in the sampling cycle.
- '1' (default) - The CS6 input is included in the sampling cycle.

Bit 4 - CS5_EN - Enables the CS5 input to be included during the sampling cycle.

Bit 3 - CS4_EN - Enables the CS4 input to be included during the sampling cycle.

Bit 2 - CS3_EN - Enables the CS3 input to be included during the sampling cycle.

Bit 1 - CS2_EN - Enables the CS2 input to be included during the sampling cycle.

Bit 0 - CS1_EN - Enables the CS1 input to be included during the sampling cycle.

6.8 Sensor Input Configuration Register

TABLE 6-12: SENSOR INPUT CONFIGURATION REGISTER

ADDR	R/W	Register	B7	B6	B5	B4	B3	B2	B1	B0	Default
22h	R/W	Sensor Input Configuration	MAX_DUR[3:0]				RPT_RATE[3:0]				A4h

The Sensor Input Configuration Register controls timings associated with the Capacitive sensor inputs 1 - 6.

Bits 7 - 4 - MAX_DUR[3:0] - (default 1010b) - Determines the maximum time that a sensor pad is allowed to be touched until the capacitive touch sensor input is recalibrated, as shown in [Table 6-13](#).

TABLE 6-13: MAX_DUR BIT DECODE

MAX_DUR[3:0]				Time Before Recalibration
3	2	1	0	
0	0	0	0	560ms
0	0	0	1	840ms
0	0	1	0	1120ms
0	0	1	1	1400ms
0	1	0	0	1680ms
0	1	0	1	2240ms
0	1	1	0	2800ms

CAP1106

TABLE 6-13: MAX_DUR BIT DECODE (CONTINUED)

MAX_DUR[3:0]				Time Before Recalibration
3	2	1	0	
	1	1	1	3360ms
1	0	0	0	3920ms
1	0	0	1	4480ms
1	0	1	0	5600ms (default)
1	0	1	1	6720ms
1	1	0	0	7840ms
1	1	0	1	8906ms
1	1	1	0	10080ms
1	1	1	1	11200ms

Bits 3 - 0 - RPT_RATE[3:0] - (default 0100b) Determines the time duration between interrupt assertions when auto repeat is enabled. The resolution is 35ms the range is from 35ms to 560ms as shown in [Table 6-14](#).

TABLE 6-14: RPT_RATE BIT DECODE

RPT_RATE[3:0]				Interrupt Repeat RATE
3	2	1	0	
0	0	0	0	35ms
0	0	0	1	70ms
0	0	1	0	105ms
0	0	1	1	140ms
0	1	0	0	175ms (default)
0	1	0	1	210ms
0	1	1	0	245ms
0	1	1	1	280ms
1	0	0	0	315ms
1	0	0	1	350ms
1	0	1	0	385ms
1	0	1	1	420ms
1	1	0	0	455ms
1	1	0	1	490ms
1	1	1	0	525ms
1	1	1	1	560ms

6.9 Sensor Input Configuration 2 Register

TABLE 6-15: SENSOR INPUT CONFIGURATION 2 REGISTER

ADDR	R/W	Register	B7	B6	B5	B4	B3	B2	B1	B0	Default
23h	R/W	Sensor Input Configuration 2	-	-	-	-	M_PRESS[3:0]			07h	

Bits 3 - 0 - M_PRESS[3:0] - (default 0111b) - Determines the minimum amount of time that sensor inputs configured to use auto repeat must detect a sensor pad touch to detect a “press and hold” event. If the sensor input detects a touch for longer than the M_PRESS[3:0] settings, a “press and hold” event is detected. If a sensor input detects a touch for less than or equal to the M_PRESS[3:0] settings, a touch event is detected.

The resolution is 35ms the range is from 35ms to 560ms as shown in [Table 6-16](#).

TABLE 6-16: M_PRESS BIT DECODE

M_PRESS[3:0]				M_PRESS SETTINGS
3	2	1	0	
0	0	0	0	35ms
0	0	0	1	70ms
0	0	1	0	105ms
0	0	1	1	140ms
0	1	0	0	175ms
0	1	0	1	210ms
0	1	1	0	245ms
0	1	1	1	280ms (default)
1	0	0	0	315ms
1	0	0	1	350ms
1	0	1	0	385ms
1	0	1	1	420ms
1	1	0	0	455ms
1	1	0	1	490ms
1	1	1	0	525ms
1	1	1	1	560ms

6.10 Averaging and Sampling Configuration Register

TABLE 6-17: AVERAGING AND SAMPLING CONFIGURATION REGISTER

ADDR	R/W	Register	B7	B6	B5	B4	B3	B2	B1	B0	Default
24h	R/W	Averaging and Sampling Config		AVG[2:0]			SAMP_TIME[1:0]		CYCLE_TIME [1:0]		39h

The Averaging and Sampling Configuration register controls the number of samples taken and the total sensor input cycle time for all active sensor inputs while the device is functioning in Active state.

Bits 6 - 4 - AVG[2:0] - Determines the number of samples that are taken for all active channels during the sensor cycle as shown in Table 6-18. All samples are taken consecutively on the same channel before the next channel is sampled and the result is averaged over the number of samples measured before updating the measured results.

For example, if CS1, CS2, and CS3 are sampled during the sensor cycle, and the AVG[2:0] bits are set to take 4 samples per channel, then the full sensor cycle will be: CS1, CS1, CS1, CS1, CS2, CS2, CS2, CS2, CS3, CS3, CS3, CS3.

TABLE 6-18: AVG BIT DECODE

AVG[2:0]			Number of Samples Taken per Measurement
2	1	0	
0	0	0	1
0	0	1	2
0	1	0	4
0	1	1	8 (default)
1	0	0	16
1	0	1	32
1	1	0	64
1	1	1	128

Bits 3 - 2 - SAMP_TIME[1:0] - Determines the time to take a single sample as shown in Table 6-19.

TABLE 6-19: SAMP_TIME BIT DECODE

SAMP_TIME[1:0]		Sample Time
1	0	
0	0	320us
0	1	640us
1	0	1.28ms (default)
1	1	2.56ms

Bits 1 - 0 - CYCLE_TIME[1:0] - Determines the overall cycle time for all measured channels during normal operation as shown in Table 6-20. All measured channels are sampled at the beginning of the cycle time. If additional time is remaining, then the device is placed into a lower power state for the remaining duration of the cycle.

TABLE 6-20: CYCLE_TIME BIT DECODE

CYCLE_TIME[1:0]		Overall Cycle Time
1	0	
0	0	35ms
0	1	70ms (default)
1	0	105ms
1	1	140ms

APPLICATION NOTE: The programmed cycle time is only maintained if the total averaging time for all samples is less than the programmed cycle. The AVG[2:0] bits will take priority so that if more samples are required than would normally be allowed during the cycle time, the cycle time will be extended as necessary to accommodate the number of samples to be measured.

6.11 Calibration Activate Register

TABLE 6-21: CALIBRATION ACTIVATE REGISTER

ADDR	R/W	Register	B7	B6	B5	B4	B3	B2	B1	B0	Default
26h	R/W	Calibration Activate	-	-	CS6_CAL	CS5_CAL	CS4_CAL	CS3_CAL	CS2_CAL	CS1_CAL	00h

The Calibration Activate register forces the respective sensor inputs to be re-calibrated affecting both the analog and digital blocks. During the re-calibration routine, the sensor inputs will not detect a press for up to 600ms and the Sensor Input Base Count register values will be invalid. During this time, any press on the corresponding sensor pads will invalidate the re-calibration. When finished, the CALX[9:0] bits will be updated (see Section 6.25).

When the corresponding bit is set, the device will perform the calibration and the bit will be automatically cleared once the re-calibration routine has finished.

Bit 5 - CS6_CAL - When set, the CS6 input is re-calibrated. This bit is automatically cleared once the sensor input has been re-calibrated successfully.

Bit 4 - CS5_CAL - When set, the CS5 input is re-calibrated. This bit is automatically cleared once the sensor input has been re-calibrated successfully.

Bit 3 - CS4_CAL - When set, the CS4 input is re-calibrated. This bit is automatically cleared once the sensor input has been re-calibrated successfully.

Bit 2 - CS3_CAL - When set, the CS3 input is re-calibrated. This bit is automatically cleared once the sensor input has been re-calibrated successfully.

Bit 1 - CS2_CAL - When set, the CS2 input is re-calibrated. This bit is automatically cleared once the sensor input has been re-calibrated successfully.

Bit 0 - CS1_CAL - When set, the CS1 input is re-calibrated. This bit is automatically cleared once the sensor input has been re-calibrated successfully.

6.12 Interrupt Enable Register

TABLE 6-22: INTERRUPT ENABLE REGISTER

ADDR	R/W	Register	B7	B6	B5	B4	B3	B2	B1	B0	Default
27h	R/W	Interrupt Enable	-	-	CS6_INT_EN	CS5_INT_EN	CS4_INT_EN	CS3_INT_EN	CS2_INT_EN	CS1_INT_EN	3Fh

The Interrupt Enable register determines whether a sensor pad touch or release (if enabled) causes the interrupt pin to be asserted.

Bit 5 - CS6_INT_EN - Enables the interrupt pin to be asserted if a touch is detected on CS6 (associated with the CS6 status bit).

- '0' - The interrupt pin will not be asserted if a touch is detected on CS6 (associated with the CS6 status bit).
- '1' (default) - The interrupt pin will be asserted if a touch is detected on CS6 (associated with the CS6 status bit).

Bit 4 - CS5_INT_EN - Enables the interrupt pin to be asserted if a touch is detected on CS5 (associated with the CS5 status bit).

Bit 3 - CS4_INT_EN - Enables the interrupt pin to be asserted if a touch is detected on CS4 (associated with the CS4 status bit).

Bit 2 - CS3_INT_EN - Enables the interrupt pin to be asserted if a touch is detected on CS3 (associated with the CS3 status bit).

Bit 1 - CS2_INT_EN - Enables the interrupt pin to be asserted if a touch is detected on CS2 (associated with the CS2 status bit).

Bit 0 - CS1_INT_EN - Enables the interrupt pin to be asserted if a touch is detected on CS1 (associated with the CS1 status bit).

6.13 Repeat Rate Enable Register

TABLE 6-23: REPEAT RATE ENABLE REGISTER

ADDR	R/W	Register	B7	B6	B5	B4	B3	B2	B1	B0	Default
28h	R/W	Repeat Rate Enable	-	-	CS6_RPT_EN	CS5_RPT_EN	CS4_RPT_EN	CS3_RPT_EN	CS2_RPT_EN	CS1_RPT_EN	3Fh

The Repeat Rate Enable register enables the repeat rate of the sensor inputs as described in [Section 5.3.1](#).

Bit 5 - CS6_RPT_EN - Enables the repeat rate for capacitive touch sensor input 6.

- '0' - The repeat rate for CS6 is disabled. It will only generate an interrupt when a touch is detected and when a release is detected no matter how long the touch is held for.
- '1' (default) - The repeat rate for CS6 is enabled. In the case of a "touch" event, it will generate an interrupt when a touch is detected and a release is detected (as determined by the INT_REL_n bit - see [Section 6.6](#)). In the case of a "press and hold" event, it will generate an interrupt when a touch is detected and at the repeat rate so long as the touch is held.

Bit 4 - CS5_RPT_EN - Enables the repeat rate for capacitive touch sensor input 5.

Bit 3 - CS4_RPT_EN - Enables the repeat rate for capacitive touch sensor input 4.

Bit 2 - CS3_RPT_EN - Enables the repeat rate for capacitive touch sensor input 3.

Bit 1 - CS2_RPT_EN - Enables the repeat rate for capacitive touch sensor input 2.

Bit 0 - CS1_RPT_EN - Enables the repeat rate for capacitive touch sensor input 1.

CAP1106

6.14 Multiple Touch Configuration Register

TABLE 6-24: MULTIPLE TOUCH CONFIGURATION

ADDR	R/W	Register	B7	B6	B5	B4	B3	B2	B1	B0	Default
2Ah	R/W	Multiple Touch Config	MULT_BLK_EN	-	-	-	B_MULT_T[1:0]	-	-	-	80h

The Multiple Touch Configuration register controls the settings for the multiple touch detection circuitry. These settings determine the number of simultaneous buttons that may be pressed before additional buttons are blocked and the MULT status bit is set.

Bit 7 - MULT_BLK_EN - Enables the multiple button blocking circuitry.

- '0' - The multiple touch circuitry is disabled. The device will not block multiple touches.
- '1' (default) - The multiple touch circuitry is enabled. The device will flag the number of touches equal to programmed multiple touch threshold and block all others. It will remember which sensor inputs are valid and block all others until that sensor pad has been released. Once a sensor pad has been released, the N detected touches (determined via the cycle order of CS1 - CS6) will be flagged and all others blocked.

Bits 3 - 2 - B_MULT_T[1:0] - Determines the number of simultaneous touches on all sensor pads before a Multiple Touch Event is detected and sensor inputs are blocked. The bit decode is given by [Table 6-25](#).

TABLE 6-25: B_MULT_T BIT DECODE

B_MULT_T[1:0]		Number of Simultaneous Touches
1	0	
0	0	1 (default)
0	1	2
1	0	3
1	1	4

6.15 Multiple Touch Pattern Configuration Register

TABLE 6-26: MULTIPLE TOUCH PATTERN CONFIGURATION

ADDR	R/W	Register	B7	B6	B5	B4	B3	B2	B1	B0	Default
2Bh	R/W	Multiple Touch Pattern Config	MTP_EN	-	-		MTP_TH[1:0]		COMP_PTRN	MTP_ALERT	00h

The Multiple Touch Pattern Configuration register controls the settings for the multiple touch pattern detection circuitry. This circuitry works like the multiple touch detection circuitry with the following differences:

1. The detection threshold is a percentage of the touch detection threshold as defined by the MTP_TH[1:0] bits whereas the multiple touch circuitry uses the touch detection threshold.
2. The MTP detection circuitry either will detect a specific pattern of sensor inputs as determined by the Multiple Touch Pattern register settings or it will use the Multiple Touch Pattern register settings to determine a minimum number of sensor inputs that will cause the MTP circuitry to flag an event. When using pattern recognition mode, if all of the sensor inputs set by the Multiple Touch Pattern register have a delta count greater than the MTP threshold or have their corresponding Noise Flag Status bits set, the MTP bit will be set. When using the absolute number mode, if the number of sensor inputs with thresholds above the MTP threshold or with Noise Flag Status bits set is equal to or greater than this number, the MTP bit will be set.
3. When an MTP event occurs, all touches are blocked and an interrupt is generated.
4. All sensor inputs will remain blocked so long as the requisite number of sensor inputs are above the MTP threshold or have Noise Flag Status bits set. Once this condition is removed, touch detection will be restored. Note that the MTP status bit is only cleared by writing a '0' to the INT bit once the condition has been removed.

Bit 7 - MTP_EN - Enables the multiple touch pattern detection circuitry.

- '0' (default) - The MTP detection circuitry is disabled.
- '1' - The MTP detection circuitry is enabled.

Bits 3-2 - MTP_TH[1:0] - Determine the MTP threshold, as shown in Table 6-27. This threshold is a percentage of sensor input threshold (see Section 6.18, "Sensor Input Threshold Registers") when the device is in the Fully Active state or of the standby threshold (see Section 6.23, "Standby Threshold Register") when the device is in the Standby state.

TABLE 6-27: MTP_TH BIT DECODE

MTP_TH[1:0]		Threshold Divide Setting
1	0	
0	0	12.5% (default)
0	1	25%
1	0	37.5%
1	1	100%

Bit 1 - COMP_PTRN - Determines whether the MTP detection circuitry will use the Multiple Touch Pattern register as a specific pattern of sensor inputs or as an absolute number of sensor inputs.

- '0' (default) - The MTP detection circuitry will use the Multiple Touch Pattern register bit settings as an absolute minimum number of sensor inputs that must be above the threshold or have Noise Flag Status bits set. The number will be equal to the number of bits set in the register.
- '1' - The MTP detection circuitry will use pattern recognition. Each bit set in the Multiple Touch Pattern register indicates a specific sensor input that must have a delta count greater than the MTP threshold or have a Noise Flag Status bit set. If the criteria are met, the MTP status bit will be set.

Bit 0 - MTP_ALERT - Enables an interrupt if an MTP event occurs. In either condition, the MTP status bit will be set.

- '0' (default) - If an MTP event occurs, the ALERT# pin is not asserted.
- '1' - If an MTP event occurs, the ALERT# pin will be asserted.

6.16 Multiple Touch Pattern Register

TABLE 6-28: MULTIPLE TOUCH PATTERN REGISTER

ADDR	R/W	Register	B7	B6	B5	B4	B3	B2	B1	B0	Default
2Dh	R/W	Multiple Touch Pattern	-	-	CS6_PTRN	CS5_PTRN	CS4_PTRN	CS3_PTRN	CS2_PTRN	CS1_PTRN	3Fh

The Multiple Touch Pattern register acts as a pattern to identify an expected sensor input profile for diagnostics or other significant events. There are two methods for how the Multiple Touch Pattern register is used: as specific sensor inputs or number of sensor input that must exceed the MTP threshold or have Noise Flag Status bits set. Which method is used is based on the COMP_PTRN bit (see Section 6.15). The methods are described below.

1. Specific Sensor Inputs: If, during a single polling cycle, the specific sensor inputs above the MTP threshold or with Noise Flag Status bits set match those bits set in the Multiple Touch Pattern register, an MTP event is flagged.
2. Number of Sensor Inputs: If, during a single polling cycle, the number of sensor inputs with a delta count above the MTP threshold or with Noise Flag Status bits set is equal to or greater than the number of pattern bits set, an MTP event is flagged.

Bit 5 - CS6_PTRN - Determines whether CS6 is considered as part of the Multiple Touch Pattern.

- '0' - CS6 is not considered a part of the pattern.
- '1' - CS6 is considered a part of the pattern or the absolute number of sensor inputs that must have a delta count greater than the MTP threshold or have the Noise Flag Status bit set is increased by 1.

Bit 4 - CS5_PTRN - Determines whether CS5 is considered as part of the Multiple Touch Pattern.

Bit 3 - CS4_PTRN - Determines whether CS4 is considered as part of the Multiple Touch Pattern.

Bit 2 - CS3_PTRN - Determines whether CS3 is considered as part of the Multiple Touch Pattern.

CAP1106

Bit 1 - CS2_PTRN - Determines whether CS2 is considered as part of the Multiple Touch Pattern.

Bit 0 - CS1_PTRN - Determines whether CS1 is considered as part of the Multiple Touch Pattern.

6.17 Recalibration Configuration Register

TABLE 6-29: RECALIBRATION CONFIGURATION REGISTERS

ADDR	R/W	Register	B7	B6	B5	B4	B3	B2	B1	B0	Default
2Fh	R/W	Recalibration Configuration	BUT_LD_TH	NO_CLR_INTD	NO_CLR_NEG	NEG_DELTA_CNT[1:0]		CAL_CFG[2:0]			8Ah

The Recalibration Configuration register controls the automatic re-calibration routine settings as well as advanced controls to program the Sensor Input Threshold register settings.

Bit 7 - BUT_LD_TH - Enables setting all Sensor Input Threshold registers by writing to the Sensor Input 1 Threshold register.

- '0' - Each Sensor Input X Threshold register is updated individually.
- '1' (default) - Writing the Sensor Input 1 Threshold register will automatically overwrite the Sensor Input Threshold registers for all sensor inputs (Sensor Input Threshold 1 through Sensor Input Threshold 6). The individual Sensor Input X Threshold registers (Sensor Input 2 Threshold through Sensor Input 6 Threshold) can be individually updated at any time.

Bit 6 - NO_CLR_INTD - Controls whether the accumulation of intermediate data is cleared if the noise status bit is set.

- '0' (default) - The accumulation of intermediate data is cleared if the noise status bit is set.
- '1' - The accumulation of intermediate data is not cleared if the noise status bit is set.

APPLICATION NOTE: Bits 5 and 6 should both be set to the same value. Either both should be set to '0' or both should be set to '1'.

Bit 5 - NO_CLR_NEG - Controls whether the consecutive negative delta counts counter is cleared if the noise status bit is set.

- '0' (default) - The consecutive negative delta counts counter is cleared if the noise status bit is set.
- '1' - The consecutive negative delta counts counter is not cleared if the noise status bit is set.

Bits 4 - 3 - NEG_DELTA_CNT[1:0] - Determines the number of negative delta counts necessary to trigger a digital recalibration as shown in [Table 6-30](#).

TABLE 6-30: NEG_DELTA_CNT BIT DECODE

NEG_DELTA_CNT[1:0]		Number of Consecutive Negative Delta Count Values
1	0	
0	0	8
0	1	16 (default)
1	0	32
1	1	None (disabled)

Bits 2 - 0 - CAL_CFG[2:0] - Determines the update time and number of samples of the automatic re-calibration routine. The settings apply to all sensor inputs universally (though individual sensor inputs can be configured to support recalibration - see [Section 6.11](#)).

TABLE 6-31: CAL_CFG BIT DECODE

CAL_CFG[2:0]			Recalibration Samples (see Note 6-1)	Update Time (see Note 6-2)
2	1	0		
0	0	0	16	16
0	0	1	32	32

TABLE 6-31: CAL_CFG BIT DECODE (CONTINUED)

CAL_CFG[2:0]			Recalibration Samples (see Note 6-1)	Update Time (see Note 6-2)
2	1	0		
0	1	0	64	64 (default)
0	1	1	128	128
1	0	0	256	256
1	0	1	256	1024
1	1	0	256	2048
1	1	1	256	4096

Note 6-1 Recalibration Samples refers to the number of samples that are measured and averaged before the Base Count is updated however does not control the base count update period.

Note 6-2 Update Time refers to the amount of time (in polling cycle periods) that elapses before the Base Count is updated. The time will depend upon the number of channels active, the averaging setting, and the programmed cycle time.

6.18 Sensor Input Threshold Registers

TABLE 6-32: SENSOR INPUT THRESHOLD REGISTERS

ADDR	R/W	Register	B7	B6	B5	B4	B3	B2	B1	B0	Default
30h	R/W	Sensor Input 1 Threshold	-	64	32	16	8	4	2	1	40h
31h	R/W	Sensor Input 2 Threshold	-	64	32	16	8	4	2	1	40h
32h	R/W	Sensor Input 3 Threshold	-	64	32	16	8	4	2	1	40h
33h	R/W	Sensor Input 4 Threshold	-	64	32	16	8	4	2	1	40h
34h	R/W	Sensor Input 5 Threshold	-	64	32	16	8	4	2	1	40h
35h	R/W	Sensor Input 6 Threshold	-	64	32	16	8	4	2	1	40h

The Sensor Input Threshold registers store the delta threshold that is used to determine if a touch has been detected. When a touch occurs, the input signal of the corresponding sensor pad changes due to the capacitance associated with a touch. If the sensor input change exceeds the threshold settings, a touch is detected.

When the BUT_LD_TH bit is set (see Section 6.17 - bit 7), writing data to the Sensor Input 1 Threshold register will update all of the sensor input threshold registers (31h - 35h inclusive).

6.19 Sensor Input Noise Threshold Register

TABLE 6-33: SENSOR INPUT NOISE THRESHOLD REGISTER

ADDR	R/W	Register	B7	B6	B5	B4	B3	B2	B1	B0	Default
38h	R/W	Sensor Input Noise Threshold							CS_BN_TH [1:0]		01h

The Sensor Input Noise Threshold register controls the value of a secondary internal threshold to detect noise and improve the automatic recalibration routine. If a capacitive touch sensor input exceeds the Sensor Input Noise Threshold but does not exceed the sensor input threshold, it is determined to be caused by a noise spike. That sample is not used by the automatic re-calibration routine. This feature can be disabled by setting the DIS_DIG_NOISE bit.

Bits 1-0 - CS1_BN_TH[1:0] - Controls the noise threshold for all capacitive touch sensor inputs, as shown in Table 6-34. The threshold is proportional to the threshold setting.

TABLE 6-34: CSX_BN_TH BIT DECODE

CS_BN_TH[1:0]		Percent Threshold Setting
1	0	
0	0	25%
0	1	37.5% (default)
1	0	50%
1	1	62.5%

6.20 Standby Channel Register

TABLE 6-35: STANDBY CHANNEL REGISTER

ADDR	R/W	Register	B7	B6	B5	B4	B3	B2	B1	B0	Default
40h	R/W	Standby Channel	-	-	CS6_STBY	CS5_STBY	CS4_STBY	CS3_STBY	CS2_STBY	CS1_STBY	00h

The Standby Channel register controls which (if any) capacitive touch sensor inputs are active during Standby.

Bit 5 - CS6_STBY - Controls whether the CS6 channel is active in Standby.

- '0' (default) - The CS6 channel not be sampled during Standby mode.
- '1' - The CS6 channel will be sampled during Standby Mode. It will use the Standby threshold setting, and the standby averaging and sensitivity settings.

Bit 4 - CS5_STBY - Controls whether the CS5 channel is active in Standby.

Bit 3 - CS4_STBY - Controls whether the CS4 channel is active in Standby.

Bit 2 - CS3_STBY - Controls whether the CS3 channel is active in Standby.

Bit 1 - CS2_STBY - Controls whether the CS2 channel is active in Standby.

Bit 0 - CS1_STBY - Controls whether the CS1 channel is active in Standby.

6.21 Standby Configuration Register

TABLE 6-36: STANDBY CONFIGURATION REGISTER

ADDR	R/W	Register	B7	B6	B5	B4	B3	B2	B1	B0	Default
41h	R/W	Standby Configuration	AVG_SUM	STBY_AVG[2:0]		STBY_SAMP_TIME[1:0]		STBY_CY_TIME[1:0]			39h

The Standby Configuration register controls averaging and cycle time for those sensor inputs that are active in Standby. This register is useful for detecting proximity on a small number of sensor inputs as it allows the user to change averaging and sample times on a limited number of sensor inputs and still maintain normal functionality in the fully active state.

Bit 7 - AVG_SUM - Determines whether the active sensor inputs will average the programmed number of samples or whether they will accumulate for the programmed number of samples.

- '0' - (default) - The active sensor input delta count values will be based on the average of the programmed number of samples when compared against the threshold.
- '1' - The active sensor input delta count values will be based on the summation of the programmed number of samples when compared against the threshold. This bit should only be set when performing proximity detection as a physical touch will overflow the delta count registers and may result in false readings.

Bits 6 - 4 - STBY_AVG[2:0] - Determines the number of samples that are taken for all active channels during the sensor cycle as shown in [Table 6-37](#). All samples are taken consecutively on the same channel before the next channel is sampled and the result is averaged over the number of samples measured before updating the measured results.

TABLE 6-37: STBY_AVG BIT DECODE

STBY_AVG[2:0]			Number of Samples Taken per Measurement
2	1	0	
0	0	0	1
0	0	1	2
0	1	0	4
0	1	1	8 (default)
1	0	0	16
1	0	1	32
1	1	0	64
1	1	1	128

Bit 3-2 - STBY_SAMP_TIME[1:0] - Determines the time to take a single sample when the device is in Standby as shown in Table 6-38.

TABLE 6-38: STBY_SAMP_TIME BIT DECODE

STBY_SAMP_TIME[1:0]		Sampling Time
1	0	
0	0	320us
0	1	640us
1	0	1.28ms (default)
1	1	2.56ms

Bits 1 - 0 - STBY_CY_TIME[2:0] - Determines the overall cycle time for all measured channels during standby operation as shown in Table 6-39. All measured channels are sampled at the beginning of the cycle time. If additional time is remaining, the device is placed into a lower power state for the remaining duration of the cycle.

TABLE 6-39: STBY_CY_TIME BIT DECODE

STBY_CY_TIME[1:0]		Overall Cycle Time
1	0	
0	0	35ms
0	1	70ms (default)
1	0	105ms
1	1	140ms

APPLICATION NOTE: The programmed cycle time is only maintained if the total averaging time for all samples is less than the programmed cycle. The STBY_AVG[2:0] bits will take priority so that if more samples are required than would normally be allowed during the cycle time, the cycle time will be extended as necessary to accommodate the number of samples to be measured.

6.22 Standby Sensitivity Register

TABLE 6-40: STANDBY SENSITIVITY REGISTER

ADDR	R/W	Register	B7	B6	B5	B4	B3	B2	B1	B0	Default
42h	R/W	Standby Sensitivity	-	-	-	-	-	STBY_SENSE[2:0]			02h

The Standby Sensitivity register controls the sensitivity for sensor inputs that are active in Standby.

CAP1106

Bits 2 - 0 - STBY_SENSE[2:0] - Controls the sensitivity for sensor inputs that are active in Standby. The sensitivity settings act to scale the relative delta count value higher or lower based on the system parameters. A setting of 000b is the most sensitive while a setting of 111b is the least sensitive. At the more sensitive settings, touches are detected for a smaller delta C corresponding to a “lighter” touch. These settings are more sensitive to noise however and a noisy environment may flag more false touches than higher sensitivity levels.

APPLICATION NOTE: A value of 128x is the most sensitive setting available. At the most sensitivity settings, the MSB of the Delta Count register represents 64 out of ~25,000 which corresponds to a touch of approximately 0.25% of the base capacitance (or a ΔC of 25fF from a 10pF base capacitance). Conversely a value of 1x is the least sensitive setting available. At these settings, the MSB of the Delta Count register corresponds to a delta count of 8192 counts out of ~25,000 which corresponds to a touch of approximately 33% of the base capacitance (or a ΔC of 3.33pF from a 10pF base capacitance).

TABLE 6-41: STBY_SENSE BIT DECODE

STBY_SENSE[2:0]			Sensitivity Multiplier
2	1	0	
0	0	0	128x (most sensitive)
0	0	1	64x
0	1	0	32x (default)
0	1	1	16x
1	0	0	8x
1	0	1	4x
1	1	0	2x
1	1	1	1x - (least sensitive)

6.23 Standby Threshold Register

TABLE 6-42: STANDBY THRESHOLD REGISTER

ADDR	R/W	Register	B7	B6	B5	B4	B3	B2	B1	B0	Default
43h	R/W	Standby Threshold	-	64	32	16	8	4	2	1	40h

The Standby Threshold register stores the delta threshold that is used to determine if a touch has been detected. When a touch occurs, the input signal of the corresponding sensor pad changes due to the capacitance associated with a touch. If the sensor input change exceeds the threshold settings, a touch is detected.

6.24 Sensor Input Base Count Registers

TABLE 6-43: SENSOR INPUT BASE COUNT REGISTERS

ADDR	R/W	Register	B7	B6	B5	B4	B3	B2	B1	B0	Default
50h	R	Sensor Input 1 Base Count	128	64	32	16	8	4	2	1	C8h
51h	R	Sensor Input 2 Base Count	128	64	32	16	8	4	2	1	C8h
52h	R	Sensor Input 3 Base Count	128	64	32	16	8	4	2	1	C8h
53h	R	Sensor Input 4 Base Count	128	64	32	16	8	4	2	1	C8h
54h	R	Sensor Input 5 Base Count	128	64	32	16	8	4	2	1	C8h
55h	R	Sensor Input 6 Base Count	128	64	32	16	8	4	2	1	C8h

The Sensor Input Base Count registers store the calibrated “Not Touched” input value from the capacitive touch sensor inputs. These registers are periodically updated by the re-calibration routine.

The routine uses an internal adder to add the current count value for each reading to the sum of the previous readings until sample size has been reached. At this point, the upper 16 bits are taken and used as the Sensor Input Base Count. The internal adder is then reset and the re-calibration routine continues.

The data presented is determined by the BASE_SHIFT[3:0] bits (see [Section 6.5](#)).

6.25 Sensor Input Calibration Registers

TABLE 6-44: SENSOR INPUT CALIBRATION REGISTERS

ADDR	Register	R/W	B7	B6	B5	B4	B3	B2	B1	B0	Default
B1h	Sensor Input 1 Calibration	R	CAL1_9	CAL1_8	CAL1_7	CAL1_6	CAL1_5	CAL1_4	CAL1_3	CAL1_2	00h
B2h	Sensor Input 2 Calibration	R	CAL2_9	CAL2_8	CAL2_7	CAL2_6	CAL2_5	CAL2_4	CAL2_3	CAL2_2	00h
B3h	Sensor Input 3 Calibration	R	CAL3_9	CAL3_8	CAL3_7	CAL3_6	CAL3_5	CAL3_4	CAL3_3	CAL3_2	00h
B4h	Sensor Input 4 Calibration	R	CAL4_9	CAL4_8	CAL4_7	CAL4_6	CAL4_5	CAL4_4	CAL4_3	CAL4_2	00h
B5h	Sensor Input 5 Calibration	R	CAL5_9	CAL5_8	CAL5_7	CAL5_6	CAL5_5	CAL5_4	CAL5_3	CAL5_2	00h
B6h	Sensor Input 6 Calibration	R	CAL6_9	CAL6_8	CAL6_7	CAL6_6	CAL6_5	CAL6_4	CAL6_3	CAL6_2	00h
B9h	Sensor Input Calibration LSB 1	R	CAL4_1	CAL4_0	CAL3_1	CAL3_0	CAL2_1	CAL2_0	CAL1_1	CAL1_0	00h
BAh	Sensor Input Calibration LSB 2	R	-	-	-	-	CAL6_1	CAL6_0	CAL5_1	CAL5_0	00h

The Sensor Input Calibration registers hold the 10-bit value that represents the last calibration value.

6.26 Product ID Register

TABLE 6-45: PRODUCT ID REGISTER

ADDR	R/W	Register	B7	B6	B5	B4	B3	B2	B1	B0	Default
FDh	R	Product ID CAP1106	0	1	0	1	0	1	0	1	55h

The Product ID register stores a unique 8-bit value that identifies the device.

6.27 Manufacturer ID Register

TABLE 6-46: VENDOR ID REGISTER

ADDR	R/W	Register	B7	B6	B5	B4	B3	B2	B1	B0	Default
FEh	R	Manufacturer ID	0	1	0	1	1	1	0	1	5Dh

The Vendor ID register stores an 8-bit value that represents Microchip.

CAP1106

6.28 Revision Register

TABLE 6-47: REVISION REGISTER

ADDR	R/W	Register	B7	B6	B5	B4	B3	B2	B1	B0	Default
FFh	R	Revision	1	0	0	0	0	0	1	1	83h

The Revision register stores an 8-bit value that represents the part revision.

7.0 PACKAGE INFORMATION

7.1 CAP1106 Package Drawings

FIGURE 7-1: 10-Pin DFN 3mm x 3mm Package Drawings (1 of 2)

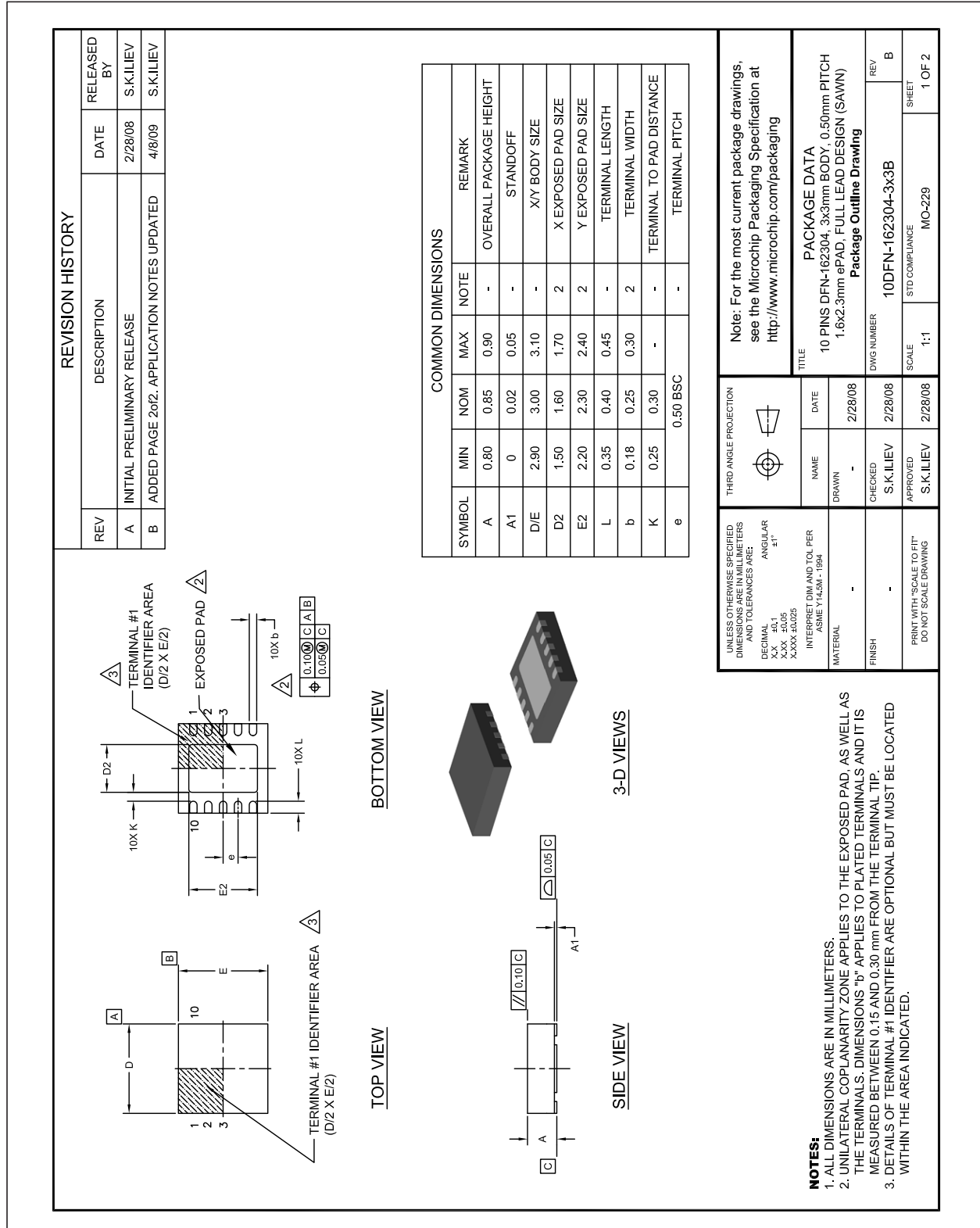
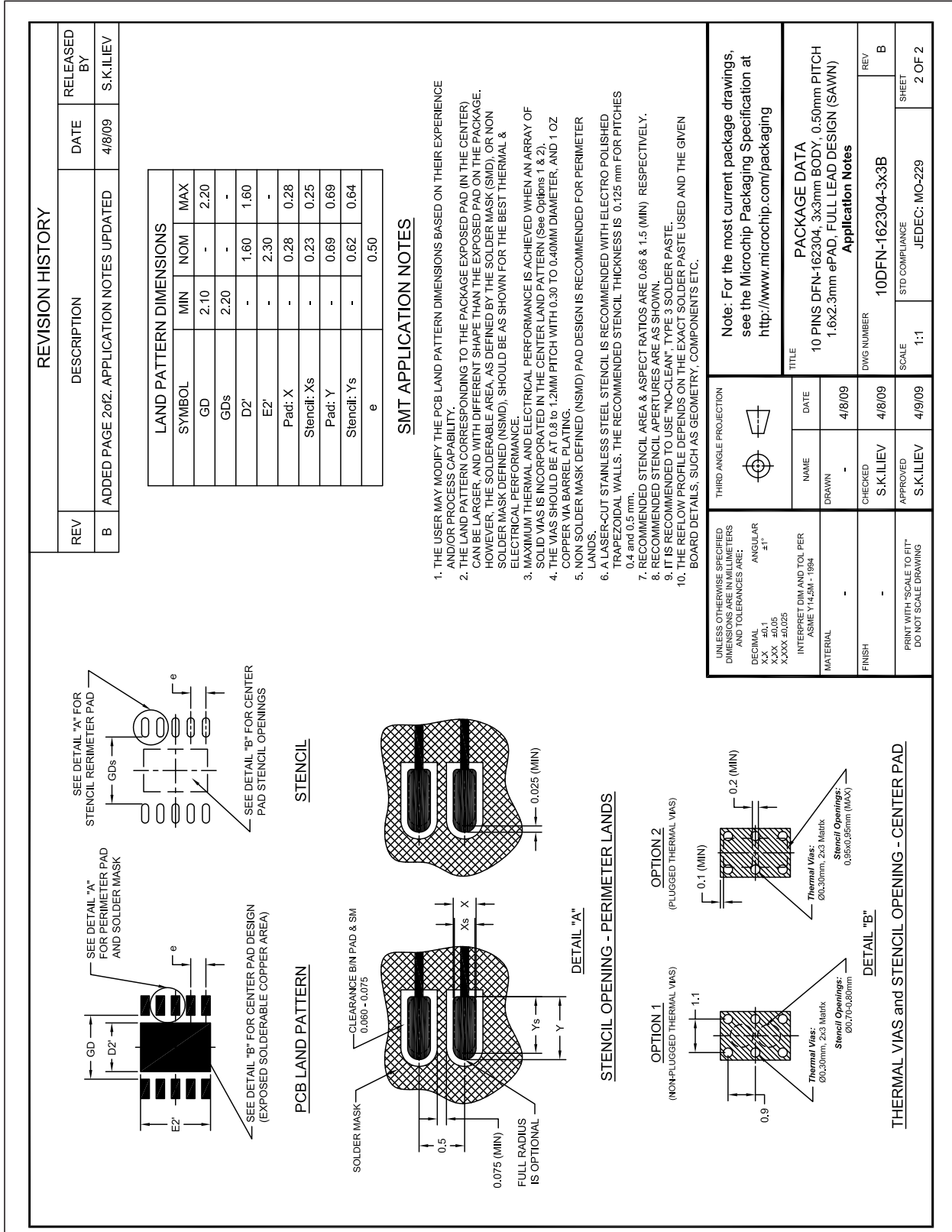

FIGURE 7-2: 10-Pin DFN 3mm x 3mm Package Drawings (2 of 2)



7.2 Package Marking

FIGURE 7-3: CAP1106 Package Markings

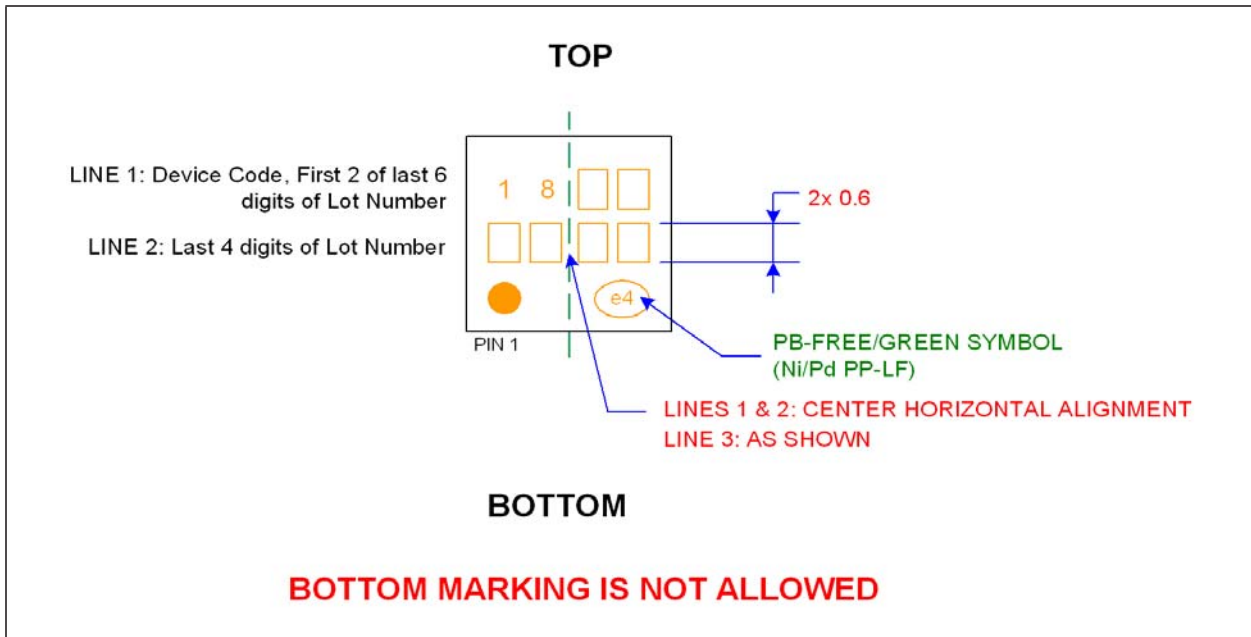
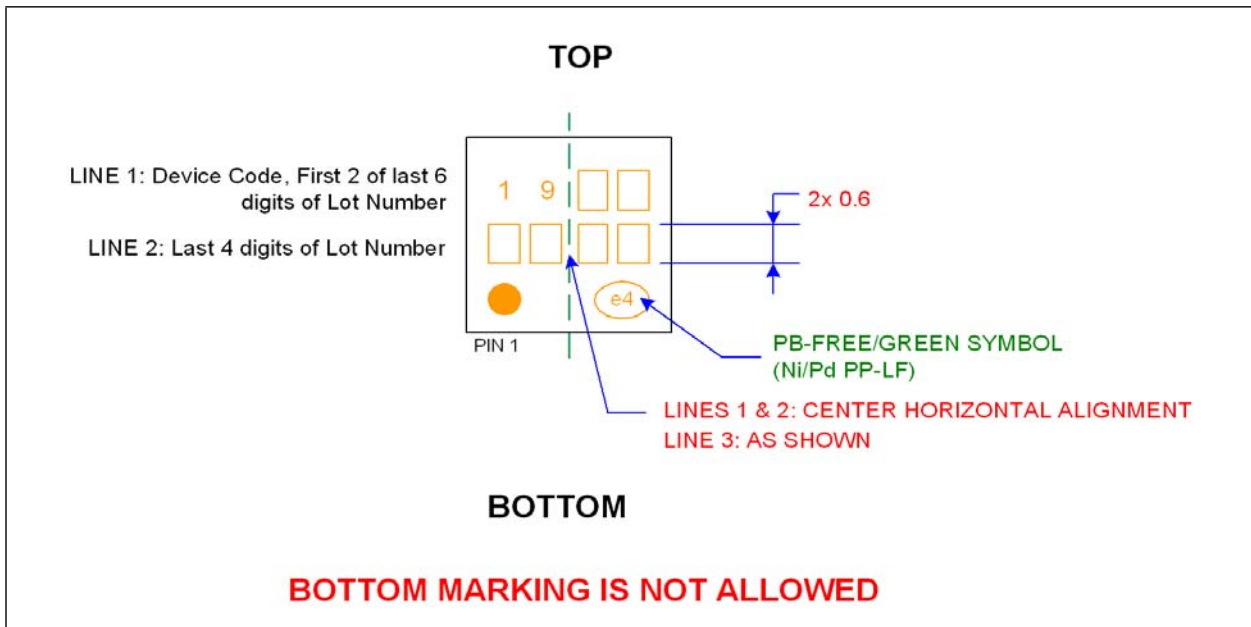

FIGURE 7-4: CAP1106 with BC-Link Support Package Markings



CAP1106

APPENDIX A: DEVICE DELTA

A.1 Delta from CAP1006 to CAP1106

1. Updated circuitry to improve power supply rejection.
2. Added Multiple Touch Pattern detection circuitry. See [Section 6.15, "Multiple Touch Pattern Configuration Register"](#).
3. Added General Status register to flag Multiple touches, Multiple Touch Pattern issues and general touch detections. See [Section 6.2, "Status Registers"](#).
4. Added bits 6 and 5 to the Recalibration Configuration register (2Dh - see [Section 6.17, "Recalibration Configuration Register"](#)). These bits control whether the accumulation of intermediate data and the consecutive negative delta counts counter are cleared when the noise status bit is set.
5. Added Configuration 2 register for noise detection controls and control to interrupt on press but not on release. Added control to change alert pin polarity. See [Section 6.6, "Configuration Registers"](#).
6. Updated Deep Sleep behavior so that device does not clear DSLEEP bit on received communications but will wake to communicate.
7. Register delta:

Table A.1 Register Delta From CAP1006 to CAP1106

Address	Register Delta	Delta	Default
00h Page 20	Changed - Main Status / Control	added bits 7-6 to control gain	00h
02h Page 21	New - General Status	new register to store MTP, MULT, and general TOUCH bits	00h
44h Page 24	New - Configuration 2	new register to control alert polarity, and noise detection, and interrupt on release	00h
24h Page 27	Changed - Averaging Control	updated register bits - moved SAMP_AVG[2:0] bits and added SAMP_TIME bit 1. Default changed	39h
2Bh Page 30	New - Multiple Touch Pattern Configuration	new register for Multiple Touch Pattern configuration - enable and threshold settings	80h
2Dh Page 31	New - Multiple Touch Pattern Register	new register for Multiple Touch Pattern detection circuitry - pattern or number of sensor inputs	3Fh
2Fh Page 32	Changed - Recalibration Configuration	updated register - updated CAL_CFG bit decode to add a 128 averages setting and removed highest time setting. Default changed. Added bit 6 NO_CLR_INTD and bit 5 NO_CLR_NEG.	8Ah
38h Page 33	Changed - Sensor Input Noise Threshold	updated register bits - removed bits 7 - 3 and consolidated all controls into bits 1 - 0. These bits will set the noise threshold for all channels. Default changed	01h
39h	Removed - Noise Threshold Register 2	removed register	n/a
41h Page 34	Changed - Standby Configuration	updated register bits - moved STBY_AVG[2:0] bits and added STBY_TIME bit 1. Default changed	39h
FDh Page 37	Changed - Product ID	Changed bit decode for CAP1106	55h

APPENDIX B: DATA SHEET REVISION HISTORY

Revision	Section/Figure/Entry	Correction
REV A	REV A replaces previous SMSC version Rev. 1.32 (01-05-12)	
Rev. 1.32 (01-05-12)	Table 3-2, "Electrical Specifications"	Added conditions for $t_{HD:DAT}$.
	Section 4.2.7, "SMBus and I2C Compatibility"	Renamed from "SMBus and I2C Compliance." First paragraph, added last sentence: "For information on using the CAP1106 in an I ² C system, refer to SMSC AN 14.0 SMSC Dedicated Slave Devices in I ² C Systems." Added: CAP1106 supports I ² C fast mode at 400kHz. This covers the SMBus max time of 100kHz.
	Section 6.4, "Sensor Input Delta Count Registers"	Changed negative value cap from FFh to 80h.
Rev. 1.31 (08-18-11)	Section 4.3.3, "SMBus Send Byte"	Added an application note: The Send Byte protocol is not functional in Deep Sleep (i.e., DSLEEP bit is set).
	Section 4.3.4, "SMBus Receive Byte"	Added an application note: The Receive Byte protocol is not functional in Deep Sleep (i.e., DSLEEP bit is set).
	Section 6.2, "Status Registers"	Removed RESET as bit 3 in register 02h.
Rev. 1.3 (05-18-11)	Section 6.28, "Revision Register"	Updated revision ID from 82h to 83h.
	Section 6.2, "Status Registers"	Added RESET as bit 3 in register 02h.
Rev. 1.2 (02-10-11)	Section A.8, "Delta from Rev B (Mask B0) to Rev C (Mask B1)"	Added.
	Table 3-2, "Electrical Specifications"	PSR improvements made in functional revision B. Changed PSR spec from ± 100 typ and ± 200 max counts / V to ± 3 and ± 10 counts / V. Conditions updated.
	Section 5.2.2, "Recalibrating Sensor Inputs"	Added more detail with subheadings for each type of recalibration.
	Section 6.6, "Configuration Registers"	Added bit 5 BLK_PWR_CTRL to the Configuration 2 Register 44h. The TIMEOUT bit is set to '1' by default for functional revision B and is set to '0' by default for functional revision C.
	Section 6.28, "Revision Register"	Updated revision ID in register FFh from 81h to 82h.
Rev. 1.1 (11-17-10)	Document	Updated for functional revision B. See Section A.7, "Delta from Rev A (Mask A0) to Rev B (Mask B0)".
	Cover	Added to General Description: "includes circuitry and support for enhanced sensor proximity detection." Added the following Features: Calibrates for Parasitic Capacitance Analog Filtering for System Noise Sources Press and Hold feature for Volume-like Applications

CAP1106

Revision	Section/Figure/Entry	Correction
	Table 3-2, "Electrical Specifications"	Conditions for Power Supply Rejection modified adding the following: Sampling time = 2.56ms Averaging = 1 Negative Delta Counts = Disabled All other parameters default
	Section 6.11, "Calibration Activate Register"	Updated register description to indicate which re-calibration routine is used.
	Section 6.14, "Multiple Touch Configuration Register"	Updated register description to indicate what will happen.
	Table 6-34, "CSx_BN_TH Bit Decode"	Table heading changed from "Threshold Divide Setting" to "Percent Threshold Setting".
Rev. 1.0 (06-14-10)	Initial release	

THE MICROCHIP WEB SITE

Microchip provides online support via our WWW site at www.microchip.com. This web site is used as a means to make files and information easily available to customers. Accessible by using your favorite Internet browser, the web site contains the following information:

- **Product Support** – Data sheets and errata, application notes and sample programs, design resources, user's guides and hardware support documents, latest software releases and archived software
- **General Technical Support** – Frequently Asked Questions (FAQ), technical support requests, online discussion groups, Microchip consultant program member listing
- **Business of Microchip** – Product selector and ordering guides, latest Microchip press releases, listing of seminars and events, listings of Microchip sales offices, distributors and factory representatives

CUSTOMER CHANGE NOTIFICATION SERVICE

Microchip's customer notification service helps keep customers current on Microchip products. Subscribers will receive e-mail notification whenever there are changes, updates, revisions or errata related to a specified product family or development tool of interest.

To register, access the Microchip web site at www.microchip.com. Under "Support", click on "Customer Change Notification" and follow the registration instructions.

CUSTOMER SUPPORT

Users of Microchip products can receive assistance through several channels:

- Distributor or Representative
- Local Sales Office
- Field Application Engineer (FAE)
- Technical Support

Customers should contact their distributor, representative or field application engineer (FAE) for support. Local sales offices are also available to help customers. A listing of sales offices and locations is included in the back of this document.

Technical support is available through the web site at: <http://www.microchip.com/support>

PRODUCT IDENTIFICATION SYSTEM

To order or obtain information, e.g., on pricing or delivery, refer to the factory or the listed sales office.

PART NO.
Device **[X]** - **[X]** - **XXX** - **[X]⁽¹⁾**
 Temperature Addressing Package Tape and Reel
 Range Option

Device:	CAP1106
Temperature Range:	Blank = 0°C to +85°C (Extended Commercial)
Package:	AIA = DFN
Tape and Reel Option:	TR = Tape and Reel ⁽¹⁾

Example:

CAP1106-1-AIA-TR 10-pin DFN 3mm x 3mm (RoHS compliant) Six capacitive touch sensor inputs, SMBus interface Reel size is 4,000 pieces
--

Note 1: Tape and Reel identifier only appears in the catalog part number description. This identifier is used for ordering purposes and is not printed on the device package. Check with your Microchip Sales Office for package availability with the Tape and Reel option.

Note the following details of the code protection feature on Microchip devices:

- Microchip products meet the specification contained in their particular Microchip Data Sheet.
- Microchip believes that its family of products is one of the most secure families of its kind on the market today, when used in the intended manner and under normal conditions.
- There are dishonest and possibly illegal methods used to breach the code protection feature. All of these methods, to our knowledge, require using the Microchip products in a manner outside the operating specifications contained in Microchip's Data Sheets. Most likely, the person doing so is engaged in theft of intellectual property.
- Microchip is willing to work with the customer who is concerned about the integrity of their code.
- Neither Microchip nor any other semiconductor manufacturer can guarantee the security of their code. Code protection does not mean that we are guaranteeing the product as “unbreakable.”

Code protection is constantly evolving. We at Microchip are committed to continuously improving the code protection features of our products. Attempts to break Microchip's code protection feature may be a violation of the Digital Millennium Copyright Act. If such acts allow unauthorized access to your software or other copyrighted work, you may have a right to sue for relief under that Act.

Information contained in this publication regarding device applications and the like is provided only for your convenience and may be superseded by updates. It is your responsibility to ensure that your application meets with your specifications. MICROCHIP MAKES NO REPRESENTATIONS OR WARRANTIES OF ANY KIND WHETHER EXPRESS OR IMPLIED, WRITTEN OR ORAL, STATUTORY OR OTHERWISE, RELATED TO THE INFORMATION, INCLUDING BUT NOT LIMITED TO ITS CONDITION, QUALITY, PERFORMANCE, MERCHANTABILITY OR FITNESS FOR PURPOSE. Microchip disclaims all liability arising from this information and its use. Use of Microchip devices in life support and/or safety applications is entirely at the buyer's risk, and the buyer agrees to defend, indemnify and hold harmless Microchip from any and all damages, claims, suits, or expenses resulting from such use. No licenses are conveyed, implicitly or otherwise, under any Microchip intellectual property rights.

Trademarks

The Microchip name and logo, the Microchip logo, dsPIC, FlashFlex, KEELOQ, KEELOQ logo, MPLAB, PIC, PICmicro, PICSTART, PIC³² logo, rPIC, SST, SST Logo, SuperFlash and UNI/O are registered trademarks of Microchip Technology Incorporated in the U.S.A. and other countries.

FilterLab, Hampshire, HI-TECH C, Linear Active Thermistor, MTP, SEEVAL and The Embedded Control Solutions Company are registered trademarks of Microchip Technology Incorporated in the U.S.A.

Silicon Storage Technology is a registered trademark of Microchip Technology Inc. in other countries.

Analog-for-the-Digital Age, Application Maestro, BodyCom, chipKIT, chipKIT logo, CodeGuard, dsPICDEM, dsPICDEM.net, dsPICworks, dsSPEAK, ECAN, ECONOMONITOR, FanSense, HI-TIDE, In-Circuit Serial Programming, ICSP, Mindi, MiWi, MPASM, MPF, MPLAB Certified logo, MPLIB, MPLINK, mTouch, Omniscient Code Generation, PICC, PICC-18, PICDEM, PICDEM.net, PICKit, PICtail, REAL ICE, rFLAB, Select Mode, SQI, Serial Quad I/O, Total Endurance, TSHARC, UniWinDriver, WiperLock, ZENA and Z-Scale are trademarks of Microchip Technology Incorporated in the U.S.A. and other countries.

SQTP is a service mark of Microchip Technology Incorporated in the U.S.A.

GestIC and ULPP are registered trademarks of Microchip Technology Germany II GmbH & Co. KG, a subsidiary of Microchip Technology Inc., in other countries.

A more complete list of registered trademarks and common law trademarks owned by Standard Microsystems Corporation (“SMSC”) is available at: www.smsc.com. The absence of a trademark (name, logo, etc.) from the list does not constitute a waiver of any intellectual property rights that SMSC has established in any of its trademarks.

All other trademarks mentioned herein are property of their respective companies.

© 2014, Microchip Technology Incorporated, Printed in the U.S.A., All Rights Reserved.

ISBN: 9781620777206

QUALITY MANAGEMENT SYSTEM
CERTIFIED BY DNV
== ISO/TS 16949 ==

Microchip received ISO/TS-16949:2009 certification for its worldwide headquarters, design and wafer fabrication facilities in Chandler and Tempe, Arizona; Gresham, Oregon and design centers in California and India. The Company's quality system processes and procedures are for its PIC[®] MCUs and dsPIC[®] DSCs, KEELOQ[®] code hopping devices, Serial EEPROMs, microperipherals, nonvolatile memory and analog products. In addition, Microchip's quality system for the design and manufacture of development systems is ISO 9001:2000 certified.



Worldwide Sales and Service

AMERICAS

Corporate Office
2355 West Chandler Blvd.
Chandler, AZ 85224-6199
Tel: 480-792-7200
Fax: 480-792-7277
Technical Support:
<http://www.microchip.com/support>
Web Address:
www.microchip.com

Atlanta
Duluth, GA
Tel: 678-957-9614
Fax: 678-957-1455

Austin, TX
Tel: 512-257-3370

Boston
Westborough, MA
Tel: 774-760-0087
Fax: 774-760-0088

Chicago
Itasca, IL
Tel: 630-285-0071
Fax: 630-285-0075

Cleveland
Independence, OH
Tel: 216-447-0464
Fax: 216-447-0643

Dallas
Addison, TX
Tel: 972-818-7423
Fax: 972-818-2924

Detroit
Novi, MI
Tel: 248-848-4000

Houston, TX
Tel: 281-894-5983

Indianapolis
Noblesville, IN
Tel: 317-773-8323
Fax: 317-773-5453

Los Angeles
Mission Viejo, CA
Tel: 949-462-9523
Fax: 949-462-9608

New York, NY
Tel: 631-435-6000

San Jose, CA
Tel: 408-735-9110

Canada - Toronto
Tel: 905-673-0699
Fax: 905-673-6509

ASIA/PACIFIC

Asia Pacific Office
Suites 3707-14, 37th Floor
Tower 6, The Gateway
Harbour City, Kowloon
Hong Kong
Tel: 852-2401-1200
Fax: 852-2401-3431

Australia - Sydney
Tel: 61-2-9868-6733
Fax: 61-2-9868-6755

China - Beijing
Tel: 86-10-8569-7000
Fax: 86-10-8528-2104

China - Chengdu
Tel: 86-28-8665-5511
Fax: 86-28-8665-7889

China - Chongqing
Tel: 86-23-8980-9588
Fax: 86-23-8980-9500

China - Hangzhou
Tel: 86-571-2819-3187
Fax: 86-571-2819-3189

China - Hong Kong SAR
Tel: 852-2943-5100
Fax: 852-2401-3431

China - Nanjing
Tel: 86-25-8473-2460
Fax: 86-25-8473-2470

China - Qingdao
Tel: 86-532-8502-7355
Fax: 86-532-8502-7205

China - Shanghai
Tel: 86-21-5407-5533
Fax: 86-21-5407-5066

China - Shenyang
Tel: 86-24-2334-2829
Fax: 86-24-2334-2393

China - Shenzhen
Tel: 86-755-8864-2200
Fax: 86-755-8203-1760

China - Wuhan
Tel: 86-27-5980-5300
Fax: 86-27-5980-5118

China - Xian
Tel: 86-29-8833-7252
Fax: 86-29-8833-7256

China - Xiamen
Tel: 86-592-2388138
Fax: 86-592-2388130

China - Zhuhai
Tel: 86-756-3210040
Fax: 86-756-3210049

ASIA/PACIFIC

India - Bangalore
Tel: 91-80-3090-4444
Fax: 91-80-3090-4123

India - New Delhi
Tel: 91-11-4160-8631
Fax: 91-11-4160-8632

India - Pune
Tel: 91-20-3019-1500

Japan - Osaka
Tel: 81-6-6152-7160
Fax: 81-6-6152-9310

Japan - Tokyo
Tel: 81-3-6880-3770
Fax: 81-3-6880-3771

Korea - Daegu
Tel: 82-53-744-4301
Fax: 82-53-744-4302

Korea - Seoul
Tel: 82-2-554-7200
Fax: 82-2-558-5932 or
82-2-558-5934

Malaysia - Kuala Lumpur
Tel: 60-3-6201-9857
Fax: 60-3-6201-9859

Malaysia - Penang
Tel: 60-4-227-8870
Fax: 60-4-227-4068

Philippines - Manila
Tel: 63-2-634-9065
Fax: 63-2-634-9069

Singapore
Tel: 65-6334-8870
Fax: 65-6334-8850

Taiwan - Hsin Chu
Tel: 886-3-5778-366
Fax: 886-3-5770-955

Taiwan - Kaohsiung
Tel: 886-7-213-7830

Taiwan - Taipei
Tel: 886-2-2508-8600
Fax: 886-2-2508-0102

Thailand - Bangkok
Tel: 66-2-694-1351
Fax: 66-2-694-1350

EUROPE

Austria - Wels
Tel: 43-7242-2244-39
Fax: 43-7242-2244-393

Denmark - Copenhagen
Tel: 45-4450-2828
Fax: 45-4485-2829

France - Paris
Tel: 33-1-69-53-63-20
Fax: 33-1-69-30-90-79

Germany - Dusseldorf
Tel: 49-2129-3766400

Germany - Munich
Tel: 49-89-627-144-0
Fax: 49-89-627-144-44

Germany - Pforzheim
Tel: 49-7231-424750

Italy - Milan
Tel: 39-0331-742611
Fax: 39-0331-466781

Italy - Venice
Tel: 39-049-7625286

Netherlands - Drunen
Tel: 31-416-690399
Fax: 31-416-690340

Poland - Warsaw
Tel: 48-22-3325737

Spain - Madrid
Tel: 34-91-708-08-90
Fax: 34-91-708-08-91

Sweden - Stockholm
Tel: 46-8-5090-4654

UK - Wokingham
Tel: 44-118-921-5800
Fax: 44-118-921-5820

10/28/13