

PFT 25 TF

Housing material

Pressed steel

Dimensions

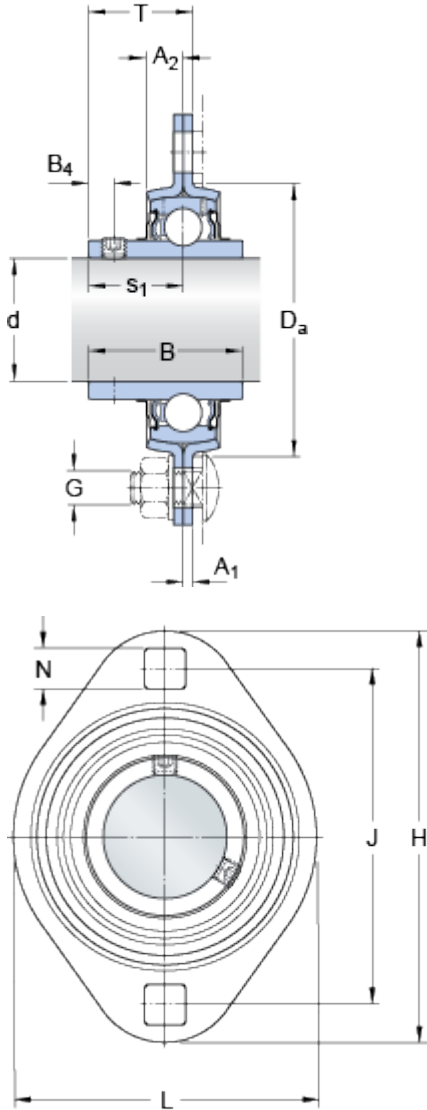

d		25	mm
A ₁		2	mm
A ₂		9	mm
B		34.1	mm
B ₄		5	mm
D _a	min.	56	mm
J		76.2	mm
H		95	mm
L		71	mm
N		8.7	mm
s ₁		19.8	mm
T		21.8	mm

Dowel pins

Grease fitting

Threaded hole

Calculation data

Basic dynamic load rating	C	14	kN
Basic static load rating	C ₀	7.8	kN
Fatigue load limit	P _u	0.335	kN
Limiting speed		7000	r/min

(with shaft tolerance h6)

Mass

Mass bearing unit	0.28	kg
-------------------	------	----

Mounting information

Thread grub screw	G 2	M6x0.75	
Hexagonal key size for grub screw	N	3	mm
Recommended tightening torque for grub screw		4	N·m
Recommended diameter for attachment bolts, mm	G	8	mm
Recommended diameter for attachment bolts, inch	G	0.313	in

Appertaining products

Housing	PFT 52
Bearing	YAR 205-2F