

Regulations  
No.

195A803E

**Tentative**

Total Pages

14

Page

1

**The product specifications described in this book are subject to change without notice for the product which is currently under development. At the final stage of your design, purchasing, or use of the product, therefore, ask for the most up-to-date Product Standards in advance to make sure that the latest specifications satisfy your requirements.**

# User's Guide for Evaluation Board

Part No.

EVB-NN30195A

Industrial Devices Company  
Panasonic Corporation

2012-05-24

Revised

Regulations No.	195A803E	<b>User's Guide for Evaluation Board</b> <b>Tentative</b>	EVB-NN30195A	
			Total Pages	Page
			14	2

## Contents

### 1 Introduction

1.1 Overview .....	3
1.2 Features .....	3
1.3 Typical Applications .....	3
1.4 Package .....	3
1.5 Type .....	3
1.6 Block Diagram .....	4

### 2 Evaluation Board

2.1 Appearance .....	5
2.2 Jumper setup .....	6

3 Schematic .....	7
-------------------	---

### 4 Test Setup

4.1 Main Test Points and Jumpers .....	8
4.2 Output Voltage Setpoint .....	9

5 Bill of Materials .....	10
---------------------------	----

6 Board Layout .....	11
----------------------	----

Usage Notes .....	14
-------------------	----

	2012-05-24	
	Revised	

Regulations No.	195A803E	<b>User's Guide</b> <b>for Evaluation Board</b> <b>Tentative</b>	EVB-NN30195A	
			Total Pages	Page
			14	3

## 1 Introduction

This user's guide contains background information for the

### NN30195A : 6A Synchronous DCDC Step Down Regulator with Integrated Power MOSFET

as well as support documentation for the NN30195A Evaluation Board (EVB-NN30195A). Also included are the schematic, the test set-up, the bill of materials and the Board Layout for the Evaluation Board.

### 1.1 Overview

NN30195A is a synchronous DCDC Step Down Regulator (1-ch) with integrated power MOSFETs, which employs hysteretic control system. By this system, when load current changes suddenly, it responds at high speed and minimizes the changes of output voltage. Since it is possible to use capacitors with small capacitance and it is unnecessary to add external parts for system phase compensation, this IC realizes downsizing of set and reducing in the number of external parts. Output voltage is adjustable by user. Maximum current is 6 A.

### 1.2 Features

- High-speed response DCDC Step Down Regulator circuit that employs the hysteretic control system
- Integrated Two 25mΩ (Typ) MOSFETs for high efficiency
- Switchable FCCM (continuous) / SKIP (discontinuous) mode
- Input Voltage Range: AVIN: 4.5V~ 5.6V , PVIN: 2.9V(TBD) ~ 5.6V
- Output Voltage Range: 0.6V(TBD) ~ 3.5V
- Built-in 0.6V ± 1% (TBD) Reference Voltage
- Selectable Switching Frequency 500kHz/1MHz/2MHz
- Adjustable Soft Start
- Low Operating and Standby Quiescent Current
- Indication for normal Output Voltage to PGOOD pin
- Built-in Under Voltage Lockout (UVLO), Thermal Shut Down (TSD), Output Over-Voltage Detection (OVD), Output Over-Current Protection (OCP), Short-Circuit Protection (SCP) functions

Input voltage and output current range for the evaluation Board are given in Table 1.

Table 1. Input Voltage and Output Current Summary

Evaluation Board	Input Voltage range	Output Current Range
EVB-NN30195A	PVIN = 2.9V(TBD) to 5.6V AVIN = 4.5V to 5.6V *1	0A to 6A

\*1 : PVIN pin and AVIN pin are normally connected on Evaluation Board by 0 ohm resistor (R-AVIN).

### 1.3 Typical Applications

—High Current Distributed Power Systems such as HDDs (Hard Disk Drives), SSDs (Solid State Drives), PCs, Game consoles, Servers, Security Cameras, Network TVs, Home Appliances, OA Equipment etc.

### 1.4 Package

— 24pin Plastic Quad Flat Non-leaded Package Heat Slug Down (QFN Type)  
(Size : 4 × 4 mm, 0.5 mm pitch)

### 1.5 Type

—Multichip IC

Note: The parameters above is subject to change without notice for improvement.

	2012-05-24	
	Revised	



Regulations No.	195A803E	User's Guide for Evaluation Board <b>Tentative</b>		EVB-NN30195A	
				Total Pages	Page
				14	5

2 Evaluation Board

2.1 Appearance

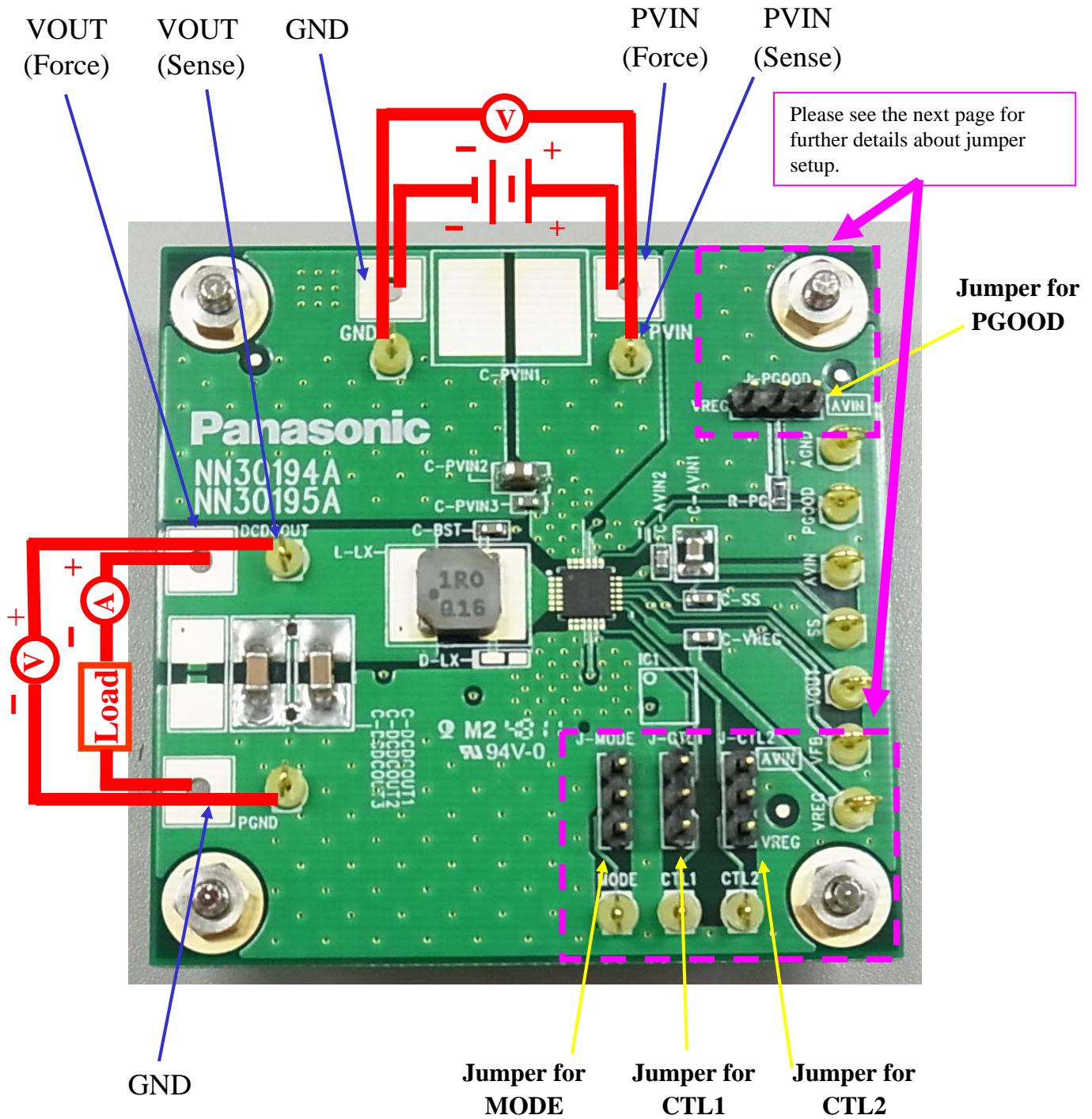

Figure 2. Appearance of Evaluation Board

Note: The parameters above is subject to change without notice for improvement.

	2012-05-24	
	Revised	

Regulations No.	195A803E	<b>User's Guide</b> <b>for Evaluation Board</b> <b>Tentative</b>	EVB-NN30195A	
			Total Pages	Page
			14	6

## 2.2 Jumper Setup

MODE pin, CTL1 pin, CTL2 pin, PGOOD pin are able to be controlled by J-MODE, J-CTL1, J-CTL2, J-PGOOD.

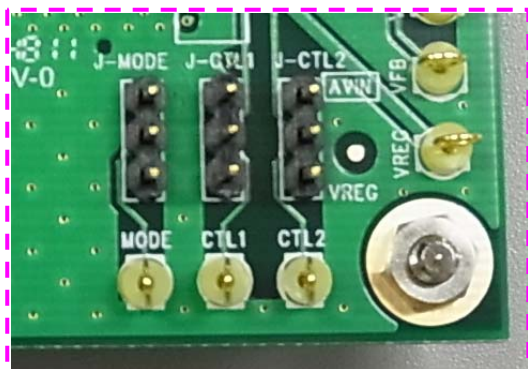

Figure 3. Appearance of J-MODE, J-CTL1, J-CTL2

Table 2. J-MODE (Control modes)

Jumper			
Mode	FCCM	SKIP	FCCM

Table 3. J-CTL1, J-CTL2 (Control SW frequency )

Jumper				
SW frequency	2MHz	1MHz	500kHz	OFF



Figure 4. Appearance of J-PGOOD

Table 4. J-PGOOD (Control the Voltage PGOOD pin pulled up to)

Jumper			
Pull up to	VREG	open	AVIN

Note: The parameters above is subject to change without notice for improvement.

	2012-05-24	
	Revised	

Regulations No.	195A803E	User's Guide for Evaluation Board <b>Tentative</b>		EVB-NN30195A	
				Total Pages	Page
				14	7

### 3 Schematic

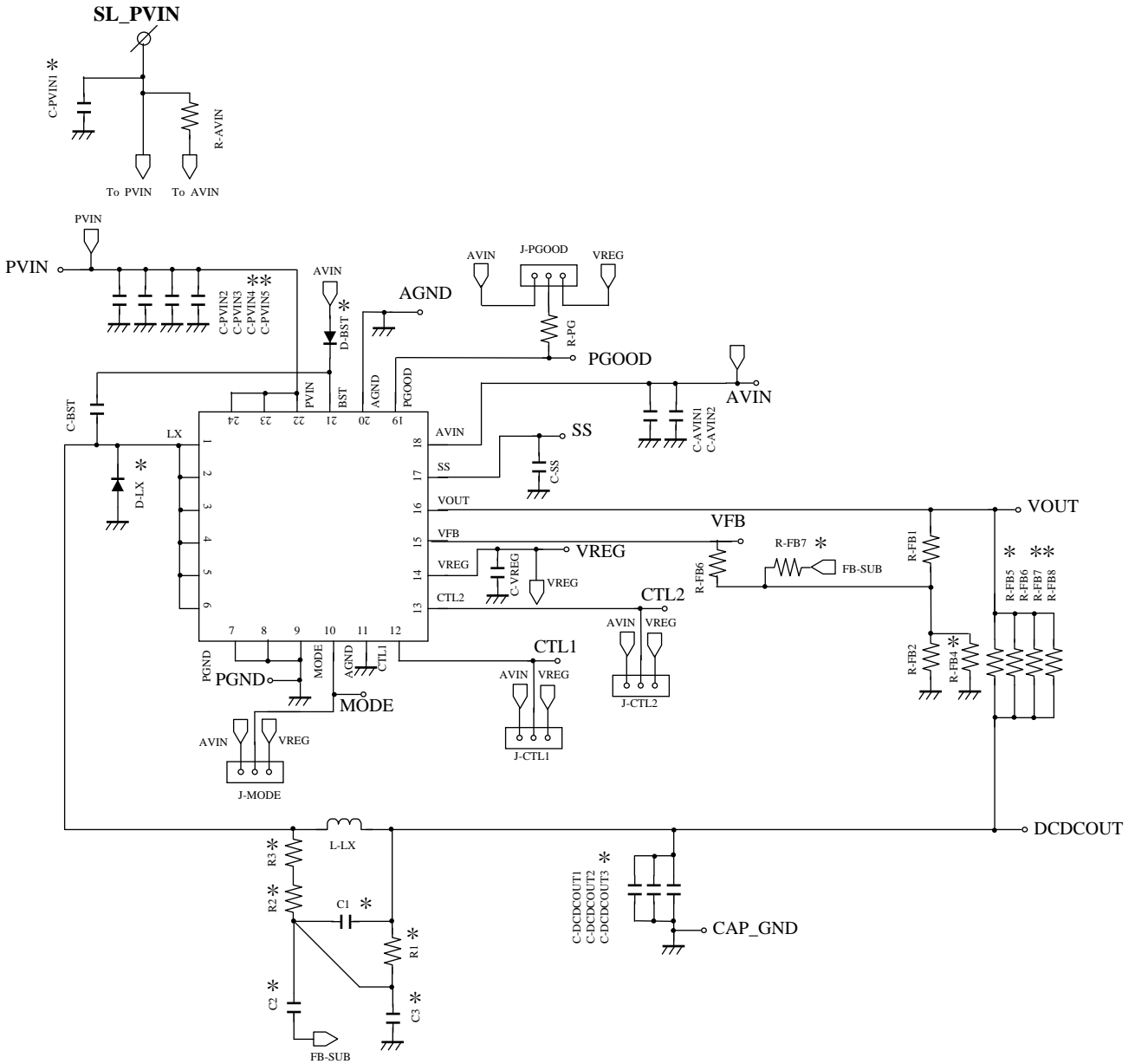

\*: Not Installed

Figure 5. Evaluation Board Schematic

Note: The parameters above is subject to change without notice for improvement.

	2012-05-24	
	Revised	

Regulations No.	195A803E	<b>User's Guide</b> <b>for Evaluation Board</b> <b>Tentative</b>	EVB-NN30195A	
			Total Pages	Page
			14	8

## 4 Test Setup

This section describes how to properly connect, set up and use the Evaluation Board.

### 4.1 Main Test Points and Jumpers

The Evaluation Board is provided with test points and jumpers as shown in Table 5.

A power supply cable of supplying 4A must be connected to the pad PVIN. The load must be connected to the pad DCDCOUT. Wire lengths must be minimized to reduce losses in the wires.

Test point PVIN provides a place to monitor the input voltages with GND providing a convenient ground reference.

Test point DCDCOUT is used to monitor the output voltage with GND as the ground reference.

Jumper Setup is shown in Table 6.

Table 5. Function of Main Test points and Jumpers

	Reference Designator	Default	Function
Main Test Points	PVIN	-	PVIN test point at PVIN connector
	DCDCOUT	-	DCDCOUT test point at DCDCOUT connector
Jumpers	J-MODE	-	3-pin headers to choose mode. Connect MODE to AVIN or VREG to choose FCCM mode, open to choose SKIP mode.
	J-CTL1, J-CTL2	-	3-pin headers to choose frequency. 500kHz / 1MHz / 2MHz / or DCDC off.
	J-PGOOD	open	3-pin headers for pull-up of PGOOD. Connect to VREG to allow pull up to VREG pin, to AVIN to allow pull up to AVIN pin.

Table 6. Jumper Setup

Jumper	Setup	Mode	Setup	Mode	Setup	Mode
J-MODE	J-MODE <input checked="" type="radio"/> AVIN <input type="radio"/> MODE pin <input type="radio"/> VREG	FCCM mode	J-MODE <input type="radio"/> AVIN <input type="radio"/> MODE pin <input type="radio"/> VREG	SKIP mode	J-MODE <input type="radio"/> AVIN <input checked="" type="radio"/> MODE pin <input type="radio"/> VREG	FCCM mode
J-CTL1, J-CTL2	J-CTL1 J-CTL2 <input checked="" type="radio"/> AVIN <input checked="" type="radio"/> CTL1, 2 pin <input type="radio"/> VREG	2MHz	J-CTL1 J-CTL2 <input checked="" type="radio"/> AVIN <input type="radio"/> CTL1, 2 pin <input type="radio"/> VREG	1MHz		
	J-CTL1 J-CTL2 <input type="radio"/> AVIN <input checked="" type="radio"/> CTL1, 2 pin <input type="radio"/> VREG	500kHz	J-CTL1 J-CTL2 <input type="radio"/> AVIN <input type="radio"/> CTL1, 2 pin <input type="radio"/> VREG	DCDC off		
J-PGOOD	J-PGOOD <input checked="" type="radio"/> Pull up to AVIN <input type="radio"/> PGOOD pin <input type="radio"/> Pull up to VREG	Pull up to AVIN	J-PGOOD <input type="radio"/> Pull up to AVIN <input type="radio"/> PGOOD pin <input checked="" type="radio"/> Pull up to VREG	open	J-PGOOD <input type="radio"/> Pull up to AVIN <input checked="" type="radio"/> PGOOD pin <input type="radio"/> Pull up to VREG	Pull up to VREG

Note: The parameters above is subject to change without notice for improvement.

	2012-05-24	
	Revised	

Regulations No.	195A803E	<b>User's Guide</b> <b>for Evaluation Board</b> <b>Tentative</b>	EVB-NN30195A	
			Total Pages	Page
			14	9

## 4.2 Output Voltage Setpoint

To change the output voltage of the Evaluation Board, it is necessary to change the value of resistor R-FB1, R-FB2. The values of R-FB1, R-FB2 for a specific output value can be calculated using Equation (1).

For output voltage from 0.6V to 3.5V:

$$V_{out} = \left( \frac{R-FB1 + R-FB2}{R-FB2} \right) \times 0.6 \quad \text{----- (1)}$$

Table 7 lists the R-FB1, R-FB2 values for some common output voltage.

Table 7. Output Voltages

Output Voltage (V)	R-FB1(k ohm)	R-FB2(k ohm)
1.00	1.0	1.5
1.05	1.2	1.6
1.20	1.0	1.0
1.50	1.5	1.0
1.80	2.0	1.0

Note: The parameters above is subject to change without notice for improvement.

	2012-05-24	
	Revised	

Regulations No.	195A803E	<b>User's Guide</b> <b>for Evaluation Board</b> <b>Tentative</b>	EVB-NN30195A	
			Total Pages	Page
			14	10

## 5 Bill of Materials

Table 8 presents the bill of materials for the Evaluation Board.

Table 8. Evaluation Board Bill of Materials

Reference Designator	QTY	Value	Description	Size *4	Manufacturer	Part Number
C1, C2,C3	-	-	-	-	-	-
C-AVIN1	1	10uF	Capacitor, Ceramic, 10V, X7R, 10%	0805	Murata	GRM21BR71A106KE51L
C-AVIN2	1	0.1uF	Capacitor, Ceramic, 100V, X7R, 10%	0603	Murata	GRM188R72A104KA35L
C-BST	1	0.1uF	Capacitor, Ceramic, 100V, X7R, 10%	0603	Murata	GRM188R72A104KA35L
C-DCDCOUT	2	22uF	Capacitor, Ceramic, 10V, X7R, 10%	1210	Murata	GRM31CR71E226KE15L
C-PVIN1, C-PVIN4, C-PVIN5	-	-	-	-	-	-
C-PVIN2	1	22uF	Capacitor, Ceramic, 10V, X7R, 10%	1206	Murata	GRM31CR71A226KE15L
C-PVIN3	1	0.1uF	Capacitor, Ceramic, 100V, X7R, 10%	0603	Murata	GRM188R72A104KA35L
C-SS	1	10nF	Capacitor, Ceramic, 100V, X7R, 10%	0603	Murata	GRM188R72A103KA01L
C-VREG	1	1.0uF	Capacitor, Ceramic, 25V, X7R, 10%	0603	Murata	GRM188R71E105KA12L
D-BST	-	-	-	-	-	-
D-LX	-	-	-	-	-	-
J-EN, J-FSEL, J-MODE, J-PGOOD	-	-	-	-	-	-
L-LX	1	1.0uH	Inductor, 8.1A, 6.9mΩ	0.276 × 0.260 inch	Panasonic	ETQP3W1R0WFN
R1,R2,R3	-	-	-	-	-	-
R-AVIN	1	0	Resistor, Chip, 0.1W	0603	Panasonic	ERJ3GEY0R00V
R-FB1 *2	1	1.0k	Resistor, Chip, 0.1W, 1%	0603	Panasonic	ERJ3EKF1001V
R-FB2 *2	1	1.5k	Resistor, Chip, 0.1W, 1%	0603	Panasonic	ERJ3EKF1501V
R-FB3	1	0	Resistor, Chip, 0.1W	0603	Panasonic	ERJ3GEY0R00V
R-FB6	1	0	Resistor, Chip, 0.1W	0603	Panasonic	ERJ3GEY0R00V
R-FB4	-	-	-	-	-	-
R-FB6 *3	1	0	Resistor, Chip, 0.1W	0603	Panasonic	ERJ3GEY0R00V
R-FB5, R-FB7, R-FB8 *3	-	-	-	-	-	-
R-PG	1	100k	Resistor, Chip, 0.1W, 1%	0603	Panasonic	ERJ3EKF1003V

\*2 : These resistors determine output voltage.

The setting in the above table sets the output voltage for 1.0V.

To change the output voltage, it is necessary to change these resistors following Equation (1) in the section 4.2.

\*3 : These pads are for changing feedback route.

Only R-FB6 is normally installed.

\*4 : These values comply with EIA standards.

Note: The parameters above is subject to change without notice for improvement.

	2012-05-24	
	Revised	

Regulations No.	195A803E	User's Guide for Evaluation Board <b>Tentative</b>		EVB-NN30195A	
				Total Pages	Page
				14	11

## 6 Board Layout

The board layout for the evaluation board is shown in Figure 6 through Figure 11.

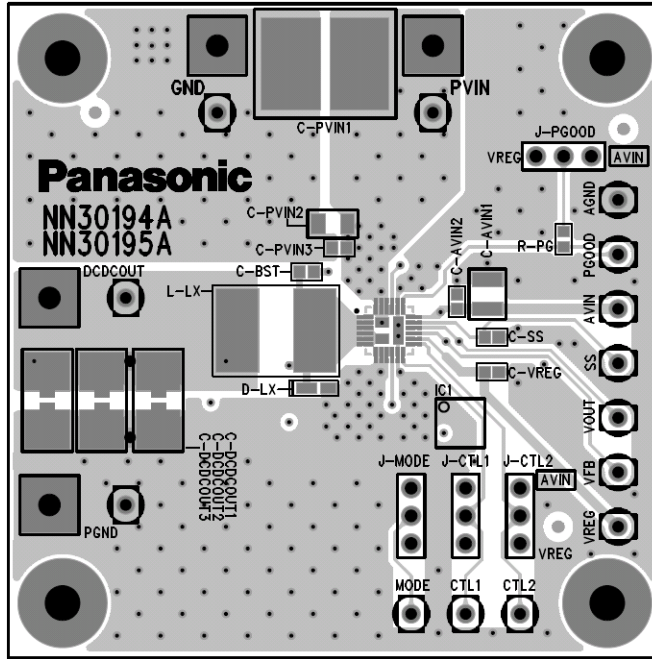

Figure 6. Top Layer with silk screen ( Top View )

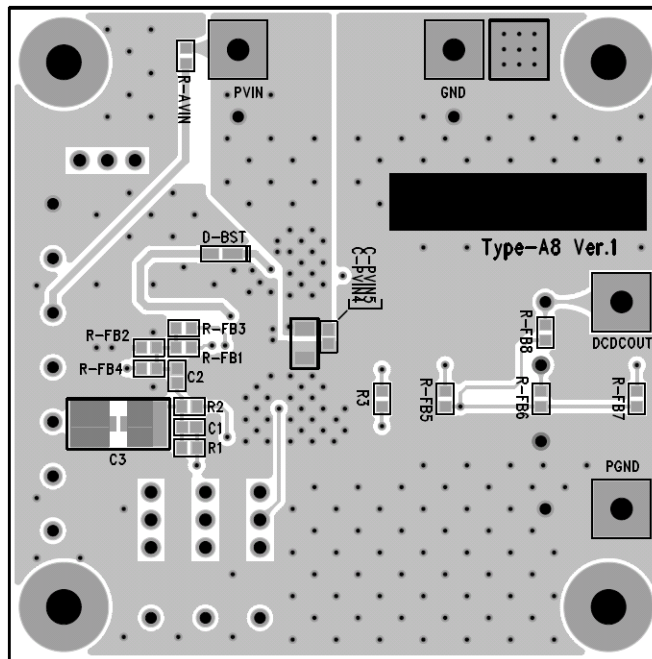

Figure 7. Bottom Layer with silk screen ( Bottom View )

Note: The parameters above is subject to change without notice for improvement.

	2012-05-24	
	Revised	

Regulations No.	195A803E	User's Guide for Evaluation Board <b>Tentative</b>	EVB-NN30195A	
			Total Pages	Page
			14	12

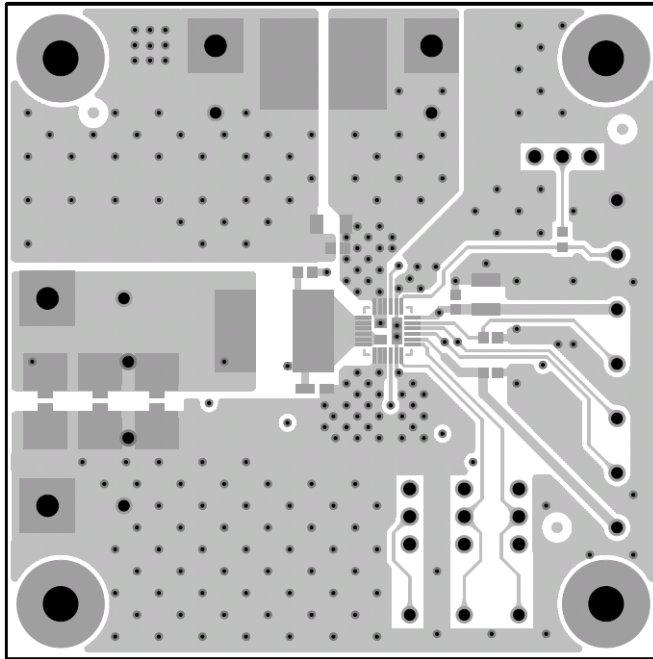

Figure 8. Top Layer ( Top View )

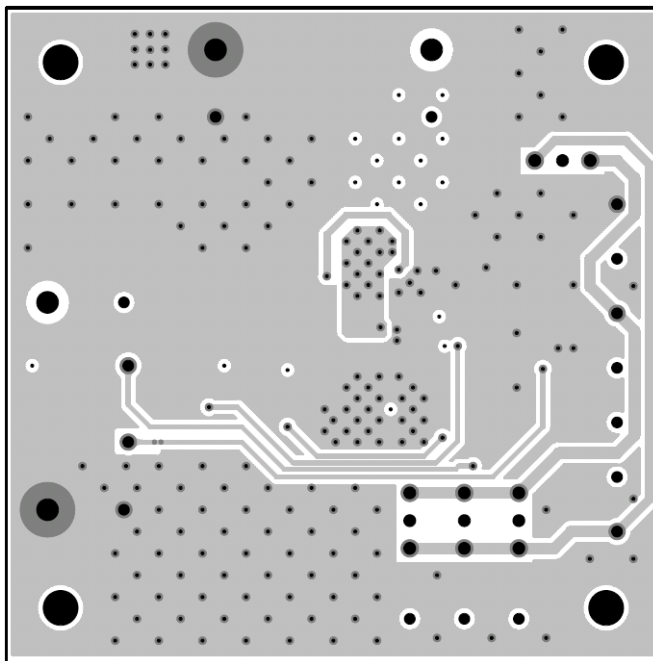

Figure 9. Layer 2 ( Top View )

Note: The parameters above is subject to change without notice for improvement.

	2012-05-24	
	Revised	

Regulations No.	195A803E	User's Guide for Evaluation Board <b>Tentative</b>	EVB-NN30195A	
			Total Pages	Page
			14	13

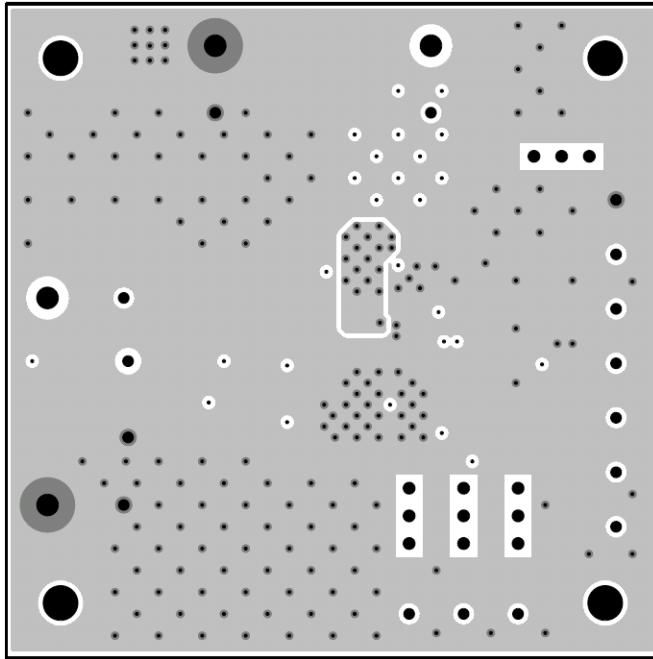

Figure 10. Layer 3 ( Top View )

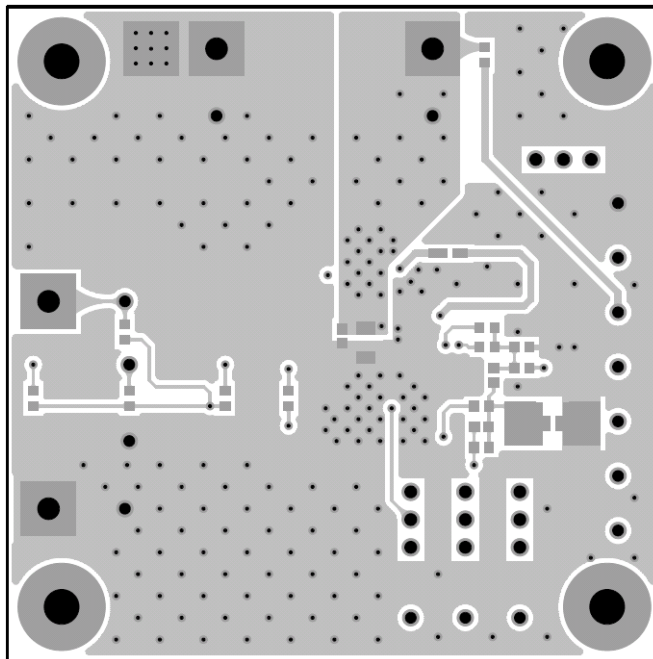

Figure 11. Bottom Layer ( Top View )

Note: The parameters above is subject to change without notice for improvement.

	2012-05-24	
	Revised	

Regulations No.	195A803E	<b>User's Guide</b> <b>for Evaluation Board</b> <b>Tentative</b>	EVB-NN30195A	
			Total Pages	Page
			14	14

## ■ Usage Notes

— Special attention and precaution in using

1. This DCDC Step Down Regulator is intended to be used for general electronic equipment.

Consult our sales staff in advance for information on the following applications:

- Special applications in which exceptional quality and reliability are required, or if the failure or malfunction of this IC may directly jeopardize life or harm the human body.
- Any applications other than the standard applications intended.
  - (1) Space appliance (such as artificial satellite, and rocket)
  - (2) Traffic control equipment (such as for automobile, airplane, train, and ship)
  - (3) Medical equipment for life support
  - (4) Submarine transponder
  - (5) Control equipment for power plant
  - (6) Disaster prevention and security device
  - (7) Weapon
  - (8) Others : Applications of which reliability equivalent to (1) to (7) is required

It is to be understood that our company shall not be held responsible for any damage incurred as a result of or in connection with your using the IC described in this book for any special application, unless our company agrees to your using the IC in this book for any special application.

2. Pay attention to the direction of LSI. When mounting it in the wrong direction onto the PCB (printed-circuit-board), it might smoke or ignite.
3. Pay attention in the PCB (printed-circuit-board) pattern layout in order to prevent damage due to short circuit between pins. In addition, refer to the Pin Description for the pin configuration.
4. Perform a visual inspection on the PCB before applying power, otherwise damage might happen due to problems such as a solder-bridge between the pins of the semiconductor device. Also, perform a full technical verification on the assembly quality, because the same damage possibly can happen due to conductive substances, such as solder ball, that adhere to the LSI during transportation.
5. Take notice in the use of this product that it might break or occasionally smoke when an abnormal state occurs such as output pin- $V_{CC}$  short (Power supply fault), output pin-GND short (Ground fault), or output-to-output-pin short (load short) . And, safety measures such as an installation of fuses are recommended because the extent of the above-mentioned damage and smoke emission will depend on the current capability of the power supply.
6. When designing your equipment, comply with the range of absolute maximum rating and the guaranteed operating conditions (operating power supply voltage and operating environment etc.). Especially, please be careful not to exceed the range of absolute maximum rating on the transient state, such as power-on, power-off and mode-switching. Otherwise, we will not be liable for any defect which may arise later in your equipment.  
Even when the products are used within the guaranteed values, take into the consideration of incidence of break down and failure mode, possible to occur to semiconductor products. Measures on the systems such as redundant design, arresting the spread of fire or preventing glitch are recommended in order to prevent physical injury, fire, social damages, for example, by using the products.
7. When using the LSI for new models, verify the safety including the long-term reliability for each product.
8. When the application system is designed by using this LSI, be sure to confirm notes in this book.  
Be sure to read the notes to descriptions and the usage notes in the book.

	2012-05-24	
	Revised	

## Request for your special attention and precautions in using the technical information and semiconductors described in this book

- (1) If any of the products or technical information described in this book is to be exported or provided to non-residents, the laws and regulations of the exporting country, especially, those with regard to security export control, must be observed.
- (2) The technical information described in this book is intended only to show the main characteristics and application circuit examples of the products. No license is granted in and to any intellectual property right or other right owned by Panasonic Corporation or any other company. Therefore, no responsibility is assumed by our company as to the infringement upon any such right owned by any other company which may arise as a result of the use of technical information described in this book.
- (3) The products described in this book are intended to be used for general applications (such as office equipment, communications equipment, measuring instruments and household appliances), or for specific applications as expressly stated in this book. Consult our sales staff in advance for information on the following applications:
  - Special applications (such as for airplanes, aerospace, automotive equipment, traffic signaling equipment, combustion equipment, life support systems and safety devices) in which exceptional quality and reliability are required, or if the failure or malfunction of the products may directly jeopardize life or harm the human body.It is to be understood that our company shall not be held responsible for any damage incurred as a result of or in connection with your using the products described in this book for any special application, unless our company agrees to your using the products in this book for any special application.
- (4) The products and product specifications described in this book are subject to change without notice for modification and/or improvement. At the final stage of your design, purchasing, or use of the products, therefore, ask for the most up-to-date Product Standards in advance to make sure that the latest specifications satisfy your requirements.
- (5) When designing your equipment, comply with the range of absolute maximum rating and the guaranteed operating conditions (operating power supply voltage and operating environment etc.). Especially, please be careful not to exceed the range of absolute maximum rating on the transient state, such as power-on, power-off and mode-switching. Otherwise, we will not be liable for any defect which may arise later in your equipment.

Even when the products are used within the guaranteed values, take into the consideration of incidence of break down and failure mode, possible to occur to semiconductor products. Measures on the systems such as redundant design, arresting the spread of fire or preventing glitch are recommended in order to prevent physical injury, fire, social damages, for example, by using the products.
- (6) Comply with the instructions for use in order to prevent breakdown and characteristics change due to external factors (ESD, EOS, thermal stress and mechanical stress) at the time of handling, mounting or at customer's process. When using products for which damp-proof packing is required, satisfy the conditions, such as shelf life and the elapsed time since first opening the packages.
- (7) This book may be not reprinted or reproduced whether wholly or partially, without the prior written permission of our company.