

Absolute encoders - modular bus covers

Shaft with clamping or synchro flange

Optical single and multiturn encoders 13 bit ST / 16 bit MT

GXAMW, GXMMW - *multivo*



GXMMW with modular bus cover

Features

- Encoder single- or multiturn / bus cover
- Optical sensing
- Resolution: singleturn 13 bit, multiturn 16 bit
- Clamping or synchro flange
- CANopen/DeviceNet/EtherCAT/EtherNet-IP/SAEJ1939 fibre-optic/PROFINET/Power over EtherCAT POWERLINK/Profibus/SSI
- Code continuity check optional by bus

Optional

- Incremental outputs and stainless steel design

Technical data - electrical ratings

Voltage supply	10...30 VDC
Reverse polarity protection	Yes
Consumption w/o load	≤100 mA (24 VDC)
Initializing time (typ.)	250 ms after power on
Interfaces	CANopen, DeviceNet, Fibre optic, EtherCAT, EtherNet/IP, PoE, Profibus, PROFINET, POWERLINK, SAEJ1939, SSI
User address	Rotary switch in bus cover (type-specific)
Steps per turn	≤8192 / 13 bit
Incremental output	2048 pulses A90°B (optional)
Absolute accuracy	±0.025 °
Sensing method	Optical
Code	Binary
Code sequence	CW/CCW programmable
Interference immunity	DIN EN 61000-6-2
Emitted interference	DIN EN 61000-6-4
Programmable parameters	Steps per revolution Number of revolutions Preset Scaling Rotational direction
Diagnostic functions	Position or parameter error Multiturn sensing
Status indicator	DUO-LED integrated in bus cover
Approval	UL approval / E63076
GXAMW	
Function	Singleturn
GXMMW	
Function	Multiturn
Number of turns	≤65536 / 16 bit

Technical data - mechanical design

Dimensions (flange)	ø58 mm
Shaft	ø10 mm (clamping flange) ø6 mm (synchro flange)
Flange	Clamping or synchro flange
Protection DIN EN 60529	IP 54 (without shaft seal), IP 65 (with shaft seal)
Operating speed	≤10000 rpm (mechanical) ≤6000 rpm (electric)
Starting torque	≤0.015 Nm IP 54 ≤0.03 Nm IP 65
Rotor moment of inertia	20 gcm ²
Admitted shaft load	≤20 N axial ≤40 N radial
Materials	Housing: steel Flange: aluminium Bus cover: zinc die-cast or aluminium
Operating temperature	-25...+85 °C -40...+85 °C (optional)
Relative humidity	95 % non-condensing
Resistance	DIN EN 60068-2-6 Vibration 10 g, 16-2000 Hz DIN EN 60068-2-27 Shock 200 g, 6 ms
Weight approx.	650 g
Connection	Bus cover

Absolute encoders - modular bus covers

Shaft with clamping or synchro flange

Optical single and multiturn encoders 13 bit ST / 16 bit MT

GXAMW, GXMMW - multivo

Part number

Singleturn

GXAMW. 20

	Interface
3P32	Profibus-DPV0 / cable gland
3PA2	Profibus-DPV0 / connector M12
3V32	Profibus-DPV2 / cable gland
3VA2	Profibus-DPV2 / connector M12
3EA2	PROFINET / connector M12
EPA6	EtherCAT / connector M12
8EA2	EtherNet/IP / connector M12
EEA2	Power over EtherCAT / connector M12
5EA2	POWERLINK / connector M12
5P32	CANopen / cable gland
5PA2	CANopen / connector M12
8P22	DeviceNet / cable gland
8PA2	DeviceNet / connector M12
LM32	Fibre-optic / cable gland
2PA2	SSI / connector M12
5B32	SAEJ1939 / cable gland
5BA2	SAEJ1939 / connector M12

Flange / Shaft

- 0 Clamping flange / ø10 mm IP 54
- A Clamping flange / ø10 mm IP 65
- 1 Synchro flange / ø6 mm IP 54
- B Synchro flange / ø6 mm IP 65

CD with file descriptions is not included in the delivery. You may order them on CD as accessory free-of-charge under part number Z 150.022.

Multiturn

GXMMW. 20

	Interface
3P32	Profibus-DPV0 / cable gland
3PA2	Profibus-DPV0 / connector M12
3V32	Profibus-DPV2 / cable gland
3VA2	Profibus-DPV2 / connector M12
3EA2	PROFINET / connector M12
EPA6	EtherCAT / connector M12
8EA2	EtherNet/IP / connector M12
EEA2	Power over EtherCAT / connector M12
5EA2	POWERLINK / connector M12
5P32	CANopen / cable gland
5PA2	CANopen / connector M12
8P22	DeviceNet / cable gland
8PA2	DeviceNet / connector M12
LM32	Fibre-optic / cable gland
2PA2	SSI / connector M12
5B32	SAEJ1939 / cable gland
5BA2	SAEJ1939 / connector M12

Flange / Shaft

- 0 Clamping flange / ø10 mm IP 54
- A Clamping flange / ø10 mm IP 65
- 1 Synchro flange / ø6 mm IP 54
- B Synchro flange / ø6 mm IP 65

Absolute encoders - modular bus covers

Shaft with clamping or synchro flange

Optical single and multiturn encoders 13 bit ST / 16 bit MT

GXAMW, GXMMW - *multivo*

Accessories

Connectors and cables

Z 119.034 Connector for data cable fibre-optic

Mounting accessories

Z 119.006 Eccentric fixing, single

Z 119.013 Adaptor plate for clamping flange for modification into synchro flange

Z 119.015 Mounting adaptor for synchro flange

Z 119.017 Mounting angle for clamping flange (M3)

Z 119.035 Bearing flange for encoders with synchro flange

Programming accessories

Z 150.022 CD with describing files & manuals

Z 139.008 Programming cable for encoders with SSI bus cover, CD with software and manual

Dimensions

GXAMW, GXMMW - clamping flange

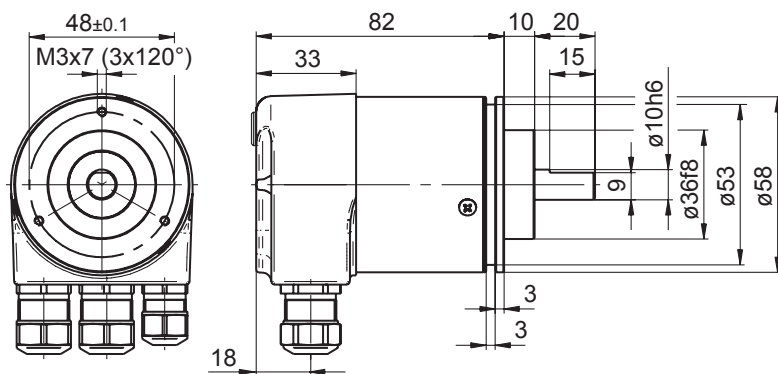

GXAMW, GXMMW - synchro flange

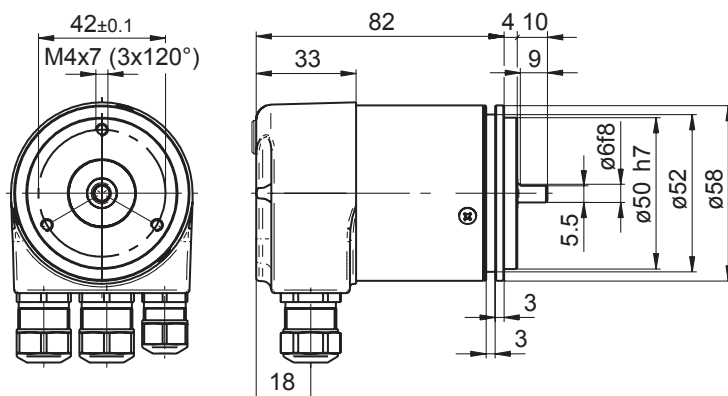

Absolute encoders - modular bus covers

Shaft with clamping or synchro flange

Optical single and multiturn encoders 13 bit ST / 16 bit MT

GXAMW, GXMMW - *multivo*

Dimensions

Profibus-DP/CANopen

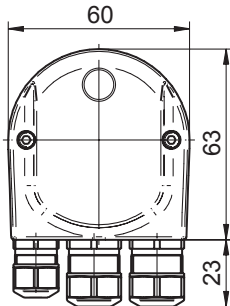

Profibus-DP - M12

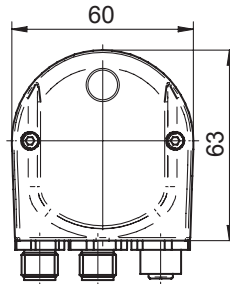

DeviceNet

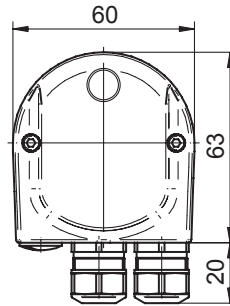

CANopen/DeviceNet M12

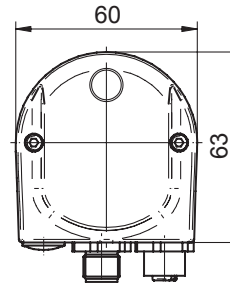

EtherCAT/EtherNet-IP

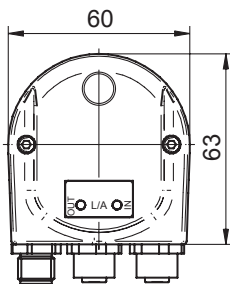

Power over EtherCAT

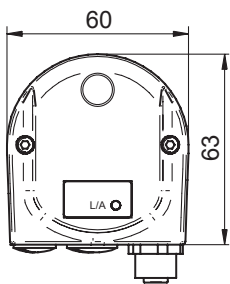

PROFINET/POWERLINK

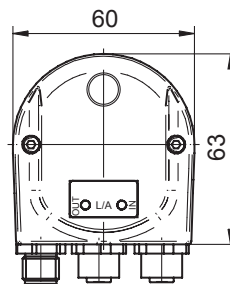

SAEJ1939

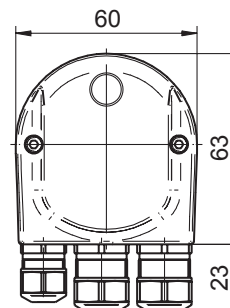

SAEJ1939 - M12

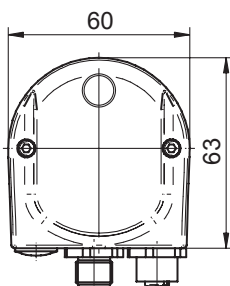

SSI

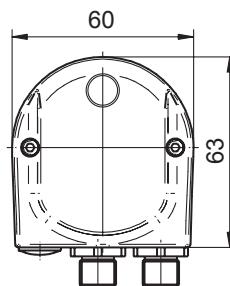

Fibre-optic

