



# STM32F101x4 STM32F101x6

Low-density access line, ARM-based 32-bit MCU with  
16 or 32 KB Flash, 5 timers, ADC and 4 communication interfaces

## Features

- Core: ARM 32-bit Cortex™-M3 CPU
  - 36 MHz maximum frequency, 1.25 DMIPS/MHz (Dhrystone 2.1) performance at 0 wait state memory access
  - Single-cycle multiplication and hardware division
- Memories
  - 16 to 32 Kbytes of Flash memory
  - 4 to 6 Kbytes of SRAM
- Clock, reset and supply management
  - 2.0 to 3.6 V application supply and I/Os
  - POR, PDR and programmable voltage detector (PVD)
  - 4-to-16 MHz crystal oscillator
  - Internal 8 MHz factory-trimmed RC
  - Internal 40 kHz RC
  - PLL for CPU clock
  - 32 kHz oscillator for RTC with calibration
- Low power
  - Sleep, Stop and Standby modes
  - V<sub>BAT</sub> supply for RTC and backup registers
- Debug mode
  - Serial wire debug (SWD) and JTAG interfaces
- DMA
  - 7-channel DMA controller
  - Peripherals supported: timers, ADC, SPIs, I<sup>2</sup>Cs and USARTs
- 1 × 12-bit, 1 μs A/D converter (up to 16 channels)
  - Conversion range: 0 to 3.6 V
  - Temperature sensor
- Up to 51 fast I/O ports
  - 26/37/51 I/Os, all mappable on 16 external interrupt vectors and almost all 5 V-tolerant

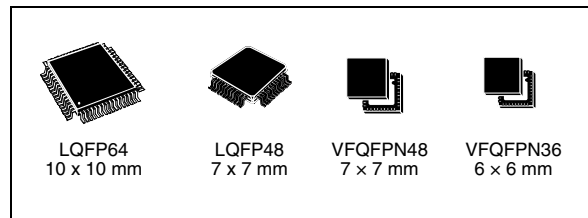

- Up to 5 timers
  - Up to two 16-bit timers, each with up to 4 IC/OC/PWM or pulse counter
  - 2 watchdog timers (Independent and Window)
  - SysTick timer: 24-bit downcounter
- Up to 4 communication interfaces
  - 1 × I<sup>2</sup>C interface (SMBus/PMBus)
  - Up to 2 USARTs (ISO 7816 interface, LIN, IrDA capability, modem control)
  - 1 × SPI (18 Mbit/s)
- CRC calculation unit, 96-bit unique ID
- ECOPACK® packages

**Table 1. Device summary**

Reference	Part number
STM32F101x4	STM32F101C4, STM32F101R4, STM32F101T4
STM32F101x6	STM32F101C6, STM32F101R6, STM32F101T6

# Contents

- 1 Introduction ..... 9**
- 2 Description ..... 10**
  - 2.1 Device overview ..... 11
  - 2.2 Full compatibility throughout the family ..... 14
  - 2.3 Overview ..... 15
    - 2.3.1 ARM® Cortex™-M3 core with embedded Flash and SRAM ..... 15
    - 2.3.2 Embedded Flash memory ..... 15
    - 2.3.3 CRC (cyclic redundancy check) calculation unit ..... 15
    - 2.3.4 Embedded SRAM ..... 15
    - 2.3.5 Nested vectored interrupt controller (NVIC) ..... 15
    - 2.3.6 External interrupt/event controller (EXTI) ..... 16
    - 2.3.7 Clocks and startup ..... 16
    - 2.3.8 Boot modes ..... 16
    - 2.3.9 Power supply schemes ..... 16
    - 2.3.10 Power supply supervisor ..... 16
    - 2.3.11 Voltage regulator ..... 17
    - 2.3.12 Low-power modes ..... 17
    - 2.3.13 DMA ..... 17
    - 2.3.14 RTC (real-time clock) and backup registers ..... 18
    - 2.3.15 Independent watchdog ..... 18
    - 2.3.16 Window watchdog ..... 18
    - 2.3.17 SysTick timer ..... 18
    - 2.3.18 General-purpose timers (TIMx) ..... 18
    - 2.3.19 I<sup>2</sup>C bus ..... 19
    - 2.3.20 Universal synchronous/asynchronous receiver transmitter (USART) .. 19
    - 2.3.21 Serial peripheral interface (SPI) ..... 19
    - 2.3.22 GPIOs (general-purpose inputs/outputs) ..... 19
    - 2.3.23 ADC (analog to digital converter) ..... 19
    - 2.3.24 Temperature sensor ..... 20
    - 2.3.25 Serial wire JTAG debug port (SWJ-DP) ..... 20
- 3 Pinouts and pin description ..... 21**



<b>4</b>	<b>Memory mapping</b> .....	<b>26</b>
<b>5</b>	<b>Electrical characteristics</b> .....	<b>27</b>
5.1	Parameter conditions .....	27
5.1.1	Minimum and maximum values .....	27
5.1.2	Typical values .....	27
5.1.3	Typical curves .....	27
5.1.4	Loading capacitor .....	27
5.1.5	Pin input voltage .....	27
5.1.6	Power supply scheme .....	28
5.1.7	Current consumption measurement .....	29
5.2	Absolute maximum ratings .....	29
5.3	Operating conditions .....	30
5.3.1	General operating conditions .....	30
5.3.2	Operating conditions at power-up / power-down .....	31
5.3.3	Embedded reset and power control block characteristics .....	31
5.3.4	Embedded reference voltage .....	33
5.3.5	Supply current characteristics .....	33
5.3.6	External clock source characteristics .....	41
5.3.7	Internal clock source characteristics .....	46
5.3.8	PLL characteristics .....	47
5.3.9	Memory characteristics .....	47
5.3.10	EMC characteristics .....	48
5.3.11	Absolute maximum ratings (electrical sensitivity) .....	50
5.3.12	I/O port characteristics .....	50
5.3.13	NRST pin characteristics .....	56
5.3.14	TIM timer characteristics .....	57
5.3.15	Communications interfaces .....	57
5.3.16	12-bit ADC characteristics .....	63
5.3.17	Temperature sensor characteristics .....	67
<b>6</b>	<b>Package characteristics</b> .....	<b>68</b>
6.1	Package mechanical data .....	68
6.2	Thermal characteristics .....	73
6.2.1	Reference document .....	73
6.2.2	Evaluating the maximum junction temperature for an application .....	74

**7      Ordering information scheme ..... 75**

**8      Revision history ..... 76**

## List of tables

Table 1.	Device summary . . . . .	1
Table 2.	Low-density STM32F101xx device features and peripheral counts . . . . .	11
Table 3.	STM32F101xx family . . . . .	14
Table 4.	Low-density STM32F101xx pin definitions . . . . .	23
Table 5.	Voltage characteristics . . . . .	29
Table 6.	Current characteristics . . . . .	30
Table 7.	Thermal characteristics . . . . .	30
Table 8.	General operating conditions . . . . .	30
Table 9.	Operating conditions at power-up / power-down . . . . .	31
Table 10.	Embedded reset and power control block characteristics . . . . .	32
Table 11.	Embedded internal reference voltage . . . . .	33
Table 12.	Maximum current consumption in Run mode, code with data processing running from Flash . . . . .	34
Table 13.	Maximum current consumption in Run mode, code with data processing running from RAM . . . . .	34
Table 14.	Maximum current consumption in Sleep mode, code running from Flash or RAM . . . . .	36
Table 15.	Typical and maximum current consumptions in Stop and Standby modes . . . . .	36
Table 16.	Typical current consumption in Run mode, code with data processing running from Flash . . . . .	39
Table 17.	Typical current consumption in Sleep mode, code running from Flash or RAM . . . . .	40
Table 18.	Peripheral current consumption . . . . .	41
Table 19.	High-speed external user clock characteristics . . . . .	42
Table 20.	Low-speed external user clock characteristics . . . . .	42
Table 21.	HSE 4-16 MHz oscillator characteristics . . . . .	44
Table 22.	LSE oscillator characteristics ( $f_{LSE} = 32.768$ kHz) . . . . .	45
Table 23.	HSI oscillator characteristics . . . . .	46
Table 24.	LSI oscillator characteristics . . . . .	46
Table 25.	Low-power mode wakeup timings . . . . .	47
Table 26.	PLL characteristics . . . . .	47
Table 27.	Flash memory characteristics . . . . .	47
Table 28.	Flash memory endurance and data retention . . . . .	48
Table 29.	EMS characteristics . . . . .	49
Table 30.	EMI characteristics . . . . .	49
Table 31.	ESD absolute maximum ratings . . . . .	50
Table 32.	Electrical sensitivities . . . . .	50
Table 33.	I/O static characteristics . . . . .	51
Table 34.	Output voltage characteristics . . . . .	54
Table 35.	I/O AC characteristics . . . . .	55
Table 36.	NRST pin characteristics . . . . .	56
Table 37.	TIMx characteristics . . . . .	57
Table 38.	I <sup>2</sup> C characteristics . . . . .	58
Table 39.	SCL frequency ( $f_{PCLK1} =$ MHz, $V_{DD} = 3.3$ V) . . . . .	59
Table 40.	SPI characteristics . . . . .	60
Table 41.	ADC characteristics . . . . .	63
Table 42.	$R_{AIN}$ max for $f_{ADC} = 14$ MHz . . . . .	64
Table 43.	ADC accuracy - limited test conditions . . . . .	64
Table 44.	ADC accuracy . . . . .	65

---

Table 45.	TS characteristics . . . . .	67
Table 46.	VFQFPN48 7 x 7 mm, 0.5 mm pitch, package mechanical data . . . . .	69
Table 47.	VFQFPN36 6 x 6 mm, 0.5 mm pitch, package mechanical data . . . . .	70
Table 48.	LQFP64 – 10 x 10 mm, 64-pin low-profile quad flat package mechanical data . . . . .	71
Table 49.	LQFP48 – 7 x 7mm, 48-pin low-profile quad flat package mechanical data . . . . .	72
Table 50.	Package thermal characteristics . . . . .	73
Table 51.	Ordering information scheme . . . . .	75
Table 52.	Document revision history . . . . .	76

## List of figures

Figure 1.	STM32F101xx Low-density access line block diagram	12
Figure 2.	Clock tree	13
Figure 3.	STM32F101xx Low-density access line LQFP64 pinout	21
Figure 4.	STM32F101xx Low-density access line LQFP48 pinout	21
Figure 5.	STM32F101xx Low-density access line VFQFPN48 pinout	22
Figure 6.	STM32F101xx Low-density access line VFQFPN36 pinout	22
Figure 7.	Memory map	26
Figure 8.	Pin loading conditions	28
Figure 9.	Pin input voltage	28
Figure 10.	Power supply scheme	28
Figure 11.	Current consumption measurement scheme	29
Figure 12.	Typical current consumption in Run mode versus frequency (at 3.6 V) - code with data processing running from RAM, peripherals enabled	35
Figure 13.	Typical current consumption in Run mode versus frequency (at 3.6 V) - code with data processing running from RAM, peripherals disabled	35
Figure 14.	Typical current consumption on V <sub>BAT</sub> with RTC on versus temperature at different V <sub>BAT</sub> values	37
Figure 15.	Typical current consumption in Stop mode with regulator in Run mode versus temperature at V <sub>DD</sub> = 3.3 V and 3.6 V	37
Figure 16.	Typical current consumption in Stop mode with regulator in Low-power mode versus temperature at V <sub>DD</sub> = 3.3 V and 3.6 V	38
Figure 17.	Typical current consumption in Standby mode versus temperature at V <sub>DD</sub> = 3.3 V and 3.6 V	38
Figure 18.	High-speed external clock source AC timing diagram	43
Figure 19.	Low-speed external clock source AC timing diagram	43
Figure 20.	Typical application with an 8 MHz crystal	44
Figure 21.	Typical application with a 32.768 kHz crystal	45
Figure 22.	Standard I/O input characteristics - CMOS port	52
Figure 23.	Standard I/O input characteristics - TTL port	52
Figure 24.	5 V tolerant I/O input characteristics - CMOS port	53
Figure 25.	5 V tolerant I/O input characteristics - TTL port	53
Figure 26.	I/O AC characteristics definition	56
Figure 27.	Recommended NRST pin protection	56
Figure 28.	I <sup>2</sup> C bus AC waveforms and measurement circuit <sup>(1)</sup>	59
Figure 29.	SPI timing diagram - slave mode and CPHA = 0	61
Figure 30.	SPI timing diagram - slave mode and CPHA = 1 <sup>(1)</sup>	61
Figure 31.	SPI timing diagram - master mode <sup>(1)</sup>	62
Figure 32.	ADC accuracy characteristics	65
Figure 33.	Typical connection diagram using the ADC	66
Figure 34.	Power supply and reference decoupling	66
Figure 35.	VFQFPN48 7 x 7 mm, 0.5 mm pitch, package outline <sup>(1)</sup>	69
Figure 36.	Recommended footprint (dimensions in mm) <sup>(1)(2)(3)</sup>	69
Figure 37.	VFQFPN36 6 x 6 mm, 0.5 mm pitch, package outline <sup>(1)</sup>	70
Figure 38.	Recommended footprint (dimensions in mm) <sup>(1)(2)(3)</sup>	70
Figure 39.	LQFP64 – 10 x 10 mm, 64 pin low-profile quad flat package outline	71
Figure 40.	Recommended footprint <sup>(1)</sup>	71
Figure 41.	LQFP48 – 7 x 7mm, 48-pin low-profile quad flat package outline	72

Figure 42. Recommended footprint<sup>(1)</sup> ..... 72  
Figure 43. LQFP64 P<sub>D</sub> max vs. T<sub>A</sub> ..... 74

# 1 Introduction

This datasheet provides the ordering information and mechanical device characteristics of the STM32F101x4 and STM32F101x6 low-density access line microcontrollers. For more details on the whole STMicroelectronics STM32F101xx family, please refer to [Section 2.2: Full compatibility throughout the family](#).

The Low-density STM32F101xx datasheet should be read in conjunction with the low-, medium- and high-density STM32F10xxx reference manual.

For information on programming, erasing and protection of the internal Flash memory please refer to the *STM32F10xxx Flash programming manual*.

The reference and Flash programming manuals are both available from the STMicroelectronics website [www.st.com](http://www.st.com).

For information on the Cortex™-M3 core please refer to the Cortex™-M3 Technical Reference Manual, available from the [www.arm.com](http://www.arm.com) website at the following address: <http://infocenter.arm.com/help/index.jsp?topic=/com.arm.doc.ddi0337e/>.



## 2 Description

The STM32F101x4 and STM32F101x6 Low-density access line family incorporates the high-performance ARM Cortex™-M3 32-bit RISC core operating at a 36 MHz frequency, high-speed embedded memories (Flash memory of 16 to 32 Kbytes and SRAM of 4 to 6 Kbytes), and an extensive range of enhanced peripherals and I/Os connected to two APB buses. All devices offer standard communication interfaces (one I<sup>2</sup>C, one SPI, and two USARTs), one 12-bit ADC and up to two general-purpose 16-bit timers.

The STM32F101xx Low-density access line family operates in the –40 to +85 °C temperature range, from a 2.0 to 3.6 V power supply. A comprehensive set of power-saving mode allows the design of low-power applications.

The STM32F101xx Low-density access line family includes devices in three different packages ranging from 36 pins to 64 pins. Depending on the device chosen, different sets of peripherals are included, the description below gives an overview of the complete range of peripherals proposed in this family.

These features make the STM32F101xx Low-density access line microcontroller family suitable for a wide range of applications:

- Application control and user interface
- Medical and handheld equipment
- PC peripherals, gaming and GPS platforms
- Industrial applications: PLC, inverters, printers, and scanners
- Alarm systems, Video intercom, and HVAC

*Figure 1* shows the general block diagram of the device family.

## 2.1 Device overview

Table 2. Low-density STM32F101xx device features and peripheral counts

Peripheral		STM32F101Tx		STM32F101Cx		STM32F101Rx	
Flash - Kbytes		16	32	16	32	16	32
SRAM - Kbytes		4	6	4	6	4	6
Timers	General-purpose	2	2	2	2	2	2
	Communication						
	SPI	1	1	1	1	1	1
	I <sup>2</sup> C	1	1	1	1	1	1
	USART	2	2	2	2	2	2
12-bit synchronized ADC number of channels		1 10 channels		1 10 channels		1 16 channels	
GPIOs		26		37		51	
CPU frequency		36 MHz					
Operating voltage		2.0 to 3.6 V					
Operating temperatures		Ambient temperature: -40 to +85 °C (see <a href="#">Table 8</a> ) Junction temperature: -40 to +105 °C (see <a href="#">Table 8</a> )					
Packages		VFQFPN36		LQFP48, VFQFPN48		LQFP64	

Figure 1. STM32F101xx Low-density access line block diagram

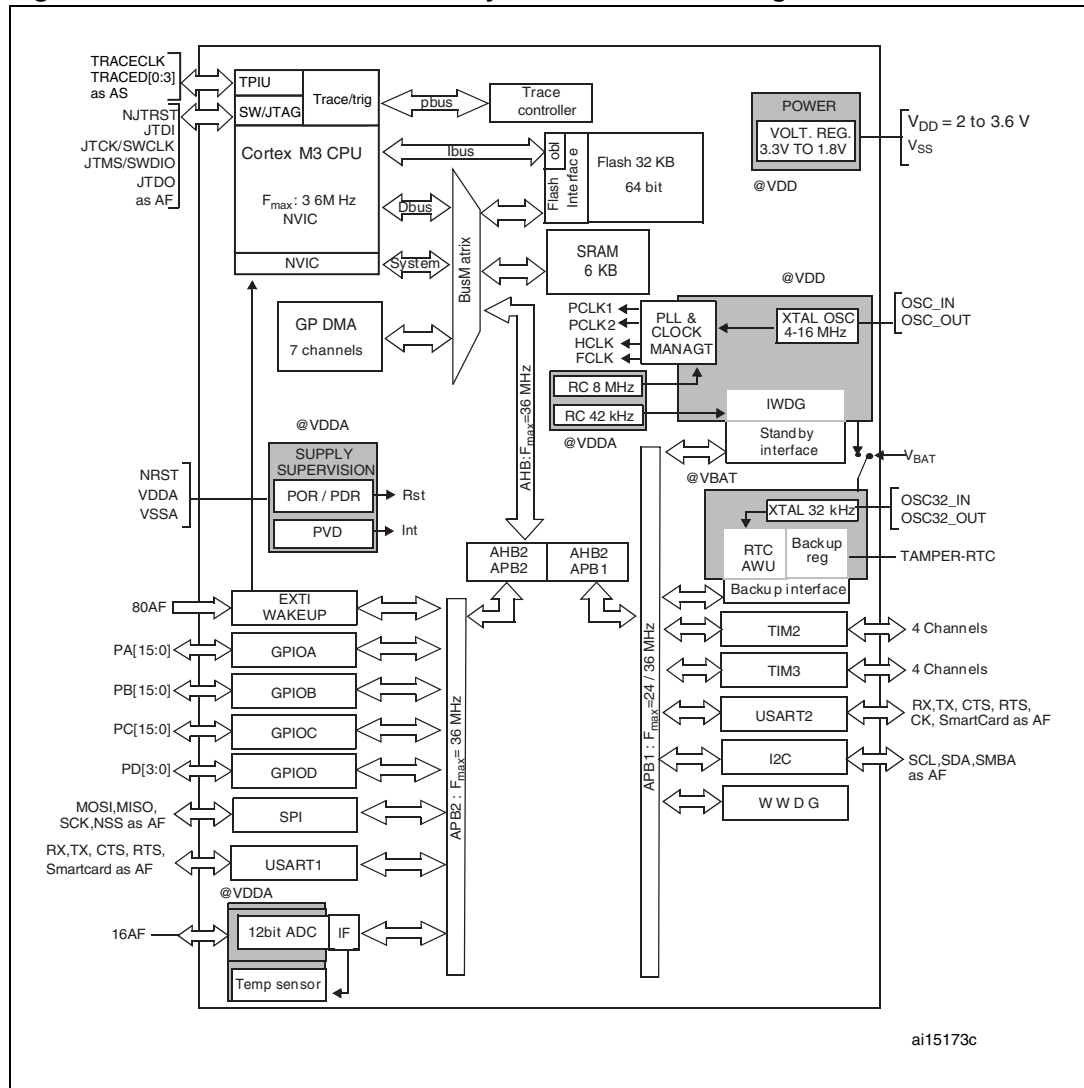

1. AF = alternate function on I/O port pin.
2.  $T_A = -40\text{ }^\circ\text{C}$  to  $+85\text{ }^\circ\text{C}$  (junction temperature up to  $105\text{ }^\circ\text{C}$ ).

Figure 2. Clock tree

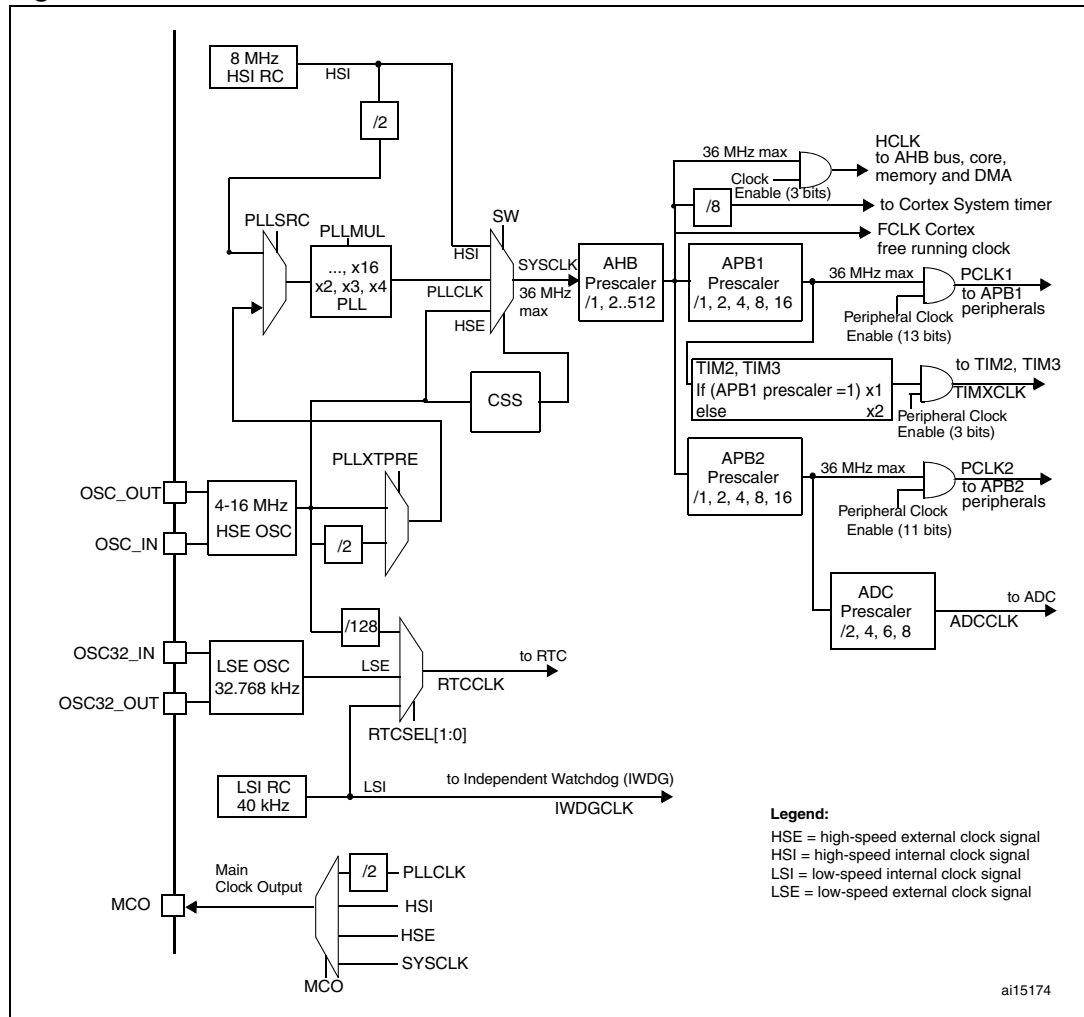

1. When the HSI is used as a PLL clock input, the maximum system clock frequency that can be achieved is 36 MHz.
2. To have an ADC conversion time of 1  $\mu$ s, APB2 must be at 14 MHz or 28 MHz.

## 2.2 Full compatibility throughout the family

The STM32F101xx is a complete family whose members are fully pin-to-pin, software and feature compatible. In the reference manual, the STM32F101x4 and STM32F101x6 are referred to as low-density devices, the STM32F101x8 and STM32F101xB are referred to as medium-density devices, and the STM32F101xC, STM32F101xD and STM32F101xE are referred to as high-density devices.

Low- and high-density devices are an extension of the STM32F101x8/B devices, they are specified in the STM32F101x4/6 and STM32F101xC/D/E datasheets, respectively. Low-density devices feature lower Flash memory and RAM capacities and a timer less. High-density devices have higher Flash memory and RAM capacities, and additional peripherals like FSMC and DAC, while remaining fully compatible with the other members of the STM32F101xx family.

The STM32F101x4, STM32F101x6, STM32F101xC, STM32F101xD and STM32F101xE are a drop-in replacement for the STM32F101x8/B medium-density devices, allowing the user to try different memory densities and providing a greater degree of freedom during the development cycle.

Moreover, the STM32F101xx performance line family is fully compatible with all existing STM32F101xx access line and STM32F102xx USB access line devices.

**Table 3. STM32F101xx family**

Pinout	Memory size									
	Low-density devices		Medium-density devices		High-density devices					
	16 KB Flash	32 KB Flash <sup>(1)</sup>	64 KB Flash	128 KB Flash	256 KB Flash	384 KB Flash	512 KB Flash			
	4 KB RAM	6 KB RAM	10 KB RAM	16 KB RAM	32 KB RAM	48 KB RAM	48 KB RAM			
144					5 × USARTs 4 × 16-bit timers, 2 × basic timers 3 × SPIs, 2 × I <sup>2</sup> Cs, 1 × ADC, 2 × DACs, FSMC (100 and 144 pins)					
100										
64	2 × USARTs 2 × 16-bit timers 1 × SPI, 1 × I <sup>2</sup> C 1 × ADC		3 × USARTs 3 × 16-bit timers 2 × SPIs, 2 × I <sup>2</sup> Cs, 1 × ADC							
48										
36										

1. For orderable part numbers that do not show the A internal code after the temperature range code (6), the reference datasheet for electrical characteristics is that of the STM32F101x8/B medium-density devices.

## 2.3 Overview

### 2.3.1 ARM® Cortex™-M3 core with embedded Flash and SRAM

The ARM Cortex™-M3 processor is the latest generation of ARM processors for embedded systems. It has been developed to provide a low-cost platform that meets the needs of MCU implementation, with a reduced pin count and low-power consumption, while delivering outstanding computational performance and an advanced system response to interrupts.

The ARM Cortex™-M3 32-bit RISC processor features exceptional code-efficiency, delivering the high-performance expected from an ARM core in the memory size usually associated with 8- and 16-bit devices.

The STM32F101xx Low-density access line family having an embedded ARM core, is therefore compatible with all ARM tools and software.

### 2.3.2 Embedded Flash memory

16 or 32 Kbytes of embedded Flash is available for storing programs and data.

### 2.3.3 CRC (cyclic redundancy check) calculation unit

The CRC (cyclic redundancy check) calculation unit is used to get a CRC code from a 32-bit data word and a fixed generator polynomial.

Among other applications, CRC-based techniques are used to verify data transmission or storage integrity. In the scope of the EN/IEC 60335-1 standard, they offer a means of verifying the Flash memory integrity. The CRC calculation unit helps compute a signature of the software during runtime, to be compared with a reference signature generated at link-time and stored at a given memory location.

### 2.3.4 Embedded SRAM

Up to 6 Kbytes of embedded SRAM accessed (read/write) at CPU clock speed with 0 wait states.

### 2.3.5 Nested vectored interrupt controller (NVIC)

The STM32F101xx Low-density access line embeds a nested vectored interrupt controller able to handle up to 43 maskable interrupt channels (not including the 16 interrupt lines of Cortex™-M3) and 16 priority levels.

- Closely coupled NVIC gives low latency interrupt processing
- Interrupt entry vector table address passed directly to the core
- Closely coupled NVIC core interface
- Allows early processing of interrupts
- Processing of *late arriving* higher priority interrupts
- Support for tail-chaining
- Processor state automatically saved
- Interrupt entry restored on interrupt exit with no instruction overhead

This hardware block provides flexible interrupt management features with minimal interrupt latency.

### 2.3.6 External interrupt/event controller (EXTI)

The external interrupt/event controller consists of 19 edge detector lines used to generate interrupt/event requests. Each line can be independently configured to select the trigger event (rising edge, falling edge, both) and can be masked independently. A pending register maintains the status of the interrupt requests. The EXTI can detect an external line with a pulse width shorter than the Internal APB2 clock period. Up to 80 GPIOs can be connected to the 16 external interrupt lines.

### 2.3.7 Clocks and startup

System clock selection is performed on startup, however the internal RC 8 MHz oscillator is selected as default CPU clock on reset. An external 4-16 MHz clock can be selected, in which case it is monitored for failure. If failure is detected, the system automatically switches back to the internal RC oscillator. A software interrupt is generated if enabled. Similarly, full interrupt management of the PLL clock entry is available when necessary (for example on failure of an indirectly used external crystal, resonator or oscillator).

Several prescalers allow the configuration of the AHB frequency, the high-speed APB (APB2) and the low-speed APB (APB1) domains. The maximum frequency of the AHB and the APB domains is 36 MHz. See [Figure 2](#) for details on the clock tree.

### 2.3.8 Boot modes

At startup, boot pins are used to select one of three boot options:

- Boot from User Flash
- Boot from System Memory
- Boot from embedded SRAM

The boot loader is located in System Memory. It is used to reprogram the Flash memory by using USART1. For further details please refer to AN2606.

### 2.3.9 Power supply schemes

- $V_{DD} = 2.0$  to  $3.6$  V: External power supply for I/Os and the internal regulator. Provided externally through  $V_{DD}$  pins.
- $V_{SSA}$ ,  $V_{DDA} = 2.0$  to  $3.6$  V: External analog power supplies for ADC, Reset blocks, RCs and PLL (minimum voltage to be applied to  $V_{DDA}$  is  $2.4$  V when the ADC is used).  $V_{DDA}$  and  $V_{SSA}$  must be connected to  $V_{DD}$  and  $V_{SS}$ , respectively.
- $V_{BAT} = 1.8$  to  $3.6$  V: Power supply for RTC, external clock 32 kHz oscillator and backup registers (through power switch) when  $V_{DD}$  is not present.

For more details on how to connect power pins, refer to [Figure 10: Power supply scheme](#).

### 2.3.10 Power supply supervisor

The device has an integrated power on reset (POR)/power down reset (PDR) circuitry. It is always active, and ensures proper operation starting from/down to 2 V. The device remains in reset mode when  $V_{DD}$  is below a specified threshold,  $V_{POR/PDR}$ , without the need for an external reset circuit.

The device features an embedded programmable voltage detector (PVD) that monitors the  $V_{DD}/V_{DDA}$  power supply and compares it to the  $V_{PVD}$  threshold. An interrupt can be generated when  $V_{DD}/V_{DDA}$  drops below the  $V_{PVD}$  threshold and/or when  $V_{DD}/V_{DDA}$  is higher

than the  $V_{PVD}$  threshold. The interrupt service routine can then generate a warning message and/or put the MCU into a safe state. The PVD is enabled by software.

Refer to [Table 10: Embedded reset and power control block characteristics](#) for the values of  $V_{POR/PDR}$  and  $V_{PVD}$ .

### 2.3.11 Voltage regulator

The regulator has three operation modes: main (MR), low power (LPR) and power down.

- MR is used in the nominal regulation mode (Run)
- LPR is used in the Stop mode
- Power down is used in Standby mode: the regulator output is in high impedance: the kernel circuitry is powered down, inducing zero consumption (but the contents of the registers and SRAM are lost)

This regulator is always enabled after reset. It is disabled in Standby mode, providing high impedance output.

### 2.3.12 Low-power modes

The STM32F101xx Low-density access line supports three low-power modes to achieve the best compromise between low power consumption, short startup time and available wakeup sources:

- **Sleep mode**  
In Sleep mode, only the CPU is stopped. All peripherals continue to operate and can wake up the CPU when an interrupt/event occurs.
- **Stop mode**  
Stop mode achieves the lowest power consumption while retaining the content of SRAM and registers. All clocks in the 1.8 V domain are stopped, the PLL, the HSI RC and the HSE crystal oscillators are disabled. The voltage regulator can also be put either in normal or in low power mode.  
The device can be woken up from Stop mode by any of the EXTI line. The EXTI line source can be one of the 16 external lines, the PVD output or the RTC alarm.
- **Standby mode**  
The Standby mode is used to achieve the lowest power consumption. The internal voltage regulator is switched off so that the entire 1.8 V domain is powered off. The PLL, the HSI RC and the HSE crystal oscillators are also switched off. After entering Standby mode, SRAM and register contents are lost except for registers in the Backup domain and Standby circuitry.  
The device exits Standby mode when an external reset (NRST pin), a IWDG reset, a rising edge on the WKUP pin, or an RTC alarm occurs.

*Note:* The RTC, the IWDG, and the corresponding clock sources are not stopped by entering Stop or Standby mode.

### 2.3.13 DMA

The flexible 7-channel general-purpose DMA is able to manage memory-to-memory, peripheral-to-memory and memory-to-peripheral transfers. The DMA controller supports circular buffer management avoiding the generation of interrupts when the controller reaches the end of the buffer.

Each channel is connected to dedicated hardware DMA requests, with support for software trigger on each channel. Configuration is made by software and transfer sizes between source and destination are independent.

The DMA can be used with the main peripherals: SPI, I<sup>2</sup>C, USART, general purpose timers TIMx and ADC.

### 2.3.14 RTC (real-time clock) and backup registers

The RTC and the backup registers are supplied through a switch that takes power either on V<sub>DD</sub> supply when present or through the V<sub>BAT</sub> pin. The backup registers are ten 16-bit registers used to store 20 bytes of user application data when V<sub>DD</sub> power is not present.

The real-time clock provides a set of continuously running counters which can be used with suitable software to provide a clock calendar function, and provides an alarm interrupt and a periodic interrupt. It is clocked by a 32.768 kHz external crystal, resonator or oscillator, the internal low power RC oscillator or the high-speed external clock divided by 128. The internal low power RC has a typical frequency of 40 kHz. The RTC can be calibrated using an external 512 Hz output to compensate for any natural crystal deviation. The RTC features a 32-bit programmable counter for long term measurement using the Compare register to generate an alarm. A 20-bit prescaler is used for the time base clock and is by default configured to generate a time base of 1 second from a clock at 32.768 kHz.

### 2.3.15 Independent watchdog

The independent watchdog is based on a 12-bit downcounter and 8-bit prescaler. It is clocked from an independent 40 kHz internal RC and as it operates independently from the main clock, it can operate in Stop and Standby modes. It can be used as a watchdog to reset the device when a problem occurs, or as a free running timer for application timeout management. It is hardware or software configurable through the option bytes. The counter can be frozen in debug mode.

### 2.3.16 Window watchdog

The window watchdog is based on a 7-bit downcounter that can be set as free running. It can be used as a watchdog to reset the device when a problem occurs. It is clocked from the main clock. It has an early warning interrupt capability and the counter can be frozen in debug mode.

### 2.3.17 SysTick timer

This timer is dedicated for OS, but could also be used as a standard down counter. It features:

- A 24-bit down counter
- Autoreload capability
- Maskable system interrupt generation when the counter reaches 0.
- Programmable clock source

### 2.3.18 General-purpose timers (TIMx)

There are up to two synchronizable general-purpose timers embedded in the STM32F101xx Low-density access line devices. These timers are based on a 16-bit auto-reload up/down counter, a 16-bit prescaler and feature 4 independent channels each for input capture,

output compare, PWM or one pulse mode output. This gives up to 12 input captures / output compares / PWMs on the largest packages.

The general-purpose timers can work together via the Timer Link feature for synchronization or event chaining. Their counter can be frozen in debug mode. Any of the general-purpose timers can be used to generate PWM outputs. They all have independent DMA request generation.

These timers are capable of handling quadrature (incremental) encoder signals and the digital outputs from 1 to 3 hall-effect sensors.

### 2.3.19 I<sup>2</sup>C bus

The I<sup>2</sup>C bus interface can operate in multimaster and slave modes. It can support standard and fast modes.

It supports dual slave addressing (7-bit only) and both 7/10-bit addressing in master mode. A hardware CRC generation/verification is embedded.

The interface can be served by DMA and it supports SM Bus 2.0/PM Bus.

### 2.3.20 Universal synchronous/asynchronous receiver transmitter (USART)

The available USART interfaces communicate at up to 2.25 Mbit/s. They provide hardware management of the CTS and RTS signals, support IrDA SIR ENDEC, are ISO 7816 compliant and have LIN Master/Slave capability.

The USART interfaces can be served by the DMA controller.

### 2.3.21 Serial peripheral interface (SPI)

The SPI interface is able to communicate up to 18 Mbit/s in slave and master modes in full-duplex and simplex communication modes. The 3-bit prescaler gives 8 master mode frequencies and the frame is configurable to 8 bits or 16 bits. The hardware CRC generation/verification supports basic SD Card/MMC modes.

The SPI interface can be served by the DMA controller.

### 2.3.22 GPIOs (general-purpose inputs/outputs)

Each of the GPIO pins can be configured by software as output (push-pull or open-drain), as input (with or without pull-up or pull-down) or as peripheral alternate function. Most of the GPIO pins are shared with digital or analog alternate functions. All GPIOs are high current-capable except for analog inputs.

The I/Os alternate function configuration can be locked if needed following a specific sequence in order to avoid spurious writing to the I/Os registers.

### 2.3.23 ADC (analog to digital converter)

The 12-bit analog to digital converter has up to 16 external channels and performs conversions in single-shot or scan modes. In scan mode, automatic conversion is performed on a selected group of analog inputs.

The ADC can be served by the DMA controller.

An analog watchdog feature allows very precise monitoring of the converted voltage of one, some or all selected channels. An interrupt is generated when the converted voltage is outside the programmed thresholds.

### 2.3.24 Temperature sensor

The temperature sensor has to generate a voltage that varies linearly with temperature. The conversion range is between  $2\text{ V} < V_{\text{DDA}} < 3.6\text{ V}$ . The temperature sensor is internally connected to the ADC\_IN16 input channel which is used to convert the sensor output voltage into a digital value.

### 2.3.25 Serial wire JTAG debug port (SWJ-DP)

The ARM SWJ-DP Interface is embedded, and is a combined JTAG and serial wire debug port that enables either a serial wire debug or a JTAG probe to be connected to the target. The JTAG TMS and TCK pins are shared respectively with SWDIO and SWCLK and a specific sequence on the TMS pin is used to switch between JTAG-DP and SW-DP.

### 3 Pinouts and pin description

Figure 3. STM32F101xx Low-density access line LQFP64 pinout

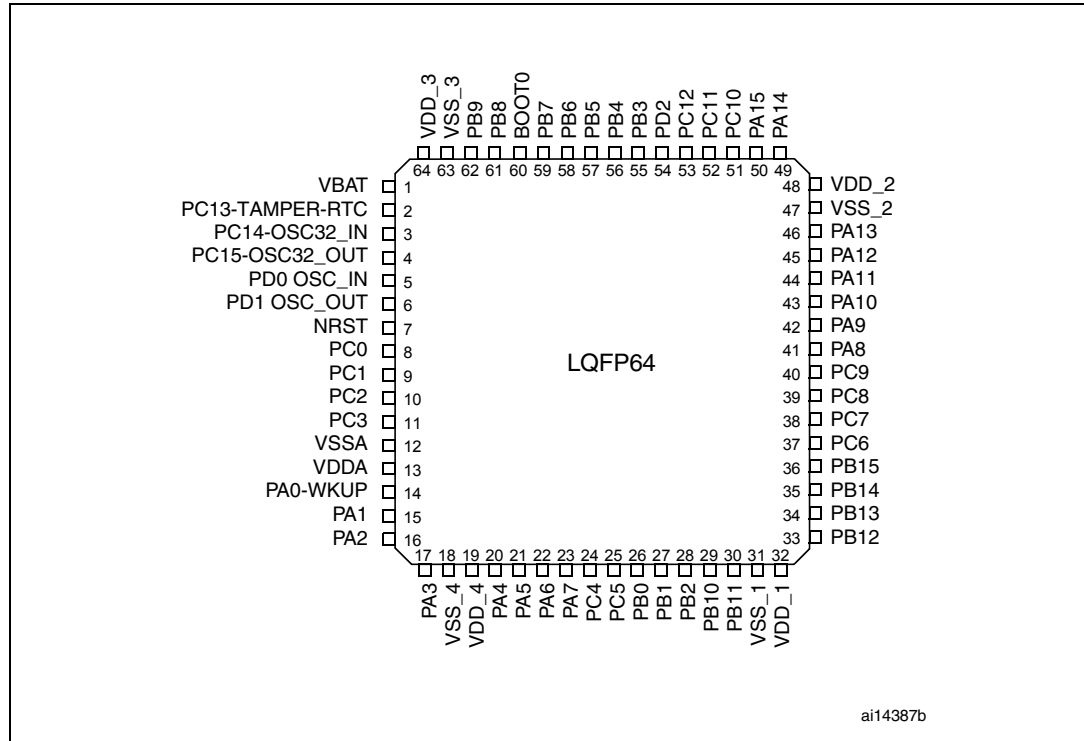

ai14387b

Figure 4. STM32F101xx Low-density access line LQFP48 pinout

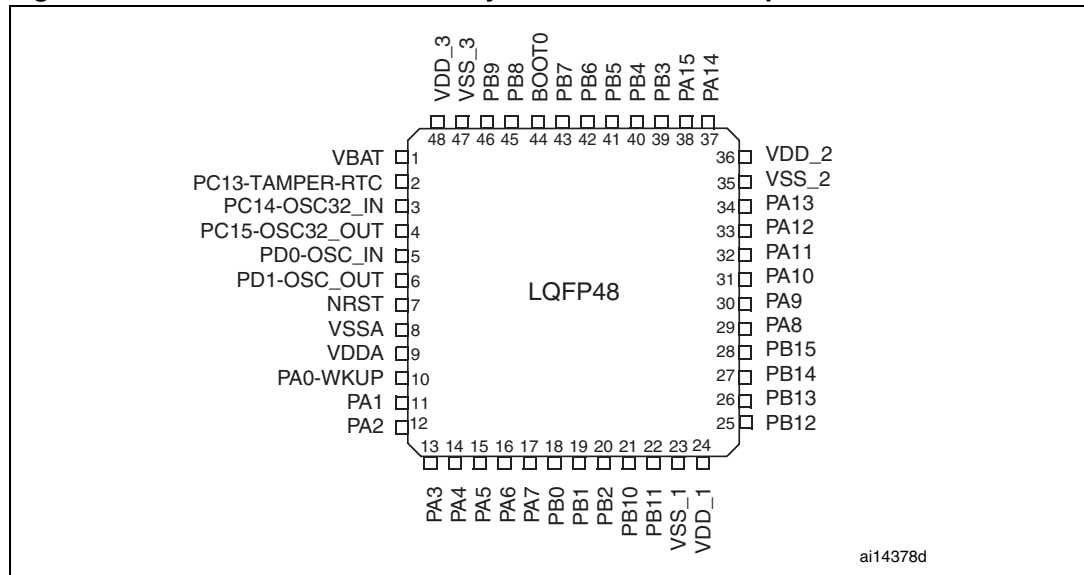

ai14378d

Figure 5. STM32F101xx Low-density access line VFQFPN48 pinout

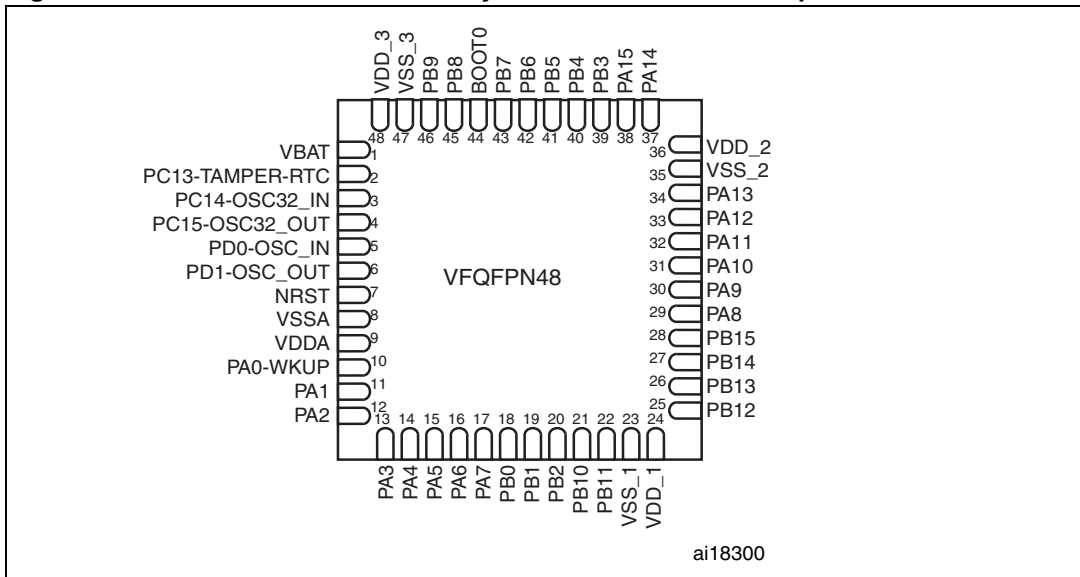

Figure 6. STM32F101xx Low-density access line VFQFPN36 pinout

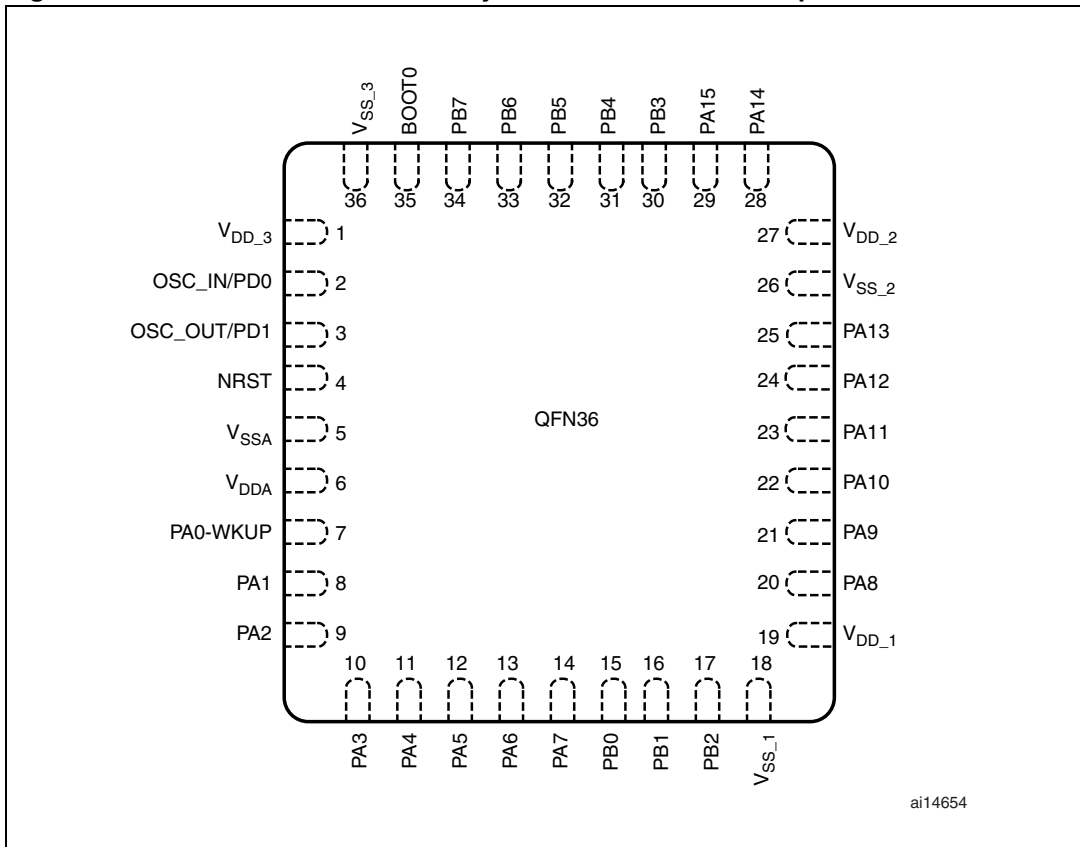

Table 4. Low-density STM32F101xx pin definitions

Pins			Pin name	Type <sup>(1)</sup>	I/O level <sup>(2)</sup>	Main function <sup>(3)</sup> (after reset)	Alternate functions <sup>(3)(4)</sup>	
LQFP48/ VFQFPN48	LQFP64	VFQFPN36					Default	Remap
1	1	-	V <sub>BAT</sub>	S		V <sub>BAT</sub>		
2	2	-	PC13-TAMPER-RTC <sup>(5)</sup>	I/O		PC13 <sup>(6)</sup>	TAMPER-RTC	
3	3	-	PC14-OSC32_IN <sup>(5)</sup>	I/O		PC14 <sup>(6)</sup>	OSC32_IN	
4	4	-	PC15-OSC32_OUT <sup>(5)</sup>	I/O		PC15 <sup>(6)</sup>	OSC32_OUT	
5	5	2	OSC_IN	I		OSC_IN		
6	6	3	OSC_OUT	O		OSC_OUT		
7	7	4	NRST	I/O		NRST		
-	8	-	PC0	I/O		PC0	ADC_IN10	
-	9	-	PC1	I/O		PC1	ADC_IN11	
-	10	-	PC2	I/O		PC2	ADC_IN12	
-	11	-	PC3	I/O		PC3	ADC_IN13	
8	12	5	V <sub>SSA</sub>	S		V <sub>SSA</sub>		
9	13	6	V <sub>DDA</sub>	S		V <sub>DDA</sub>		
10	14	7	PA0-WKUP	I/O		PA0	WKUP/USART2_CTS/ ADC_IN0/ TIM2_CH1_ETR <sup>(7)</sup>	
11	15	8	PA1	I/O		PA1	USART2_RTS/ ADC_IN1/TIM2_CH2 <sup>(7)</sup>	
12	16	9	PA2	I/O		PA2	USART2_TX/ ADC_IN2/TIM2_CH3 <sup>(7)</sup>	
13	17	10	PA3	I/O		PA3	USART2_RX/ ADC_IN3/TIM2_CH4 <sup>(7)</sup>	
-	18	-	V <sub>SS_4</sub>	S		V <sub>SS_4</sub>		
-	19	-	V <sub>DD_4</sub>	S		V <sub>DD_4</sub>		
14	20	11	PA4	I/O		PA4	SPI_NSS <sup>(7)</sup> /ADC_IN4 USART2_CK	
15	21	12	PA5	I/O		PA5	SPI_SCK <sup>(7)</sup> /ADC_IN5	
16	22	13	PA6	I/O		PA6	SPI_MISO <sup>(7)</sup> /ADC_IN6/ TIM3_CH1 <sup>(7)</sup>	
17	23	14	PA7	I/O		PA7	SPI_MOSI <sup>(7)</sup> /ADC_IN7/ TIM3_CH2 <sup>(7)</sup>	
-	24		PC4	I/O		PC4	ADC_IN14	
-	25		PC5	I/O		PC5	ADC_IN15	
18	26	15	PB0	I/O		PB0	ADC_IN8/TIM3_CH3 <sup>(7)</sup>	
19	27	16	PB1	I/O		PB1	ADC_IN9/TIM3_CH4 <sup>(7)</sup>	

Table 4. Low-density STM32F101xx pin definitions (continued)

Pins			Pin name	Type <sup>(1)</sup>	I / O level <sup>(2)</sup>	Main function <sup>(3)</sup> (after reset)	Alternate functions <sup>(3)(4)</sup>	
LQFP48/ VFQFPN48	LQFP64	VFQFPN36					Default	Remap
20	28	17	PB2	I/O	FT	PB2/BOOT1		
21	29	-	PB10	I/O	FT	PB10		TIM2_CH3
22	30	-	PB11	I/O	FT	PB11		TIM2_CH4
23	31	18	V <sub>SS_1</sub>	S		V <sub>SS_1</sub>		
24	32	19	V <sub>DD_1</sub>	S		V <sub>DD_1</sub>		
25	33	-	PB12	I/O	FT	PB12		
26	34	-	PB13	I/O	FT	PB13		
27	35	-	PB14	I/O	FT	PB14		
28	36	-	PB15	I/O	FT	PB15		
-	37	-	PC6	I/O	FT	PC6		TIM3_CH1
	38	-	PC7	I/O	FT	PC7		TIM3_CH2
	39	-	PC8	I/O	FT	PC8		TIM3_CH3
-	40	-	PC9	I/O	FT	PC9		TIM3_CH4
29	41	20	PA8	I/O	FT	PA8	USART1_CK/MCO	
30	42	21	PA9	I/O	FT	PA9	USART1_TX <sup>(7)</sup>	
31	43	22	PA10	I/O	FT	PA10	USART1_RX <sup>(7)</sup>	
32	44	23	PA11	I/O	FT	PA11	USART1_CTS	
33	45	24	PA12	I/O	FT	PA12	USART1_RTS	
34	46	25	PA13	I/O	FT	JTMS-SWDIO		PA13
35	47	26	V <sub>SS_2</sub>	S		V <sub>SS_2</sub>		
36	48	27	V <sub>DD_2</sub>	S		V <sub>DD_2</sub>		
37	49	28	PA14	I/O	FT	JTCK/SWCLK		PA14
38	50	29	PA15	I/O	FT	JTDI		TIM2_CH1_ETR/ PA15 / SPI_NSS
-	51		PC10	I/O	FT	PC10		
-	52		PC11	I/O	FT	PC11		
-	53		PC12	I/O	FT	PC12		
5	5	2	PD0	I/O	FT	OSC_IN <sup>(8)</sup>		
6	6	3	PD1	I/O	FT	OSC_OUT <sup>(8)</sup>		
	54	-	PD2	I/O	FT	PD2	TIM3_ETR	
39	55	30	PB3	I/O	FT	JTDO		TIM2_CH2 / PB3 TRACESWO SPI_SCK

**Table 4. Low-density STM32F101xx pin definitions (continued)**

Pins			Pin name	Type <sup>(1)</sup>	I / O level <sup>(2)</sup>	Main function <sup>(3)</sup> (after reset)	Alternate functions <sup>(3)(4)</sup>	
LQFP48/ VFQFPN48	LQFP64	VFQFPN36					Default	Remap
40	56	31	PB4	I/O	FT	NJTRST		TIM3_CH1 / PB4 SPI_MISO
41	57	32	PB5	I/O		PB5	I2C_SMBA	TIM3_CH2 / SPI_MOSI
42	58	33	PB6	I/O	FT	PB6	I2C_SCL <sup>(7)</sup>	USART1_TX
43	59	34	PB7	I/O	FT	PB7	I2C_SDA <sup>(7)</sup>	USART1_RX
44	60	35	BOOT0	I		BOOT0		
45	61	-	PB8	I/O	FT	PB8		I2C_SCL
46	62	-	PB9	I/O	FT	PB9		I2C_SDA
47	63	36	V <sub>SS_3</sub>	S		V <sub>SS_3</sub>		
48	64	1	V <sub>DD_3</sub>	S		V <sub>DD_3</sub>		

1. I = input, O = output, S = supply.
2. FT= 5 V tolerant.
3. Function availability depends on the chosen device. For devices having reduced peripheral counts, it is always the lower number of peripherals that is included. For example, if a device has only one SPI, two USARTs and two timers, they will be called SPI, USART1 & USART2 and TIM2 & TIM 3, respectively. Refer to [Table 2 on page 11](#).
4. If several peripherals share the same I/O pin, to avoid conflict between these alternate functions only one peripheral should be enabled at a time through the peripheral clock enable bit (in the corresponding RCC peripheral clock enable register).
5. PC13, PC14 and PC15 are supplied through the power switch. Since the switch only sinks a limited amount of current (3 mA), the use of GPIOs PC13 to PC15 in output mode is limited: the speed should not exceed 2 MHz with a maximum load of 30 pF and these IOs must not be used as a current source (e.g. to drive an LED).
6. Main function after the first backup domain power-up. Later on, it depends on the contents of the Backup registers even after reset (because these registers are not reset by the main reset). For details on how to manage these IOs, refer to the Battery backup domain and BKP register description sections in the STM32F10xx reference manual, available from the STMicroelectronics website: [www.st.com](http://www.st.com).
7. This alternate function can be remapped by software to some other port pins (if available on the used package). For more details, refer to the Alternate function I/O and debug configuration section in the STM32F10xxx reference manual, available from the STMicroelectronics website: [www.st.com](http://www.st.com).
8. The pins number 2 and 3 in the VFQFPN36 package, and 5 and 6 in the LQFP48 and LQFP64 packages are configured as OSC\_IN/OSC\_OUT after reset, however the functionality of PD0 and PD1 can be remapped by software on these pins. For more details, refer to the Alternate function I/O and debug configuration section in the STM32F10xxx reference manual.

# 4 Memory mapping

The memory map is shown in *Figure 7*.

**Figure 7. Memory map**

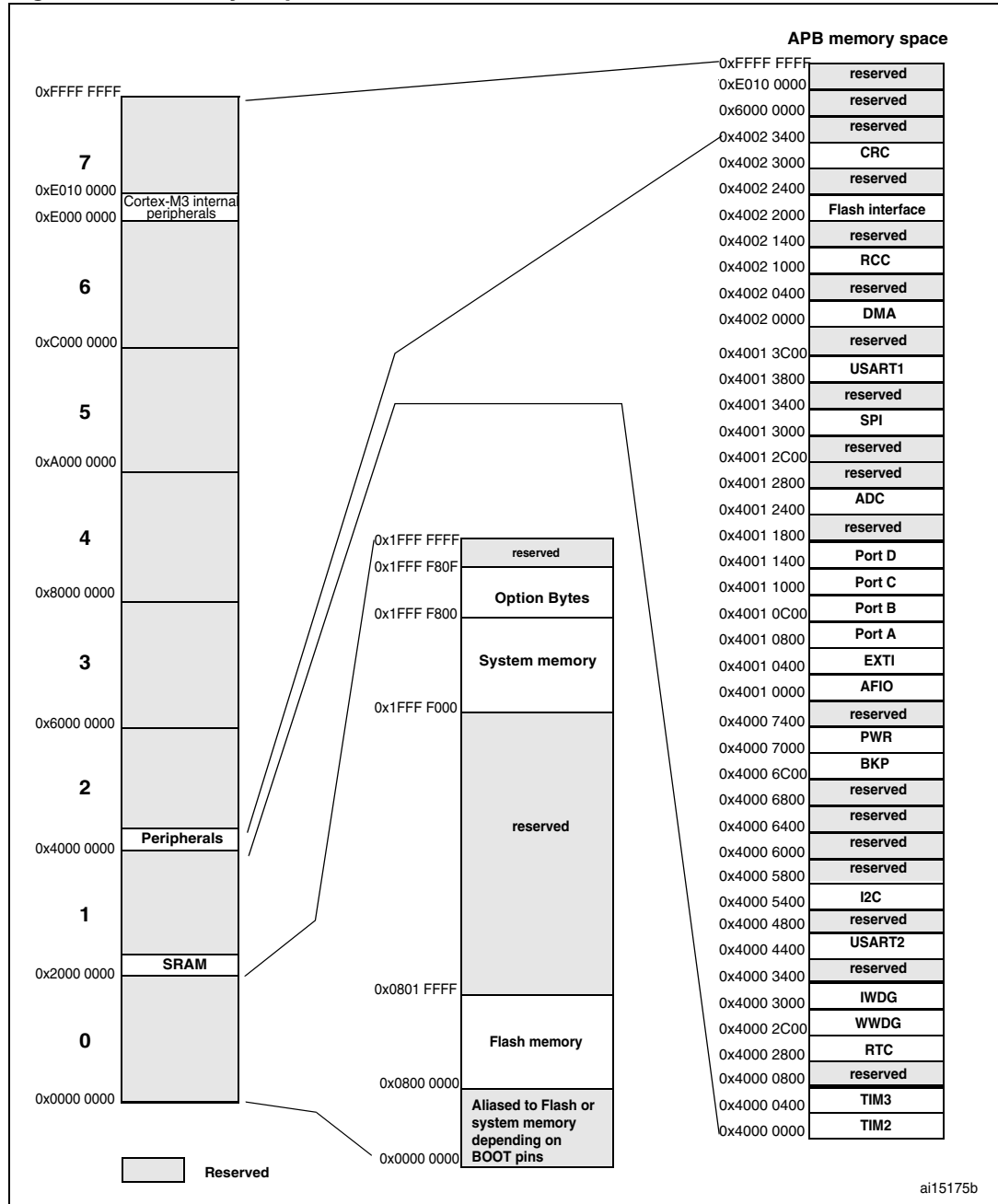

## 5 Electrical characteristics

### 5.1 Parameter conditions

Unless otherwise specified, all voltages are referenced to  $V_{SS}$ .

#### 5.1.1 Minimum and maximum values

Unless otherwise specified the minimum and maximum values are guaranteed in the worst conditions of ambient temperature, supply voltage and frequencies by tests in production on 100% of the devices with an ambient temperature at  $T_A = 25\text{ °C}$  and  $T_A = T_{A\text{max}}$  (given by the selected temperature range).

Data based on characterization results, design simulation and/or technology characteristics are indicated in the table footnotes and are not tested in production. Based on characterization, the minimum and maximum values refer to sample tests and represent the mean value plus or minus three times the standard deviation ( $\text{mean} \pm 3\Sigma$ ).

#### 5.1.2 Typical values

Unless otherwise specified, typical data are based on  $T_A = 25\text{ °C}$ ,  $V_{DD} = 3.3\text{ V}$  (for the  $2\text{ V} \leq V_{DD} \leq 3.6\text{ V}$  voltage range). They are given only as design guidelines and are not tested.

Typical ADC accuracy values are determined by characterization of a batch of samples from a standard diffusion lot over the full temperature range, where 95% of the devices have an error less than or equal to the value indicated ( $\text{mean} \pm 2\Sigma$ ).

#### 5.1.3 Typical curves

Unless otherwise specified, all typical curves are given only as design guidelines and are not tested.

#### 5.1.4 Loading capacitor

The loading conditions used for pin parameter measurement are shown in [Figure 8](#).

#### 5.1.5 Pin input voltage

The input voltage measurement on a pin of the device is described in [Figure 9](#).

Figure 8. Pin loading conditions

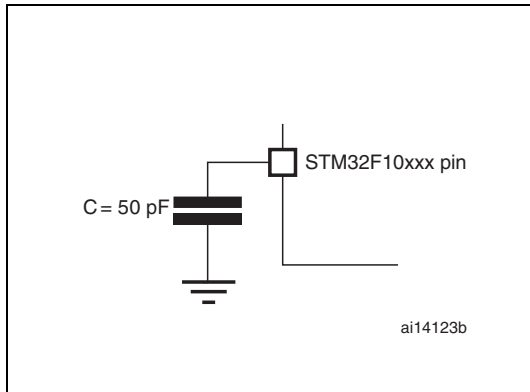
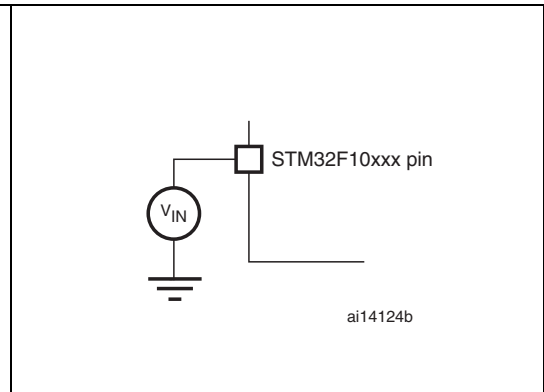
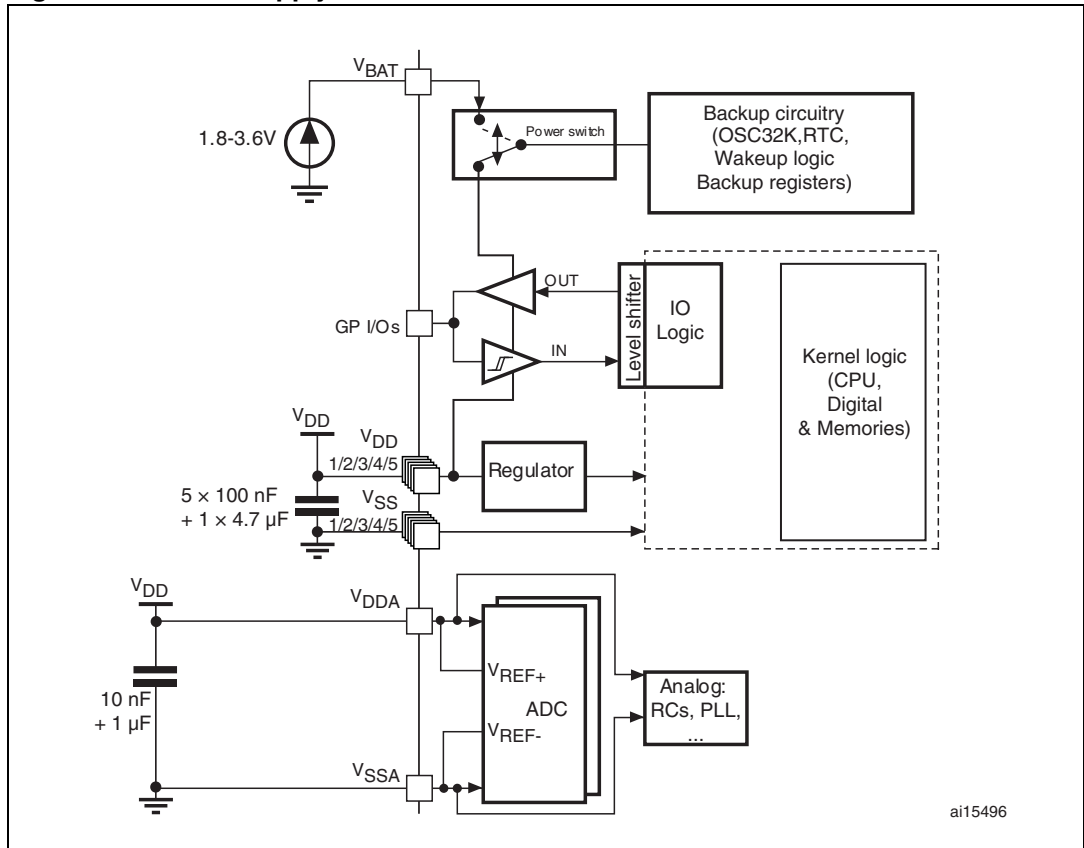

Figure 9. Pin input voltage



### 5.1.6 Power supply scheme

Figure 10. Power supply scheme



**Caution:** In [Figure 10](#), the 4.7 μF capacitor must be connected to V<sub>DD3</sub>.

### 5.1.7 Current consumption measurement

Figure 11. Current consumption measurement scheme

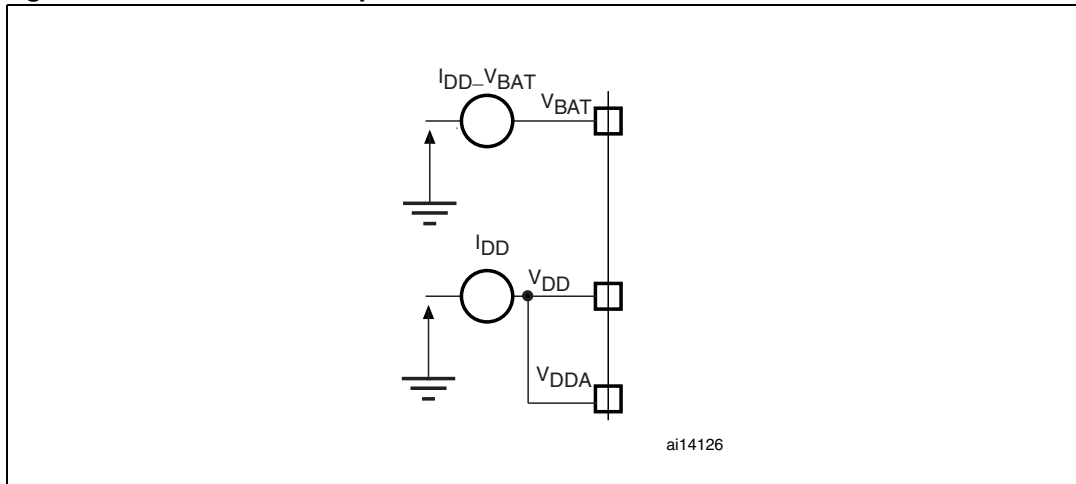

## 5.2 Absolute maximum ratings

Stresses above the absolute maximum ratings listed in [Table 5: Voltage characteristics](#), [Table 6: Current characteristics](#), and [Table 7: Thermal characteristics](#) may cause permanent damage to the device. These are stress ratings only and functional operation of the device at these conditions is not implied. Exposure to maximum rating conditions for extended periods may affect device reliability.

Table 5. Voltage characteristics

Symbol	Ratings	Min	Max	Unit
$V_{DD} - V_{SS}$	External main supply voltage (including $V_{DDA}$ and $V_{DD}$ ) <sup>(1)</sup>	-0.3	4.0	V
$V_{IN}$	Input voltage on five volt tolerant pin <sup>(2)</sup>	$V_{SS} - 0.3$	+5.5	
	Input voltage on any other pin <sup>(2)</sup>	$V_{SS} - 0.3$	$V_{DD} + 0.3$	
$ \Delta V_{DDx} $	Variations between different $V_{DD}$ power pins		50	mV
$ V_{SSx} - V_{SS} $	Variations between all the different ground pins		50	
$V_{ESD(HBM)}$	Electrostatic discharge voltage (human body model)	see <a href="#">Section 5.3.11: Absolute maximum ratings (electrical sensitivity)</a>		

- All main power ( $V_{DD}$ ,  $V_{DDA}$ ) and ground ( $V_{SS}$ ,  $V_{SSA}$ ) pins must always be connected to the external power supply, in the permitted range.
- $I_{INJ(PIN)}$  must never be exceeded (see [Table 6: Current characteristics](#)). This is implicitly insured if  $V_{IN}$  maximum is respected. If  $V_{IN}$  maximum cannot be respected, the injection current must be limited externally to the  $I_{INJ(PIN)}$  value. A positive injection is induced by  $V_{IN} > V_{INmax}$  while a negative injection is induced by  $V_{IN} < V_{SS}$ .

**Table 6. Current characteristics**

Symbol	Ratings	Max.	Unit
$I_{VDD}$	Total current into $V_{DD}/V_{DDA}$ power lines (source) <sup>(1)</sup>	150	mA
$I_{VSS}$	Total current out of $V_{SS}$ ground lines (sink) <sup>(1)</sup>	150	
$I_{IO}$	Output current sunk by any I/O and control pin	25	
	Output current source by any I/Os and control pin	- 25	
$I_{INJ(PIN)}$ <sup>(2)(3)</sup>	Injected current on NRST pin	± 5	
	Injected current on High-speed external OSC_IN and Low-speed external OSC_IN pins	± 5	
	Injected current on any other pin <sup>(4)</sup>	± 5	
$\Sigma I_{INJ(PIN)}$ <sup>(2)</sup>	Total injected current (sum of all I/O and control pins) <sup>(4)</sup>	± 25	

1. All main power ( $V_{DD}$ ,  $V_{DDA}$ ) and ground ( $V_{SS}$ ,  $V_{SSA}$ ) pins must always be connected to the external power supply, in the permitted range.
2.  $I_{INJ(PIN)}$  must never be exceeded. This is implicitly insured if  $V_{IN}$  maximum is respected. If  $V_{IN}$  maximum cannot be respected, the injection current must be limited externally to the  $I_{INJ(PIN)}$  value. A positive injection is induced by  $V_{IN} > V_{DD}$  while a negative injection is induced by  $V_{IN} < V_{SS}$ .
3. Negative injection disturbs the analog performance of the device. See note in [Section 5.3.16: 12-bit ADC characteristics](#).
4. When several inputs are submitted to a current injection, the maximum  $\Sigma I_{INJ(PIN)}$  is the absolute sum of the positive and negative injected currents (instantaneous values). These results are based on characterization with  $\Sigma I_{INJ(PIN)}$  maximum current injection on four I/O port pins of the device.

**Table 7. Thermal characteristics**

Symbol	Ratings	Value	Unit
$T_{STG}$	Storage temperature range	-65 to +150	°C
$T_J$	Maximum junction temperature	150	°C

## 5.3 Operating conditions

### 5.3.1 General operating conditions

**Table 8. General operating conditions**

Symbol	Parameter	Conditions	Min	Max	Unit
$f_{HCLK}$	Internal AHB clock frequency		0	36	MHz
$f_{PCLK1}$	Internal APB1 clock frequency		0	36	
$f_{PCLK2}$	Internal APB2 clock frequency		0	36	
$V_{DD}$	Standard operating voltage		2	3.6	V
$V_{DDA}$ <sup>(1)</sup>	Analog operating voltage (ADC not used)	Must be the same potential as $V_{DD}$ <sup>(2)</sup>	2	3.6	V
	Analog operating voltage (ADC used)		2.4	3.6	
$V_{BAT}$	Backup operating voltage		1.8	3.6	V

**Table 8. General operating conditions (continued)**

Symbol	Parameter	Conditions	Min	Max	Unit
$P_D$	Power dissipation at $T_A = 85\text{ °C}^{(3)}$	LQFP64		444	mW
		LQFP48		363	
		VFQFPN36		1110	
$T_A$	Ambient temperature	Maximum power dissipation	-40	85	°C
		Low power dissipation <sup>(4)</sup>	-40	105	°C
$T_J$	Junction temperature range		-40	105	°C

1. When the ADC is used, refer to [Table 41: ADC characteristics](#).
2. It is recommended to power  $V_{DD}$  and  $V_{DDA}$  from the same source. A maximum difference of 300 mV between  $V_{DD}$  and  $V_{DDA}$  can be tolerated during power-up and operation.
3. If  $T_A$  is lower, higher  $P_D$  values are allowed as long as  $T_J$  does not exceed  $T_{Jmax}$  (see [Table 6.2: Thermal characteristics on page 73](#)).
4. In low power dissipation state,  $T_A$  can be extended to this range as long as  $T_J$  does not exceed  $T_{Jmax}$  (see [Table 6.2: Thermal characteristics on page 73](#)).

### 5.3.2 Operating conditions at power-up / power-down

Subject to general operating conditions for  $T_A$ .

**Table 9. Operating conditions at power-up / power-down**

Symbol	Parameter	Conditions	Min	Max	Unit
$t_{VDD}$	$V_{DD}$ rise time rate		0	$\infty$	$\mu\text{s/V}$
	$V_{DD}$ fall time rate		20	$\infty$	

### 5.3.3 Embedded reset and power control block characteristics

The parameters given in [Table 10](#) are derived from tests performed under the ambient temperature and  $V_{DD}$  supply voltage conditions summarized in [Table 8](#).

Table 10. Embedded reset and power control block characteristics

Symbol	Parameter	Conditions	Min	Typ	Max	Unit
$V_{PVD}$	Programmable voltage detector level selection	PLS[2:0]=000 (rising edge)	2.1	2.18	2.26	V
		PLS[2:0]=000 (falling edge)	2	2.08	2.16	V
		PLS[2:0]=001 (rising edge)	2.19	2.28	2.37	V
		PLS[2:0]=001 (falling edge)	2.09	2.18	2.27	V
		PLS[2:0]=010 (rising edge)	2.28	2.38	2.48	V
		PLS[2:0]=010 (falling edge)	2.18	2.28	2.38	V
		PLS[2:0]=011 (rising edge)	2.38	2.48	2.58	V
		PLS[2:0]=011 (falling edge)	2.28	2.38	2.48	V
		PLS[2:0]=100 (rising edge)	2.47	2.58	2.69	V
		PLS[2:0]=100 (falling edge)	2.37	2.48	2.59	V
		PLS[2:0]=101 (rising edge)	2.57	2.68	2.79	V
		PLS[2:0]=101 (falling edge)	2.47	2.58	2.69	V
		PLS[2:0]=110 (rising edge)	2.66	2.78	2.9	V
		PLS[2:0]=110 (falling edge)	2.56	2.68	2.8	V
		PLS[2:0]=111 (rising edge)	2.76	2.88	3	V
		PLS[2:0]=111 (falling edge)	2.66	2.78	2.9	V
$V_{PVDhyst}^{(2)}$	PVD hysteresis			100		mV
$V_{POR/PDR}$	Power on/power down reset threshold	Falling edge	1.8 <sup>(1)</sup>	1.88	1.96	V
		Rising edge	1.84	1.92	2.0	V
$V_{PDRhyst}^{(2)}$	PDR hysteresis			40		mV
$t_{RSTTEMPO}^{(2)}$	Reset temporization		1.5	2.5	4.5	ms

1. The product behavior is guaranteed by design down to the minimum  $V_{POR/PDR}$  value.

2. Guaranteed by design, not tested in production.

### 5.3.4 Embedded reference voltage

The parameters given in [Table 11](#) are derived from tests performed under the ambient temperature and  $V_{DD}$  supply voltage conditions summarized in [Table 8](#).

**Table 11. Embedded internal reference voltage**

Symbol	Parameter	Conditions	Min	Typ	Max	Unit
$V_{REFINT}$	Internal reference voltage	$-40\text{ }^{\circ}\text{C} < T_A < +85\text{ }^{\circ}\text{C}$	1.16	1.20	1.24	V
$T_{S\_vrefint}^{(1)}$	ADC sampling time when reading the internal reference voltage			5.1	17.1 <sup>(2)</sup>	$\mu\text{s}$
$V_{RERINT}^{(2)}$	Internal reference voltage spread over the temperature range	$V_{DD} = 3\text{ V} \pm 10\text{ mV}$			10	mV
$T_{Coeff}^{(2)}$	Temperature coefficient				100	ppm/ $^{\circ}\text{C}$

1. Shortest sampling time can be determined in the application by multiple iterations.
2. Guaranteed by design, not tested in production.

### 5.3.5 Supply current characteristics

The current consumption is a function of several parameters and factors such as the operating voltage, ambient temperature, I/O pin loading, device software configuration, operating frequencies, I/O pin switching rate, program location in memory and executed binary code.

The current consumption is measured as described in [Figure 11: Current consumption measurement scheme](#).

All Run-mode current consumption measurements given in this section are performed with a reduced code that gives a consumption equivalent to Dhrystone 2.1 code.

#### Maximum current consumption

The MCU is placed under the following conditions:

- All I/O pins are in input mode with a static value at  $V_{DD}$  or  $V_{SS}$  (no load)
- All peripherals are disabled except if it is explicitly mentioned
- The Flash access time is adjusted to  $f_{HCLK}$  frequency (0 wait state from 0 to 24 MHz, 1 wait state from 24 to 36 MHz)
- Prefetch in on (reminder: this bit must be set before clock setting and bus prescaling)
- When the peripherals are enabled  $f_{PCLK1} = f_{HCLK}/2$ ,  $f_{PCLK2} = f_{HCLK}$

The parameters given in [Table 12](#) are derived from tests performed under the ambient temperature and  $V_{DD}$  supply voltage conditions summarized in [Table 8](#).

**Table 12. Maximum current consumption in Run mode, code with data processing running from Flash**

Symbol	Parameter	Conditions	f <sub>HCLK</sub>	Max <sup>(1)</sup>	Unit
				T <sub>A</sub> = 85 °C	
I <sub>DD</sub>	Supply current in Run mode	External clock <sup>(2)</sup> , all peripherals enabled	36 MHz	26	mA
			24 MHz	18	
			16 MHz	13	
			8 MHz	7	
		External clock <sup>(2)</sup> , all peripherals Disabled	36 MHz	19	
			24 MHz	13	
			16 MHz	10	
			8 MHz	6	

1. Based on characterization, not tested in production.
2. External clock is 8 MHz and PLL is on when f<sub>HCLK</sub> > 8 MHz.

**Table 13. Maximum current consumption in Run mode, code with data processing running from RAM**

Symbol	Parameter	Conditions	f <sub>HCLK</sub>	Max <sup>(1)</sup>	Unit
				T <sub>A</sub> = 85 °C	
I <sub>DD</sub>	Supply current in Run mode	External clock <sup>(2)</sup> , all peripherals enabled	36 MHz	20	mA
			24 MHz	14	
			16 MHz	10	
			8 MHz	6	
		External clock <sup>(2)</sup> all peripherals disabled	36 MHz	15	
			24 MHz	10	
			16 MHz	7	
			8 MHz	5	

1. Based on characterization, tested in production at V<sub>DD</sub> max, f<sub>HCLK</sub> max.
2. External clock is 8 MHz and PLL is on when f<sub>HCLK</sub> > 8 MHz.

**Figure 12. Typical current consumption in Run mode versus frequency (at 3.6 V) - code with data processing running from RAM, peripherals enabled**

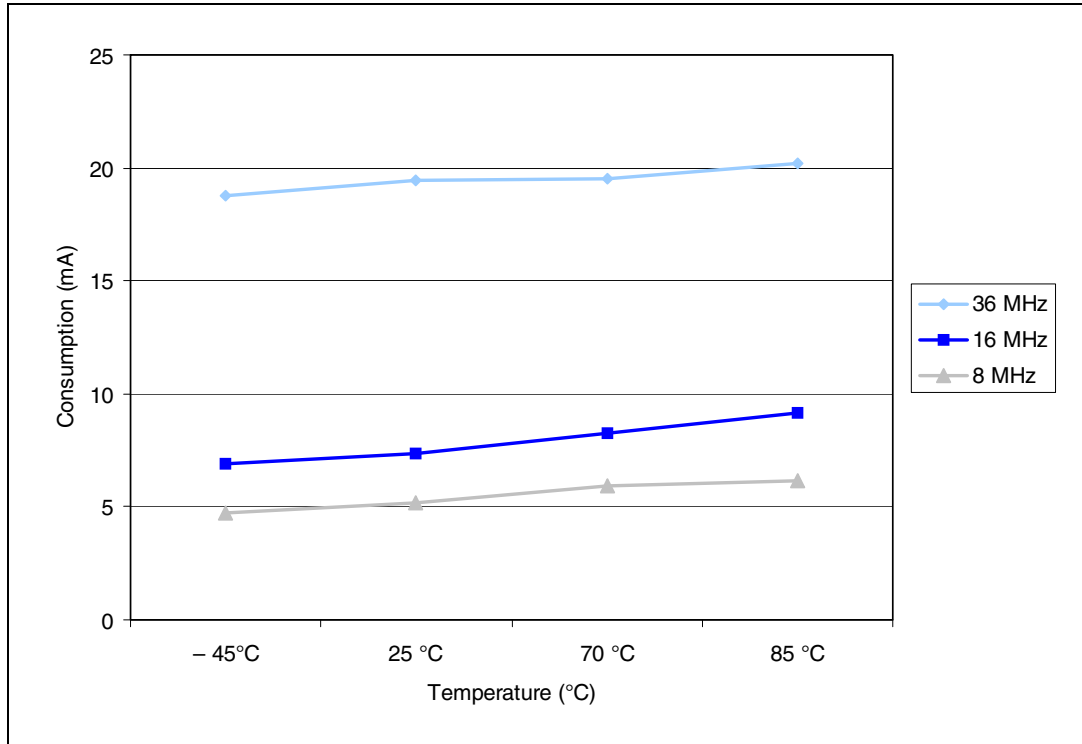

**Figure 13. Typical current consumption in Run mode versus frequency (at 3.6 V) - code with data processing running from RAM, peripherals disabled**

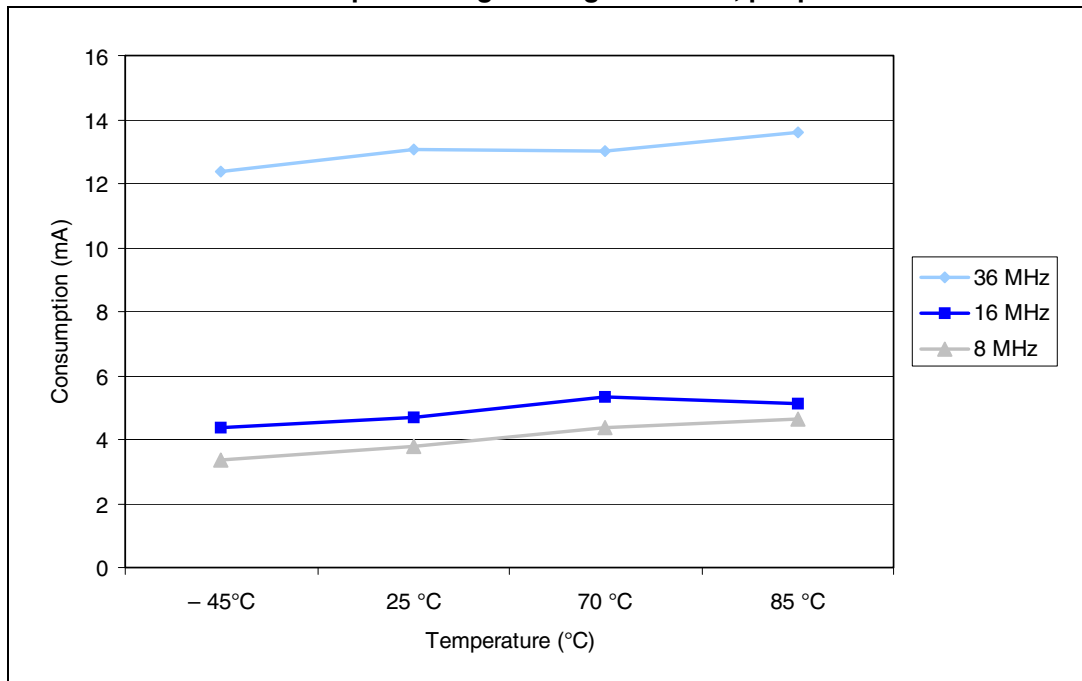

**Table 14. Maximum current consumption in Sleep mode, code running from Flash or RAM**

Symbol	Parameter	Conditions	f <sub>HCLK</sub>	Max <sup>(1)</sup>	Unit
				T <sub>A</sub> = 85 °C	
I <sub>DD</sub>	Supply current in Sleep mode	External clock <sup>(2)</sup> all peripherals enabled	36 MHz	14	mA
			24 MHz	10	
			16 MHz	7	
			8 MHz	4	
		External clock <sup>(2)</sup> , all peripherals disabled	36 MHz	5	
			24 MHz	4.5	
			16 MHz	4	
			8 MHz	3	

1. Based on characterization, tested in production at V<sub>DD</sub> max and f<sub>HCLK</sub> max with peripherals enabled.
2. External clock is 8 MHz and PLL is on when f<sub>HCLK</sub> > 8 MHz.

**Table 15. Typical and maximum current consumptions in Stop and Standby modes**

Symbol	Parameter	Conditions	Typ <sup>(1)</sup>			Max	Unit
			V <sub>DD</sub> /V <sub>BAT</sub> = 2.0 V	V <sub>DD</sub> /V <sub>BAT</sub> = 2.4 V	V <sub>DD</sub> /V <sub>BAT</sub> = 3.3 V	T <sub>A</sub> = 85 °C <sup>(2)</sup>	
I <sub>DD</sub>	Supply current in Stop mode	Regulator in Run mode, Low-speed and high-speed internal RC oscillators and high-speed oscillator OFF (no independent watchdog)	-	21.3	21.7	160	µA
		Regulator in Low Power mode, Low-speed and high-speed internal RC oscillators and high-speed oscillator OFF (no independent watchdog)	-	11.3	11.7	145	
	Supply current in Standby mode	Low-speed internal RC oscillator and independent watchdog ON	-	2.6	3.4	-	
		Low-speed internal RC oscillator ON, independent watchdog OFF	-	2.4	3.2	-	
		Low-speed internal RC oscillator and independent watchdog OFF, low-speed oscillator and RTC OFF	-	1.7	2	3.2	
I <sub>DD_VBAT</sub>	Backup domain supply current	Low-speed oscillator and RTC ON	0.9	1.1	1.4	1.9	

1. Typical values are measured at T<sub>A</sub> = 25 °C.
2. Based on characterization, not rested in production.

Figure 14. Typical current consumption on  $V_{BAT}$  with RTC on versus temperature at different  $V_{BAT}$  values

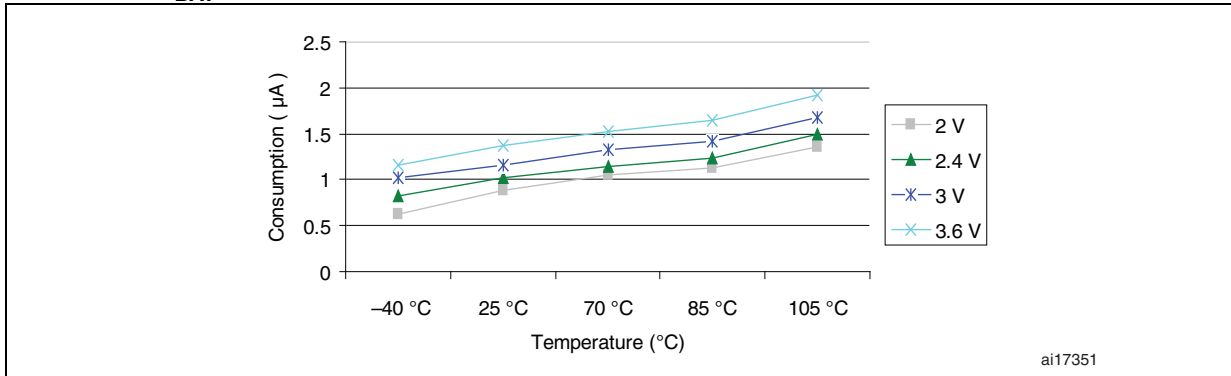

Figure 15. Typical current consumption in Stop mode with regulator in Run mode versus temperature at  $V_{DD} = 3.3 V$  and  $3.6 V$

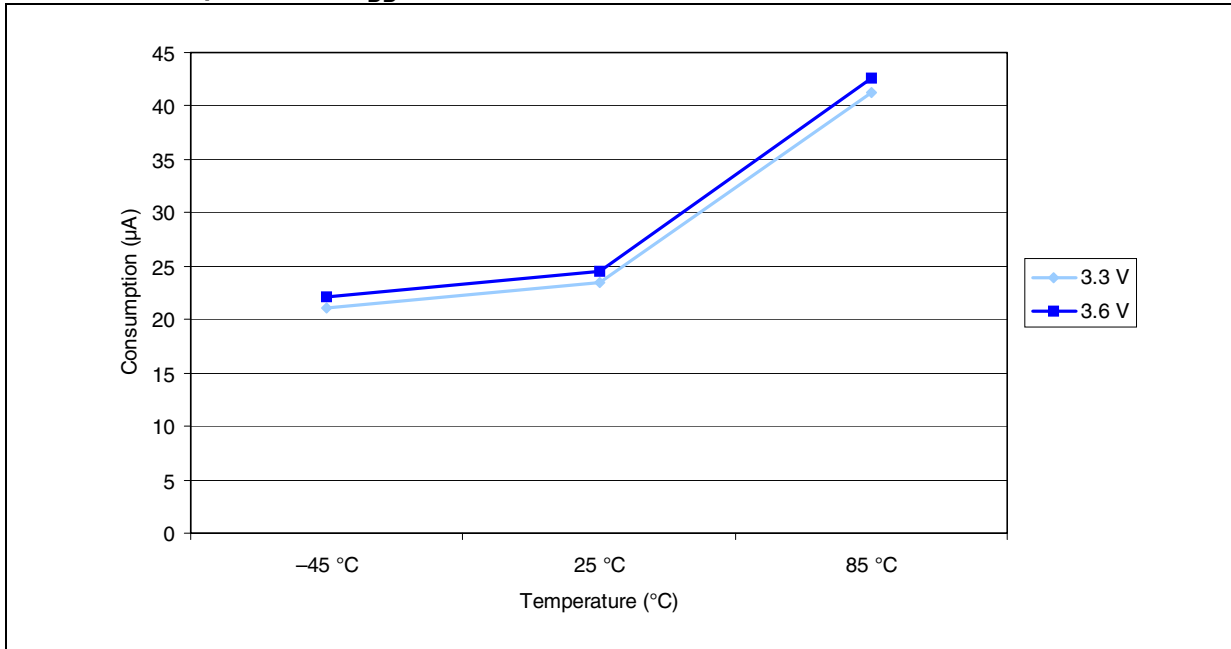

Figure 16. Typical current consumption in Stop mode with regulator in Low-power mode versus temperature at  $V_{DD} = 3.3\text{ V}$  and  $3.6\text{ V}$

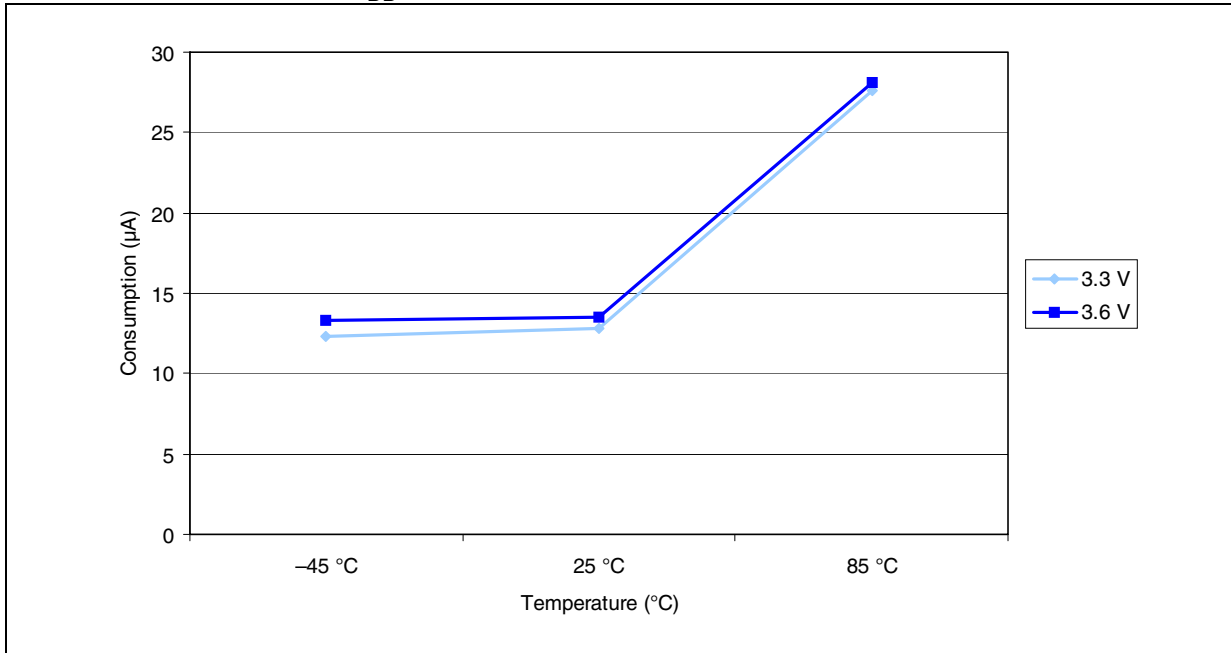
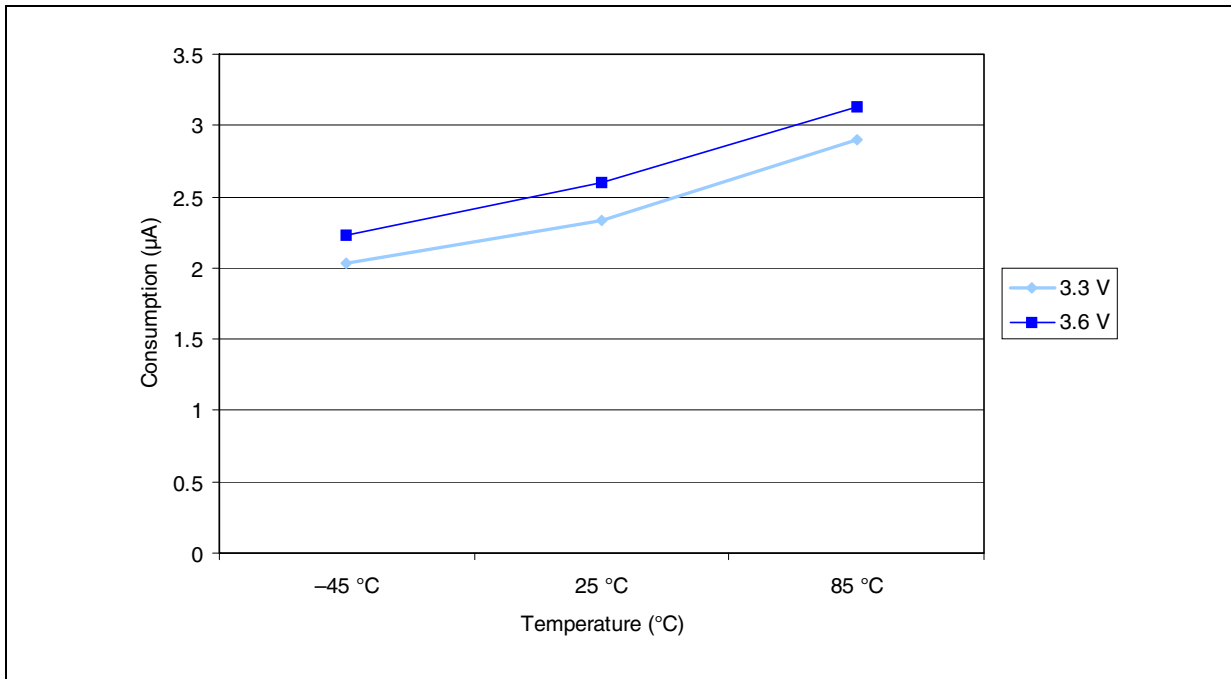

Figure 17. Typical current consumption in Standby mode versus temperature at  $V_{DD} = 3.3\text{ V}$  and  $3.6\text{ V}$



**Typical current consumption**

The MCU is placed under the following conditions:

- All I/O pins are in input mode with a static value at V<sub>DD</sub> or V<sub>SS</sub> (no load)
- All peripherals are disabled except if it is explicitly mentioned
- The Flash access time is adjusted to f<sub>HCLK</sub> frequency (0 wait state from 0 to 24 MHz, 1 wait state from 24 to 36 MHz)
- Prefetch is on (reminder: this bit must be set before clock setting and bus prescaling)
- When the peripherals are enabled f<sub>PCLK1</sub> = f<sub>HCLK</sub>/4, f<sub>PCLK2</sub> = f<sub>HCLK</sub>/2, f<sub>ADCCLK</sub> = f<sub>PCLK2</sub>/4

The parameters given in [Table 16](#) are derived from tests performed under the ambient temperature and V<sub>DD</sub> supply voltage conditions summarized in [Table 8](#).

**Table 16. Typical current consumption in Run mode, code with data processing running from Flash**

Symbol	Parameter	Conditions	f <sub>HCLK</sub>	Typ <sup>(1)</sup>		Unit
				All peripherals enabled <sup>(2)</sup>	All peripherals disabled	
I <sub>DD</sub>	Supply current in Run mode	External clock <sup>(3)</sup>	36 MHz	17.2	13.8	mA
			24 MHz	11.2	8.9	
			16 MHz	8.1	6.6	
			8 MHz	5	4.2	
			4 MHz	3	2.6	
			2 MHz	2	1.8	
			1 MHz	1.5	1.4	
			500 kHz	1.2	1.2	
		125 kHz	1.05	1		
		Running on high speed internal RC (HSI), AHB prescaler used to reduce the frequency	36 MHz	16.5	13.1	
			24 MHz	10.5	8.2	
			16 MHz	7.4	5.9	
			8 MHz	4.3	3.6	
			4 MHz	2.4	2	
			2 MHz	1.5	1.3	
			1 MHz	1	0.9	
500 kHz	0.7		0.65			
125 kHz	0.5	0.45				

1. Typical values are measures at T<sub>A</sub> = 25 °C, V<sub>DD</sub> = 3.3 V.
2. Add an additional power consumption of 0.8 mA per ADC for the analog part. In applications, this consumption occurs only while the ADC is on (ADON bit is set in the ADC\_CR2 register).
3. External clock is 8 MHz and PLL is on when f<sub>HCLK</sub> > 8 MHz.

**Table 17. Typical current consumption in Sleep mode, code running from Flash or RAM**

Symbol	Parameter	Conditions	f <sub>HCLK</sub>	Typ <sup>(1)</sup>		Unit
				All peripherals enabled <sup>(2)</sup>	All peripherals disabled	
I <sub>DD</sub>	Supply current in Sleep mode	External clock <sup>(3)</sup>	36 MHz	6.7	3.1	mA
			24 MHz	4.8	2.3	
			16 MHz	3.4	1.8	
			8 MHz	2	1.2	
			4 MHz	1.5	1.1	
			2 MHz	1.25	1	
			1 MHz	1.1	0.98	
			500 kHz	1.05	0.96	
			125 kHz	1	0.95	
		Running on High Speed Internal RC (HSI), AHB prescaler used to reduce the frequency	36 MHz	6.1	2.5	
			24 MHz	4.2	1.7	
			16 MHz	2.8	1.2	
			8 MHz	1.4	0.55	
			4 MHz	0.9	0.5	
			2 MHz	0.7	0.45	
			1 MHz	0.55	0.42	
			500 kHz	0.48	0.4	
			125 kHz	0.4	0.38	

1. Typical values are measures at T<sub>A</sub> = 25 °C, V<sub>DD</sub> = 3.3 V.
2. Add an additional power consumption of 0.8 mA per ADC for the analog part. In applications, this consumption occurs only while the ADC is on (ADON bit is set in the ADC\_CR2 register).
3. External clock is 8 MHz and PLL is on when f<sub>HCLK</sub> > 8 MHz.

**On-chip peripheral current consumption**

The current consumption of the on-chip peripherals is given in [Table 18](#). The MCU is placed under the following conditions:

- all I/O pins are in input mode with a static value at  $V_{DD}$  or  $V_{SS}$  (no load)
- all peripherals are disabled unless otherwise mentioned
- the given value is calculated by measuring the current consumption
  - with all peripherals clocked off
  - with only one peripheral clocked on
- ambient operating temperature and  $V_{DD}$  supply voltage conditions summarized in [Table 5](#).

**Table 18. Peripheral current consumption**

Peripheral		Typical consumption at 25 °C	Unit
APB1	TIM2	0.6	mA
	TIM3	0.6	
	USART2	0.21	
	I2C	0.18	
APB2	GPIO A	0.21	
	GPIO B	0.21	
	GPIO C	0.21	
	GPIO D	0.21	
	ADC <sup>(1)</sup>	1.4	
	SPI	0.24	
	USART1	0.35	

1. Specific conditions for ADC:  $f_{HCLK} = 28$  MHz,  $f_{APB1} = f_{HCLK}/2$ ,  $f_{APB2} = f_{HCLK}$ ,  $f_{ADCCLK} = f_{APB2}/2$ , ADON bit in the ADC\_CR2 register is set to 1.

**5.3.6 External clock source characteristics**

**High-speed external user clock generated from an external source**

The characteristics given in [Table 19](#) result from tests performed using an high-speed external clock source, and under the ambient temperature and supply voltage conditions summarized in [Table 8](#).

**Table 19. High-speed external user clock characteristics**

Symbol	Parameter	Conditions	Min	Typ	Max	Unit
$f_{\text{HSE\_ext}}$	User external clock source frequency <sup>(1)</sup>		1	8	25	MHz
$V_{\text{HSEH}}$	OSC_IN input pin high level voltage		$0.7V_{\text{DD}}$		$V_{\text{DD}}$	V
$V_{\text{HSEL}}$	OSC_IN input pin low level voltage		$V_{\text{SS}}$		$0.3V_{\text{DD}}$	
$t_{\text{w(HSE)}}$ $t_{\text{w(HSE)}}$	OSC_IN high or low time <sup>(1)</sup>		16			ns
$t_{\text{r(HSE)}}$ $t_{\text{f(HSE)}}$	OSC_IN rise or fall time <sup>(1)</sup>				20	
$C_{\text{in(HSE)}}$	OSC_IN input capacitance <sup>(1)</sup>			5		pF
$\text{DuCy}_{\text{(HSE)}}$	Duty cycle		45		55	%
$I_{\text{L}}$	OSC_IN Input leakage current	$V_{\text{SS}} \leq V_{\text{IN}} \leq V_{\text{DD}}$			$\pm 1$	$\mu\text{A}$

1. Guaranteed by design, not tested in production.

### Low-speed external user clock generated from an external source

The characteristics given in [Table 20](#) result from tests performed using an low-speed external clock source, and under the ambient temperature and supply voltage conditions summarized in [Table 8](#).

**Table 20. Low-speed external user clock characteristics**

Symbol	Parameter	Conditions	Min	Typ	Max	Unit
$f_{\text{LSE\_ext}}$	User external clock source frequency <sup>(1)</sup>			32.768	1000	kHz
$V_{\text{LSEH}}$	OSC32_IN input pin high level voltage		$0.7V_{\text{DD}}$		$V_{\text{DD}}$	V
$V_{\text{LSEL}}$	OSC32_IN input pin low level voltage		$V_{\text{SS}}$		$0.3V_{\text{DD}}$	
$t_{\text{w(LSE)}}$ $t_{\text{w(LSE)}}$	OSC32_IN high or low time <sup>(1)</sup>		450			ns
$t_{\text{r(LSE)}}$ $t_{\text{f(LSE)}}$	OSC32_IN rise or fall time <sup>(1)</sup>				50	
$C_{\text{in(LSE)}}$	OSC32_IN input capacitance <sup>(1)</sup>			5		pF
$\text{DuCy}_{\text{(LSE)}}$	Duty cycle		30		70	%
$I_{\text{L}}$	OSC32_IN Input leakage current	$V_{\text{SS}} \leq V_{\text{IN}} \leq V_{\text{DD}}$			$\pm 1$	$\mu\text{A}$

1. Guaranteed by design, not tested in production.

**Figure 18. High-speed external clock source AC timing diagram**

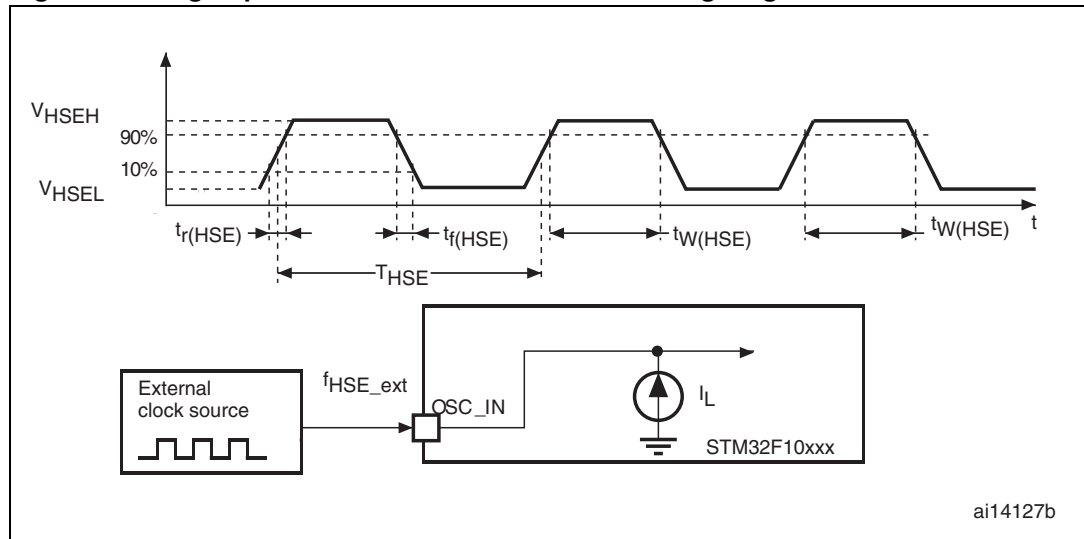

ai14127b

**Figure 19. Low-speed external clock source AC timing diagram**

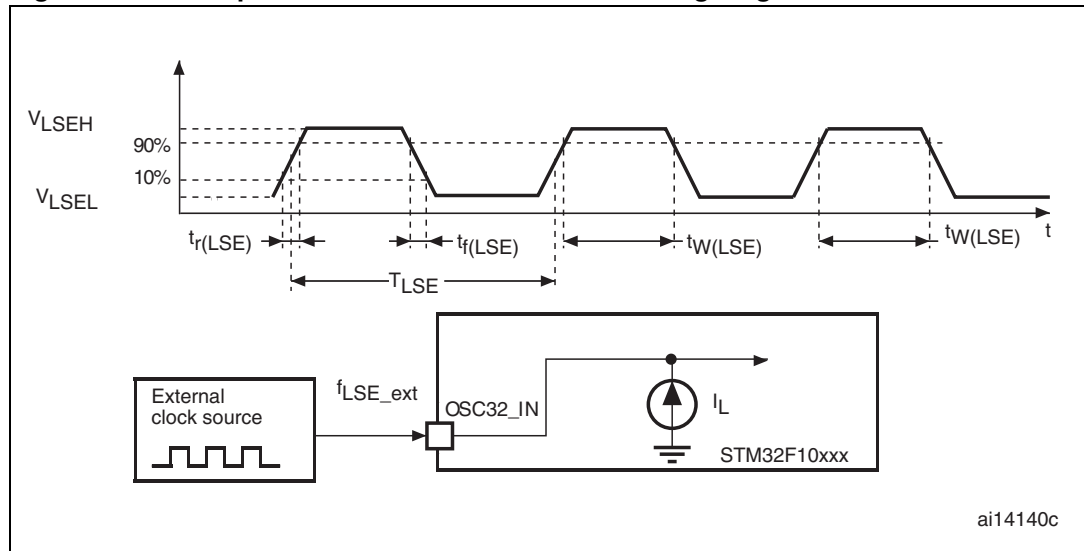

ai14140c

**High-speed external clock generated from a crystal/ceramic resonator**

The high-speed external (HSE) clock can be supplied with a 4 to 16 MHz crystal/ceramic resonator oscillator. All the information given in this paragraph are based on characterization results obtained with typical external components specified in [Table 21](#). In the application, the resonator and the load capacitors have to be placed as close as possible to the oscillator pins in order to minimize output distortion and startup stabilization time. Refer to the crystal resonator manufacturer for more details on the resonator characteristics (frequency, package, accuracy).

**Table 21. HSE 4-16 MHz oscillator characteristics<sup>(1)(2)</sup>**

Symbol	Parameter	Conditions	Min	Typ	Max	Unit
$f_{OSC\_IN}$	Oscillator frequency		4	8	16	MHz
$R_F$	Feedback resistor			200		k $\Omega$
C	Recommended load capacitance versus equivalent serial resistance of the crystal ( $R_S$ ) <sup>(3)</sup>	$R_S = 30 \Omega$		30		pF
$i_2$	HSE driving current	$V_{DD} = 3.3 V, V_{IN} = V_{SS}$ with 30 pF load			1	mA
$g_m$	Oscillator transconductance	Startup	25			mA/V
$t_{SU(HSE)}$ <sup>(4)</sup>	Startup time	$V_{DD}$ is stabilized		2		ms

1. Resonator characteristics given by the crystal/ceramic resonator manufacturer.
2. Based on characterization, not tested in production.
3. The relatively low value of the RF resistor offers a good protection against issues resulting from use in a humid environment, due to the induced leakage and the bias condition change. However, it is recommended to take this point into account if the MCU is used in tough humidity conditions.
4.  $t_{SU(HSE)}$  is the startup time measured from the moment it is enabled (by software) to a stabilized 8 MHz oscillation is reached. This value is measured for a standard crystal resonator and it can vary significantly with the crystal manufacturer

For  $C_{L1}$  and  $C_{L2}$ , it is recommended to use high-quality external ceramic capacitors in the 5 pF to 25 pF range (typ.), designed for high-frequency applications, and selected to match the requirements of the crystal or resonator (see [Figure 20](#)).  $C_{L1}$  and  $C_{L2}$  are usually the same size. The crystal manufacturer typically specifies a load capacitance which is the series combination of  $C_{L1}$  and  $C_{L2}$ . PCB and MCU pin capacitance must be included (10 pF can be used as a rough estimate of the combined pin and board capacitance) when sizing  $C_{L1}$  and  $C_{L2}$ . Refer to the application note AN2867 “Oscillator design guide for ST microcontrollers” available from the ST website [www.st.com](http://www.st.com).

**Figure 20. Typical application with an 8 MHz crystal**

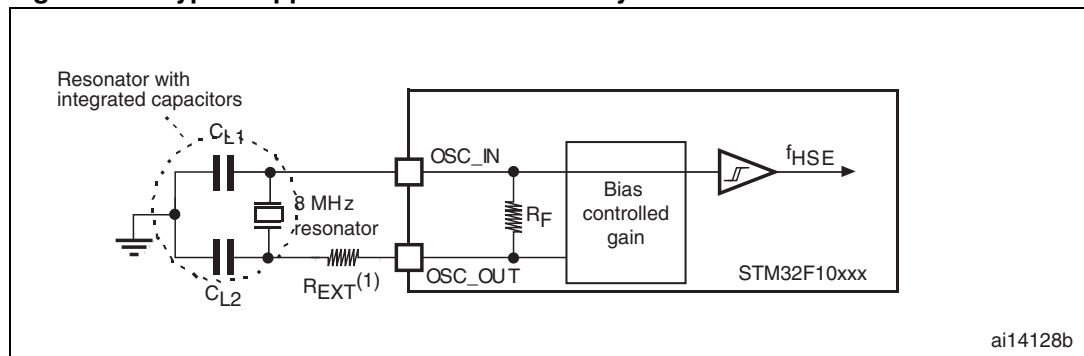

1.  $R_{EXT}$  value depends on the crystal characteristics.

**Low-speed external clock generated from a crystal/ceramic resonator**

The low-speed external (LSE) clock can be supplied with a 32.768 kHz crystal/ceramic resonator oscillator. All the information given in this paragraph are based on characterization results obtained with typical external components specified in [Table 22](#). In the application, the resonator and the load capacitors have to be placed as close as possible to the oscillator pins in order to minimize output distortion and startup stabilization time. Refer to the crystal

resonator manufacturer for more details on the resonator characteristics (frequency, package, accuracy).

**Table 22. LSE oscillator characteristics ( $f_{LSE} = 32.768 \text{ kHz}$ )<sup>(1)</sup>**

Symbol	Parameter	Conditions	Min	Typ	Max	Unit
$R_F$	Feedback resistor			5		$M\Omega$
$C^{(2)}$	Recommended load capacitance versus equivalent serial resistance of the crystal ( $R_S$ ) <sup>(3)</sup>	$R_S = 30 \text{ K}\Omega$			15	$\mu\text{F}$
$I_2$	LSE driving current	$V_{DD} = 3.3 \text{ V}$ $V_{IN} = V_{SS}$			1.4	$\mu\text{A}$
$g_m$	Oscillator transconductance		5			$\mu\text{A/V}$
$t_{SU(LSE)}^{(4)}$	Startup time	$V_{DD}$ is stabilized		3		s

1. Based on characterization, not tested in production.
2. Refer to the note and caution paragraphs below the table, and to the application note AN2867 "Oscillator design guide for ST microcontrollers".
3. The oscillator selection can be optimized in terms of supply current using an high quality resonator with small  $R_S$  value for example MSIV-TIN32.768 kHz. Refer to crystal manufacturer for more details
4.  $t_{SU(LSE)}$  is the startup time measured from the moment it is enabled (by software) to a stabilized 32.768 kHz oscillation is reached. This value is measured for a standard crystal resonator and it can vary significantly with the crystal manufacturer

**Note:** For  $C_{L1}$  and  $C_{L2}$  it is recommended to use high-quality ceramic capacitors in the 5 pF to 15 pF range selected to match the requirements of the crystal or resonator.  $C_{L1}$  and  $C_{L2}$ , are usually the same size. The crystal manufacturer typically specifies a load capacitance which is the series combination of  $C_{L1}$  and  $C_{L2}$ . Load capacitance  $C_L$  has the following formula:  $C_L = C_{L1} \times C_{L2} / (C_{L1} + C_{L2}) + C_{stray}$  where  $C_{stray}$  is the pin capacitance and board or trace PCB-related capacitance. Typically, it is between 2 pF and 7 pF.

**Caution:** To avoid exceeding the maximum value of  $C_{L1}$  and  $C_{L2}$  (15 pF) it is strongly recommended to use a resonator with a load capacitance  $C_L \leq 7 \text{ pF}$ . Never use a resonator with a load capacitance of 12.5 pF.

**Example:** if you choose a resonator with a load capacitance of  $C_L = 6 \text{ pF}$ , and  $C_{stray} = 2 \text{ pF}$ , then  $C_{L1} = C_{L2} = 8 \text{ pF}$ .

**Figure 21. Typical application with a 32.768 kHz crystal**

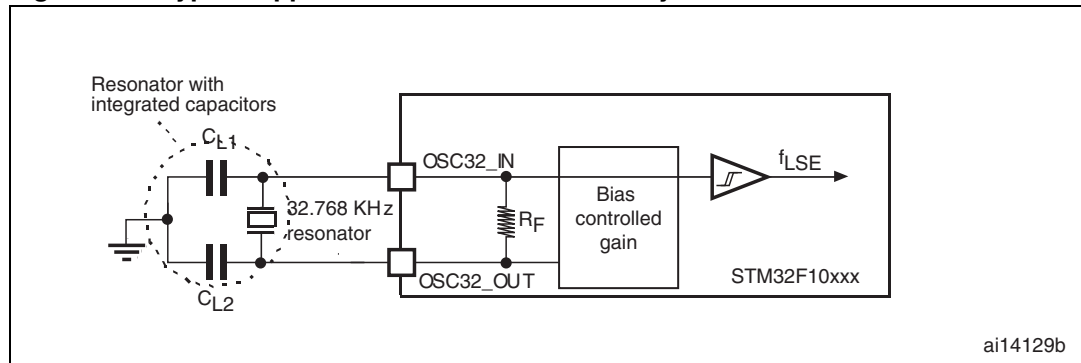

ai14129b

### 5.3.7 Internal clock source characteristics

The parameters given in [Table 23](#) are derived from tests performed under the ambient temperature and  $V_{DD}$  supply voltage conditions summarized in [Table 8](#).

#### High-speed internal (HSI) RC oscillator

**Table 23. HSI oscillator characteristics<sup>(1)</sup>**

Symbol	Parameter	Conditions	Min	Typ	Max	Unit	
$f_{HSI}$	Frequency			8		MHz	
$ACC_{HSI}$	Accuracy of the HSI oscillator	User-trimmed with the RCC_CR register <sup>(2)</sup>			1 <sup>(3)</sup>	%	
		Factory-calibrated <sup>(4)</sup>	$T_A = -40$ to $105$ °C	-2		2.5	%
			$T_A = -10$ to $85$ °C	-1.5		2.2	%
			$T_A = 0$ to $70$ °C	-1.3		2	%
	$T_A = 25$ °C	-1.1		1.8	%		
$t_{su(HSI)}$ <sup>(4)</sup>	HSI oscillator startup time		1		2	μs	
$I_{DD(HSI)}$ <sup>(4)</sup>	HSI oscillator power consumption			80	100	μA	

- $V_{DD} = 3.3$  V,  $T_A = -40$  to  $105$  °C unless otherwise specified.
- Refer to application note AN2868 “STM32F10xxx internal RC oscillator (HSI) calibration” available from the ST website [www.st.com](http://www.st.com).
- Guaranteed by design, not tested in production.
- Based on characterization, not tested in production.

#### Low-speed internal (LSI) RC oscillator

**Table 24. LSI oscillator characteristics<sup>(1)</sup>**

Symbol	Parameter	Min	Typ	Max	Unit
$f_{LSI}$ <sup>(2)</sup>	Frequency	30	40	60	kHz
$t_{su(LSI)}$ <sup>(3)</sup>	LSI oscillator startup time			85	μs
$I_{DD(LSI)}$ <sup>(3)</sup>	LSI oscillator power consumption		0.65	1.2	μA

- $V_{DD} = 3$  V,  $T_A = -40$  to  $85$  °C unless otherwise specified.
- Based on characterization, not tested in production.
- Guaranteed by design, not tested in production.

#### Wakeup time from low-power mode

The wakeup times given in [Table 25](#) are measured on a wakeup phase with an 8-MHz HSI RC oscillator. The clock source used to wake up the device depends from the current operating mode:

- Stop or Standby mode: the clock source is the RC oscillator
- Sleep mode: the clock source is the clock that was set before entering Sleep mode.

All timings are derived from tests performed under the ambient temperature and  $V_{DD}$  supply voltage conditions summarized in [Table 8](#).

**Table 25. Low-power mode wakeup timings**

Symbol	Parameter	Typ	Unit
$t_{WUSLEEP}^{(1)}$	Wakeup from Sleep mode	1.8	$\mu\text{s}$
$t_{WUSTOP}^{(1)}$	Wakeup from Stop mode (regulator in run mode)	3.6	$\mu\text{s}$
	Wakeup from Stop mode (regulator in low-power mode)	5.4	
$t_{WUSTDBY}^{(1)}$	Wakeup from Standby mode	50	$\mu\text{s}$

1. The wakeup times are measured from the wakeup event to the point at which the user application code reads the first instruction.

### 5.3.8 PLL characteristics

The parameters given in [Table 26](#) are derived from tests performed under the ambient temperature and  $V_{DD}$  supply voltage conditions summarized in [Table 8](#).

**Table 26. PLL characteristics**

Symbol	Parameter	Value			Unit
		Min <sup>(1)</sup>	Typ	Max <sup>(1)</sup>	
$f_{PLL\_IN}$	PLL input clock <sup>(2)</sup>	1	8.0	25	MHz
	PLL input clock duty cycle	40		60	%
$f_{PLL\_OUT}$	PLL multiplier output clock	16		36	MHz
$t_{LOCK}$	PLL lock time			200	$\mu\text{s}$
Jitter	Cycle-to-cycle jitter			300	ps

1. Based on device characterization, not tested in production.
2. Take care of using the appropriate multiplier factors so as to have PLL input clock values compatible with the range defined by  $f_{PLL\_OUT}$ .

### 5.3.9 Memory characteristics

#### Flash memory

The characteristics are given at  $T_A = -40$  to  $85$  °C unless otherwise specified.

**Table 27. Flash memory characteristics**

Symbol	Parameter	Conditions	Min <sup>(1)</sup>	Typ	Max <sup>(1)</sup>	Unit
$t_{prog}$	16-bit programming time	$T_A = -40$ to $+85$ °C	40	52.5	70	$\mu\text{s}$
$t_{ERASE}$	Page (1 KB) erase time	$T_A = -40$ to $+85$ °C	20		40	ms
$t_{ME}$	Mass erase time	$T_A = -40$ to $+85$ °C	20		40	ms

**Table 27. Flash memory characteristics (continued)**

Symbol	Parameter	Conditions	Min <sup>(1)</sup>	Typ	Max <sup>(1)</sup>	Unit
I <sub>DD</sub>	Supply current	Read mode f <sub>HCLK</sub> = 36 MHz with 1 wait state, V <sub>DD</sub> = 3.3 V			20	mA
		Write / Erase modes f <sub>HCLK</sub> = 36 MHz, V <sub>DD</sub> = 3.3 V			5	mA
		Power-down mode / Halt, V <sub>DD</sub> = 3.0 to 3.6 V			50	μA
V <sub>prog</sub>	Programming voltage		2		3.6	V

1. Guaranteed by design, not tested in production.

**Table 28. Flash memory endurance and data retention**

Symbol	Parameter	Conditions	Value			Unit
			Min <sup>(1)</sup>	Typ	Max	
N <sub>END</sub>	Endurance	T <sub>A</sub> = -40 °C to 85 °C	10			kcycles
t <sub>RET</sub>	Data retention	T <sub>A</sub> = 85 °C, 1 kcycle <sup>(2)</sup>	30			Years
		T <sub>A</sub> = 55 °C, 10 kcycle <sup>(2)</sup>	20			

1. Based on characterization not tested in production.

2. Cycling performed over the whole temperature range.

### 5.3.10 EMC characteristics

Susceptibility tests are performed on a sample basis during device characterization.

#### Functional EMS (Electromagnetic susceptibility)

While a simple application is executed on the device (toggling 2 LEDs through I/O ports), the device is stressed by two electromagnetic events until a failure occurs. The failure is indicated by the LEDs:

- **Electrostatic discharge (ESD)** (positive and negative) is applied to all device pins until a functional disturbance occurs. This test is compliant with the IEC 61000-4-2 standard.
- **FTB:** A Burst of Fast Transient voltage (positive and negative) is applied to V<sub>DD</sub> and V<sub>SS</sub> through a 100 pF capacitor, until a functional disturbance occurs. This test is compliant with the IEC 61000-4-4 standard.

A device reset allows normal operations to be resumed.

The test results are given in [Table 29](#). They are based on the EMS levels and classes defined in application note AN1709.

**Table 29. EMS characteristics**

Symbol	Parameter	Conditions	Level/Class
V <sub>FESD</sub>	Voltage limits to be applied on any I/O pin to induce a functional disturbance	V <sub>DD</sub> = 3.3 V, T <sub>A</sub> = +25 °C, f <sub>HCLK</sub> = 36 MHz conforms to IEC 61000-4-2	2B
V <sub>EFTB</sub>	Fast transient voltage burst limits to be applied through 100 pF on V <sub>DD</sub> and V <sub>SS</sub> pins to induce a functional disturbance	V <sub>DD</sub> = 3.3 V, T <sub>A</sub> = +25 °C, f <sub>HCLK</sub> = 36 MHz conforms to IEC 61000-4-4	4A

**Designing hardened software to avoid noise problems**

EMC characterization and optimization are performed at component level with a typical application environment and simplified MCU software. It should be noted that good EMC performance is highly dependent on the user application and the software in particular.

Therefore it is recommended that the user applies EMC software optimization and pre qualification tests in relation with the EMC level requested for his application.

**Software recommendations**

The software flowchart must include the management of runaway conditions such as:

- Corrupted program counter
- Unexpected reset
- Critical Data corruption (control registers...)

**Prequalification trials**

Most of the common failures (unexpected reset and program counter corruption) can be reproduced by manually forcing a low state on the NRST pin or the Oscillator pins for 1 second. To complete these trials, ESD stress can be applied directly on the device, over the range of specification values. When unexpected behavior is detected, the software can be hardened to prevent unrecoverable errors occurring (see application note AN1015).

**Electromagnetic Interference (EMI)**

The electromagnetic field emitted by the device is monitored while a simple application is executed (toggling 2 LEDs through the I/O ports). This emission test is compliant with IEC61967-2 standard which specifies the test board and the pin loading.

**Table 30. EMI characteristics**

Symbol	Parameter	Conditions	Monitored frequency band	Max vs. [f <sub>HSE</sub> /f <sub>HCLK</sub> ]	Unit
				8/36 MHz	
S <sub>EMI</sub>	Peak level	V <sub>DD</sub> = 3.3 V, T <sub>A</sub> = 25 °C, LQFP100 package compliant with IEC 61967-2	0.1 MHz to 30 MHz	7	dBμV
			30 MHz to 130 MHz	8	
			130 MHz to 1GHz	13	
			SAE EMI Level	3.5	-

### 5.3.11 Absolute maximum ratings (electrical sensitivity)

Based on three different tests (ESD, LU) using specific measurement methods, the device is stressed in order to determine its performance in terms of electrical sensitivity.

#### Electrostatic discharge (ESD)

Electrostatic discharges (a positive then a negative pulse separated by 1 second) are applied to the pins of each sample according to each pin combination. The sample size depends on the number of supply pins in the device (3 parts × (n+1) supply pins). This test conforms to the JESD22-A114/C101 standard.

**Table 31. ESD absolute maximum ratings**

Symbol	Ratings	Conditions	Class	Maximum value <sup>(1)</sup>	Unit
$V_{ESD(HBM)}$	Electrostatic discharge voltage (human body model)	$T_A = +25\text{ °C}$ conforming to JESD22-A114	2	2000	V
$V_{ESD(CDM)}$	Electrostatic discharge voltage (charge device model)	$T_A = +25\text{ °C}$ conforming to JESD22-C101	II	500	

1. Based on characterization results, not tested in production.

#### Static latch-up

Two complementary static tests are required on six parts to assess the latch-up performance:

- A supply overvoltage is applied to each power supply pin
- A current injection is applied to each input, output and configurable I/O pin

These tests are compliant with EIA/JESD 78 IC latch-up standard.

**Table 32. Electrical sensitivities**

Symbol	Parameter	Conditions	Class
LU	Static latch-up class	$T_A = +85\text{ °C}$ conforming to JESD78A	II level A

### 5.3.12 I/O port characteristics

#### General input/output characteristics

Unless otherwise specified, the parameters given in [Table 33](#) are derived from tests performed under the conditions summarized in [Table 8](#). All I/Os are CMOS and TTL compliant.

Table 33. I/O static characteristics

Symbol	Parameter	Conditions	Min	Typ	Max	Unit
V <sub>IL</sub>	Standard I/O input low level voltage		-0.5		0.28 (V <sub>DD</sub> -2)+0.8	V
	I/O FT <sup>(1)</sup> input low level voltage		-0.5		0.32 (V <sub>DD</sub> -2)+0.75	
V <sub>IH</sub>	Standard I/O input high level voltage		0.41 (V <sub>DD</sub> -2)+1.3		V <sub>DD</sub> +0.5	
	I/O FT <sup>(1)</sup> input high level voltage		0.42 (V <sub>DD</sub> -2)+1		5.5	
V <sub>hys</sub>	Standard IO Schmitt trigger voltage hysteresis <sup>(2)</sup>		200			mV
	IO FT Schmitt trigger voltage hysteresis <sup>(2)</sup>		5% V <sub>DD</sub> <sup>(3)</sup>			mV
I <sub>lkg</sub>	Input leakage current <sup>(4)</sup>	V <sub>SS</sub> ≤ V <sub>IN</sub> ≤ V <sub>DD</sub> Standard I/Os			±1	μA
		V <sub>IN</sub> = 5 V I/O FT			3	
R <sub>PU</sub>	Weak pull-up equivalent resistor <sup>(5)</sup>	V <sub>IN</sub> = V <sub>SS</sub>	30	40	50	kΩ
R <sub>PD</sub>	Weak pull-down equivalent resistor <sup>(5)</sup>	V <sub>IN</sub> = V <sub>DD</sub>	30	40	50	kΩ
C <sub>IO</sub>	I/O pin capacitance			5		pF

1. FT = 5V tolerant. To sustain a voltage higher than V<sub>DD</sub>+0.5 the internal pull-up/pull-down resistors must be disabled.
2. Hysteresis voltage between Schmitt trigger switching levels. Based on characterization, not tested in production.
3. With a minimum of 100 mV.
4. Leakage could be higher than max. if negative current is injected on adjacent pins.
5. Pull-up and pull-down resistors are designed with a true resistance in series with a switchable PMOS/NMOS. This PMOS/NMOS contribution to the series resistance is minimum (~10% order).

All I/Os are CMOS and TTL compliant (no software configuration required). Their characteristics cover more than the strict CMOS-technology or TTL parameters. The coverage of these requirements is shown in [Figure 22](#) and [Figure 23](#) for standard I/Os, and in [Figure 24](#) and [Figure 25](#) for 5 V tolerant I/Os.

Figure 22. Standard I/O input characteristics - CMOS port

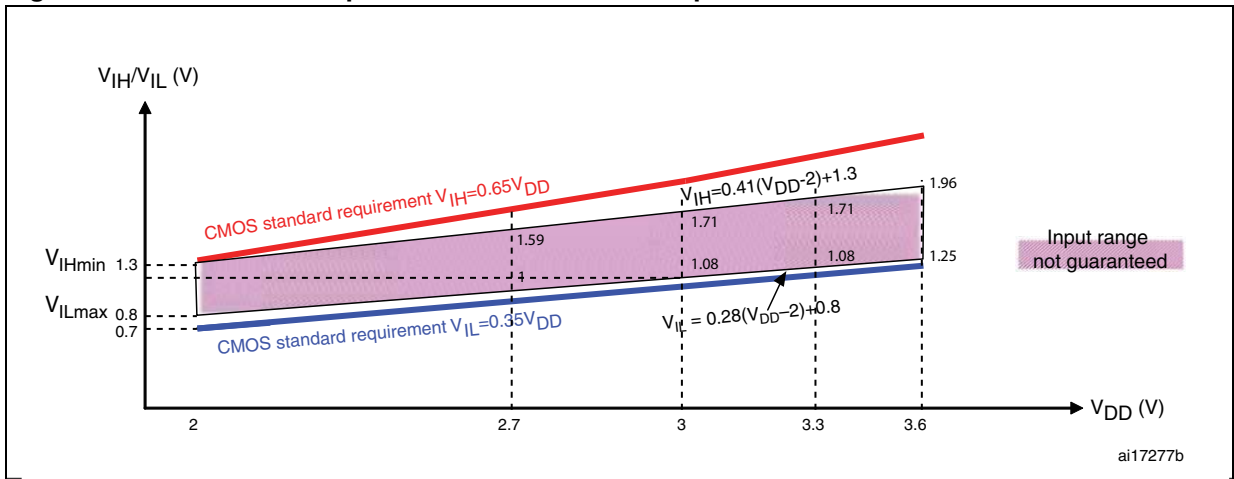

Figure 23. Standard I/O input characteristics - TTL port

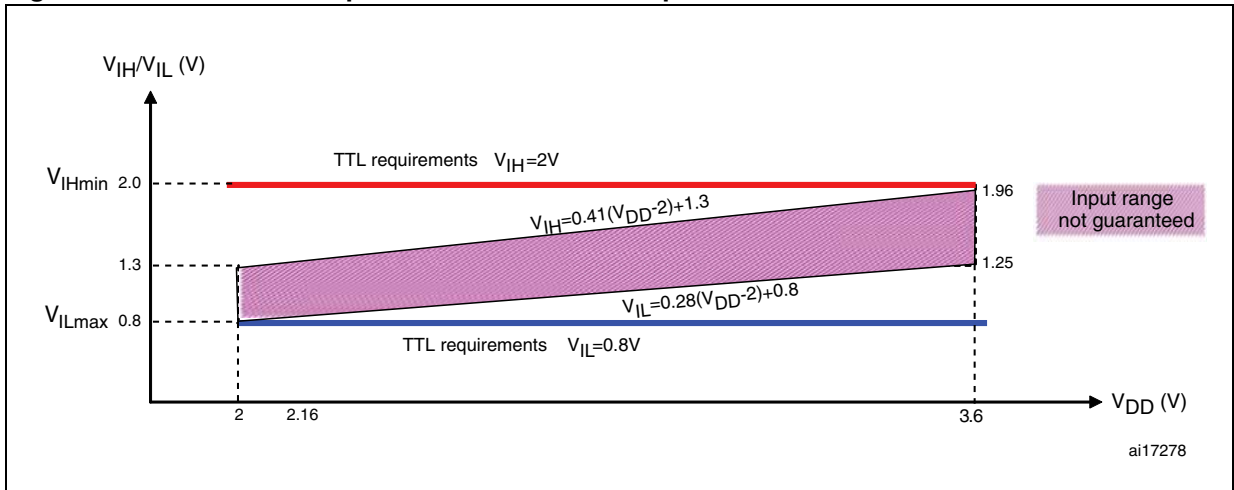

Figure 24. 5 V tolerant I/O input characteristics - CMOS port

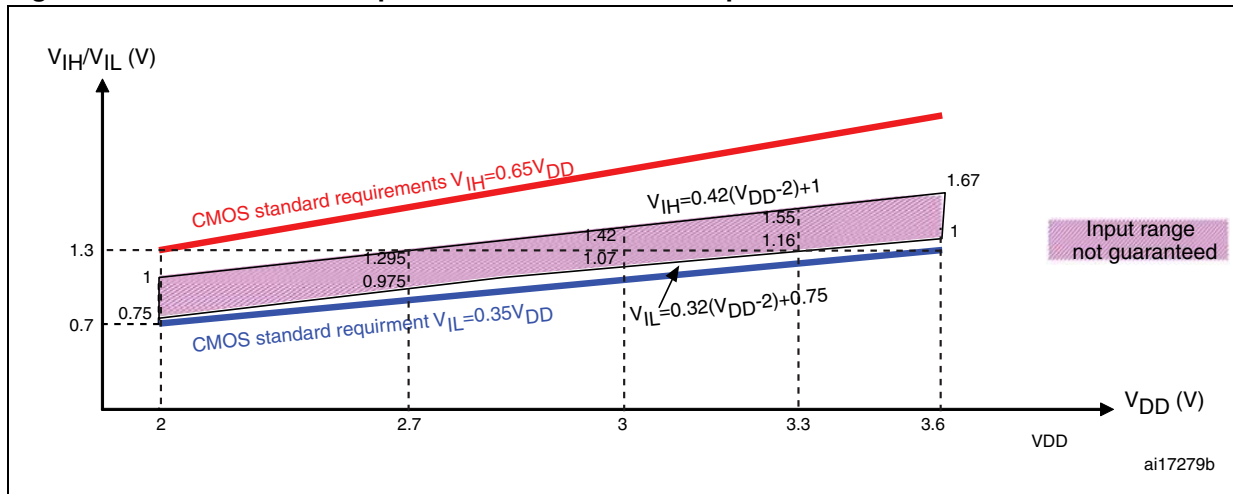
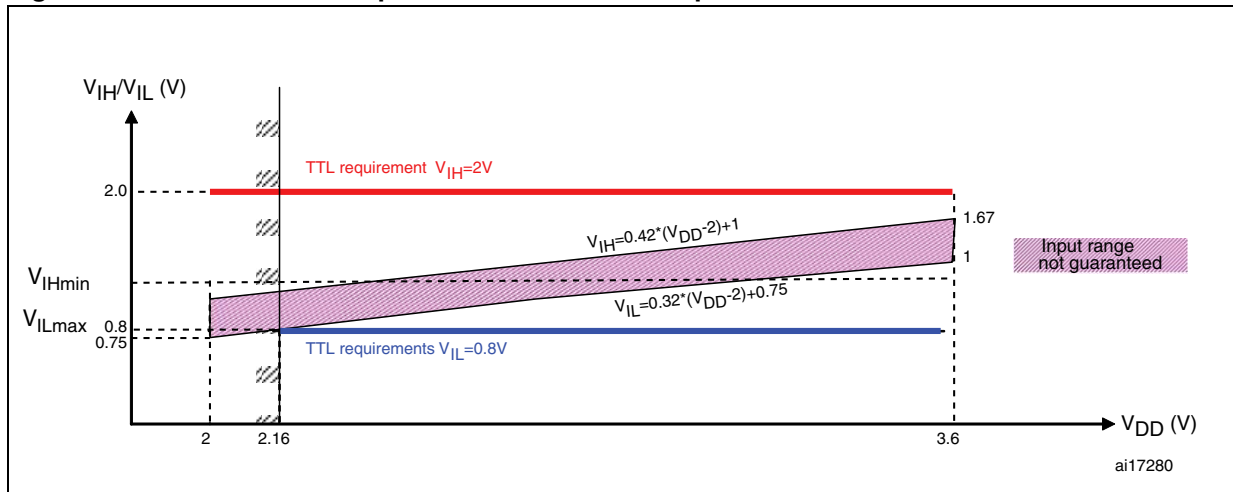

Figure 25. 5 V tolerant I/O input characteristics - TTL port



### Output driving current

The GPIOs (general-purpose inputs/outputs) can sink or source up to  $\pm 8$  mA, and sink or source up to  $\pm 20$  mA (with a relaxed  $V_{OL}/V_{OH}$ ).

In the user application, the number of I/O pins which can drive current must be limited to respect the absolute maximum rating specified in [Section 5.2](#):

- The sum of the currents sourced by all the I/Os on  $V_{DD}$ , plus the maximum Run consumption of the MCU sourced on  $V_{DD}$ , cannot exceed the absolute maximum rating  $I_{VDD}$  (see [Table 6](#)).
- The sum of the currents sunk by all the I/Os on  $V_{SS}$  plus the maximum Run consumption of the MCU sunk on  $V_{SS}$  cannot exceed the absolute maximum rating  $I_{VSS}$  (see [Table 6](#)).

### Output voltage levels

Unless otherwise specified, the parameters given in [Table 34](#) are derived from tests performed under the ambient temperature and  $V_{DD}$  supply voltage conditions summarized in [Table 8](#). All I/Os are CMOS and TTL compliant.

**Table 34. Output voltage characteristics**

Symbol	Parameter	Conditions	Min	Max	Unit
$V_{OL}^{(1)}$	Output Low level voltage for an I/O pin when 8 pins are sunk at the same time	TTL port, $I_{IO} = +8 \text{ mA}$ , $2.7 \text{ V} < V_{DD} < 3.6 \text{ V}$		0.4	V
$V_{OH}^{(2)}$	Output High level voltage for an I/O pin when 8 pins are sourced at the same time		$V_{DD}-0.4$		
$V_{OL}^{(1)}$	Output low level voltage for an I/O pin when 8 pins are sunk at the same time	CMOS port $I_{IO} = +8 \text{ mA}$ $2.7 \text{ V} < V_{DD} < 3.6 \text{ V}$		0.4	V
$V_{OH}^{(2)}$	Output high level voltage for an I/O pin when 8 pins are sourced at the same time		2.4		
$V_{OL}^{(1)}$	Output low level voltage for an I/O pin when 8 pins are sunk at the same time	$I_{IO} = +20 \text{ mA}^{(3)}$ $2.7 \text{ V} < V_{DD} < 3.6 \text{ V}$		1.3	V
$V_{OH}^{(2)}$	Output high level voltage for an I/O pin when 8 pins are sourced at the same time		$V_{DD}-1.3$		
$V_{OL}^{(1)}$	Output low level voltage for an I/O pin when 8 pins are sunk at the same time	$I_{IO} = +6 \text{ mA}^{(3)}$ $2 \text{ V} < V_{DD} < 2.7 \text{ V}$		0.4	V
$V_{OH}^{(2)}$	Output high level voltage for an I/O pin when 8 pins are sourced at the same time		$V_{DD}-0.4$		

1. The  $I_{IO}$  current sunk by the device must always respect the absolute maximum rating specified in [Table 6](#) and the sum of  $I_{IO}$  (I/O ports and control pins) must not exceed  $I_{VSS}$ .
2. The  $I_{IO}$  current sourced by the device must always respect the absolute maximum rating specified in [Table 6](#) and the sum of  $I_{IO}$  (I/O ports and control pins) must not exceed  $I_{VDD}$ .
3. Based on characterization data, not tested in production.

**Input/output AC characteristics**

The definition and values of input/output AC characteristics are given in [Figure 26](#) and [Table 35](#), respectively.

Unless otherwise specified, the parameters given in [Table 35](#) are derived from tests performed under the ambient temperature and  $V_{DD}$  supply voltage conditions summarized in [Table 8](#).

**Table 35. I/O AC characteristics<sup>(1)</sup>**

MODEx [1:0] bit value <sup>(1)</sup>	Symbol	Parameter	Conditions	Max	Unit
10	$f_{max(I/O)out}$	Maximum frequency <sup>(2)</sup>	$C_L = 50 \text{ pF}, V_{DD} = 2 \text{ V to } 3.6 \text{ V}$	2	MHz
	$t_{f(I/O)out}$	Output high to low level fall time	$C_L = 50 \text{ pF}, V_{DD} = 2 \text{ V to } 3.6 \text{ V}$	125 <sup>(3)</sup>	ns
	$t_{r(I/O)out}$	Output low to high level rise time		125 <sup>(3)</sup>	
01	$f_{max(I/O)out}$	Maximum frequency <sup>(2)</sup>	$C_L = 50 \text{ pF}, V_{DD} = 2 \text{ V to } 3.6 \text{ V}$	10	MHz
	$t_{f(I/O)out}$	Output high to low level fall time	$C_L = 50 \text{ pF}, V_{DD} = 2 \text{ V to } 3.6 \text{ V}$	25 <sup>(3)</sup>	ns
	$t_{r(I/O)out}$	Output low to high level rise time		25 <sup>(3)</sup>	
11	$F_{max(I/O)out}$	Maximum Frequency <sup>(2)</sup>	$C_L = 30 \text{ pF}, V_{DD} = 2.7 \text{ V to } 3.6 \text{ V}$	50	MHz
			$C_L = 50 \text{ pF}, V_{DD} = 2.7 \text{ V to } 3.6 \text{ V}$	30	
			$C_L = 50 \text{ pF}, V_{DD} = 2 \text{ V to } 2.7 \text{ V}$	20	
	$t_{f(I/O)out}$	Output high to low level fall time	$C_L = 30 \text{ pF}, V_{DD} = 2.7 \text{ V to } 3.6 \text{ V}$	5 <sup>(3)</sup>	ns
			$C_L = 50 \text{ pF}, V_{DD} = 2.7 \text{ V to } 3.6 \text{ V}$	8 <sup>(3)</sup>	
			$C_L = 50 \text{ pF}, V_{DD} = 2 \text{ V to } 2.7 \text{ V}$	12 <sup>(3)</sup>	
	$t_{r(I/O)out}$	Output low to high level rise time	$C_L = 30 \text{ pF}, V_{DD} = 2.7 \text{ V to } 3.6 \text{ V}$	5 <sup>(3)</sup>	
			$C_L = 50 \text{ pF}, V_{DD} = 2.7 \text{ V to } 3.6 \text{ V}$	8 <sup>(3)</sup>	
			$C_L = 50 \text{ pF}, V_{DD} = 2 \text{ V to } 2.7 \text{ V}$	12 <sup>(3)</sup>	
-	$t_{EXTIpw}$	Pulse width of external signals detected by the EXTI controller		10	ns

1. The I/O speed is configured using the MODEx[1:0] bits. Refer to the STM32F10xxx reference manual for a description of GPIO Port configuration register.
2. The maximum frequency is defined in [Figure 26](#).
3. Guaranteed by design, not tested in production.

Figure 26. I/O AC characteristics definition

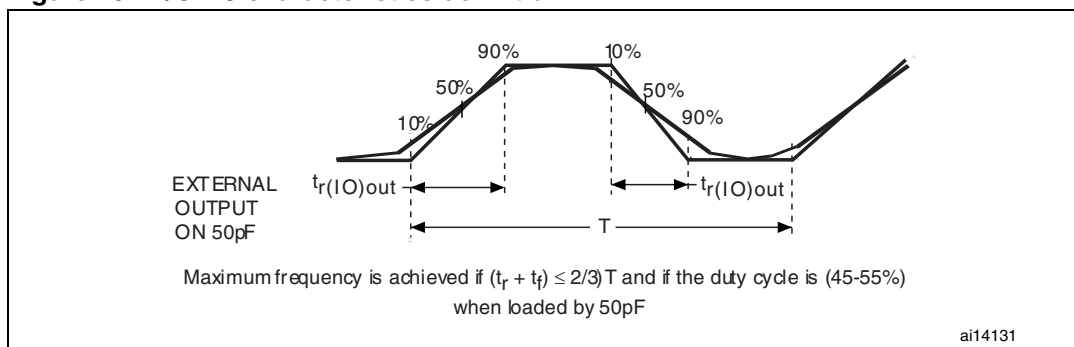

### 5.3.13 NRST pin characteristics

The NRST pin input driver uses CMOS technology. It is connected to a permanent pull-up resistor,  $R_{PU}$  (see Table 33).

Unless otherwise specified, the parameters given in Table 36 are derived from tests performed under the ambient temperature and  $V_{DD}$  supply voltage conditions summarized in Table 8.

Table 36. NRST pin characteristics

Symbol	Parameter	Conditions	Min	Typ	Max	Unit
$V_{IL(NRST)}^{(1)}$	NRST Input low level voltage		-0.5		0.8	V
$V_{IH(NRST)}^{(1)}$	NRST Input high level voltage		2		$V_{DD}+0.5$	
$V_{hys(NRST)}$	NRST Schmitt trigger voltage hysteresis			200		mV
$R_{PU}$	Weak pull-up equivalent resistor <sup>(2)</sup>	$V_{IN} = V_{SS}$	30	40	50	k $\Omega$
$V_F(NRST)^{(1)}$	NRST Input filtered pulse				100	ns
$V_{NF(NRST)}^{(1)}$	NRST Input not filtered pulse		300			ns

1. Guaranteed by design, not tested in production.
2. The pull-up is designed with a true resistance in series with a switchable PMOS. This PMOS contribution to the series resistance must be minimum (~10% order).

Figure 27. Recommended NRST pin protection

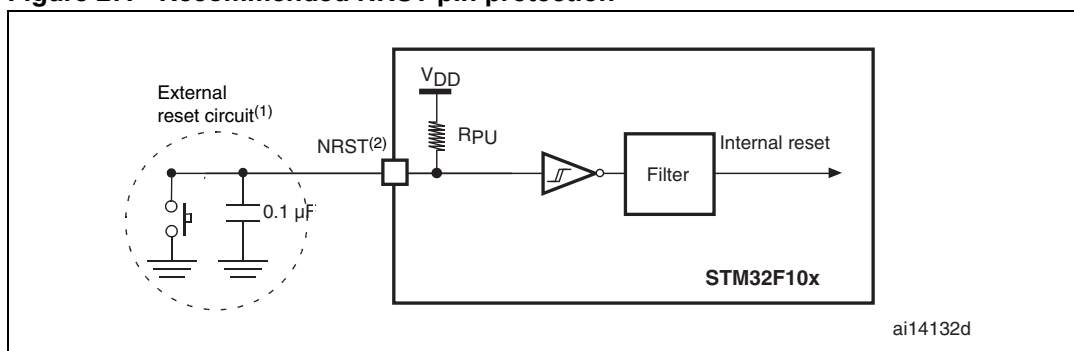

1. The reset network protects the device against parasitic resets.
2. The user must ensure that the level on the NRST pin can go below the  $V_{IL(NRST)}$  max level specified in Table 36. Otherwise the reset will not be taken into account by the device.

### 5.3.14 TIM timer characteristics

The parameters given in [Table 37](#) are guaranteed by design.

Refer to [Section 5.3.12: I/O port characteristics](#) for details on the input/output alternate function characteristics (output compare, input capture, external clock, PWM output).

**Table 37. TIMx<sup>(1)</sup> characteristics**

Symbol	Parameter	Conditions	Min	Max	Unit
$t_{res(TIM)}$	Timer resolution time		1		$t_{TIMxCLK}$
		$f_{TIMxCLK} = 36 \text{ MHz}$	27.8		ns
$f_{EXT}$	Timer external clock frequency on CH1 to CH4		0	$f_{TIMxCLK}/2$	MHz
		$f_{TIMxCLK} = 36 \text{ MHz}$	0	18	MHz
$Res_{TIM}$	Timer resolution			16	bit
$t_{COUNTER}$	16-bit counter clock period when internal clock is selected		1	65536	$t_{TIMxCLK}$
		$f_{TIMxCLK} = 36 \text{ MHz}$	0.0278	1820	$\mu\text{s}$
$t_{MAX\_COUNT}$	Maximum possible count			$65536 \times 65536$	$t_{TIMxCLK}$
		$f_{TIMxCLK} = 36 \text{ MHz}$		119.2	s

1. TIMx is used as a general term to refer to the TIM2, TIM3 and TIM4 timers.

### 5.3.15 Communications interfaces

#### I<sup>2</sup>C interface characteristics

Unless otherwise specified, the parameters given in [Table 38](#) are derived from tests performed under the ambient temperature,  $f_{PCLK1}$  frequency and  $V_{DD}$  supply voltage conditions summarized in [Table 8](#).

The STM32F101xx Low-density access line I<sup>2</sup>C interface meets the requirements of the standard I<sup>2</sup>C communication protocol with the following restrictions: the I/O pins SDA and SCL are mapped to are not “true” open-drain. When configured as open-drain, the PMOS connected between the I/O pin and  $V_{DD}$  is disabled, but is still present.

The I<sup>2</sup>C characteristics are described in [Table 38](#). Refer also to [Section 5.3.12: I/O port characteristics](#) for more details on the input/output alternate function characteristics (SDA and SCL).

Table 38. I<sup>2</sup>C characteristics

Symbol	Parameter	Standard mode I <sup>2</sup> C <sup>(1)</sup>		Fast mode I <sup>2</sup> C <sup>(1)(2)</sup>		Unit
		Min	Max	Min	Max	
t <sub>w(SCLL)</sub>	SCL clock low time	4.7		1.3		μs
t <sub>w(SCLH)</sub>	SCL clock high time	4.0		0.6		
t <sub>su(SDA)</sub>	SDA setup time	250		100		ns
t <sub>h(SDA)</sub>	SDA data hold time	0 <sup>(3)</sup>		0 <sup>(4)</sup>	900 <sup>(3)</sup>	
t <sub>r(SDA)</sub> t <sub>r(SCL)</sub>	SDA and SCL rise time		1000	20+0.1C <sub>b</sub>	300	
t <sub>f(SDA)</sub> t <sub>f(SCL)</sub>	SDA and SCL fall time		300		300	
t <sub>h(STA)</sub>	Start condition hold time	4.0		0.6		μs
t <sub>su(STA)</sub>	Repeated Start condition setup time	4.7		0.6		
t <sub>su(STO)</sub>	Stop condition setup time	4.0		0.6		μs
t <sub>w(STO:STA)</sub>	Stop to Start condition time (bus free)	4.7		1.3		μs
C <sub>b</sub>	Capacitive load for each bus line		400		400	pF

1. Guaranteed by design, not tested in production.
2. f<sub>PCLK1</sub> must be higher than 2 MHz to achieve standard mode I<sup>2</sup>C frequencies. It must be higher than 4 MHz to achieve fast mode I<sup>2</sup>C frequencies. It must be a multiple of 10 MHz to reach the 400 kHz maximum I<sup>2</sup>C fast mode clock.
3. The maximum hold time of the Start condition has only to be met if the interface does not stretch the low period of SCL signal.
4. The device must internally provide a hold time of at least 300 ns for the SDA signal in order to bridge the undefined region of the falling edge of SCL.

Figure 28. I<sup>2</sup>C bus AC waveforms and measurement circuit<sup>(1)</sup>

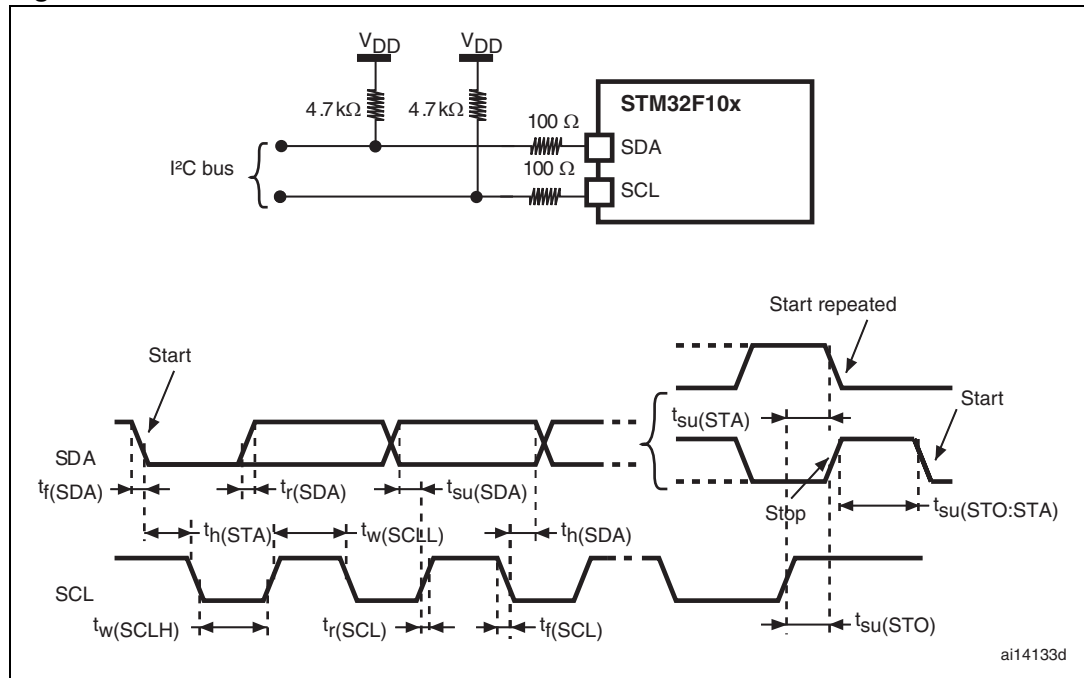

1. Measurement points are done at CMOS levels: 0.3V<sub>DD</sub> and 0.7V<sub>DD</sub>.

Table 39. SCL frequency (f<sub>PCLK1</sub>= MHz, V<sub>DD</sub> = 3.3 V)<sup>(1)(2)</sup>

f <sub>SCL</sub> (kHz)	I2C_CCR value
	R <sub>P</sub> = 4.7 kΩ
400	0x801E
300	0x8028
200	0x803C
100	0x00B4
50	0x0168
20	0x0384

1. R<sub>P</sub> = External pull-up resistance, f<sub>SCL</sub> = I<sup>2</sup>C speed,
2. For speeds around 200 kHz, the tolerance on the achieved speed is of ±5%. For other speed ranges, the tolerance on the achieved speed ±2%. These variations depend on the accuracy of the external components used to design the application.

### SPI interface characteristics

Unless otherwise specified, the parameters given in [Table 40](#) are derived from tests performed under the ambient temperature,  $f_{PCLKx}$  frequency and  $V_{DD}$  supply voltage conditions summarized in [Table 8](#).

Refer to [Section 5.3.12: I/O port characteristics](#) for more details on the input/output alternate function characteristics (NSS, SCK, MOSI, MISO).

**Table 40. SPI characteristics<sup>(1)</sup>**

Symbol	Parameter	Conditions	Min	Max	Unit
$f_{SCK}$ $1/t_c(SCK)$	SPI clock frequency	Master mode	0	18	MHz
		Slave mode	0	18	
$t_r(SCK)$ $t_f(SCK)$	SPI clock rise and fall time	Capacitive load: C = 30 pF		8	ns
$t_{su(NSS)}^{(2)}$	NSS setup time	Slave mode	$4 t_{PCLK}$		
$t_h(NSS)^{(2)}$	NSS hold time	Slave mode	73		
$t_w(SCKH)^{(2)}$ $t_w(SCKL)^{(2)}$	SCK high and low time	Master mode, $f_{PCLK} = 36$ MHz, presc = 4	50	60	
$t_{su(MI)}^{(2)}$	Data input setup time Master mode	SPI	1		
$t_{su(SI)}^{(2)}$	Data input setup time Slave mode		1		
$t_h(MI)^{(2)}$	Data input hold time Master mode	SPI	1		
$t_h(SI)^{(2)}$	Data input hold time Slave mode		3		
$t_{a(SO)}^{(2)(3)}$	Data output access time	Slave mode, $f_{PCLK} = 36$ MHz, presc = 4	0	55	
		Slave mode, $f_{PCLK} = 24$ MHz	0	$4 t_{PCLK}$	
$t_{dis(SO)}^{(2)(4)}$	Data output disable time	Slave mode	10		
$t_v(SO)^{(2)(1)}$	Data output valid time	Slave mode (after enable edge)		25	
$t_v(MO)^{(2)(1)}$	Data output valid time	Master mode (after enable edge)		3	
$t_h(SO)^{(2)}$	Data output hold time	Slave mode (after enable edge)	25		
$t_h(MO)^{(2)}$		Master mode (after enable edge)	4		

1. Remapped SPI characteristics to be determined.
2. Based on characterization, not tested in production.
3. Min time is for the minimum time to drive the output and the max time is for the maximum time to validate the data.
4. Min time is for the minimum time to invalidate the output and the max time is for the maximum time to put the data in Hi-Z

Figure 29. SPI timing diagram - slave mode and CPHA = 0

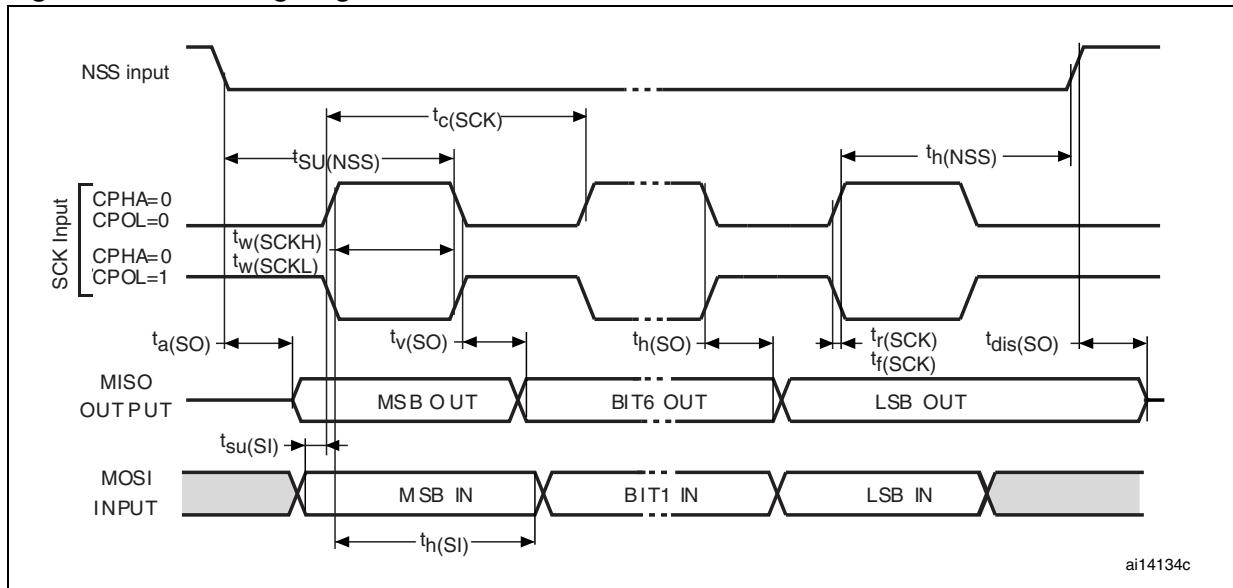

ai14134c

Figure 30. SPI timing diagram - slave mode and CPHA = 1<sup>(1)</sup>

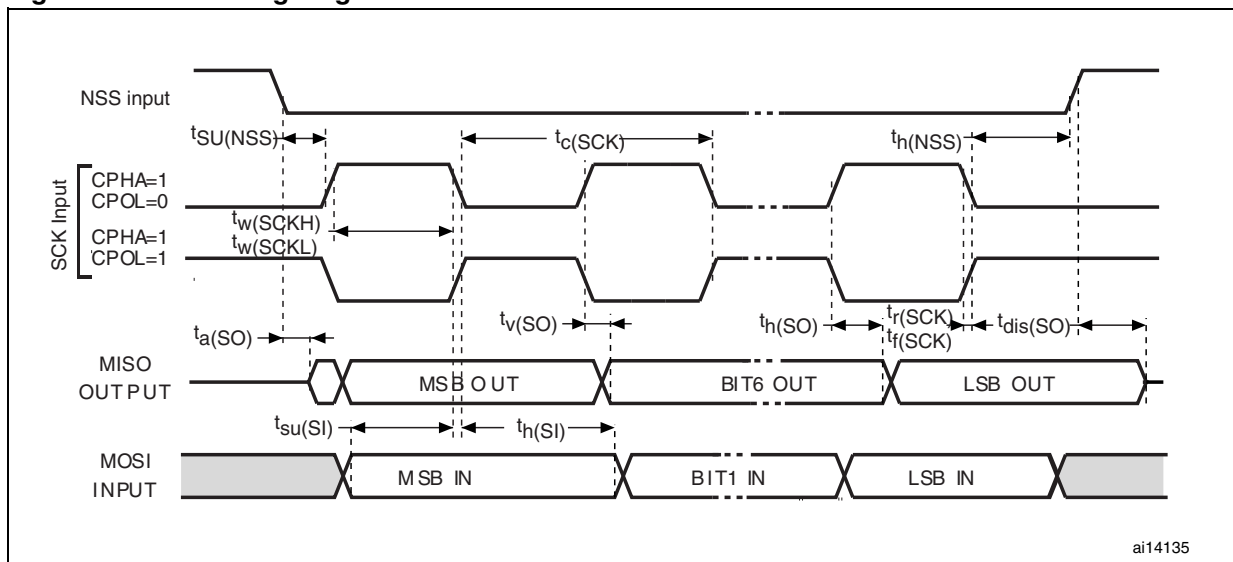

ai14135

1. Measurement points are done at CMOS levels: 0.3V<sub>DD</sub> and 0.7V<sub>DD</sub>.

Figure 31. SPI timing diagram - master mode<sup>(1)</sup>

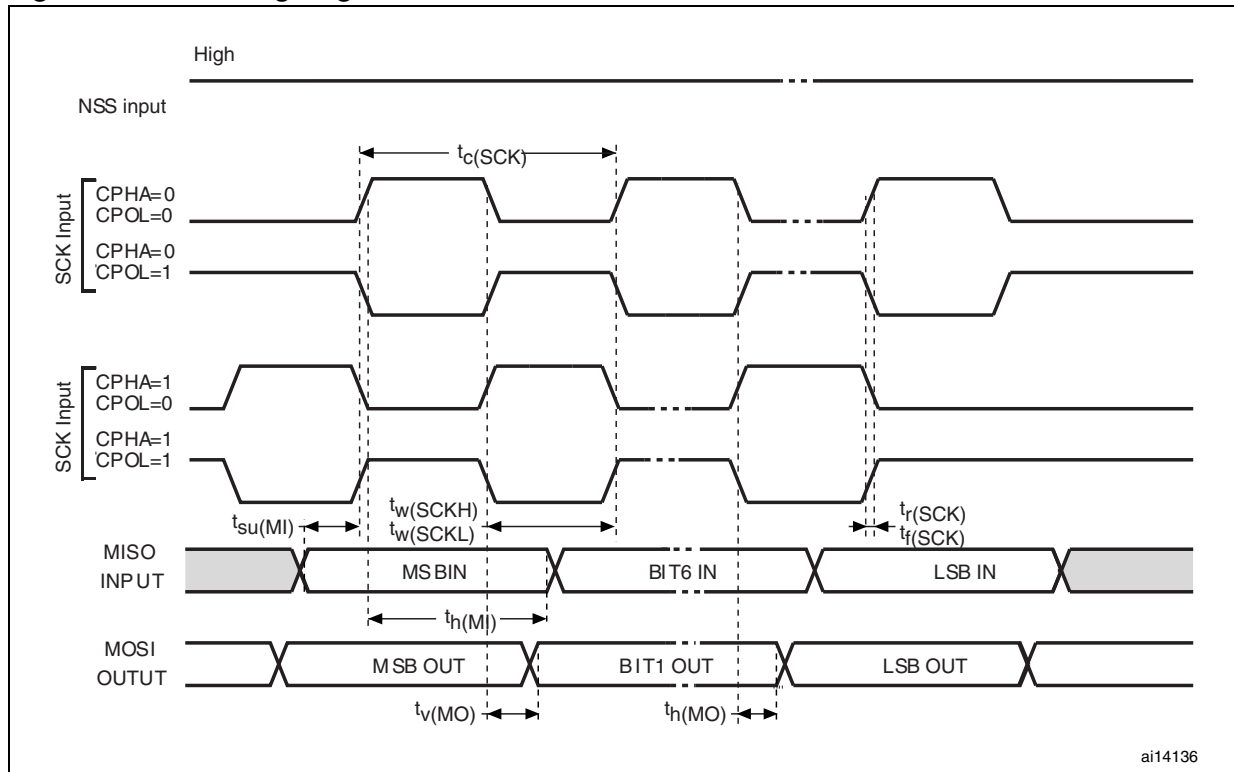

1. Measurement points are done at CMOS levels:  $0.3V_{DD}$  and  $0.7V_{DD}$ .

### 5.3.16 12-bit ADC characteristics

Unless otherwise specified, the parameters given in [Table 41](#) are derived from tests performed under the ambient temperature,  $f_{PCLK2}$  frequency and  $V_{DDA}$  supply voltage conditions summarized in [Table 8](#).

*Note:* It is recommended to perform a calibration after each power-up.

**Table 41. ADC characteristics**

Symbol	Parameter	Conditions	Min	Typ	Max	Unit
$V_{DDA}$	Power supply		2.4		3.6	V
$f_{ADC}$	ADC clock frequency		0.6		14	MHz
$f_S^{(1)}$	Sampling rate		0.05		1	MHz
$f_{TRIG}^{(1)}$	External trigger frequency	$f_{ADC} = 14$ MHz			823	kHz
					17	$1/f_{ADC}$
$V_{AIN}$	Conversion voltage range <sup>(2)</sup>		0 ( $V_{SSA}$ or $V_{REF}$ -tied to ground)		$V_{REF+}$	V
$R_{AIN}^{(1)}$	External input impedance	See <a href="#">Equation 1</a> and <a href="#">Table 42</a> for details			50	$k\Omega$
$R_{ADC}^{(1)}$	Sampling switch resistance				1	$k\Omega$
$C_{ADC}^{(1)}$	Internal sample and hold capacitor				8	pF
$t_{CAL}^{(1)}$	Calibration time	$f_{ADC} = 14$ MHz	5.9			$\mu s$
			83			$1/f_{ADC}$
$t_{lat}^{(1)}$	Injection trigger conversion latency	$f_{ADC} =$ MHz			0.214	$\mu s$
					3 <sup>(3)</sup>	$1/f_{ADC}$
$t_{latr}^{(1)}$	Regular trigger conversion latency	$f_{ADC} = 14$ MHz			0.143	$\mu s$
					2 <sup>(3)</sup>	$1/f_{ADC}$
$t_S^{(1)}$	Sampling time	$f_{ADC} = 14$ MHz	0.107		17.1	$\mu s$
			1.5		239.5	$1/f_{ADC}$
$t_{STAB}^{(1)}$	Power-up time		0	0	1	$\mu s$
$t_{CONV}^{(1)}$	Total conversion time (including sampling time)	$f_{ADC} = 14$ MHz	1		18	$\mu s$
			14 to 252 ( $t_S$ for sampling +12.5 for successive approximation)			$1/f_{ADC}$

1. Guaranteed by design, not tested in production.
2.  $V_{REF+}$  is internally connected to  $V_{DDA}$  and  $V_{REF-}$  is internally connected to  $V_{SSA}$ .
3. For external triggers, a delay of  $1/f_{PCLK2}$  must be added to the latency specified in [Table 41](#).

**Equation 1: R<sub>AIN</sub> max formula:**

$$R_{AIN} < \frac{T_S}{f_{ADC} \times C_{ADC} \times \ln(2^{N+2})} - R_{ADC}$$

The formula above ([Equation 1](#)) is used to determine the maximum external impedance allowed for an error below 1/4 of LSB. Here N = 12 (from 12-bit resolution).

**Table 42. R<sub>AIN</sub> max for f<sub>ADC</sub> = 14 MHz<sup>(1)</sup>**

T <sub>s</sub> (cycles)	t <sub>s</sub> (μs)	R <sub>AIN</sub> max (kΩ)
1.5	0.11	0.4
7.5	0.54	5.9
13.5	0.96	11.4
28.5	2.04	25.2
41.5	2.96	37.2
55.5	3.96	50
71.5	5.11	NA
239.5	17.1	NA

1. Guaranteed by design, not tested in production.

**Table 43. ADC accuracy - limited test conditions<sup>(1) (2)</sup>**

Symbol	Parameter	Test conditions	Typ	Max <sup>(3)</sup>	Unit
ET	Total unadjusted error	f <sub>PCLK2</sub> = 28 MHz, f <sub>ADC</sub> = 14 MHz, R <sub>AIN</sub> < 10 kΩ, V <sub>DDA</sub> = 3 V to 3.6 V T <sub>A</sub> = 25 °C Measurements made after ADC calibration	±1.3	±2	LSB
EO	Offset error		±1	±1.5	
EG	Gain error		±0.5	±1.5	
ED	Differential linearity error		±0.7	±1	
EL	Integral linearity error		±0.8	±1.5	

- ADC DC accuracy values are measured after internal calibration.
- ADC Accuracy vs. Negative Injection Current: Injecting negative current on any of the standard (non-robust) analog input pins should be avoided as this significantly reduces the accuracy of the conversion being performed on another analog input. It is recommended to add a Schottky diode (pin to ground) to standard analog pins which may potentially inject negative current. Any positive injection current within the limits specified for I<sub>INJ(PIN)</sub> and ΣI<sub>INJ(PIN)</sub> in [Section 5.3.12](#) does not affect the ADC accuracy.
- Based on characterization, not tested in production.

**Table 44. ADC accuracy<sup>(1) (2) (3)</sup>**

Symbol	Parameter	Test conditions	Typ	Max <sup>(4)</sup>	Unit
ET	Total unadjusted error	$f_{PCLK2} = 28 \text{ MHz}$ , $f_{ADC} = 14 \text{ MHz}$ , $R_{AIN} < 10 \text{ k}\Omega$ , $V_{DDA} = 2.4 \text{ V to } 3.6 \text{ V}$ Measurements made after ADC calibration	$\pm 2$	$\pm 5$	LSB
EO	Offset error		$\pm 1.5$	$\pm 2.5$	
EG	Gain error		$\pm 1.5$	$\pm 3$	
ED	Differential linearity error		$\pm 1$	$\pm 2$	
EL	Integral linearity error		$\pm 1.5$	$\pm 3$	

1. ADC DC accuracy values are measured after internal calibration.
2. Better performance could be achieved in restricted  $V_{DD}$ , frequency and temperature ranges.
3. ADC Accuracy vs. Negative Injection Current: Injecting negative current on any of the standard (non-robust) analog input pins should be avoided as this significantly reduces the accuracy of the conversion being performed on another analog input. It is recommended to add a Schottky diode (pin to ground) to standard analog pins which may potentially inject negative current. Any positive injection current within the limits specified for  $I_{INJ(PIN)}$  and  $\Sigma I_{INJ(PIN)}$  in [Section 5.3.12](#) does not affect the ADC accuracy.
4. Based on characterization, not tested in production.

**Figure 32. ADC accuracy characteristics**

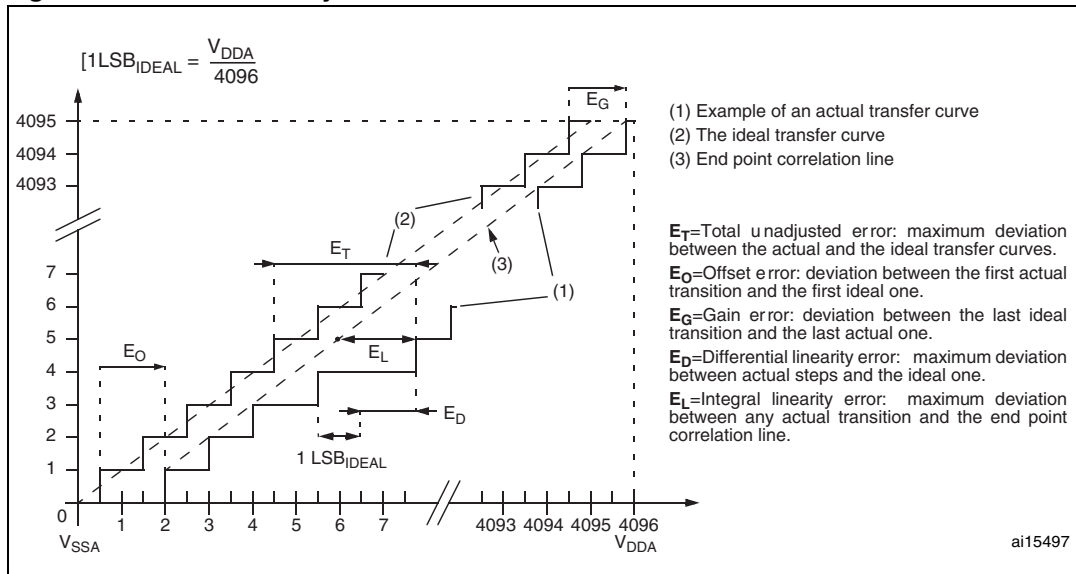
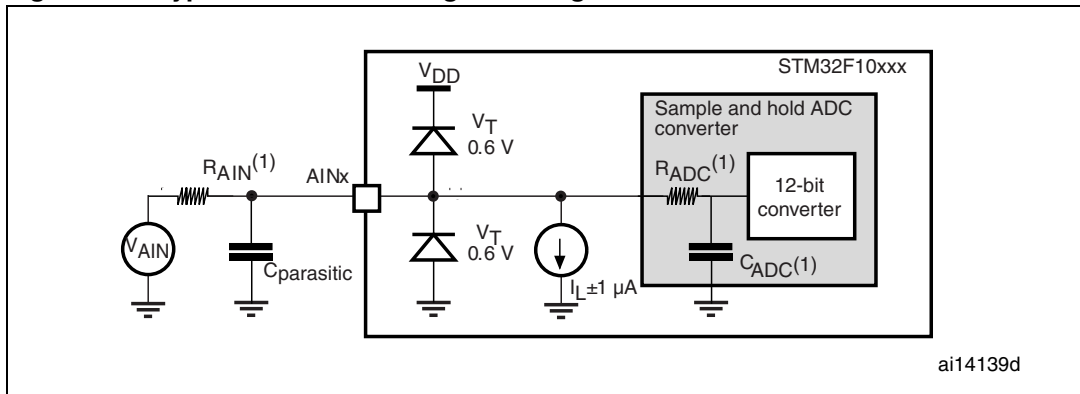

Figure 33. Typical connection diagram using the ADC



1. Refer to [Table 41](#) for the values of  $R_{AIN}$ ,  $R_{ADC}$  and  $C_{ADC}$ .
2.  $C_{parasitic}$  represents the capacitance of the PCB (dependent on soldering and PCB layout quality) plus the pad capacitance (roughly 7 pF). A high  $C_{parasitic}$  value will downgrade conversion accuracy. To remedy this,  $f_{ADC}$  should be reduced.

**General PCB design guidelines**

Power supply decoupling should be performed as shown in [Figure 34](#). The 10 nF capacitors should be ceramic (good quality). They should be placed them as close as possible to the chip.

Figure 34. Power supply and reference decoupling

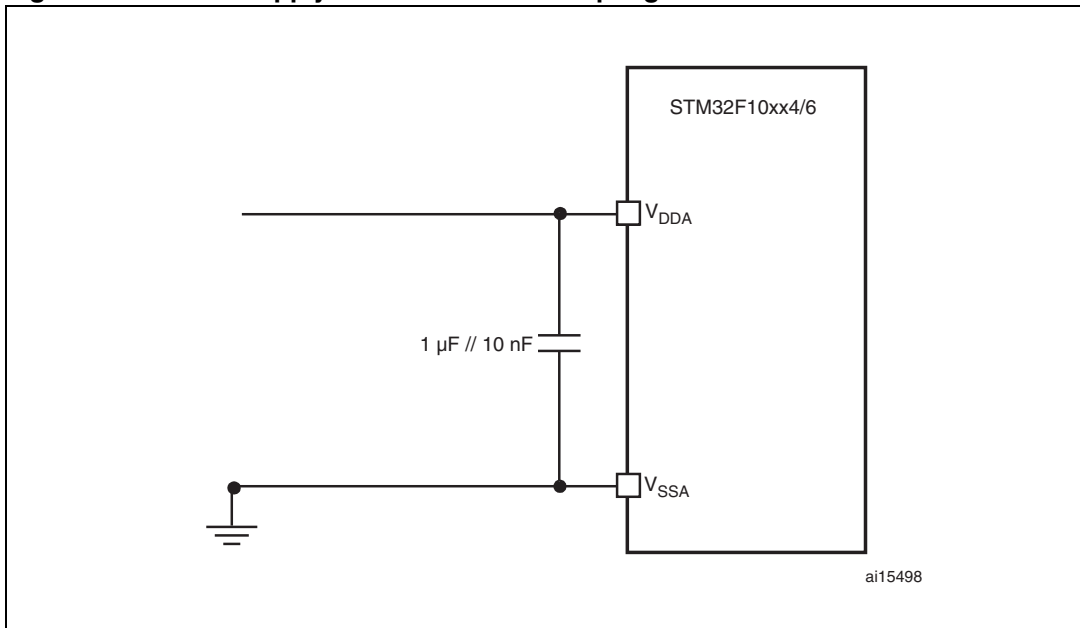

### 5.3.17 Temperature sensor characteristics

**Table 45. TS characteristics**

Symbol	Parameter	Min	Typ	Max	Unit
$T_L^{(1)}$	$V_{SENSE}$ linearity with temperature		$\pm 1$	$\pm 2$	$^{\circ}\text{C}$
Avg_Slope <sup>(1)</sup>	Average slope	4.0	4.3	4.6	mV/ $^{\circ}\text{C}$
$V_{25}^{(1)}$	Voltage at 25 $^{\circ}\text{C}$	1.34	1.43	1.52	V
$t_{START}^{(2)}$	Startup time	4		10	$\mu\text{s}$
$T_{S\_temp}^{(3)(2)}$	ADC sampling time when reading the temperature			17.1	$\mu\text{s}$

1. Guaranteed by characterization, not tested in production.
2. Guaranteed by design, not tested in production.
3. Shortest sampling time can be determined in the application by multiple iterations.

## 6 Package characteristics

### 6.1 Package mechanical data

In order to meet environmental requirements, ST offers these devices in different grades of ECOPACK<sup>®</sup> packages, depending on their level of environmental compliance. ECOPACK<sup>®</sup> specifications, grade definitions and product status are available at: [www.st.com](http://www.st.com). ECOPACK<sup>®</sup> is an ST trademark.

**Figure 35. VFQFPN48 7 x 7 mm, 0.5 mm pitch, package outline<sup>(1)</sup>** **Figure 36. Recommended footprint (dimensions in mm)<sup>(1)(2)(3)</sup>**

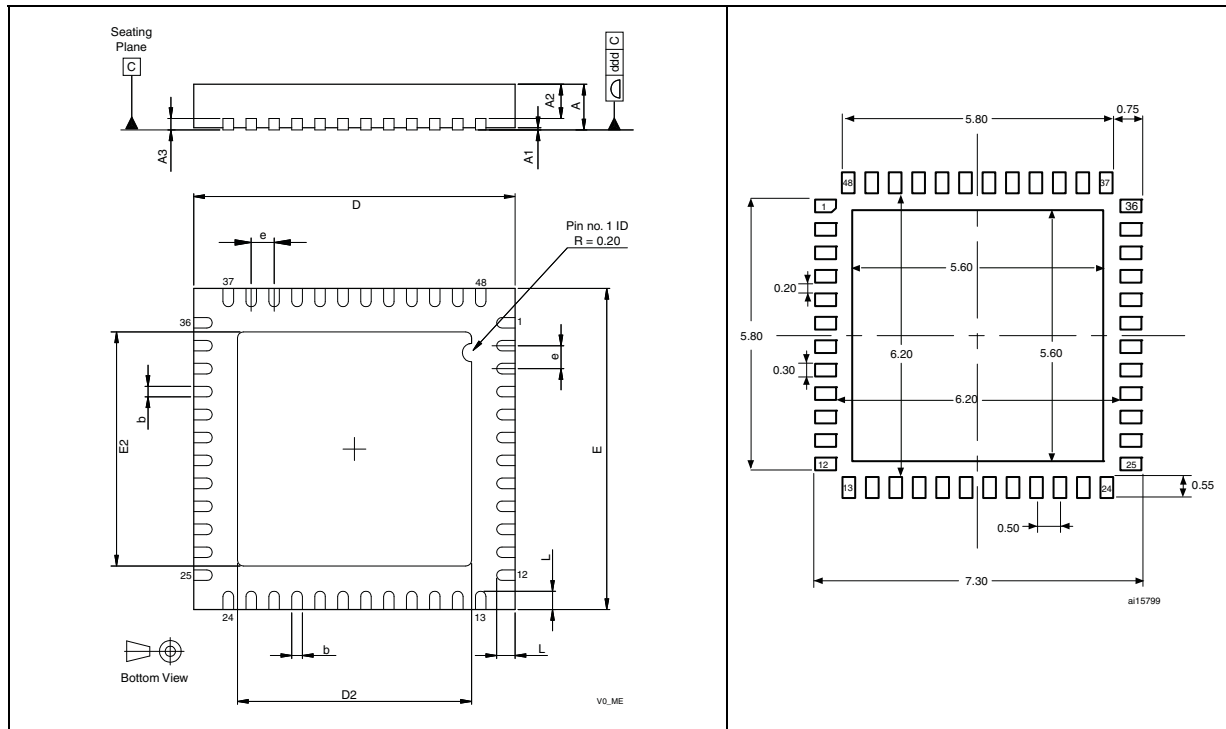

1. Drawing is not to scale.
2. The back-side pad is not internally connected to the  $V_{SS}$  or  $V_{DD}$  power pads.
3. There is an exposed die pad on the underside of the VFQFPN package. It should be soldered to the PCB. All leads should also be soldered to the PCB. It is recommended to connect it to  $V_{SS}$ .

**Table 46. VFQFPN48 7 x 7 mm, 0.5 mm pitch, package mechanical data**

Symbol	millimeters			inches <sup>(1)</sup>		
	Min	Typ	Max	Min	Typ	Max
A	0.800	0.900	1.000	0.0315	0.0354	0.0394
A1		0.020	0.050		0.0008	0.0020
A2		0.650	1.000		0.0256	0.0394
A3		0.250			0.0098	
b	0.180	0.230	0.300	0.0071	0.0091	0.0118
D	6.850	7.000	7.150	0.2697	0.2756	0.2815
D2	2.250	4.700	5.250	0.0886	0.1850	0.2067
E	6.850	7.000	7.150	0.2697	0.2756	0.2815
E2	2.250	4.700	5.250	0.0886	0.1850	0.2067
e	0.450	0.500	0.550	0.0177	0.0197	0.0217
L	0.300	0.400	0.500	0.0118	0.0157	0.0197
ddd		0.080			0.0031	

1. Values in inches are converted from mm and rounded to 4 decimal digits.

Figure 37. VFQFPN36 6 x 6 mm, 0.5 mm pitch, package outline<sup>(1)</sup> Figure 38. Recommended footprint (dimensions in mm)<sup>(1)(2)(3)</sup>

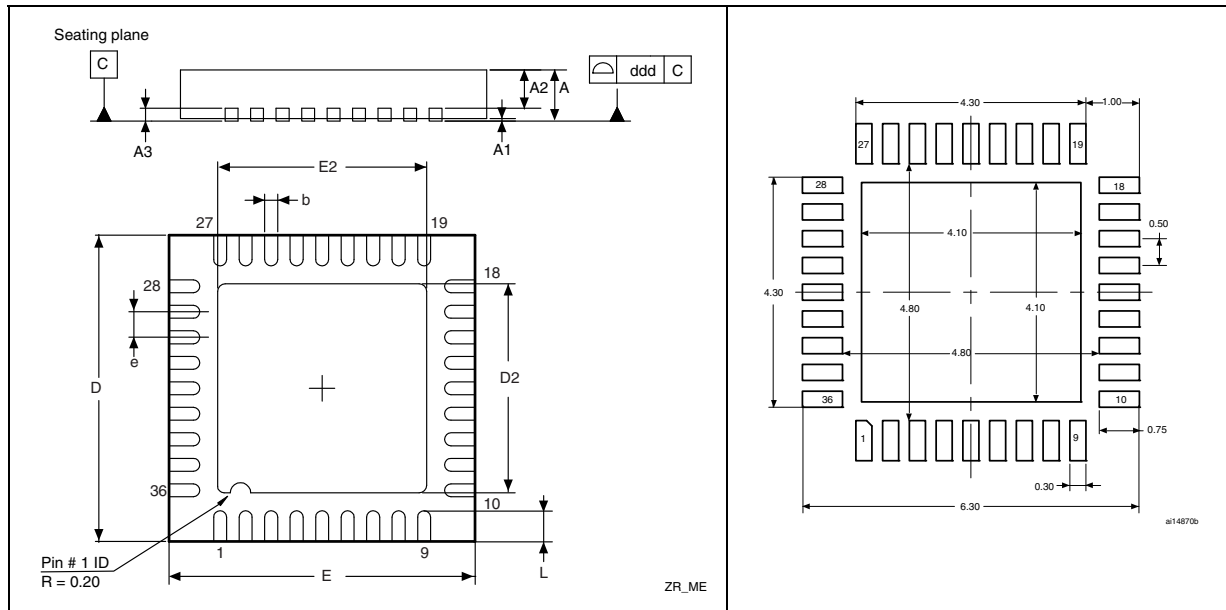

1. Drawing is not to scale.
2. The back-side pad is not internally connected to the V<sub>SS</sub> or V<sub>DD</sub> power pads.
3. There is an exposed die pad on the underside of the VFQFPN package. It should be soldered to the PCB. All leads should also be soldered to the PCB.

Table 47. VFQFPN36 6 x 6 mm, 0.5 mm pitch, package mechanical data

Symbol	millimeters			inches <sup>(1)</sup>		
	Min	Typ	Max	Min	Typ	Max
A	0.800	0.900	1.000	0.0315	0.0354	0.0394
A1		0.020	0.050		0.0008	0.0020
A2		0.650	1.000		0.0256	0.0394
A3		0.250			0.0098	
b	0.180	0.230	0.300	0.0071	0.0091	0.0118
D	5.875	6.000	6.125	0.2313	0.2362	0.2411
D2	1.750	3.700	4.250	0.0689	0.1457	0.1673
E	5.875	6.000	6.125	0.2313	0.2362	0.2411
E2	1.750	3.700	4.250	0.0689	0.1457	0.1673
e	0.450	0.500	0.550	0.0177	0.0197	0.0217
L	0.350	0.550	0.750	0.0138	0.0217	0.0295
ddd		0.080			0.0031	

1. Values in inches are converted from mm and rounded to 4 decimal digits.



Figure 41. LQFP48 – 7 x 7mm, 48-pin low-profile quad flat package outline<sup>(1)</sup>

Figure 42. Recommended footprint<sup>(1)(2)</sup>

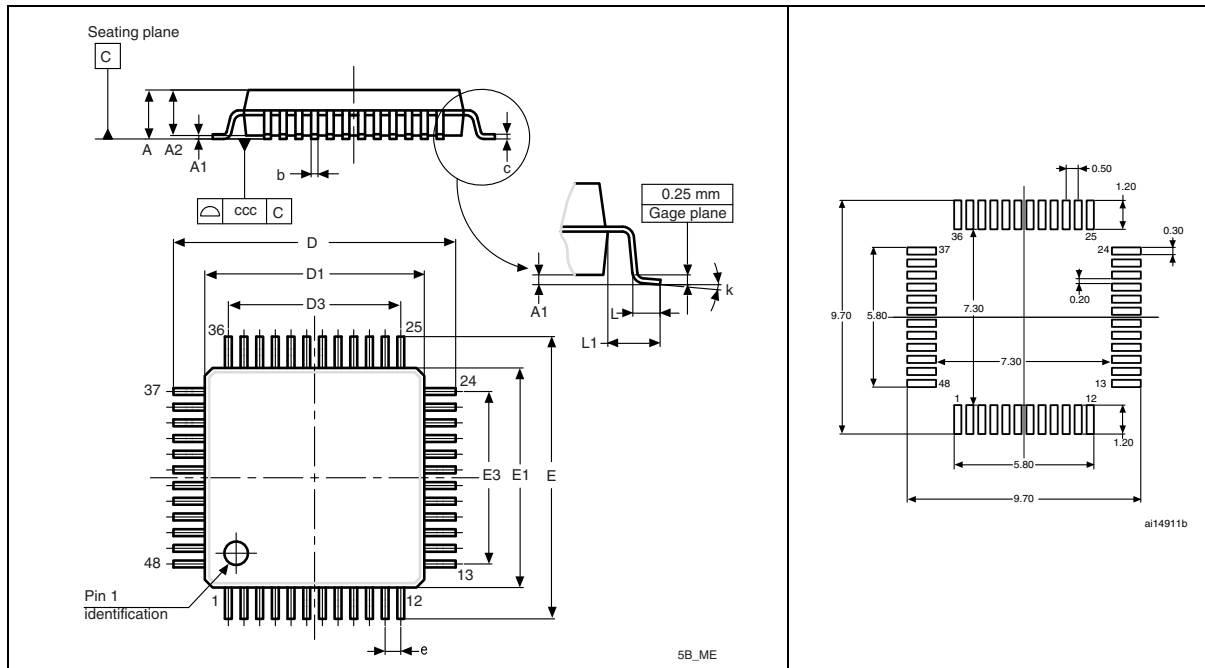

1. Drawing is not to scale.
2. Dimensions are in millimeters.

Table 49. LQFP48 – 7 x 7mm, 48-pin low-profile quad flat package mechanical data

Symbol	millimeters			inches <sup>(1)</sup>		
	Min	Typ	Max	Min	Typ	Max
A			1.600			0.0630
A1	0.050		0.150	0.0020		0.0059
A2	1.350	1.400	1.450	0.0531	0.0551	0.0571
b	0.170	0.220	0.270	0.0067	0.0087	0.0106
c	0.090		0.200	0.0035		0.0079
D	8.800	9.000	9.200	0.3465	0.3543	0.3622
D1	6.800	7.000	7.200	0.2677	0.2756	0.2835
D3		5.500			0.2165	
E	8.800	9.000	9.200	0.3465	0.3543	0.3622
E1	6.800	7.000	7.200	0.2677	0.2756	0.2835
E3		5.500			0.2165	
e		0.500			0.0197	
L	0.450	0.600	0.750	0.0177	0.0236	0.0295
L1		1.000			0.0394	
k	0°	3.5°	7°	0°	3.5°	7°
ccc	0.080			0.0031		

1. Values in inches are converted from mm and rounded to 4 decimal digits.

## 6.2 Thermal characteristics

The maximum chip junction temperature ( $T_{Jmax}$ ) must never exceed the values given in [Table 8: General operating conditions on page 30](#).

The maximum chip-junction temperature,  $T_J$  max, in degrees Celsius, may be calculated using the following equation:

$$T_J \text{ max} = T_A \text{ max} + (P_D \text{ max} \times \Theta_{JA})$$

Where:

- $T_A$  max is the maximum ambient temperature in °C,
- $\Theta_{JA}$  is the package junction-to-ambient thermal resistance, in °C/W,
- $P_D$  max is the sum of  $P_{INT}$  max and  $P_{I/O}$  max ( $P_D$  max =  $P_{INT}$  max +  $P_{I/O}$ max),
- $P_{INT}$  max is the product of  $I_{DD}$  and  $V_{DD}$ , expressed in Watts. This is the maximum chip internal power.

$P_{I/O}$  max represents the maximum power dissipation on output pins where:

$$P_{I/O} \text{ max} = \Sigma (V_{OL} \times I_{OL}) + \Sigma ((V_{DD} - V_{OH}) \times I_{OH}),$$

taking into account the actual  $V_{OL} / I_{OL}$  and  $V_{OH} / I_{OH}$  of the I/Os at low and high level in the application.

**Table 50. Package thermal characteristics**

Symbol	Parameter	Value	Unit
$\Theta_{JA}$	Thermal resistance junction-ambient LQFP 64 - 10 x 10 mm / 0.5 mm pitch	45	°C/W
	Thermal resistance junction-ambient LQFP 48 - 7 x 7 mm / 0.5 mm pitch	55	
	Thermal resistance junction-ambient VFQFPN 48 - 7 x 7 mm / 0.5 mm pitch	16	
	Thermal resistance junction-ambient VFQFPN 36 - 6 x 6 mm / 0.5 mm pitch	18	

### 6.2.1 Reference document

JESD51-2 Integrated Circuits Thermal Test Method Environment Conditions - Natural Convection (Still Air). Available from [www.jedec.org](http://www.jedec.org).

### 6.2.2 Evaluating the maximum junction temperature for an application

When ordering the microcontroller, the temperature range is specified in the ordering information scheme shown in [Table 51: Ordering information scheme](#).

Each temperature range suffix corresponds to a specific guaranteed ambient temperature at maximum dissipation and, to a specific maximum junction temperature. Here, only temperature range 6 is available (−40 to 85 °C).

The following example shows how to calculate the temperature range needed for a given application, making it possible to check whether the required temperature range is compatible with the STM32F101xx junction temperature range.

#### Example: high-performance application

Assuming the following application conditions:

Maximum ambient temperature  $T_{Amax} = 82\text{ °C}$  (measured according to JESD51-2),  
 $I_{DDmax} = 50\text{ mA}$ ,  $V_{DD} = 3.5\text{ V}$ , maximum 20 I/Os used at the same time in output at low level with  $I_{OL} = 8\text{ mA}$ ,  $V_{OL} = 0.4\text{ V}$  and maximum 8 I/Os used at the same time in output mode at low level with  $I_{OL} = 20\text{ mA}$ ,  $V_{OL} = 1.3\text{ V}$

$$P_{INTmax} = 50\text{ mA} \times 3.5\text{ V} = 175\text{ mW}$$

$$P_{IOmax} = 20 \times 8\text{ mA} \times 0.4\text{ V} + 8 \times 20\text{ mA} \times 1.3\text{ V} = 272\text{ mW}$$

This gives:  $P_{INTmax} = 175\text{ mW}$  and  $P_{IOmax} = 272\text{ mW}$

$$P_{Dmax} = 175 + 272 = 447\text{ mW}$$

Thus:  $P_{Dmax} = 447\text{ mW}$

Using the values obtained in [Table 50](#)  $T_{Jmax}$  is calculated as follows:

– For LQFP64, 45 °C/W

$$T_{Jmax} = 82\text{ °C} + (45\text{ °C/W} \times 447\text{ mW}) = 82\text{ °C} + 20.1\text{ °C} = 102.1\text{ °C}$$

This is within the junction temperature range of the STM32F101xx (−40 <  $T_J$  < 105 °C).

**Figure 43. LQFP64  $P_D$  max vs.  $T_A$**

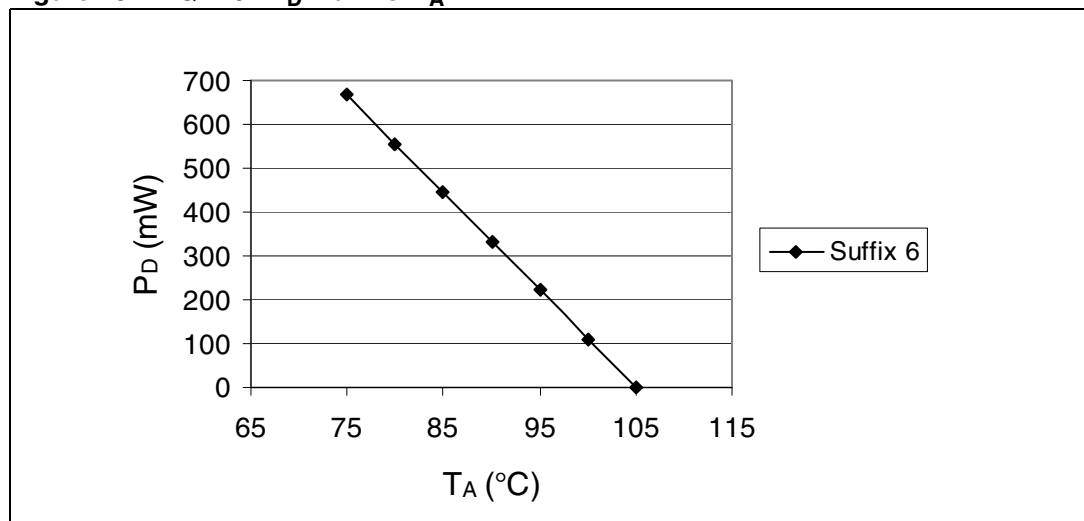

# 7 Ordering information scheme

**Table 51. Ordering information scheme**

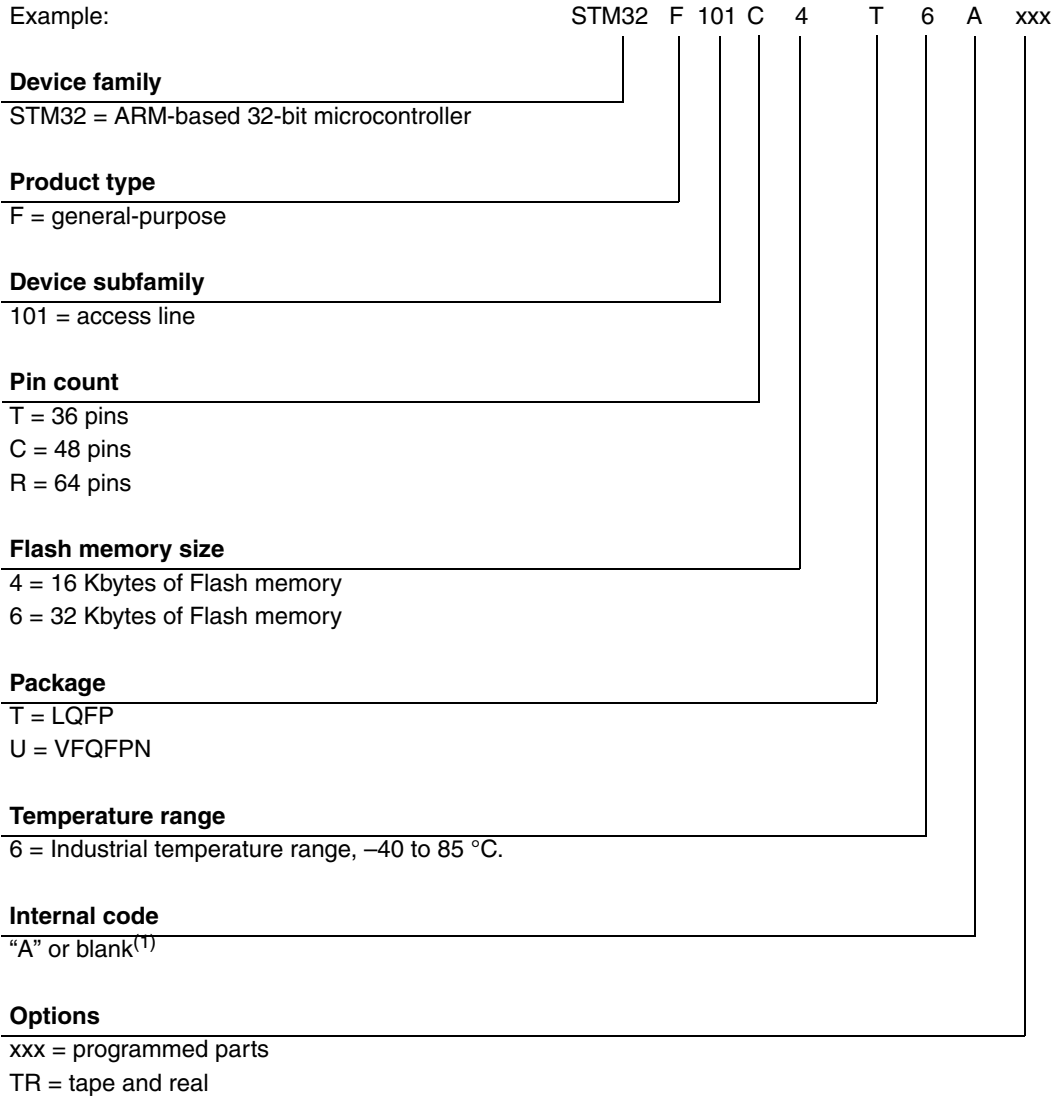

1. For STM32F101x6 devices with a **blank** internal code, please refer to the STM32F103x6/8/B datasheet available from the ST website: [www.st.com](http://www.st.com).

For a list of available options (speed, package, etc.) or for further information on any aspect of this device, please contact your nearest ST sales office.

## 8 Revision history

**Table 52. Document revision history**

Date	Revision	Changes
23-Sep-2008	1	Initial release.
07-Apr-2009	2	<p>I/O information clarified <i>on page 1</i>. <i>Figure 7: Memory map</i> modified.</p> <p>In <i>Table 4: Low-density STM32F101xx pin definitions</i>: PB4, PB13, PB14, PB15, PB3/TRACESWO moved from Default column to Remap column.</p> <p><math>V_{REF-}</math> is not available in the offered packages: <i>Figure 1: STM32F101xx Low-density access line block diagram</i>, <i>Figure 10: Power supply scheme</i> and <i>Figure 34: Power supply and reference decoupling</i> updated, <i>Figure 30: Power supply and reference decoupling (<math>V_{REF+}</math> not connected to <math>V_{DDA}</math>)</i> removed.</p> <p>Note modified in <i>Table 12: Maximum current consumption in Run mode, code with data processing running from Flash</i> and <i>Table 14: Maximum current consumption in Sleep mode, code running from Flash or RAM</i>. <i>Figure 15</i>, <i>Figure 16</i> and <i>Figure 17</i> show typical curves.</p> <p><math>ACC_{HSI}</math> max values modified in <i>Table 23: HSI oscillator characteristics</i>.</p> <p>Small text changes.</p>
24-Sep-2009	3	<p><i>Note 5</i> updated and <i>Note 4</i> added in <i>Table 4: Low-density STM32F101xx pin definitions</i>.</p> <p><math>V_{RERINT}</math> and <math>T_{C_{eff}}</math> added to <i>Table 11: Embedded internal reference voltage</i>. Typical <math>I_{DD\_VBAT}</math> value added in <i>Table 15: Typical and maximum current consumptions in Stop and Standby modes</i>. <i>Figure 14: Typical current consumption on VBAT with RTC on versus temperature at different VBAT values</i> added.</p> <p><math>f_{HSE\_ext}</math> min modified in <i>Table 19: High-speed external user clock characteristics</i>.</p> <p><math>C_{L1}</math> and <math>C_{L2}</math> replaced by C in <i>Table 21: HSE 4-16 MHz oscillator characteristics</i> and <i>Table 22: LSE oscillator characteristics (<math>f_{LSE} = 32.768</math> kHz)</i>, notes modified and moved below the tables.</p> <p><i>Note 1</i> modified below <i>Figure 20: Typical application with an 8 MHz crystal</i>.</p> <p><i>Table 23: HSI oscillator characteristics</i> modified. Conditions removed from <i>Table 25: Low-power mode wakeup timings</i>.</p> <p><i>Figure 27: Recommended NRST pin protection</i> modified.</p> <p>IEC 1000 standard updated to IEC 61000 and SAE J1752/3 updated to IEC 61967-2 in <i>Section 5.3.10: EMC characteristics on page 48</i>.</p> <p>Jitter added to <i>Table 26: PLL characteristics</i>.</p> <p><math>C_{ADC}</math> and <math>R_{AIN}</math> parameters modified in <i>Table 41: ADC characteristics</i>.</p> <p><math>R_{AIN}</math> max values modified in <i>Table 42: RAIN max for <math>f_{ADC} = 14</math> MHz</i>.</p> <p>Small text changes.</p>
20-May-2010	4	<p>Added VFQFPN48 package.</p> <p>Updated note 2 below <i>Table 38: I2C characteristics</i></p> <p>Updated <i>Figure 28: I2C bus AC waveforms and measurement circuit(1)</i></p> <p>Updated <i>Figure 27: Recommended NRST pin protection</i></p> <p>Updated <i>Section 5.3.12: I/O port characteristics</i></p>

**Please Read Carefully:**

Information in this document is provided solely in connection with ST products. STMicroelectronics NV and its subsidiaries ("ST") reserve the right to make changes, corrections, modifications or improvements, to this document, and the products and services described herein at any time, without notice.

All ST products are sold pursuant to ST's terms and conditions of sale.

Purchasers are solely responsible for the choice, selection and use of the ST products and services described herein, and ST assumes no liability whatsoever relating to the choice, selection or use of the ST products and services described herein.

No license, express or implied, by estoppel or otherwise, to any intellectual property rights is granted under this document. If any part of this document refers to any third party products or services it shall not be deemed a license grant by ST for the use of such third party products or services, or any intellectual property contained therein or considered as a warranty covering the use in any manner whatsoever of such third party products or services or any intellectual property contained therein.

**UNLESS OTHERWISE SET FORTH IN ST'S TERMS AND CONDITIONS OF SALE ST DISCLAIMS ANY EXPRESS OR IMPLIED WARRANTY WITH RESPECT TO THE USE AND/OR SALE OF ST PRODUCTS INCLUDING WITHOUT LIMITATION IMPLIED WARRANTIES OF MERCHANTABILITY, FITNESS FOR A PARTICULAR PURPOSE (AND THEIR EQUIVALENTS UNDER THE LAWS OF ANY JURISDICTION), OR INFRINGEMENT OF ANY PATENT, COPYRIGHT OR OTHER INTELLECTUAL PROPERTY RIGHT.**

**UNLESS EXPRESSLY APPROVED IN WRITING BY AN AUTHORIZED ST REPRESENTATIVE, ST PRODUCTS ARE NOT RECOMMENDED, AUTHORIZED OR WARRANTED FOR USE IN MILITARY, AIR CRAFT, SPACE, LIFE SAVING, OR LIFE SUSTAINING APPLICATIONS, NOR IN PRODUCTS OR SYSTEMS WHERE FAILURE OR MALFUNCTION MAY RESULT IN PERSONAL INJURY, DEATH, OR SEVERE PROPERTY OR ENVIRONMENTAL DAMAGE. ST PRODUCTS WHICH ARE NOT SPECIFIED AS "AUTOMOTIVE GRADE" MAY ONLY BE USED IN AUTOMOTIVE APPLICATIONS AT USER'S OWN RISK.**

Resale of ST products with provisions different from the statements and/or technical features set forth in this document shall immediately void any warranty granted by ST for the ST product or service described herein and shall not create or extend in any manner whatsoever, any liability of ST.

ST and the ST logo are trademarks or registered trademarks of ST in various countries.

Information in this document supersedes and replaces all information previously supplied.

The ST logo is a registered trademark of STMicroelectronics. All other names are the property of their respective owners.

© 2010 STMicroelectronics - All rights reserved

STMicroelectronics group of companies

Australia - Belgium - Brazil - Canada - China - Czech Republic - Finland - France - Germany - Hong Kong - India - Israel - Italy - Japan - Malaysia - Malta - Morocco - Philippines - Singapore - Spain - Sweden - Switzerland - United Kingdom - United States of America

[www.st.com](http://www.st.com)