



5781, 5782, 5783, 5784, 5785 Snap on cooler heat sink



Snap on cooler features easy no tools installation. Folded back fins provide maximum surface area while preserving valuable board space.

ORDERING INFORMATION

Part Number	"A" Dim
578105B00000G	3.96 (0.156)
578205B00000G	6.35 (0.250)
578305B00000G	12.70 (0.500)
578405B00000G	19.05 (0.750)
578505B00000G	25.40 (1.000)

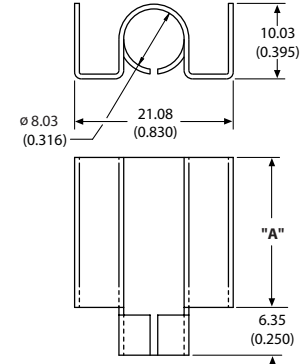
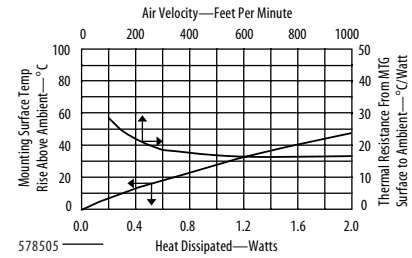
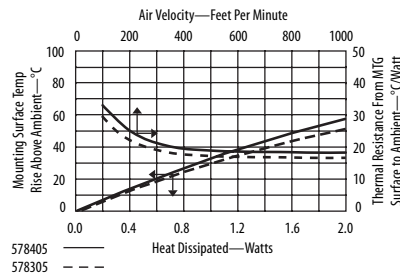
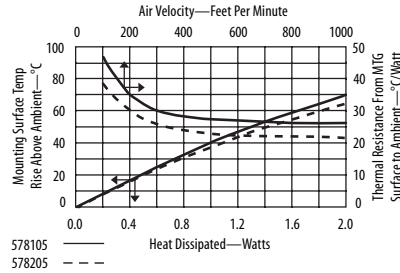

Material: 0.63 (0.025) Thick Aluminum
Finish: Black Anodize

6201, 6202, 6203 Space saving expandable heat sink



Space saving expandable heat sink features a collar that tightly grips the device meaning no extra hardware is required. Heat sinks are constructed of pre-black anodize material to lower cost.

ORDERING INFORMATION

Part Number	"A" Dim	# Fins
6201PBG	6.35 (0.250)	1
6202PBG	12.70 (0.500)	2
6203PBG	19.56 (0.770)	3

* Edges cut during the manufacturing process will be unfinished. See page 110 more more information

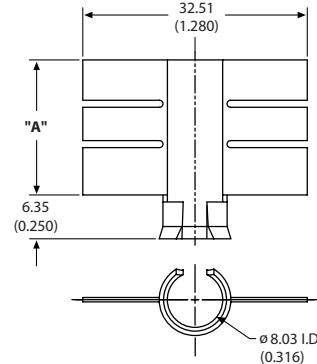
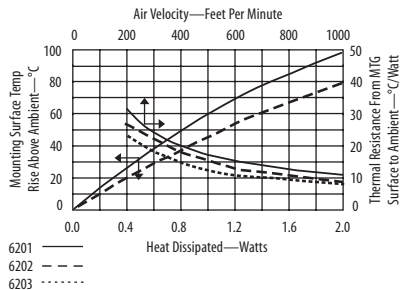

Material: 0.63 (0.025) Thick Aluminum
Finish: Pre Black Anodize*

5F Low cost push on heat sink



Low cost push on heat sink uses spring pressure to firmly grip the device case creating a good thermal interface.

ORDERING INFORMATION

Part Number	Description
5FG	Low cost push on heat sink

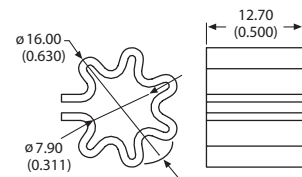
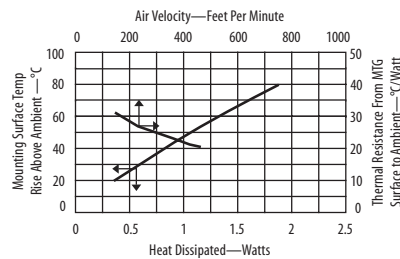

Material: Aluminum
Finish: Black Anodize