

# R-RBL Rawlbolt - Loose Bolt

World's most popular all-purpose expanding shield anchor - loose bolt version



## Approvals and Reports

- ETA-11/0479



## Product information

### Features and benefits

- Shield anchor (shield also available separately)
- Bolt lengths suitable for fixture thickness up to 150mm
- Ferrule marked with hole diameter to ensure correct installation
- Optimum taper nut angle for optimum expansion in all recommended substrates

### Applications

- Roller shutter doors
- Fire doors
- Steelwork
- Security grills
- Machinery
- Pipework/ductwork supports

### Base materials

#### Approved for use in:

- Cracked concrete C20/25-C50/60
- Non-cracked concrete C20/25-C50/60
- Concrete

#### Also suitable for use in:

- Natural Stone
- Hollow-core Slab
- Hollow Brick

## Installation guide



1. Drill a hole of required diameter and depth. Note: When fixing into brickwork, mortar joints should be avoided
2. Remove debris and thoroughly clean hole with brush and pump
3. Remove pre-assembled bolt and washer. Insert shield into hole and tap home with hammer until flush with surface
4. Insert bolt with washer through fixture into the shield
5. Tighten to the recommended torque

**Product information**

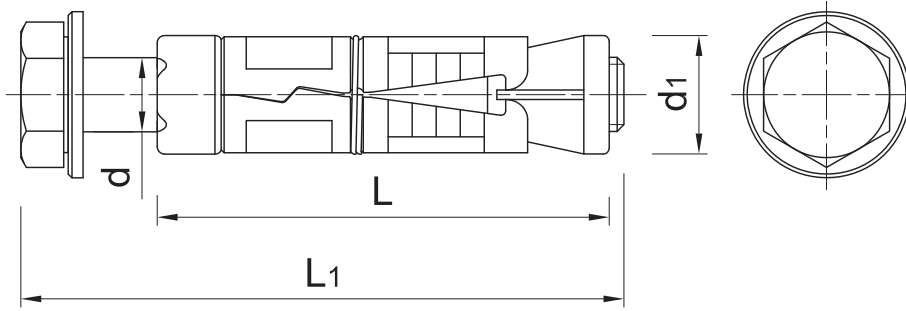

Size	Product Code	Anchor			Fixture		
		Diameter	External diameter	Length	Max. thickness	Min. thickness	Hole diameter
		$d$	$d_1$	$L$	$t_{fix}$		$d_f$
		[mm]	[mm]	[mm]	[mm]	[mm]	[mm]
M6	R-RBL-M06/10W	6	12	55	10	0	6.5
	R-RBL-M06/25W	6	12	70	25	0	6.5
	R-RBL-M06/40W	6	12	85	40	0	6.5
M8	R-RBL-M08/10W	8	14	65	10	0	9
	R-RBL-M08/25W	8	14	80	25	0	9
	R-RBL-M08/40W	8	14	95	40	0	9
M10	R-RBL-M10/10W	10	16	75	10	0	11
	R-RBL-M10/25W	10	16	90	25	0	11
	R-RBL-M10/50W	10	16	115	50	0	11
	R-RBL-M10/75W	10	16	140	75	0	11
M12	R-RBL-M12/10W	12	20	90	10	0	13
	R-RBL-M12/25W	12	20	105	25	0	13
	R-RBL-M12/40W	12	20	120	40	0	13
	R-RBL-M12/60W	12	20	140	60	0	13
M16	R-RBL-M16/15W	16	25	135	15	0	17
	R-RBL-M16/30W	16	25	150	30	10	17
	R-RBL-M16/60W	16	25	180	60	30	17
M20	R-RBL-M20/60W	20	32	195	60	25	22
	R-RBL-M20/100W	20	32	235	110	60	22
M24	R-RBL-M24/100W	24	38	255	100	25	26
	R-RBL-M24/150W	24	38	300	150	100	26

**Installation data**

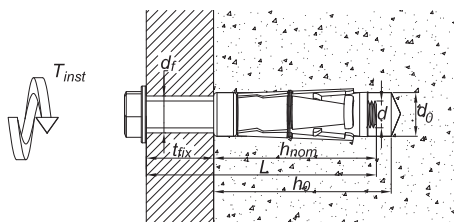

Size		M6	M8	M10	M12	M16	M20	M24
Thread diameter	$d$ [mm]	6	8	10	12	16	20	24
Hole diameter in substrate	$d_0$ [mm]	12	14	16	20	25	32	38
Installation torque	$T_{inst}$ [Nm]	6.5	15	27	50	120	230	400
Min. hole depth in substrate	$h_0$ [mm]	50	55	65	85	125	140	160
Installation depth	$h_{nom}$ [mm]	45	50	60	80	120	135	155
Min. substrate thickness	$h_{min}$ [mm]	100				142.5	172.5	240
Min. spacing	$s_{min}$ [mm]	35	40	50	60	95	115	210
Min. edge distance	$c_{min}$ [mm]	53	60	75	90	143	173	188

## Mechanical properties

Size			M6	M8	M10	M12	M16	M20	M24
Nominal ultimate tensile strength - tension	$f_{uk}$	[N/mm <sup>2</sup> ]	500	500	500	500	500	500	500
Nominal yield strength - tension	$f_{yk}$	[N/mm <sup>2</sup> ]	400	400	400	400	400	400	400
Cross sectional area - tension	$A_s$	[mm <sup>2</sup> ]	20.1	36.6	58	84.3	157	245	353
Elastic section modulus	$W_{el}$	[mm <sup>3</sup> ]	12.7	31.2	62.3	109.2	277.5	540.9	935.5
Characteristic bending resistance	$M_{Rk,s}^0$	[Nm]	7.6	19	37	66	166	325	561
Design bending resistance	M	[Nm]	6.1	15	30	52	133	260	449

## Basic performance data

Performance data for single anchor without influence of edge distance and spacing

Size		M6	M8	M10	M12	M16	M20	M24
<b>NON-CRACKED CONCRETE</b>								
Embedment depth $h_{ef}$	[mm]	35.0	40.0	50.0	60.0	95.0	115.0	125.0
<b>CRACKED CONCRETE</b>								
Embedment depth $h_{ef}$	[mm]	35.0	40.0	50.0	60.0	95.0	115.0	-
<b>MEAN ULTIMATE LOAD</b>								
<b>TENSION LOAD <math>N_{Ru,m}</math></b>								
NON-CRACKED CONCRETE	[kN]	6.36	8.35	15.2	18.5	48.8	56.6	94.3
CRACKED CONCRETE	[kN]	4.06	5.31	7.12	12.0	18.2	34.2	-
<b>SHEAR LOAD <math>V_{Ru,m}</math></b>								
NON-CRACKED CONCRETE	[kN]	6.04	11.0	17.4	25.3	47.1	73.5	105.9
CRACKED CONCRETE	[kN]	6.04	11.0	17.4	25.3	47.1	73.5	-
<b>CHARACTERISTIC LOAD</b>								
<b>TENSION LOAD <math>N_{Rk}</math></b>								
NON-CRACKED CONCRETE	[kN]	6.00	7.50	12.0	16.0	40.0	50.0	70.0
CRACKED CONCRETE	[kN]	4.00	5.00	6.00	12.0	16.0	30.0	-
<b>SHEAR LOAD <math>V_{Rk}</math></b>								
NON-CRACKED CONCRETE	[kN]	5.03	7.50	12.0	21.1	39.3	61.3	88.3
CRACKED CONCRETE	[kN]	4.00	5.00	6.00	21.1	32.0	60.0	-
<b>DESIGN LOAD</b>								
<b>TENSION LOAD <math>N_{Rd}</math></b>								
NON-CRACKED CONCRETE	[kN]	3.33	4.17	6.67	8.89	22.2	27.8	38.9
CRACKED CONCRETE	[kN]	2.22	2.78	3.33	6.67	8.89	16.7	-
<b>SHEAR LOAD <math>V_{Rd}</math></b>								
NON-CRACKED CONCRETE	[kN]	3.33	4.17	6.67	16.9	31.4	49.0	70.6
CRACKED CONCRETE	[kN]	2.22	2.78	3.33	13.3	17.8	33.3	-
<b>RECOMMENDED LOAD</b>								
<b>TENSION LOAD <math>N_{rec}</math></b>								
NON-CRACKED CONCRETE	[kN]	2.38	2.98	4.76	6.35	15.9	19.8	27.8
CRACKED CONCRETE	[kN]	1.59	1.99	2.38	4.76	6.35	11.9	-
<b>SHEAR LOAD <math>V_{rec}</math></b>								
NON-CRACKED CONCRETE	[kN]	2.38	2.98	4.76	12.1	22.4	35.0	50.4
CRACKED CONCRETE	[kN]	1.59	1.99	2.38	9.52	12.7	23.8	-

## Design performance data

Size			M6	M8	M10	M12	M16	M20	M24
Embedment depth	$h_{ef}$	[mm]	35.0	40.0	50.0	60.0	95.0	115.0	125.0
<b>TENSION LOAD</b>									
<b>STEEL FAILURE</b>									
Characteristic resistance	$N_{Rk,s}$	[kN]	10.1	18.3	29.0	42.2	78.5	122.5	176.5
Design resistance $V_{Ms} = 1.5$	$N_{Rd,s}$	[kN]	6.70	12.2	19.3	28.1	52.3	81.7	117.6
<b>PULL-OUT FAILURE; NON-CRACKED CONCRETE C20/25</b>									
Characteristic resistance	$N_{Rk,p}$	[kN]	6.00	7.50	12.0	16.0	40.0	50.0	70.0
Design resistance $V_{Mp} = 1.8$	$N_{Rd,p}$	[kN]	3.33	4.17	6.67	8.89	22.2	27.8	38.9
<b>PULL-OUT FAILURE; CRACKED CONCRETE C20/25</b>									
Characteristic resistance	$N_{Rk,p}$	[kN]	4.00	5.00	6.00	12.0	16.0	30.0	-
Design resistance $V_{Mp} = 1.8$	$N_{Rd,p}$	[kN]	2.22	2.78	3.33	6.67	8.89	16.7	-
Spacing	$s_{cr,N}$	[mm]	105.0	120.0	150.0	180.0	285.0	345.0	375.0
Edge distance	$c_{cr,N}$	[mm]	53.0	60.0	75.0	90.0	143.0	173.0	188.0
<b>EDGE FAILURE; NON-CRACKED CONCRETE C20/25</b>									
Edge distance	$c_1$	[mm]	53.0	60.0	75.0	90.0	143.0	173.0	-
Characteristic resistance for $c_1$	$V_{Rk,c}$	[kN]	7.38	9.11	13.0	17.7	36.8	50.8	58.9
Design resistance $V_{Mc} = 1.8$	$V_{Rd,c}$	[kN]	4.10	5.06	7.24	9.84	20.4	28.2	32.7
<b>EDGE FAILURE; CRACKED CONCRETE C20/25</b>									
Edge distance	$c_1$	[mm]	53.0	60.0	75.0	90.0	143.0	173.0	188.0
Characteristic resistance for $c_1$	$V_{Rk,c}$	[kN]	5.16	6.46	9.23	12.6	25.9	35.9	-
Design resistance $V_{Mc} = 1.8$	$V_{Rd,c}$	[kN]	2.87	3.59	5.13	6.97	14.4	19.9	-
<b>CONCRETE PRY-OUT FAILURE; NON-CRACKED CONCRETE C20/25</b>									
	$k$	-	1.00	1.00	1.00	2.00	2.00	2.00	2.00
Characteristic resistance	$V_{Rk,cp}$	[kN]	6.00	7.50	12.0	32.0	80.0	100.0	140.0
Design resistance $V_{Mc} = 1.8$	$V_{Rd,cp}$	[kN]	3.33	4.17	6.67	17.8	44.4	55.6	77.8
<b>CONCRETE PRY-OUT FAILURE; CRACKED CONCRETE C20/25</b>									
	$k$	-	1.00	1.00	1.00	2.00	2.00	2.00	2.00
Characteristic resistance	$V_{Rk,cp}$	[kN]	4.00	5.00	6.00	24.0	32.0	60.0	-
Design resistance $V_{Mc} = 1.8$	$V_{Rd,cp}$	[kN]	2.22	2.78	3.33	13.3	17.8	33.3	-
<b>STEEL FAILURE</b>									
Characteristic resistance without lever arm	$V_{Rk,s}$	[kN]	5.03	9.15	14.5	21.1	39.3	61.3	88.3
Design resistance $V_{Ms} = 1.25$	$V_{Rd,s}$	[kN]	4.02	7.32	11.6	16.9	31.4	49.0	70.6

## Design performance data

Reduction / increasing resistance factors for edge distance and spacing

Edge distance (shear)

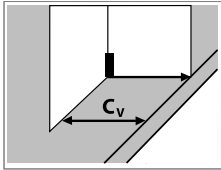

Tables only valid for one edge  $>c_{min}$  and  $s \geq 3c_v$ . For other cases use the Rawlplug Anchor Calculator

Increasing factors for edge distance  $>c_{min}$  applicable to  $V_{Rd,c}$  for non-cracked concrete from 'Design Performance' table

$c_v$ [mm]	M6		M8		M10		M12		M16		M20		M24	
	$h \geq 1.5c_v$	$h_{min}$	$h \geq 1.5c_v$	$h_{min}$	$h \geq 1.5c_v$	$h_{min}$	$h \geq 1.5c_v$	$h_{min}$	$h \geq 1.5c_v$	$h_{min}$	$h \geq 1.5c_v$	$h_{min}$	$h \geq 1.5c_v$	$h_{min}$
55	0,81	0,81												
60			0,82	0,82										
75					0,92	0,92								
90							1,00	0,86						
100							1,15	0,94						
135							1,72	1,21						
145							1,28	1,00	0,82					
160							1,39	1,16	0,89					
175							1,50	1,30	0,96	1,00	0,82			
190							1,61	1,45	1,03	1,13	0,88	1,00	0,82	
200							1,69	1,56	1,07	1,21	0,92	1,09	0,86	
240									1,25	1,53	1,06	1,38	0,99	
265									1,36	1,75	1,15	1,57	1,08	
305									1,53		1,29	1,88	1,21	
350											1,45		1,35	
430											1,73		1,60	
550													1,98	

Edge distance (shear)

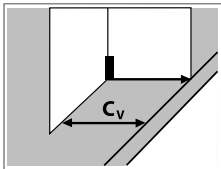

Tables only valid for one edge  $>c_{min}$  and  $s \geq 3c_v$ . For other cases use the Rawlplug Anchor Calculator

Increasing factors for edge distance  $>c_{min}$  applicable to  $V_{Rd,c}$  for cracked concrete from 'Design Performance' table.

$c_v$ [mm]	M6		M8		M10		M12		M16		M20	
	$h \geq 1.5c_v$	$h_{min}$	$h \geq 1.5c_v$	$h_{min}$	$h \geq 1.5c_v$	$h_{min}$	$h \geq 1.5c_v$	$h_{min}$	$h \geq 1.5c_v$	$h_{min}$	$h \geq 1.5c_v$	$h_{min}$
55	0,78	0,78										
60			0,77	0,77								
75					0,65	0,65						
90							1,00	0,86				
100							1,15	0,94				
145							1,89	1,28	1,02	0,83		
165							1,43	1,21	0,92			
175							1,50	1,30	0,96	1,02	0,83	
200							1,69	1,56	1,08	1,21	0,92	
230							1,91	1,75	1,21	1,45	1,03	
255											1,67	1,12
340												1,42
380												1,56
410												1,66

## Design performance data

### Edge distance (tension)

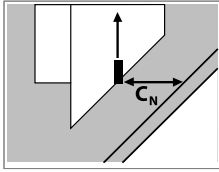

Table only valid for one edge  $<C_{cr,N}$  and  $S \geq S_{cr,N}$ . For other cases use the Rawlplug Anchor Calculator

Reduction factors for edge distance  $<C_{cr,N}$  applicable to  $N_{rd}$  or  $N_{rec}$  for cracked and non-cracked concrete from 'Basic Performance' table

$C_N$ [mm]	M6		M8		M10		M12		M16		M20		M24	
	$h \geq 1.84h_{min}$	$h_{min}$	$h \geq 1.84h_{min}$	$h_{min}$	$h \geq 1.84h_{min}$	$h_{min}$	$h \geq 1.84h_{min}$	$h_{min}$	$h \geq 1.84h_{min}$	$h_{min}$	$h \geq 1.84h_{min}$	$h_{min}$	$h \geq 1.84h_{min}$	$h_{min}$
55	1,0	1,0												
60			1,0	1,0										
75					1,0	1,0								
90							1,0	1,0						
145									1,0	1,0				
175											1,0	1,0		
190													1,0	1,0

### Spacing

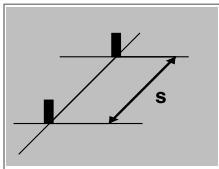

Table only valid for one spacing  $<S_{cr,N}$  and  $c \geq c_{cr,N}$ . For other cases use the Rawlplug Anchor Calculator

Reduction factors for spacing  $<S_{cr,N}$  applicable to  $N_{rd}/V_{rd}$  or  $N_{rec}/V_{rec}$  for non-cracked concrete from 'Basic Performance' table

s [mm]	M6		M8		M10		M12		M16		M20		M24	
	$h \geq 1.84h_{min}$	$h_{min}$	$h \geq 1.84h_{min}$	$h_{min}$	$h \geq 1.84h_{min}$	$h_{min}$	$h \geq 1.84h_{min}$	$h_{min}$	$h \geq 1.84h_{min}$	$h_{min}$	$h \geq 1.84h_{min}$	$h_{min}$	$h \geq 1.84h_{min}$	$h_{min}$
35	0,67	0,67												
40	0,69	0,69	0,67	0,67										
50	0,74	0,74	0,71	0,71	0,67	0,67								
60	0,79	0,79	0,75	0,75	0,70	0,70	0,67	0,67						
80	0,88	0,88	0,83	0,83	0,77	0,77	0,72	0,72						
95	0,95	0,95	0,90	0,90	0,82	0,82	0,76	0,76	0,67	0,67				
100	0,98	0,98	0,92	0,92	0,83	0,83	0,78	0,78	0,68	0,68				
105	1,00	1,00	0,94	0,94	0,85	0,85	0,79	0,79	0,68	0,68				
115			0,98	0,98	0,88	0,88	0,82	0,82	0,70	0,70	0,67	0,67		
120			1,00	1,00	0,90	0,90	0,83	0,83	0,71	0,71	0,67	0,67		
150					1,00	1,00	0,92	0,92	0,76	0,76	0,72	0,72	0,70	0,70
180							1,00	1,00	0,82	0,82	0,76	0,76	0,74	0,74
200									0,85	0,85	0,79	0,79	0,77	0,77
220									0,89	0,89	0,82	0,82	0,79	0,79
250									0,94	0,94	0,86	0,86	0,83	0,83
285									1,00	1,00	0,91	0,91	0,88	0,88
300											0,93	0,93	0,90	0,90
345											1,00	1,00	0,96	0,96
375													1,00	1,00

## Design performance data

### Spacing

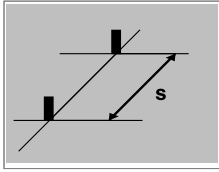

Table only valid for one spacing  $< s_{cr,N}$  and  $c \geq c_{cr,N}$ . For other cases use the Rawlplug Anchor Calculator

Reduction factors for spacing  $< S_{cr,N}$  applicable to  $N_{Rd}/V_{Rd}$  or  $N_{rec}/V_{rec}$  for cracked concrete from 'Basic Performance' table

s [mm]	M6		M8		M10		M12		M16		M20	
	$h \geq 1.84h_{min}$	$h_{min}$	$h \geq 1.84h_{min}$	$h_{min}$	$h \geq 1.84h_{min}$	$h_{min}$	$h \geq 1.84h_{min}$	$h_{min}$	$h \geq 1.84h_{min}$	$h_{min}$	$h \geq 1.84h_{min}$	$h_{min}$
35	0,67	0,67										
40	0,69	0,69	0,67	0,67								
50	0,74	0,74	0,71	0,71	0,67	0,67						
60	0,79	0,79	0,75	0,75	0,70	0,70	0,67	0,67				
80	0,88	0,88	0,83	0,83	0,77	0,77	0,72	0,72				
95	0,95	0,95	0,90	0,90	0,82	0,82	0,76	0,76	0,67	0,67		
100	0,98	0,98	0,92	0,92	0,83	0,83	0,78	0,78	0,68	0,68		
105	1,00	1,00	0,94	0,94	0,85	0,85	0,79	0,79	0,68	0,68		
115			0,98	0,98	0,88	0,88	0,82	0,82	0,70	0,70	0,67	0,67
120			1,00	1,00	0,90	0,90	0,83	0,83	0,71	0,71	0,67	0,67
140					0,97	0,97	0,89	0,89	0,75	0,75	0,70	0,70
150					1,00	1,00	0,92	0,92	0,76	0,76	0,72	0,72
180							1,00	1,00	0,82	0,82	0,76	0,76
200									0,85	0,85	0,79	0,79
285									1,00	1,00	0,91	0,91
300											0,93	0,93
345											1,00	1,00

## Design performance data

Resistance to tension and shear loads under fire exposure

Size			M6	M8	M10	M12	M16	M20
<b>R (for EI) = 30 min</b>								
<b>TENSION LOAD</b>								
<b>STEEL FAILURE</b>								
Characteristic resistance	$N_{Rk,s}$	[kN]	0.20	0.40	0.90	1.70	3.10	4.90
<b>PULL-OUT FAILURE</b>								
Characteristic resistance	$N_{Rk,p}$	[kN]	1.00	1.30	1.50	3.00	4.00	7.50
<b>CONCRETE CONE FAILURE</b>								
Characteristic resistance	$N_{Rk,c}$	[kN]	1.30	1.80	3.20	5.00	15.7	25.4
<b>SHEAR LOAD</b>								
<b>STEEL FAILURE</b>								
Characteristic resistance without lever arm	$V_{Rk,s}$	[kN]	0.20	0.40	0.90	1.70	3.10	4.90
Characteristic resistance with lever arm	$M_{Rk,s}$	[kN]	0.20	0.40	1.10	2.60	6.70	13.0
<b>R (for EI) = 60 min</b>								
<b>TENSION LOAD</b>								
<b>STEEL FAILURE</b>								
Characteristic resistance	$N_{Rk,s}$	[kN]	0.20	0.30	0.80	1.30	2.40	3.70
<b>PULL-OUT FAILURE</b>								
Characteristic resistance	$N_{Rk,p}$	[kN]	1.00	1.30	1.50	3.00	4.00	7.50
<b>CONCRETE CONE FAILURE</b>								
Characteristic resistance	$N_{Rk,c}$	[kN]	1.30	1.80	3.20	5.00	15.7	25.4
<b>SHEAR LOAD</b>								
<b>STEEL FAILURE</b>								
Characteristic resistance without lever arm	$V_{Rk,s}$	[kN]	0.20	0.30	0.80	1.30	2.40	3.70
Characteristic resistance with lever arm	$M_{Rk,s}$	[kN]	0.10	0.30	1.00	2.00	5.00	9.70
<b>R (for EI) = 90 min</b>								
<b>TENSION LOAD</b>								
<b>STEEL FAILURE</b>								
Characteristic resistance	$N_{Rk,s}$	[kN]	0.10	0.30	0.60	1.10	2.00	3.20
<b>PULL-OUT FAILURE</b>								
Characteristic resistance	$N_{Rk,p}$	[kN]	1.00	1.30	1.50	3.00	4.00	7.50
<b>CONCRETE CONE FAILURE</b>								
Characteristic resistance	$N_{Rk,c}$	[kN]	1.30	1.80	3.20	5.00	15.7	25.4
<b>SHEAR LOAD</b>								
<b>STEEL FAILURE</b>								
Characteristic resistance without lever arm	$V_{Rk,s}$	[kN]	0.10	0.30	0.60	1.10	2.00	3.20
Characteristic resistance with lever arm	$M_{Rk,s}$	[kN]	0.10	0.30	0.70	1.70	4.30	8.40
<b>R (for EI) = 120 min</b>								
<b>TENSION LOAD</b>								
<b>STEEL FAILURE</b>								
Characteristic resistance	$N_{Rk,s}$	[kN]	0.10	0.20	0.50	0.80	1.60	2.50
<b>PULL-OUT FAILURE</b>								
Characteristic resistance	$N_{Rk,p}$	[kN]	1.00	1.30	1.50	3.00	4.00	7.50
<b>CONCRETE CONE FAILURE</b>								
Characteristic resistance	$N_{Rk,c}$	[kN]	1.00	1.40	2.50	4.00	12.6	20.3
<b>SHEAR LOAD</b>								
<b>STEEL FAILURE</b>								
Characteristic resistance without lever arm	$V_{Rk,s}$	[kN]	0.10	0.20	0.50	0.80	1.60	2.50
Characteristic resistance with lever arm	$M_{Rk,s}$	[kN]	0.10	0.20	0.60	1.30	3.30	6.50

## Product commercial data

Size	Product Code	Anchor		Quantity [pcs]			Weight [kg]			Bar Codes	Art No.
		Diameter [mm]	Length [mm]	Box	Outer	Pallet	Box	Outer	Pallet		
M6	R-RBL-M06/10W	6	55	50	50	15750	1.55	1.55	518.3	5906675283210	77478
	R-RBL-M06/25W	6	70	50	50	15750	1.60	1.60	534.0	5906675283234	77484
	R-RBL-M06/40W	6	85	50	50	9000	1.85	1.85	363.0	5906675283258	77489
M8	R-RBL-M08/10W	8	65	50	50	15750	2.7	2.7	880.5	5906675283272	77492
	R-RBL-M08/25W	8	80	50	50	9000	3.0	3.0	570.0	5906675283296	77495
	R-RBL-M08/40W	8	95	50	50	9000	3.3	3.3	624.0	5906675283319	77498
M10	R-RBL-M10/10W	10	75	50	50	9000	4.6	4.6	858.0	5906675283333	77500
	R-RBL-M10/25W	10	90	50	50	7500	5.0	5.0	780.0	5906675283357	77503
	R-RBL-M10/50W	10	115	50	50	4500	5.7	5.7	543.0	5906675283371	77516
	R-RBL-M10/75W	10	140	50	50	5400	6.4	6.4	721.2	5906675283395	77523
M12	R-RBL-M12/10W	12	90	25	25	4500	4.3	4.3	808.5	5906675283401	77526
	R-RBL-M12/25W	12	105	25	25	2700	4.6	4.6	521.4	5906675283418	77528
	R-RBL-M12/40W	12	120	25	25	2250	4.6	4.6	441.8	5906675283425	77530
	R-RBL-M12/60W	12	140	25	25	2250	5.2	5.2	500.3	5906675283432	77531
M16	R-RBL-M16/15W	16	135	10	10	900	4.1	4.1	401.7	5906675283449	77533
	R-RBL-M16/30W	16	150	10	10	900	4.4	4.4	421.5	5906675283456	77534
	R-RBL-M16/60W	16	180	10	10	900	4.8	4.8	461.1	5906675283463	77535
M20	R-RBL-M20/60W	20	195	10	10	690	8.8	8.8	634.4	5906675283487	77538
	R-RBL-M20/100W	20	235	10	10	360	9.8	9.8	383.5	5906675283470	77537
M24	R-RBL-M24/100W	24	255	5	5	144	7.3	7.3	238.8	5906675283494	77539
	R-RBL-M24/150W	24	300	2	10	190	3.3	16.3	339.7	5906675283500	77540