

## FXL4TD245

### Low-Voltage Dual-Supply 4-Bit Signal Translator with Configurable Voltage Supplies and Signal Levels and 3-STATE Outputs and Independent Direction Controls

#### Features

- Bi-directional interface between any 2 levels from 1.1V to 3.6V
- Fully configurable: inputs track  $V_{CC}$  level
- Non-preferential power-up sequencing; either  $V_{CC}$  may be powered-up first
- Outputs remain in 3-STATE until active  $V_{CC}$  level is reached
- Outputs switch to 3-STATE if either  $V_{CC}$  is at GND
- Power-off protection
- Control inputs ( $T/\bar{R}_n$ ,  $\overline{OE}$ ) levels are referenced to  $V_{CCA}$  voltage
- Packaged in 16-terminal DQFN (2.5mm x 3.5mm) and 16-terminal MicroMLP (1.8mm x 2.6mm)
- ESD protections exceeds:
  - 4kV HBM ESD (per JESD22-A114 & Mil Std 883e 3015.7)
  - 8kV HBM I/O to GND ESD (per JESD22-A114 & Mil Std 883e 3015.7)
  - 1kV CDM ESD (per ESD STM 5.3)
  - 200V MM ESD (per JESD22-A115 & ESD STM5.2)

#### General Description

The FXL4TD245 is a configurable 4-bit dual-voltage-supply translator designed for both uni-directional and bi-directional voltage translation between two logic levels. The device allows translation between voltages as high as 3.6V to as low as 1.1V. The A port tracks the  $V_{CCA}$  level, and the B port tracks the  $V_{CCB}$  level. This allows for bi-directional voltage translation over a variety of voltage levels: 1.2V, 1.5V, 1.8V, 2.5V, and 3.3V.

The device remains in 3-STATE until both  $V_{CC}$ s reach active levels allowing either  $V_{CC}$  to be powered-up first. Internal power down control circuits place the device in 3-STATE if either  $V_{CC}$  is removed.

The Transmit/Receive ( $T/\bar{R}$ ) inputs independently determine the direction of data through each of the four bits. The  $\overline{OE}$  input, when HIGH, disables both the A and B Ports by placing them in a 3-STATE condition. The FXL4TD245 is designed so that the control pins ( $T/\bar{R}$  and  $\overline{OE}$ ) are supplied by  $V_{CCA}$ .

#### Ordering Information

Order Number	Package Number	 Eco Status	Package Description
FXL4TD245BQX	MLP016E	Green	16-Terminal Depopulated Quad Very-Thin Flat Pack, No Leads (DQFN), JEDEC MO-241, 2.5mm x 3.5mm
FXL4TD245UMX	UMLP16A	Green	16-Terminal Quad, Ultrathin, Molded Leadless Package (UMLP), 1.8mm x 2.6mm, 0.4mm Pitch

 For Fairchild's definition of "green" Eco Status, please visit: [http://www.fairchildsemi.com/company/green/rohs\\_green.html](http://www.fairchildsemi.com/company/green/rohs_green.html).

#### Functional Diagram

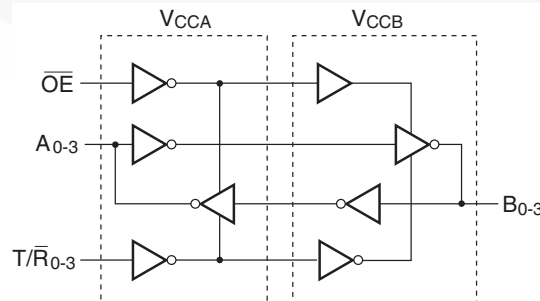

## Connection Diagrams

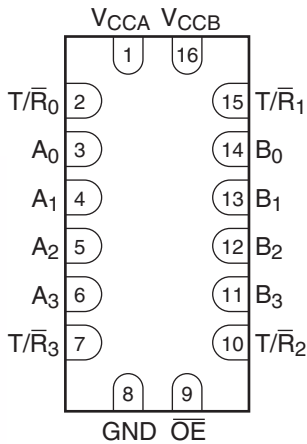

DQFN Pad Assignments (Top Through View)

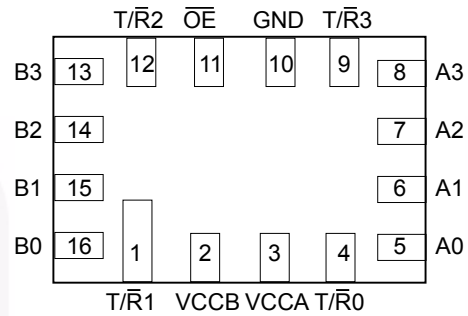

MicroMLP Pad Assignments (Top Through View)

## Top Mark

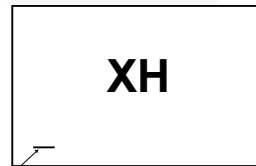

MicroMLP Top Mark (Top View)

## Pin Assignment

DQFN Pin #	$\mu$ MLP Pin #	Terminal Name	Description
1	3	V <sub>CCA</sub>	Side A Power Supply
2	4	T/ $\bar{R}$ <sub>0</sub>	Transmit/Receive Input
3–6	5–8	A <sub>0</sub> –A <sub>3</sub>	Side A Inputs or 3-STATE Outputs
7	9	T/ $\bar{R}$ <sub>3</sub>	Transmit/Receive Input
8	10	GND	Ground
9	11	$\overline{OE}$	Output Enable Input
10	12	T/ $\bar{R}$ <sub>2</sub>	Transmit/Receive Input
11–14	13–16	B <sub>3</sub> –B <sub>0</sub>	Side B Inputs or 3-STATE Outputs
15	1	T/ $\bar{R}$ <sub>1</sub>	Transmit/Receive Input
16	2	V <sub>CCB</sub>	Side B Power Supply

### Truth Table

Inputs					Outputs
$\overline{OE}$	$T/\overline{R}_0$	$T/\overline{R}_1$	$T/\overline{R}_2$	$T/\overline{R}_3$	
L	L	X	X	X	B0 Data to A0 Output
L	H	X	X	X	A0 Data to B0 Output
L	X	L	X	X	B1 Data to A1 Output
L	X	H	X	X	A1 Data to B1 Output
L	X	X	L	X	B2 Data to A2 Output
L	X	X	H	X	A2 Data to B2 Output
L	X	X	X	L	B3 Data to A3 Output
L	X	X	X	H	A3 Data to B3 Output
H	X	X	X	X	3-State

H = HIGH Voltage Level  
L = LOW Voltage Level  
X = Don't Care

### Power-Up/Power-Down Sequencing

FXL translators offer an advantage in that either  $V_{CC}$  may be powered up first. This benefit derives from the chip design. When either  $V_{CC}$  is at 0 volts, outputs are in a HIGH-Impedance state. The control inputs ( $T/\overline{R}_n$  and  $\overline{OE}$ ) are designed to track the  $V_{CCA}$  supply. A pull-up resistor tying  $\overline{OE}$  to  $V_{CCA}$  should be used to ensure that bus contention, excessive currents, or oscillations do not occur during power-up/power-down. The size of the pull-up resistor is based upon the current-sinking capability of the  $\overline{OE}$  driver.

The recommended power-up sequence is the following:

1. Apply power to either  $V_{CC}$ .
2. Apply power to the  $T/\overline{R}_n$  inputs (Logic HIGH for A-to-B operation; Logic LOW for B-to-A operation) and to the respective data inputs (A Port or B Port). This may occur at the same time as Step 1.
3. Apply power to other  $V_{CC}$ .
4. Drive the  $\overline{OE}$  input LOW to enable the device.

The recommended power-down sequence is the following:

1. Drive  $\overline{OE}$  input HIGH to disable the device.
2. Remove power from either  $V_{CC}$ .
3. Remove power from other  $V_{CC}$ .

## Absolute Maximum Ratings

The “Absolute Maximum Ratings” are those values beyond which the safety of the device cannot be guaranteed. The device should not be operated at these limits. The parametric values defined in the Electrical Characteristics tables are not guaranteed at the absolute maximum ratings. The “Recommended Operating Conditions” table will define the conditions for actual device operation.

Symbol	Parameter	Rating
$V_{CCA}, V_{CCB}$	Supply Voltage	-0.5V to +4.6V
$V_I$	DC Input Voltage I/O Port A I/O Port B Control Inputs ( $\overline{T/R}_n, \overline{OE}$ )	-0.5V to +4.6V -0.5V to +4.6V -0.5V to +4.6V
$V_O$	Output Voltage <sup>(1)</sup> Outputs 3-STATE Outputs Active ( $A_n$ ) Outputs Active ( $B_n$ )	-0.5V to +4.6V -0.5V to $V_{CCA} + 0.5V$ -0.5V to $V_{CCB} + 0.5V$
$I_{IK}$	DC Input Diode Current @ $V_I < 0V$	-50mA
$I_{OK}$	DC Output Diode Current @ $V_O < 0V$ $V_O > V_{CC}$	-50mA +50mA
$I_{OH}/I_{OL}$	DC Output Source/Sink Current	-50mA / +50mA
$I_{CC}$	DC $V_{CC}$ or Ground Current per Supply Pin	$\pm 100mA$
$T_{STG}$	Storage Temperature Range	-65°C to +150°C

## Recommended Operating Conditions<sup>(2)</sup>

The Recommended Operating Conditions table defines the conditions for actual device operation. Recommended operating conditions are specified to ensure optimal performance to the datasheet specifications. Fairchild does not recommend exceeding them or designing to Absolute Maximum Ratings.

Symbol	Parameter	Rating
$V_{CCA}$ or $V_{CCB}$	Power Supply Operating	1.1V to 3.6V
	Input Voltage Port A Port B Control Inputs ( $\overline{T/R}_n, \overline{OE}$ )	0.0V to 3.6V 0.0V to 3.6V 0.0V to $V_{CCA}$
	Output Current in $I_{OH}/I_{OL}$ with $V_{CC}$ @ 3.0V to 3.6V 2.3V to 2.7V 1.65V to 1.95V 1.4V to 1.65V 1.1V to 1.4V	$\pm 24mA$ $\pm 18mA$ $\pm 6mA$ $\pm 2mA$ $\pm 0.5mA$
$T_A$	Free Air Operating Temperature	-40°C to +85°C
$\Delta t/\Delta V$	Maximum Input Edge Rate $V_{CCA/B} = 1.1V$ to 3.6V	10ns/V

### Notes:

- $I_O$  Absolute Maximum Rating must be observed.
- All unused inputs and I/O pins must be held at  $V_{CCI}$  or GND.

### DC Electrical Characteristics

Symbol	Parameter	Conditions	V <sub>CCI</sub> (V)	V <sub>CC0</sub> (V)	Min.	Max.	Units
V <sub>IH</sub>	High Level Input Voltage <sup>(3)</sup>	Data Inputs A <sub>n</sub> , B <sub>n</sub>	2.7–3.6	1.1–3.6	2.0		V
			2.3–2.7		1.6		
			1.65–2.3		0.65 x V <sub>CCI</sub>		
			1.4–1.65		0.65 x V <sub>CCI</sub>		
			1.1–1.4		0.9 x V <sub>CCI</sub>		
		Control Pins $\overline{OE}$ , T/ $\overline{R_n}$ (Referenced to V <sub>CCA</sub> )	2.7–3.6	1.1–3.6	2.0		V
			2.3–2.7		1.6		
			1.65–2.3		0.65 x V <sub>CCA</sub>		
			1.4–1.65		0.65 x V <sub>CCA</sub>		
			1.1–1.4		0.9 x V <sub>CCA</sub>		
V <sub>IL</sub>	Low Level Input Voltage <sup>(3)</sup>	Data Inputs A <sub>n</sub> , B <sub>n</sub>	2.7–3.6	1.1–3.6		0.8	V
			2.3–2.7			0.7	
			1.65–2.3			0.35 x V <sub>CCI</sub>	
			1.4–1.65			0.35 x V <sub>CCI</sub>	
			1.1–1.4			0.1 x V <sub>CCI</sub>	
		Control Pins $\overline{OE}$ , T/ $\overline{R_n}$ (Referenced to V <sub>CCA</sub> )	2.7–3.6	1.1–3.6		0.8	V
			2.3–2.7			0.7	
			1.65–2.3			0.35 x V <sub>CCA</sub>	
			1.4–1.65			0.35 x V <sub>CCA</sub>	
			1.1–1.4			0.1 x V <sub>CCA</sub>	
V <sub>OH</sub>	High Level Output Voltage <sup>(4)</sup>	I <sub>OH</sub> = –100μA	1.1–3.6	1.1–3.6	V <sub>CC0</sub> –0.2		V
		I <sub>OH</sub> = –12mA	2.7	2.7	2.2		
		I <sub>OH</sub> = –18mA	3.0	3.0	2.4		
		I <sub>OH</sub> = –24mA	3.0	3.0	2.2		
		I <sub>OH</sub> = –6mA	2.3	2.3	2.0		
		I <sub>OH</sub> = –12mA	2.3	2.3	1.8		
		I <sub>OH</sub> = –18mA	2.3	2.3	1.7		
		I <sub>OH</sub> = –6mA	1.65	1.65	1.25		
		I <sub>OH</sub> = –2mA	1.4	1.4	1.05		
		I <sub>OH</sub> = –0.5mA	1.1	1.1	0.75 x V <sub>CC0</sub>		
V <sub>OL</sub>	Low Level Output Voltage <sup>(4)</sup>	I <sub>OL</sub> = 100μA	1.1–3.6	1.1–3.6		0.2	V
		I <sub>OL</sub> = 12mA	2.7	2.7		0.4	
		I <sub>OL</sub> = 18mA	3.0	3.0		0.4	
		I <sub>OL</sub> = 24mA	3.0	3.0		0.55	
		I <sub>OL</sub> = 12mA	2.3	2.3		0.4	
		I <sub>OL</sub> = 18mA	2.3	2.3		0.6	
		I <sub>OL</sub> = 6mA	1.65	1.65		0.3	
		I <sub>OL</sub> = 2mA	1.4	1.4		0.35	
		I <sub>OL</sub> = 0.5mA	1.1	1.1		0.3 x V <sub>CC0</sub>	

### DC Electrical Characteristics (Continued)

Symbol	Parameter	Conditions	V <sub>CCI</sub> (V)	V <sub>CCO</sub> (V)	Min.	Max.	Units
I <sub>I</sub>	Input Leakage Current. Control Pins	V <sub>I</sub> = V <sub>CCA</sub> or GND	1.1–3.6	3.6		±1.0	μA
I <sub>OFF</sub>	Power Off Leakage Current	A <sub>n</sub> , V <sub>I</sub> or V <sub>O</sub> = 0V to 3.6V	0	3.6		±10.0	μA
		B <sub>n</sub> , V <sub>I</sub> or V <sub>O</sub> = 0V to 3.6V	3.6	0		±10.0	
I <sub>OZ</sub>	3-STATE Output Leakage <sup>(5)</sup> 0 ≤ V <sub>O</sub> ≤ 3.6V V <sub>I</sub> = V <sub>IH</sub> or V <sub>IL</sub>	A <sub>n</sub> , B <sub>n</sub> $\overline{OE} = V_{IH}$	3.6	3.6		±10.0	μA
		B <sub>n</sub> , $\overline{OE} = \text{Don't Care}$	0	3.6		+10.0	
		A <sub>n</sub> , $\overline{OE} = \text{Don't Care}$	3.6	0		+10.0	
I <sub>CCA/B</sub>	Quiescent Supply Current <sup>(6)</sup>	V <sub>I</sub> = V <sub>CCI</sub> or GND; I <sub>O</sub> = 0	1.1–3.6	1.1–3.6		20.0	μA
I <sub>CCZ</sub>	Quiescent Supply Current <sup>(6)</sup>	V <sub>I</sub> = V <sub>CCI</sub> or GND; I <sub>O</sub> = 0	1.1–3.6	1.1–3.6		20.0	μA
I <sub>CCA</sub>	Quiescent Supply Current	V <sub>I</sub> = V <sub>CCA</sub> or GND; I <sub>O</sub> = 0	0	1.1–3.6		-10.0	μA
		V <sub>I</sub> = V <sub>CCA</sub> or GND; I <sub>O</sub> = 0	1.1–3.6	0		10.0	μA
I <sub>CCB</sub>	Quiescent Supply Current	V <sub>I</sub> = V <sub>CCB</sub> or GND; I <sub>O</sub> = 0	1.1–3.6	0		-10.0	μA
		V <sub>I</sub> = V <sub>CCB</sub> or GND; I <sub>O</sub> = 0	0	1.1–3.6		10.0	μA
ΔI <sub>CCA/B</sub>	Increase in I <sub>CC</sub> per Input; Other Inputs at V <sub>CC</sub> or GND	V <sub>IH</sub> = 3.0	3.6	3.6		500	μA

**Notes:**

3. V<sub>CCI</sub> = the V<sub>CC</sub> associated with the data input under test.
4. V<sub>CCO</sub> = the V<sub>CC</sub> associated with the output under test.
5. Don't Care = Any valid logic level.
6. Reflects current per supply, V<sub>CCA</sub> or V<sub>CCB</sub>.

## AC Electrical Characteristics

$V_{CCA} = 3.0V$  to  $3.6V$

Symbol	Parameter	$T_A = -40^\circ C$ to $+85^\circ C$										Units
		$V_{CCB} = 3.0V$ to $3.6V$		$V_{CCB} = 2.3V$ to $2.7V$		$V_{CCB} = 1.65V$ to $1.95V$		$V_{CCB} = 1.4V$ to $1.6V$		$V_{CCB} = 1.1V$ to $1.3V$		
		Min.	Max.	Min.	Max.	Min.	Max.	Min.	Max.	Min.	Max.	
$t_{PLH}, t_{PHL}$	Propagation Delay A to B	0.2	3.5	0.3	3.9	0.5	5.4	0.6	6.8	1.4	22.0	ns
	Propagation Delay B to A	0.2	3.5	0.2	3.8	0.3	4.0	0.5	4.3	0.8	13.0	
$t_{PZH}, t_{PZL}$	Output Enable $\overline{OE}$ to B	0.5	4.0	0.7	4.4	1.0	5.9	1.0	6.4	1.5	17.0	ns
	Output Enable $\overline{OE}$ to A	0.5	4.0	0.5	4.0	0.5	4.0	0.5	4.0	0.5	4.0	
$t_{PHZ}, t_{PLZ}$	Output Disable $\overline{OE}$ to B	0.2	3.8	0.2	4.0	0.7	4.8	1.5	6.2	2.0	17.0	ns
	Output Disable $\overline{OE}$ to A	0.2	3.7	0.2	3.7	0.2	3.7	0.2	3.7	0.2	3.7	

$V_{CCA} = 2.3V$  to  $2.7V$

Symbol	Parameter	$T_A = -40^\circ C$ to $+85^\circ C$										Units
		$V_{CCB} = 3.0V$ to $3.6V$		$V_{CCB} = 2.3V$ to $2.7V$		$V_{CCB} = 1.65V$ to $1.95V$		$V_{CCB} = 1.4V$ to $1.6V$		$V_{CCB} = 1.1V$ to $1.3V$		
		Min.	Max.	Min.	Max.	Min.	Max.	Min.	Max.	Min.	Max.	
$t_{PLH}, t_{PHL}$	Propagation Delay A to B	0.2	3.8	0.4	4.2	0.5	5.6	0.8	6.9	1.4	22.0	ns
	Propagation Delay B to A	0.3	3.9	0.4	4.2	0.5	4.5	0.5	4.8	1.0	7.0	
$t_{PZH}, t_{PZL}$	Output Enable $\overline{OE}$ to B	0.6	4.2	0.8	4.6	1.0	6.0	1.0	6.8	1.5	17.0	ns
	Output Enable $\overline{OE}$ to A	0.6	4.5	0.6	4.5	0.6	4.5	0.6	4.5	0.6	4.5	
$t_{PHZ}, t_{PLZ}$	Output Disable $\overline{OE}$ to B	0.2	4.1	0.2	4.3	0.7	4.8	1.5	6.7	2.0	17.0	ns
	Output Disable $\overline{OE}$ to A	0.2	4.0	0.2	4.0	0.2	4.0	0.2	4.0	0.2	4.0	

$V_{CCA} = 1.65V$  to  $1.95V$

Symbol	Parameter	$T_A = -40^\circ C$ to $+85^\circ C$										Units
		$V_{CCB} = 3.0V$ to $3.6V$		$V_{CCB} = 2.3V$ to $2.7V$		$V_{CCB} = 1.65V$ to $1.95V$		$V_{CCB} = 1.4V$ to $1.6V$		$V_{CCB} = 1.1V$ to $1.3V$		
		Min.	Max.	Min.	Max.	Min.	Max.	Min.	Max.	Min.	Max.	
$t_{PLH}, t_{PHL}$	Propagation Delay A to B	0.3	4.0	0.5	4.5	0.8	5.7	0.9	7.1	1.5	22.0	ns
	Propagation Delay B to A	0.5	5.4	0.5	5.6	0.8	5.7	1.0	6.0	1.2	8.0	
$t_{PZH}, t_{PZL}$	Output Enable $\overline{OE}$ to B	0.6	5.2	0.8	5.4	1.2	6.9	1.2	7.2	1.5	18.0	ns
	Output Enable $\overline{OE}$ to A	1.0	6.7	1.0	6.7	1.0	6.7	1.0	6.7	1.0	6.7	
$t_{PHZ}, t_{PLZ}$	Output Disable $\overline{OE}$ to B	0.2	5.1	0.2	5.2	0.8	5.2	1.5	7.0	2.0	17.0	ns
	Output Disable $\overline{OE}$ to A	0.5	5.0	0.5	5.0	0.5	5.0	0.5	5.0	0.5	5.0	

## AC Electrical Characteristics (Continued)

$V_{CCA} = 1.4V$  to  $1.6V$

Symbol	Parameter	$T_A = -40^{\circ}C$ to $+85^{\circ}C$										Units
		$V_{CCB} = 3.0V$ to $3.6V$		$V_{CCB} = 2.3V$ to $2.7V$		$V_{CCB} = 1.65V$ to $1.95V$		$V_{CCB} = 1.4V$ to $1.6V$		$V_{CCB} = 1.1V$ to $1.3V$		
		Min.	Max.	Min.	Max.	Min.	Max.	Min.	Max.	Min.	Max.	
$t_{PLH}, t_{PHL}$	Propagation Delay A to B	0.5	4.3	0.5	4.8	1.0	6.0	1.0	7.3	1.5	22.0	ns
	Propagation Delay B to A	0.6	6.8	0.8	6.9	0.9	7.1	1.0	7.3	1.3	9.5	
$t_{PZH}, t_{PZL}$	Output Enable $\overline{OE}$ to B	1.1	7.5	1.1	7.6	1.3	7.7	1.4	7.9	2.0	20.0	ns
	Output Enable $\overline{OE}$ to A	1.0	7.5	1.0	7.5	1.0	7.5	1.0	7.5	1.0	7.5	
$t_{PHZ}, t_{PLZ}$	Output Disable $\overline{OE}$ to B	0.4	6.1	0.4	6.2	0.9	6.2	1.5	7.5	2.0	18.0	ns
	Output Disable $\overline{OE}$ to A	1.0	6.0	1.0	6.0	1.0	6.0	1.0	6.0	1.0	6.0	

$V_{CCA} = 1.1V$  to  $1.3V$

Symbol	Parameter	$T_A = -40^{\circ}C$ to $+85^{\circ}C$										Units
		$V_{CCB} = 3.0V$ to $3.6V$		$V_{CCB} = 2.3V$ to $2.7V$		$V_{CCB} = 1.65V$ to $1.95V$		$V_{CCB} = 1.4V$ to $1.6V$		$V_{CCB} = 1.1V$ to $1.3V$		
		Min.	Max.	Min.	Max.	Min.	Max.	Min.	Max.	Min.	Max.	
$t_{PLH}, t_{PHL}$	Propagation Delay A to B	0.8	13.0	1.0	7.0	1.2	8.0	1.3	9.5	2.0	24.0	ns
	Propagation Delay B to A	1.4	22.0	1.4	22.0	1.5	22.0	1.5	22.0	2.0	24.0	
$t_{PZH}, t_{PZL}$	Output Enable $\overline{OE}$ to B	1.0	12.0	1.0	9.0	2.0	10.0	2.0	11.0	2.0	24.0	ns
	Output Enable $\overline{OE}$ to A	2.0	22.0	2.0	22.0	2.0	22.0	2.0	22.0	2.0	22.0	
$t_{PHZ}, t_{PLZ}$	Output Disable $\overline{OE}$ to B	1.0	15.0	0.7	7.0	1.0	8.0	2.0	10.0	2.0	20.0	ns
	Output Disable $\overline{OE}$ to A	2.0	15.0	2.0	12.0	2.0	12.0	2.0	12.0	2.0	12.0	

## Capacitance

Symbol	Parameter	Conditions	$T_A = +25^{\circ}C$	Units
			Typical	
$C_{IN}$	Input Capacitance Control Pins ( $\overline{OE}$ , T/R)	$V_{CCA} = V_{CCB} = 3.3V$ , $V_I = 0V$ or $V_{CCA/B}$	4.0	pF
$C_{I/O}$	Input/Output Capacitance $A_n$ , $B_n$ Ports	$V_{CCA} = V_{CCB} = 3.3V$ , $V_I = 0V$ or $V_{CCA/B}$	5.0	pF
$C_{PD}$	Power Dissipation Capacitance	$V_{CCA} = V_{CCB} = 3.3V$ , $V_I = 0V$ or $V_{CC}$ , $F = 10MHz$	20.0	pF

## AC Loading and Waveforms

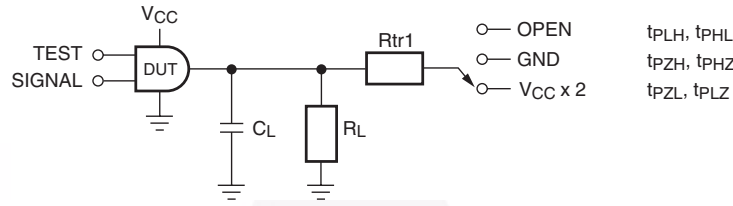

Test	Switch
$t_{PLH}, t_{PHL}$	OPEN
$t_{PLZ}, t_{PZL}$	$V_{CCO} \times 2$ at $V_{CCO} = 3.3 \pm 0.3V, 2.5V \pm 0.2V, 1.8V \pm 0.15V, 1.5V \pm 0.1V, 1.2V \pm 0.1V$
$t_{PHZ}, t_{PZH}$	GND

Figure 1. AC Test Circuit

### AC Load Table

$V_{CCO}$	$C_L$	$R_L$	$R_{tr1}$
$1.2V \pm 0.1V$	15pF	2k $\Omega$	2k $\Omega$
$1.5V \pm 0.1V$	15pF	2k $\Omega$	2k $\Omega$
$1.8V \pm 0.15V$	15pF	2k $\Omega$	2k $\Omega$
$2.5V \pm 0.2V$	15pF	2k $\Omega$	2k $\Omega$
$3.3V \pm 0.3V$	15pF	2k $\Omega$	2k $\Omega$

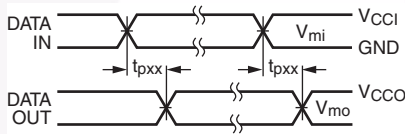

Input  $t_R = t_F = 2.0$  ns, 10% to 90%  
 Input  $t_R = t_F = 2.5$  ns, 10% to 90%, @  $V_I = 3.0V$  to  $3.6V$  only

Figure 2. Waveform for Inverting and Non-Inverting Functions

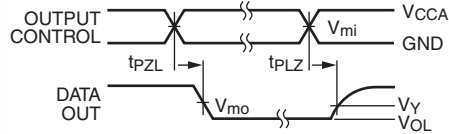

Input  $t_R = t_F = 2.0$  ns, 10% to 90%  
 Input  $t_R = t_F = 2.5$  ns, 10% to 90%, @  $V_I = 3.0V$  to  $3.6V$  only

Figure 3. 3-STATE Output Low Enable and Disable Times for Low Voltage Logic

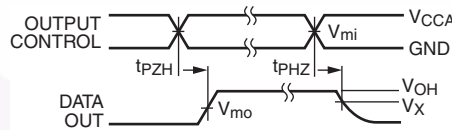

Input  $t_R = t_F = 2.0$  ns, 10% to 90%  
 Input  $t_R = t_F = 2.5$  ns, 10% to 90%, @  $V_I = 3.0V$  to  $3.6V$  only

Figure 4. 3-STATE Output High Enable and Disable Times for Low Voltage Logic

Symbol	$V_{CC}$				
	$3.3V \pm 0.3V$	$2.5V \pm 0.2V$	$1.8V \pm 0.15V$	$1.5V \pm 0.1V$	$1.2V \pm 0.1V$
$V_{mi}$	$V_{CCI}/2$	$V_{CCI}/2$	$V_{CCI}/2$	$V_{CCI}/2$	$V_{CCI}/2$
$V_{mo}$	$V_{CCO}/2$	$V_{CCO}/2$	$V_{CCO}/2$	$V_{CCO}/2$	$V_{CCO}/2$
$V_X$	$V_{OH} - 0.3V$	$V_{OH} - 0.15V$	$V_{OH} - 0.15V$	$V_{OH} - 0.1V$	$V_{OH} - 0.1V$
$V_Y$	$V_{OL} + 0.3V$	$V_{OL} + 0.15V$	$V_{OL} + 0.15V$	$V_{OL} + 0.1V$	$V_{OL} + 0.1V$

For  $V_{mi}$ :  $V_{CCI} = V_{CCA}$  for Control Pins  $T/\bar{R}$  and  $\bar{OE}$ , or  $V_{CCA}/2$

## Tape and Reel Specification

### Tape Format for DQFN 10

Package Designator	Tape Section	Number Cavities	Cavity Status	Cover Tape Status
BQX	Leader (Start End)	125 (typ)	Empty	Sealed
	Carrier	2500/3000	Filled	Sealed
	Trailer (Hub End)	75 (typ)	Empty	Sealed

### Tape Dimensions millimeters

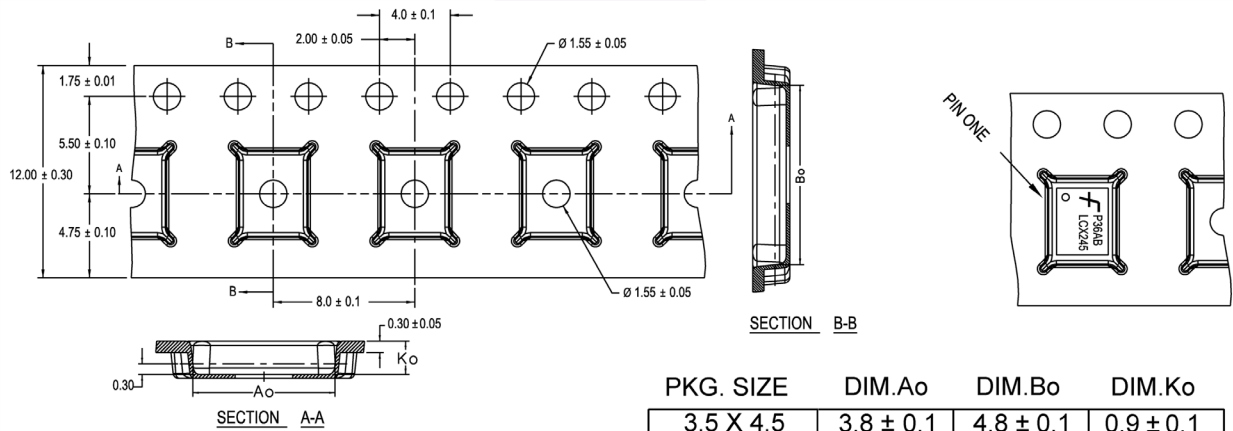

NOTES: unless otherwise specified

1. Cumulative pitch for feeding holes and cavities (chip pockets) not to exceed 0.008[0.20] over 10 pitch span.
2. Smallest allowable bending radius.
3. Thru hole inside cavity is centered within cavity.
4. Tolerance is ±0.002[0.05] for these dimensions on all 12mm tapes.
5. Ao and Bo measured on a plane 0.120[0.30] above the bottom of the pocket.
6. Ko measured from a plane on the inside bottom of the pocket to the top surface of the carrier.
7. Pocket position relative to sprocket hole measured as true position of pocket. Not pocket hole.
8. Controlling dimension is millimeter. Dimension in inches rounded.

**Reel Dimensions** inches (millimeters)

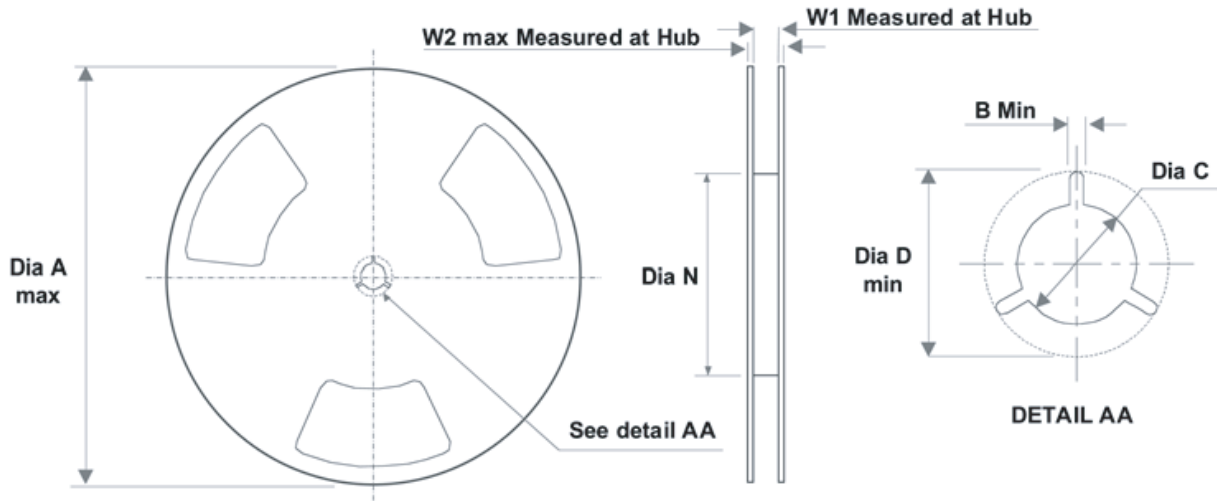

Tape Size	A	B	C	D	N	W1	W2
12 mm	13.0 (330)	0.059 (1.50)	0.512 (13.00)	0.795 (20.20)	7.008 (178)	0.488 (12.4)	0.724 (18.4)

## Physical Dimensions

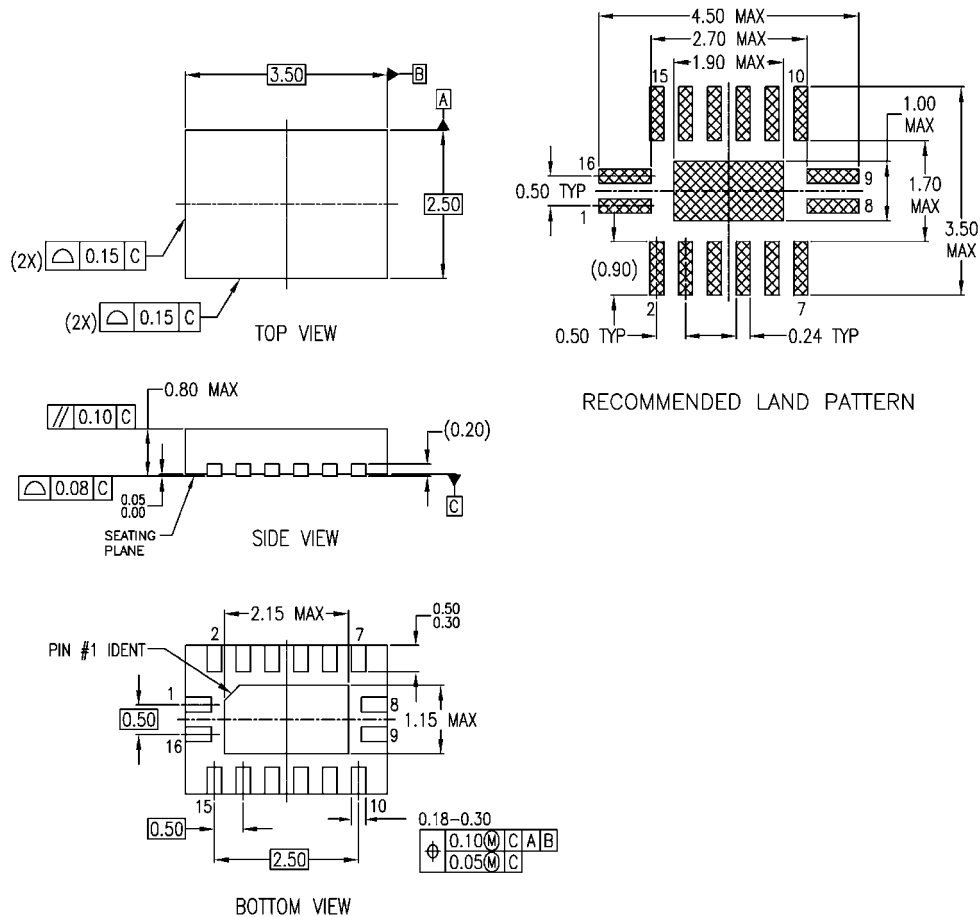

### NOTES:

- CONFORMS TO JEDEC REGISTRATION MO-241, VARIATION AB
- DIMENSIONS ARE IN MILLIMETERS.
- DIMENSIONS AND TOLERANCES PER ASME Y14.5M, 1994

MLP016ErevA

**Figure 5. 16-Terminal Depopulated Quad Very-Thin Flat Pack No Leads (DQFN), JEDEC MO-241 2.5 x 3.5mm**

Package drawings are provided as a service to customers considering Fairchild components. Drawings may change in any manner without notice. Please note the revision and/or date on the drawing and contact a Fairchild Semiconductor representative to verify or obtain the most recent revision. Package specifications do not expand the terms of Fairchild's worldwide terms and conditions, specifically the warranty therein, which covers Fairchild products.

Always visit Fairchild Semiconductor's online packaging area for the most recent package drawings:

<http://www.fairchildsemi.com/packaging/>

### Physical Dimensions

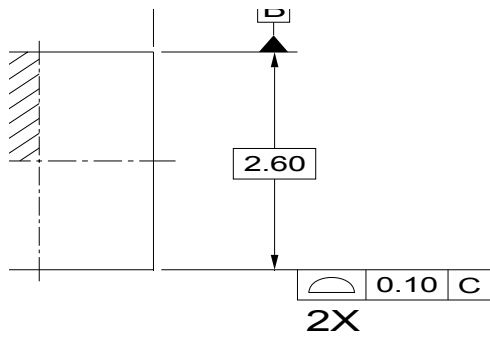

P VIEW

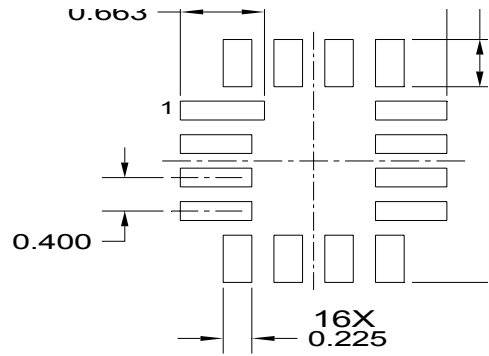

RECOMMENDED LAND I

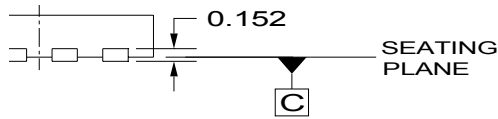

E VIEW

TERMINAL SHAPE V

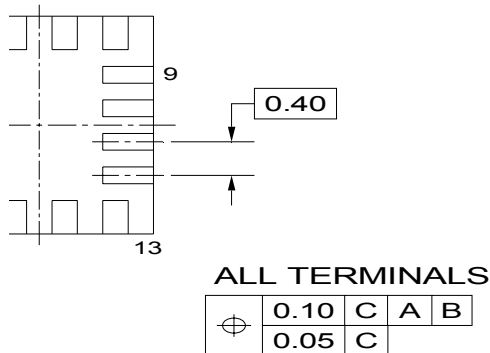

TOM VIEW

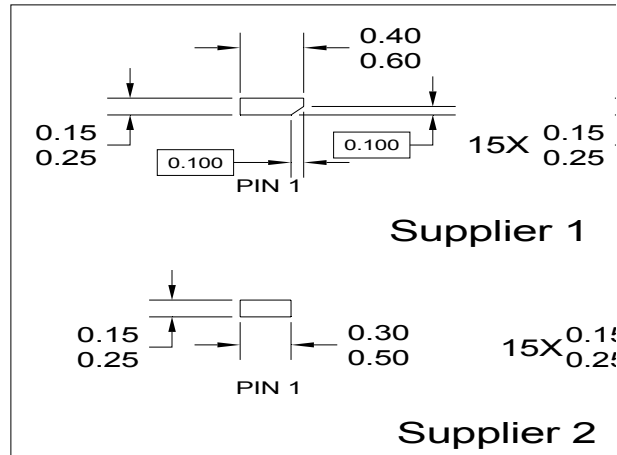

IS NOT CURRENTLY REGISTERED WITH THE IEC 60110-100 COMMITTEE





Figure 5. 16-Terminal Quad, Ultrathin, Molded Leadless Package (UMLP), 1.8mm x 2.6mm

Package drawings are provided as a service to customers considering Fairchild components. Drawings may change in any manner without notice. Please note the revision and/or date on the drawing and contact a Fairchild Semiconductor representative to verify or obtain the most recent revision. Package specifications do not expand the terms of Fairchild's worldwide terms and conditions, specifically the warranty therein, which covers Fairchild products.

Always visit Fairchild Semiconductor's online packaging area for the most recent package drawings:  
<http://www.fairchildsemi.com/packaging/>

**TRADEMARKS**

The following includes registered and unregistered trademarks and service marks, owned by Fairchild Semiconductor and/or its global subsidiaries, and is not intended to be an exhaustive list of all such trademarks.

Build it Now™	FRFET®	Programmable Active Droop™	
CorePLUS™	Global Power Resource™	QFET®	
CorePOWER™	Green FPST™	QST™	TinyBoost™
CROSSVOLT™	Green FPST™ e-Series™	Quiet Series™	TinyBuck™
CTL™	GTO™	RapidConfigure™	TinyLogic®
Current Transfer Logic™	IntelliMAX™		TINYOPTO™
EcoSPARK®	ISOPLANAR™		Saving our world, 1mW/W/kW at a time™
EfficientMax™	MegaBuck™	SmartMax™	TinyPWM™
EZSWITCH™	MICROCOUPLER™	SMART START™	TinyWire™
	MicroFET™	SPM®	TriFault Detect™
	MicroPak™	STEALTH™	TRUECURRENT™
	MillerDrive™	SuperFET™	μSerDes™
	MotionMax™	SuperSOT™.3	
Fairchild®	Motion-SPM™	SuperSOT™.8	
Fairchild Semiconductor®	OPTOLOGIC®	SupreMOS™	Ultra FRFET™
FACT Quiet Series™	OPTOPLANAR®	SyncFET™	UniFET™
FACT®		SYSTEM GENERAL	VCX™
FAST®		PDP SPM™	The Power Franchise®
FastvCore™	Power-SPM™		XST™
FlashWriter®	PowerTrench®		
FPST™	PowerXS™		
F-PFST™			

\* Trademarks of System General Corporation, used under license by Fairchild Semiconductor.

**DISCLAIMER**

FAIRCHILD SEMICONDUCTOR RESERVES THE RIGHT TO MAKE CHANGES WITHOUT FURTHER NOTICE TO ANY PRODUCTS HEREIN TO IMPROVE RELIABILITY, FUNCTION, OR DESIGN. FAIRCHILD DOES NOT ASSUME ANY LIABILITY ARISING OUT OF THE APPLICATION OR USE OF ANY PRODUCT OR CIRCUIT DESCRIBED HEREIN; NEITHER DOES IT CONVEY ANY LICENSE UNDER ITS PATENT RIGHTS, NOR THE RIGHTS OF OTHERS. THESE SPECIFICATIONS DO NOT EXPAND THE TERMS OF FAIRCHILD'S WORLDWIDE TERMS AND CONDITIONS, SPECIFICALLY THE WARRANTY THEREIN, WHICH COVERS THESE PRODUCTS.

**LIFE SUPPORT POLICY**

FAIRCHILD'S PRODUCTS ARE NOT AUTHORIZED FOR USE AS CRITICAL COMPONENTS IN LIFE SUPPORT DEVICES OR SYSTEMS WITHOUT THE EXPRESS WRITTEN APPROVAL OF FAIRCHILD SEMICONDUCTOR CORPORATION.

As used herein:

- Life support devices or systems are devices or systems which, (a) are intended for surgical implant into the body or (b) support or sustain life, and (c) whose failure to perform when properly used in accordance with instructions for use provided in the labeling, can be reasonably expected to result in a significant injury of the user.
- A critical component in any component of a life support, device, or system whose failure to perform can be reasonably expected to cause the failure of the life support device or system, or to affect its safety or effectiveness.

**ANTI-COUNTERFEITING POLICY**

Fairchild Semiconductor Corporation's Anti-Counterfeiting Policy. Fairchild's Anti-Counterfeiting Policy is also stated on our external website, [www.fairchildsemi.com](http://www.fairchildsemi.com), under Sales Support.

Counterfeiting of semiconductor parts is a growing problem in the industry. All manufacturers of semiconductor products are experiencing counterfeiting of their parts. Customers who inadvertently purchase counterfeit parts experience many problems such as loss of brand reputation, substandard performance, failed applications, and increased cost of production and manufacturing delays. Fairchild is taking strong measures to protect ourselves and our customers from the proliferation of counterfeit parts. Fairchild strongly encourages customers to purchase Fairchild parts either directly from Fairchild or from Authorized Fairchild Distributors who are listed by country on our web page cited above. Products customers buy either from Fairchild directly or from Authorized Fairchild Distributors are genuine parts, have full traceability, meet Fairchild's quality standards for handling and storage and provide access to Fairchild's full range of up-to-date technical and product information. Fairchild and our Authorized Distributors will stand behind all warranties and will appropriately address any warranty issues that may arise. Fairchild will not provide any warranty coverage or other assistance for parts bought from Unauthorized Sources. Fairchild is committed to combat this global problem and encourage our customers to do their part in stopping this practice by buying direct or from authorized distributors.

**PRODUCT STATUS DEFINITIONS**
**Definition of Terms**

Datasheet Identification	Product Status	Definition
Advance Information	Formative / In Design	Datasheet contains the design specifications for product development. Specifications may change in any manner without notice.
Preliminary	First Production	Datasheet contains preliminary data; supplementary data will be published at a later date. Fairchild Semiconductor reserves the right to make changes at any time without notice to improve design.
No Identification Needed	Full Production	Datasheet contains final specifications. Fairchild Semiconductor reserves the right to make changes at any time without notice to improve the design.
Obsolete	Not In Production	Datasheet contains specifications on a product that is discontinued by Fairchild Semiconductor. The datasheet is for reference information only.

Rev. I39