

E+PLC¹⁰⁰

User Guide

Compact Precision PLC

HA032001_2
April 2014

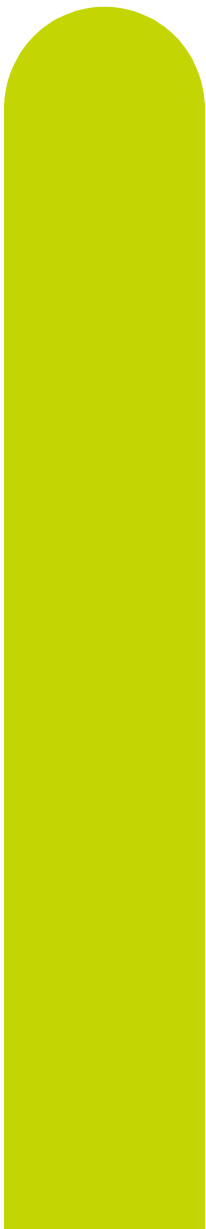

E+PLC100

User Guide

Contents List

Section

1 INTRODUCTION	4
1.1 UNPACKING THE INSTRUMENT	4
2 INSTALLATION	5
2.1 MECHANICAL INSTALLATION	5
2.1.1 Installation Procedure	5
2.1.2 Demounting	5
2.1.3 Removing the Instrument from its Sleeve	5
2.1.4 Dimensions and Panel Cut Out	6
2.2 ELECTRICAL INSTALLATION	6
2.2.1 Termination details	6
2.2.2 Low Voltage Option	8
3 OPERATION	9
3.1 INTRODUCTION TO THE DEFAULT APPLICATION	9
3.2 Navigation Diagram	10
3.3 demo	11
3.3.1 Features	11
3.4 Configure	12
3.4.1 Setting the IP address	12
3.4.2 Setting the time and date	12
3.5 Help Pages	13
3.6 Status Page	14
4 TO CONFIGURE E+PLC100 INPUT/OUTPUT	15
4.1 Open the CODESYS software	15
4.2 New Project	16
4.2.1 Select E+PLC100 project	16
To Select Analogue Input Type	17
To Select Option I/O Type	18
Module Configuration Tab	19
Module I/O Mapping Tab	19
4.2.2 Introduction to Producing a Strategy	21
4.2.3 Wiring	22
4.2.4 To Add a PID Control Block	22
Example 1: To wire Input1 to the PID loop	23
4.2.5 Example 2: Touch Screen Lock	24
5 LOADING A NEW APPLICATION	25
6 Accessing the CODESYS Online Help	26
6.1 CODESYS Library Documentation	27
6.2 Online tutorials and 'How to' videos	28
A Appendix A: TECHNICAL SPECIFICATION	29
A.1 INSTALLATION CATEGORY AND POLLUTION DEGREE	29
A.2 SPECIFICATION	30
A.2	34
B Appendix B: DISPLAY AND ACTIVE TOUCH SCREEN DIMENSIONS	35

C	Appendix C: HINTS AND TIPS	37
C.1	Recovery from excessive CPU loading	37
C.2	Recovery from invalid/forgotten network settings	37
C.3	Recovery in the event of a fully built up firewall	37
C.4	Line Voltage Measurement for Power Feed Forward Control	38
C.5	Watchdog functionality	38
C.6	Ensure all images are downloaded	38

SAFETY NOTES

WARNINGS

1. Any interruption of the protective conductor inside or outside the apparatus, or disconnection of the protective earth terminal is likely to make the apparatus dangerous under some fault conditions. Intentional interruption is prohibited.
 2. Live sensors: The unit is designed to operate if the temperature sensor is connected directly to an electrical heating element. It must be ensured that service personnel do not touch connections to such inputs whilst the inputs are live. With live sensors, all cables, connections and switches for connecting the sensor must be mains rated for use in 240V Cat II.
 3. Grounding the temperature sensor shield: Where it is common practice to replace the temperature sensor whilst the instrument is live, it is recommended that the shield of the temperature sensor be grounded to safety earth, as an additional protection against electric shock.
 4. The instrument must not be wired to a three-phase supply with an unearthed star connection, because, under fault conditions, such a supply could rise above 240V RMS with respect to ground, thus rendering the instrument unsafe.
-

BACK UP BATTERY

1. This instrument is fitted with a battery designed to retain configuration and other data in the event of failure of the power supply to the instrument.
 2. The battery has an expected life of >1 year unpowered at nominal operating temperature of 25°C, but this may be reduced if the instrument is operated at elevated temperatures. Low battery indication must be programmed into the application by the designer.
 3. The battery is not user serviceable.
-

Notes:

1. Safety requirements for permanently connected equipment state:
 - a. A switch or circuit breaker shall be included in the building installation.
 - b. It shall be in close proximity to the equipment and within easy reach of the operator.
 - c. It shall be marked as the disconnecting device for the equipment.
 2. Recommended external fuse ratings are: 2A Type T 250V.
-

1. This instrument is intended for industrial control applications within the requirements of the European directives on safety and EMC.
2. Installation may be carried out only by qualified personnel.
3. To prevent hands or metal tools coming into contact with parts that are electrically live the instrument must be installed in an enclosure.
4. Where conductive pollution (e.g. condensation, carbon dust) is likely, adequate air conditioning/filtering/sealing etc. must be installed in the enclosure.
5. The instrument is fitted with an over current protection device which is not user serviceable. If it is suspected that this has failed, the manufacturer's local service centre should be contacted for advice.
6. Whenever it is likely that protection has been impaired, the unit shall be made inoperative, and secured against accidental operation. The manufacturer's nearest service centre should be contacted for advice.
7. If the equipment is used in a manner not specified by the manufacturer, the protection provided by the equipment might be impaired.
8. The unit must be wired according to the instructions in this manual.
9. Before any other connection is made, the protective earth terminal shall be connected to a protective conductor. The mains (supply voltage) wiring must be terminated in such a way that, should it slip, the Earth wire would be the last wire to become disconnected. The protective earth terminal must remain connected (even if the equipment is isolated from the mains supply), if any of the I/O circuits are con-

nected to hazardous voltages (A full definition of 'Hazardous' voltages appears under 'Hazardous live' in BS EN61010. Briefly, under normal operating conditions, hazardous voltages are defined as being > 30V RMS (42.2V peak) or > 60V dc.)

The protective earth connection must always be the first to be connected and the last to be disconnected.

Wiring must comply with all local wiring regulations, e.g. in the UK, the latest IEEE wiring regulations (BS7671) and in the USA, NEC class 1 wiring methods.

10. Signal and supply voltage wiring should be kept separate from one another. Where this is impractical, shielded cables should be used for the signal wiring.
11. The maximum continuous voltage applied between any of the following terminals must not exceed 240Vac.
 1. Relay output to logic, dc or sensor input connections
 2. Any connection to ground.

The ac supply must not be connected to sensor input or low-level inputs or outputs.









12. Over temperature protection: A separate over-temperature protection unit (with an independent temperature sensor) should be fitted to isolate any process heating circuit should a fault condition arise. Alarm relays within the instrument do not give protection under all fault conditions.
13. In order to allow the power supply capacitors to discharge to a safe voltage, the supply must be disconnected at least two minutes before the instrument is removed from its sleeve. Touching exposed electronics in an instrument which has been removed from its sleeve should be avoided.
14. Instrument labels may be cleaned using iso-propyl alcohol, or water or water-based products. A mild soap solution may be used to clean other exterior surfaces.

USB DEVICE PRECAUTIONS

Note: the use of U3 USB Flash drives is not recommended.

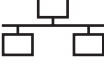
1. Precautions against electrostatic discharge should be taken when the instrument terminals are being accessed. The USB and Ethernet connections are particularly vulnerable.
2. Ideally, the USB device should be plugged directly into the instrument, as the use of extension leads may compromise the instrument's ESD compliance. Where the instrument is being used in an electrically 'noisy' environment, however, it is recommended that the user brings the USB socket to the front of the panel using a short extension lead. This is because the USB may 'lock up' or reset in noisy environments and the only means of recovery is to remove the device, then re-insert it. For memory sticks, EMC-related failure during a write operation might cause corruption of the data held on the stick. For this reason, the data on the memory stick should be backed up before insertion and checked after removal.
3. When using a USB extension cable, a high quality screened cable must be used. The total length of USB cable between the device and the USB port must not exceed 3 metres (10 ft.) .

SYMBOLS USED ON THE INSTRUMENT LABELLING

	Refer to manual for instructions		Risk of electric shock
	This unit is CE approved		Precautions against static electrical discharge must be taken when handling this unit
	C-Tick mark for Australia (ACA) and New Zealand (RSM)		Ethernet connector
	Underwriters laboratories listed mark for Canada and the U.S.A.		USB connector
	For environmental reasons, this unit must be recycled before its age exceeds the number of years shown in the circle.		Protective conductive terminal (Safety Earth)

One or more of the symbols above may appear as a part of the recorder labelling.

1 INTRODUCTION

This document describes the installation of the E+PLC100 hardware, an explanation of the default application and an introduction to CODESYS software. The instrument comes with four input channels as standard. It is equipped for secure archiving via FTP transfer and/or to USB memory stick.

1.1 UNPACKING THE INSTRUMENT

The instrument is despatched in a special pack, designed to give adequate protection during transit. Should the outer box show signs of damage, it should be opened immediately, and the contents examined. If there is evidence of damage, the instrument should not be operated and the local representative contacted for instructions. After the instrument has been removed from its packing, the packing should be examined to ensure that all accessories and documentation have been removed. The packing should then be stored against future transport requirements.

2 INSTALLATION

CAUTION

Before installation, ensure that the specified instrument supply voltage matches the facility supply.

2.1 MECHANICAL INSTALLATION

Figure 2.1.1 gives installation details.

2.1.1 Installation Procedure

1. If it is not already in place, fit the sealing gasket behind the front bezel of the instrument.
2. Insert the instrument through the panel cutout, from the front of the panel.
3. Spring the retaining clips into place, and secure the instrument by holding it firmly in place whilst pushing both clips towards the rear face of the panel.
4. The protective membrane can now be removed from the display.

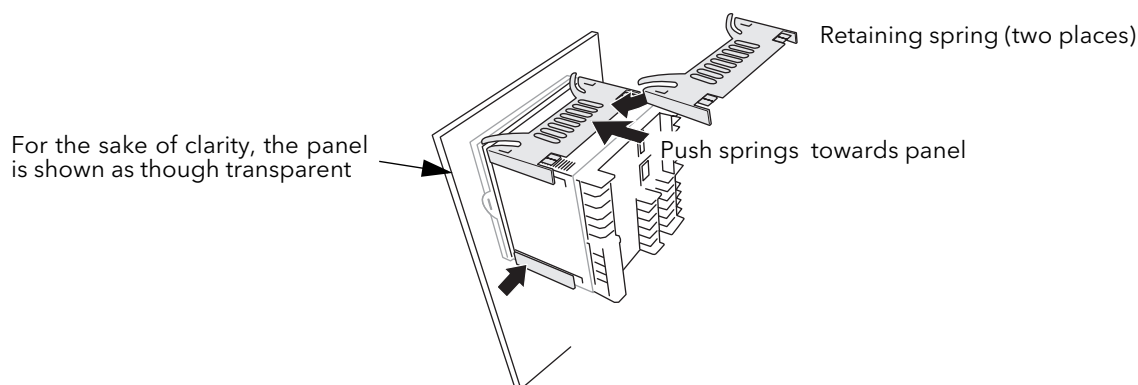

Figure 2.1.1 Securing the Instrument

2.1.2 Demounting

This section describes un-installation of the complete instrument including the sleeve.

WARNING

Before removing the supply voltage wiring, isolate the supply voltage and secure it against unintended operation.

1. Isolate the mains supply and secure it against accidental operation. Remove all wiring and the USB device and Ethernet cable (if any).
2. Remove the retaining springs by unhooking them from the sides using a small flat-blade screwdriver.
3. Pull the instrument forwards out of the panel.

2.1.3 Removing the Instrument from its Sleeve

The instrument is designed to be removed from its sleeve from the front panel. However, if a USB memory stick or the Ethernet cable is fitted then this must be removed first.

When the instrument is shipped from the factory it is fitted with two small red clips, one in the top side of the sleeve and the other below. These are intended as a safeguard against removal of the instrument from its sleeve when an Ethernet cable is fitted. These clips must also be removed, using a small screwdriver, before the instrument can be taken out of its sleeve.

Ease the latching ears (Figure 2.1) outwards and pull the controller forward.

When plugging back in ensure that the latching ears click into place to maintain the panel sealing.

2.1.4 Dimensions and Panel Cut Out

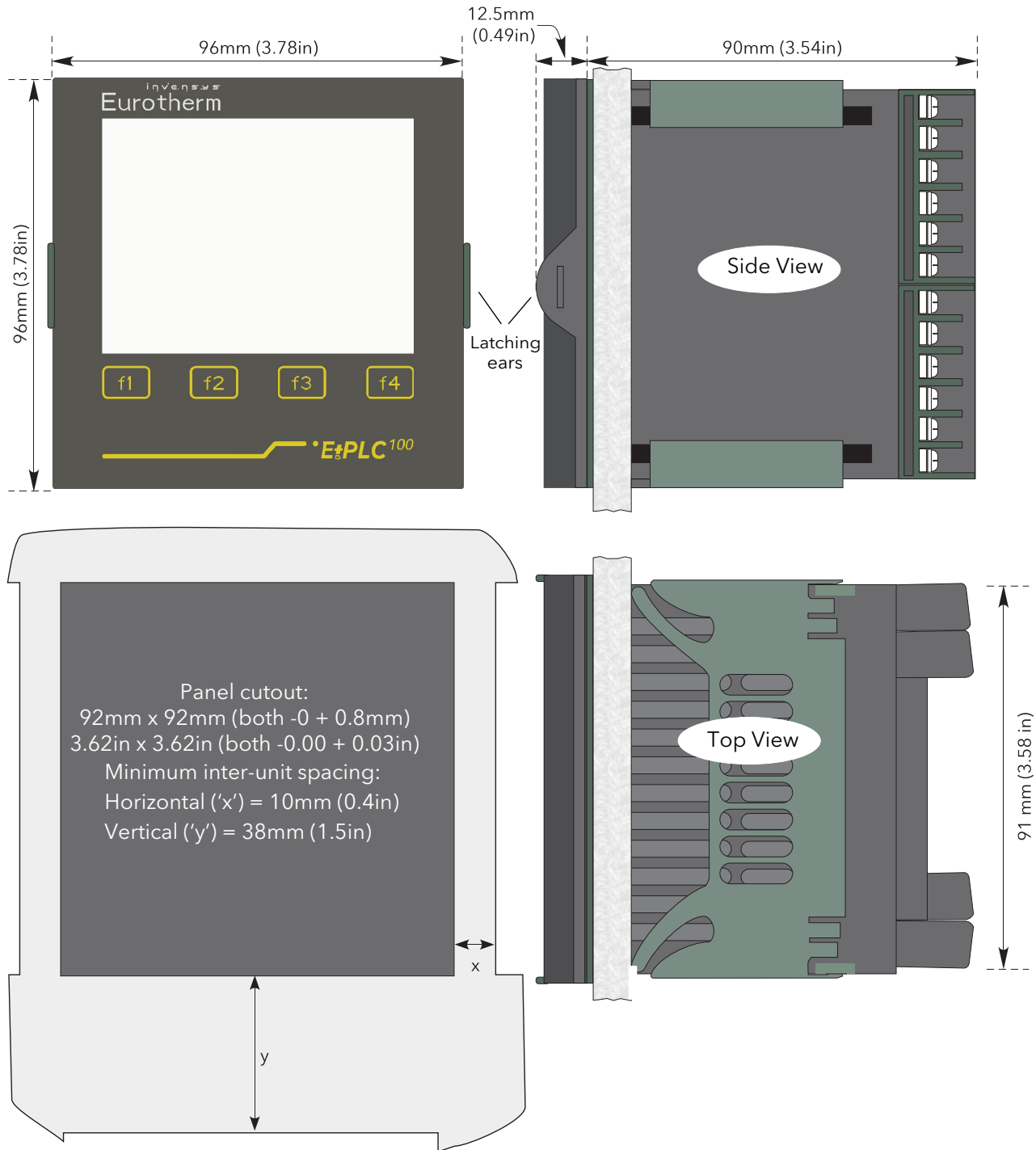

Figure 2.1 Mechanical installation details

2.2 ELECTRICAL INSTALLATION

Figure 2.2 shows the locations of the various user terminations along with signal and supply wiring pin-outs.

2.2.1 Termination details

The screw terminals accept single wires in the range 0.21 to 2.08 mm² (24 to 14 AWG) inclusive, or two wires each in the range 0.21 to 1.31 mm² (24 to 16 AWG) inclusive.

Screw terminals should be tightened to a torque not exceeding 0.4Nm (3.54 lb in)

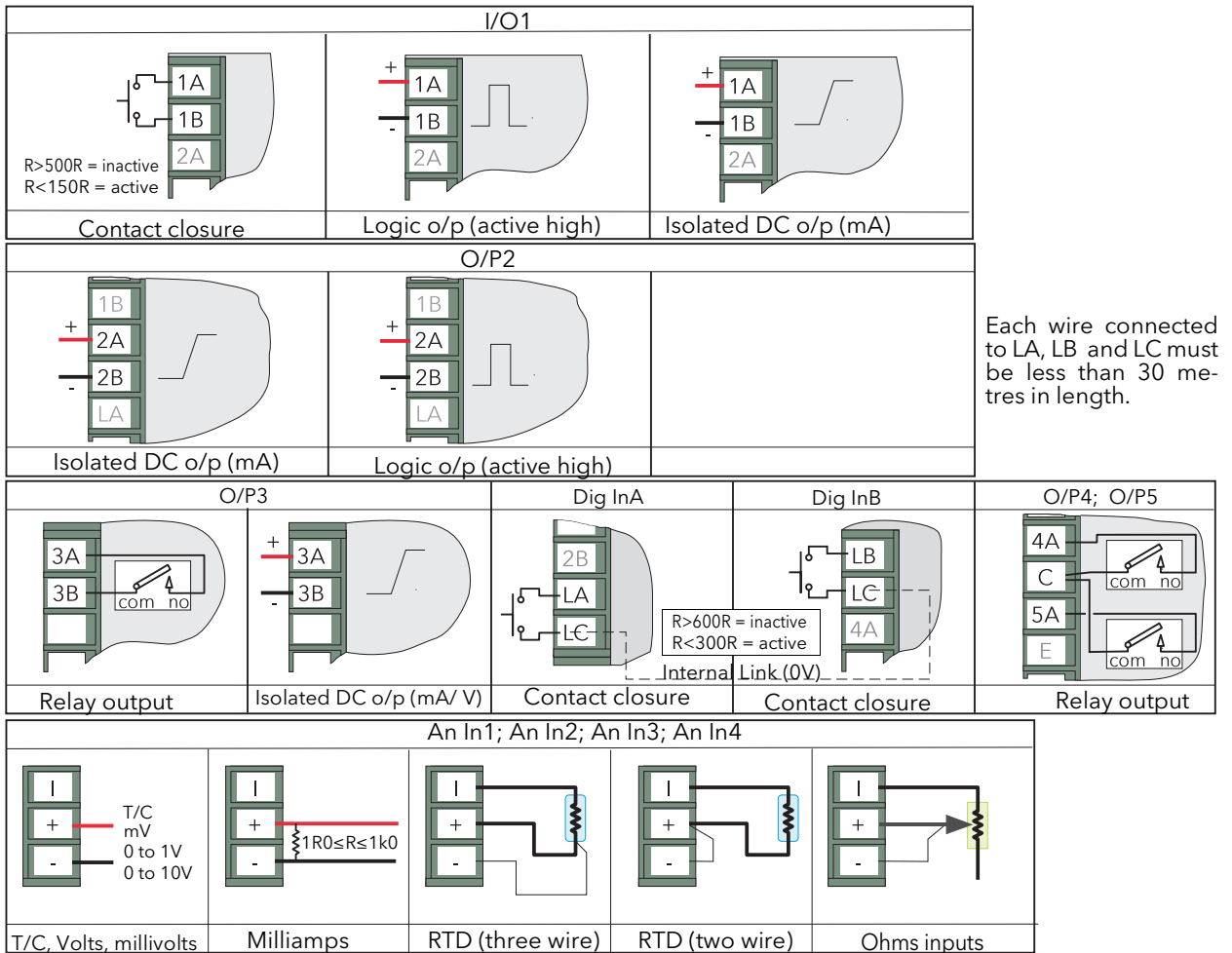
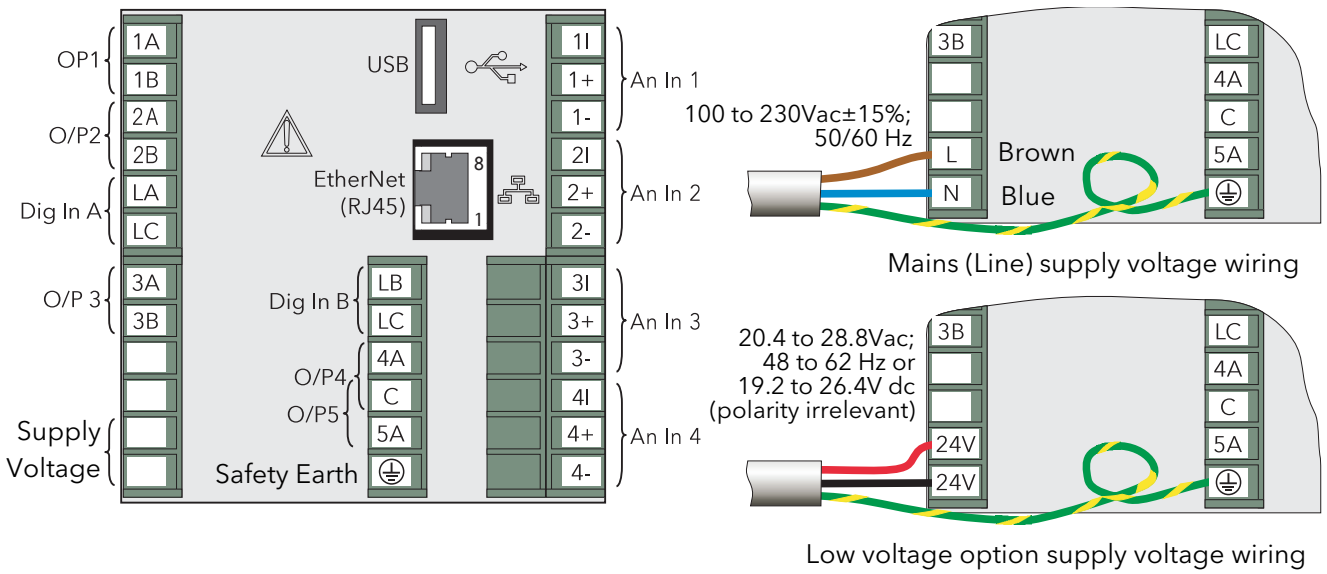

For thermocouples use the correct type of compensating cable and maintain polarity throughout.
 For milliamp input, this must be configured as a voltage input with an ohms law calculation in the strategy to convert to current.
 For other connections use conductors only.
 The power supply input is not fuse protected. This should be provided externally

Figure 2.2 Connector locations and pin-outs (rear panel)

2.2.2 Low Voltage Option

This option allows the use of a low voltage ac or dc 24 V supply. The specification in Appendix A gives full details. The polarity of the dc supply connection is not important - it may be connected either way round.

3 OPERATION

When the instrument is initialising a splash screen is displayed.

This is followed by a white screen for up to 10 seconds, followed by the visualisation that forms part of the CODESYS application.

New instruments are pre-loaded with a default application which may be used to provide an introduction to the instrument features and a method of setting the network configuration and time/date.

Note: A typical start up time for the instrument is about 90 seconds. Large applications may take longer to load but the majority (90-95%) of the typical start up time is for instrument initialisation.



Warning

The default application must be removed when the user application is installed. Removing an application does NOT default the network settings, nor the time/date. Therefore, if users do not require these to be changed again, then the user application does not have to include mechanisms to change them. If, however, network settings, and time/date may need to be changed in the future, the user application must include a method of setting them.

When removing an application please refer to section 4 for instructions.

3.1 INTRODUCTION TO THE DEFAULT APPLICATION

The default application opens a 'home' screen which provides navigation to four page headers via the f1 to f4 touch sensitive buttons. The default application is available from the E+PLC installed location, typically:

C:\Program Files(x86)\Eurotherm\E+PLC\E+PLC100|DefaultApplication.

f1 = **demo**. This allows access to a simple demonstration application.

f2 = **configure**. This allows IP addresses and time and date settings to be configured.

f3 = **help**. This selects a help page.

f4 = **status**. This shows the state of analogue and digital I/O.

Note:

f1 to f4 have different functions when other pages have been selected - generally as follows:

f1 Return to home page

f2 Continuous scroll around the four header pages.

f3 'back' function

f4 'forward' function

Please refer to the navigation diagram section 3.2.

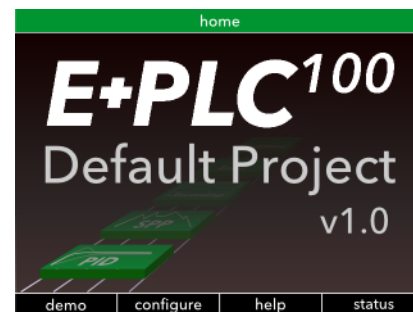

3.3 demo

This page shows a mimic of a hypothetical vacuum furnace which performs a simple ramp/dwell temperature sequence.

The two temperature zones follow a ramp up, dwell and ramp down sequence with events occurring at specific times. These events are displayed in the message boxes as the sequence progresses.

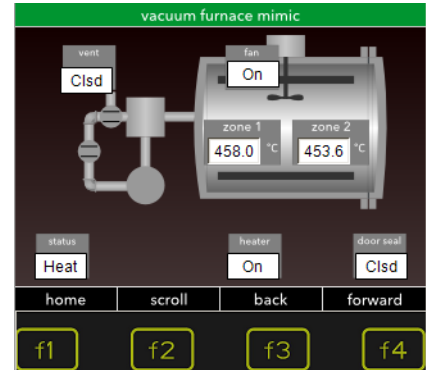
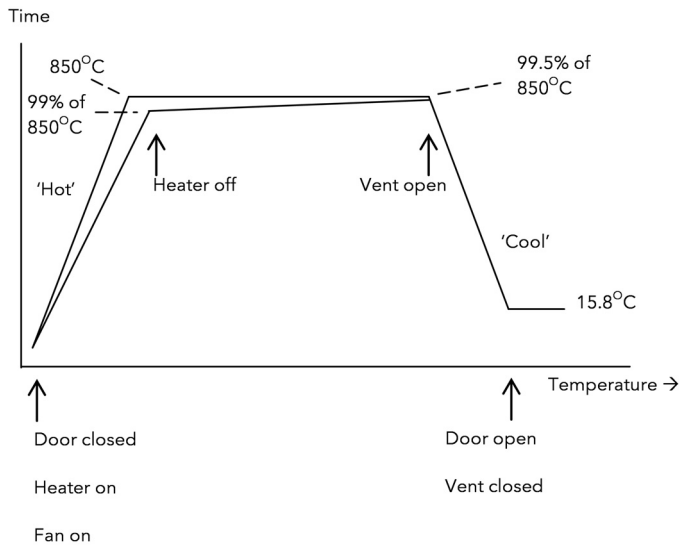

3.3.1 Features

Press f4 'forward' to display a list of features followed by those in current development.

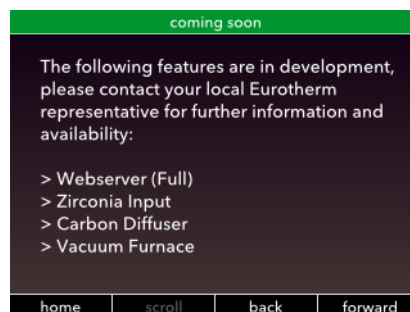
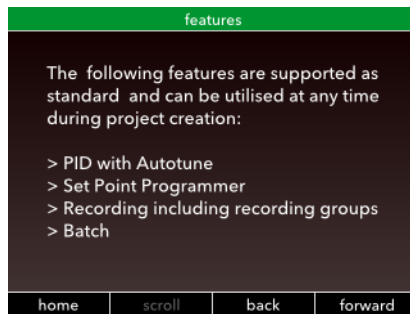

3.4 Configure

Configuration pages allow the network settings and time/date to be set up.

3.4.1 Setting the IP address

Click into the IP address to set. The 'number' pad appears. Enter the required address and 'accept'. 'escape' closes the number pad and 'clear' returns to the previously entered address

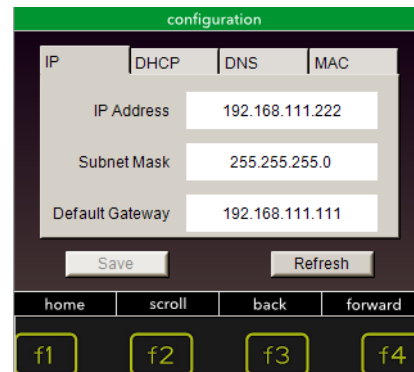
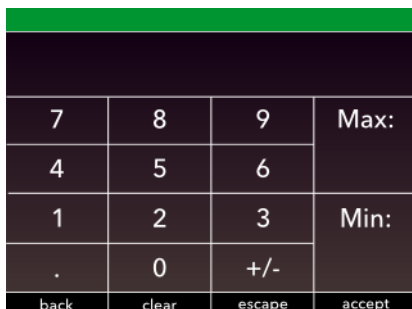

The same procedure is followed for the Subnet Mask and Default Gateway.

Note: the addresses cannot be changed if a contact is made between terminals LA and LC (Dig In 1). This is to protect against unauthorised changes.

Please refer to the Warning note in section 4 if the demonstration is removed and replaced by the user program.

Also from this page access to further methods of setting the address is possible:-

DHCP

DNS

MAC address. This is read only

3.4.2 Setting the time and date

From the configuration page, press f4 (forward)

Click into the setting to access the number pad and enter the correct time followed by date.



3.5 Help Pages

The 'help' page provides access to a number of screens as shown below:

HOME PAGE

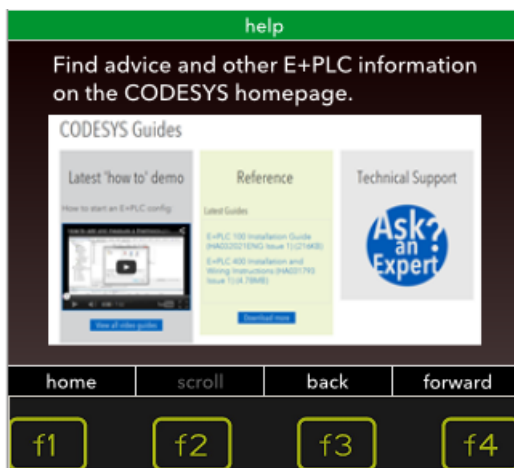

MAIN PAGE

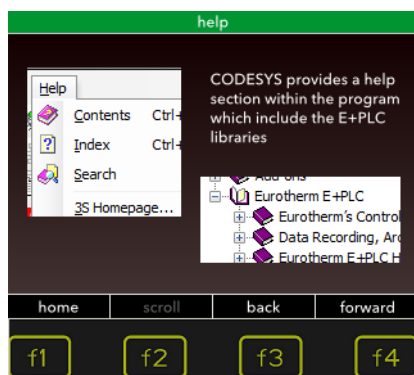

STARTING CODESYS

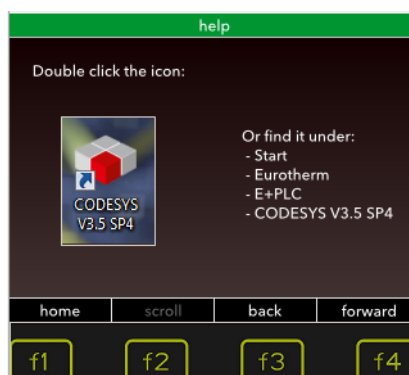

PROJECT PAGE

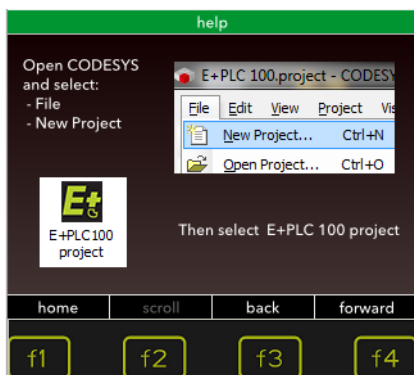

RESET PAGE

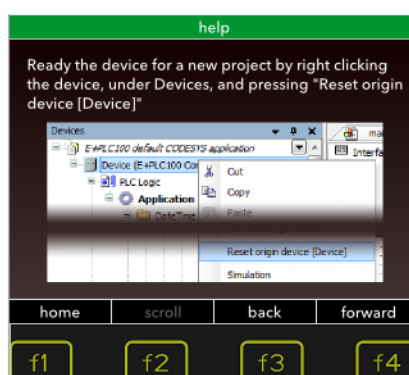

3.6 Status Page

This page shows the status of the I/O. The first page shows the status of the analogue and digital inputs.

The Digital Input 1 indicator can be turned on by closing the contact on terminals LA and LC (Dig In A).

The Digital Input 2 indicator can be turned on by closing the contact on terminals LB and LC (Dig In B).

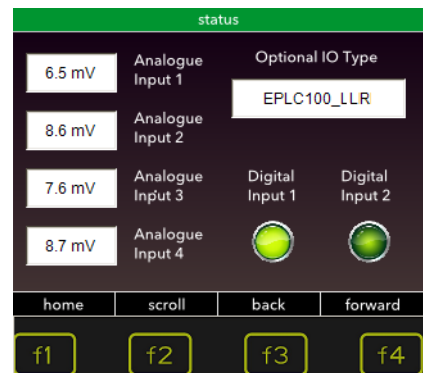

Press 'forward' to show the status of the relay outputs. To change the state of the relays touch the relevant button on the screen.



4 TO CONFIGURE E+PLC100 INPUT/OUTPUT

The E+PLC100 is configured and monitored using the E+PLC software which includes the CODESYS IDE, running on a PC {Windows version 7}.

Connect the E+PLC100 to a pc running the CODESYS software using the Ethernet connection.

Please also refer to the 'How to' videos. These can be accessed through the web portal on the Start page displayed when CODESYS is first launched.

4.1 Open the CODESYS software

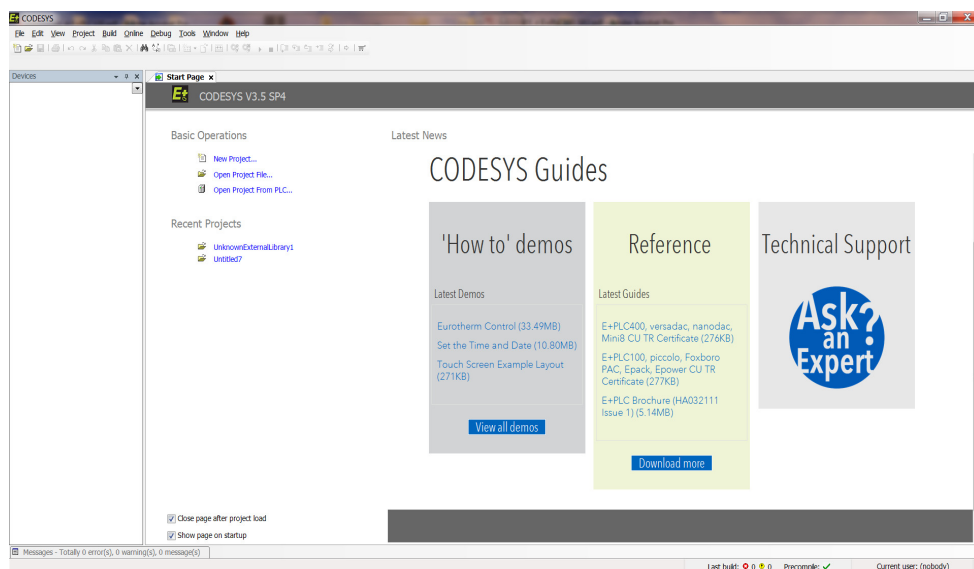

If the 'CODESYS Guides' section is not shown when first opened, select 'View' and 'Start Page'. In the section 'Latest News' a list of sample applications may be found.

4.2 New Project

Select New Project and give it a name, e.g. Application1.

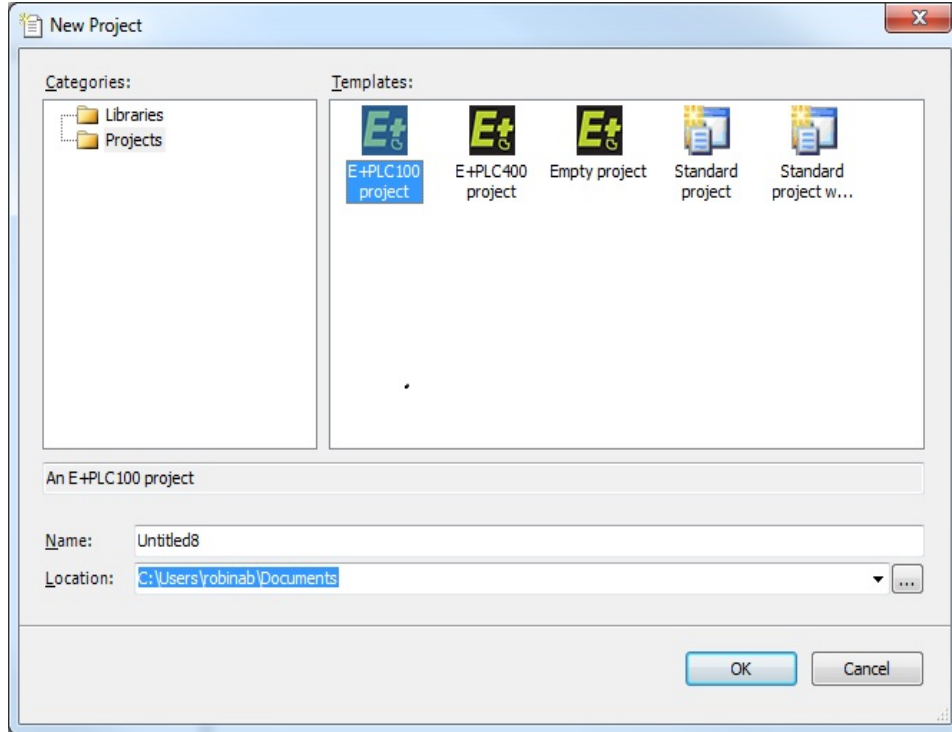

4.2.1 Select E+PLC100 project

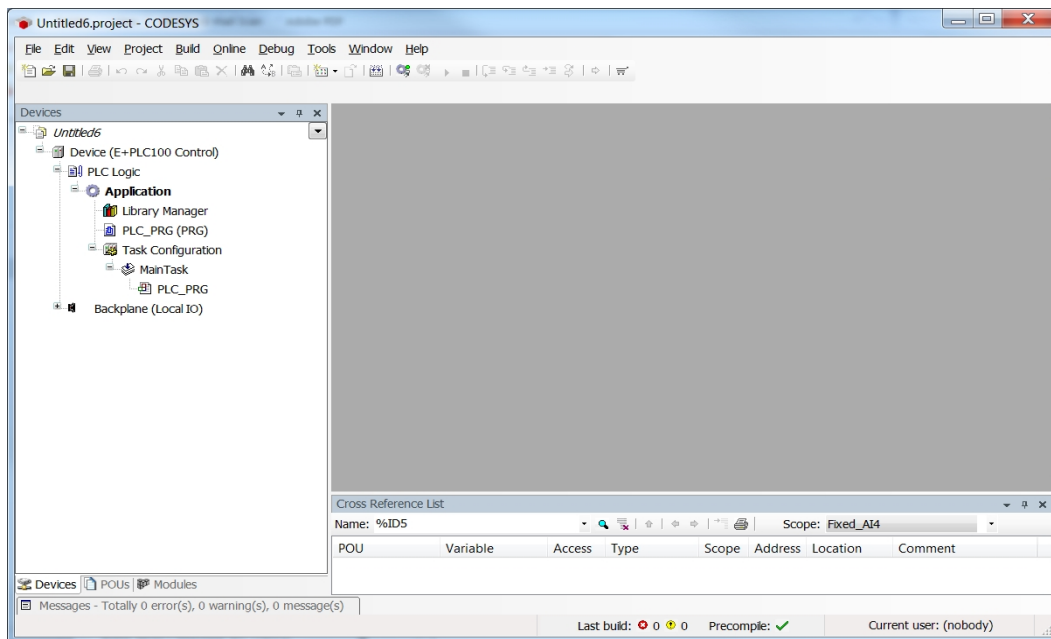

There is more than one way to define the I/O, but the most convenient may be to show it graphically using a view of the rear terminals.

Double click 'Backplane (Local IO)'

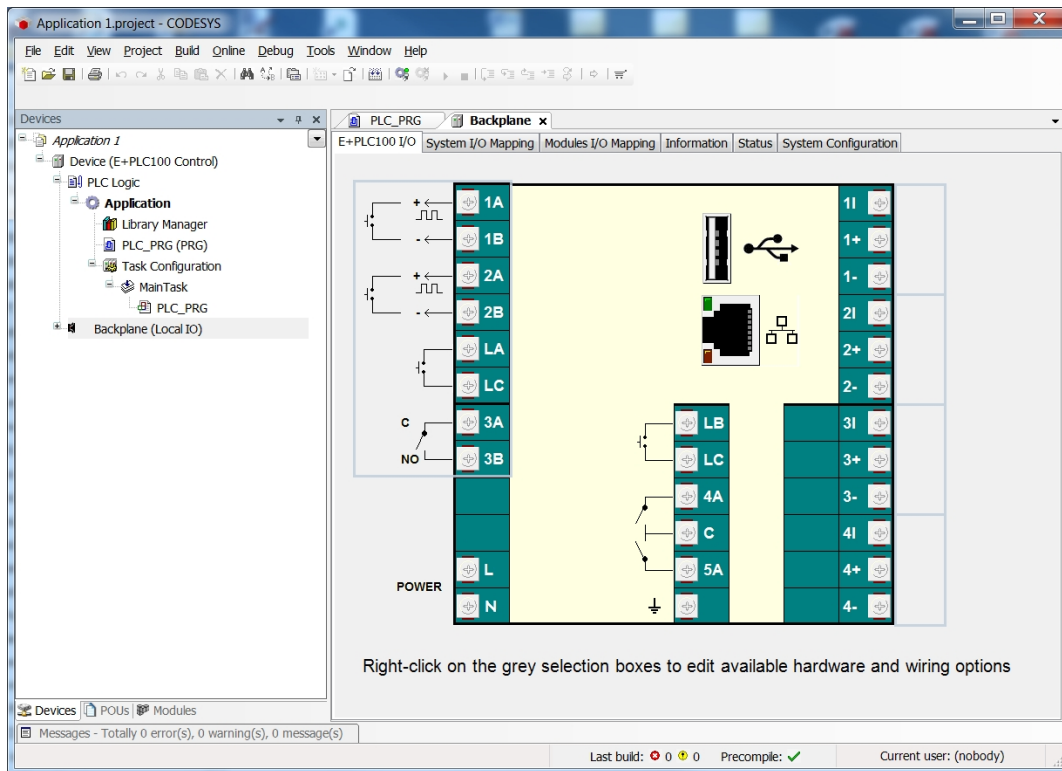

A view of the terminal block is shown. Click in any of the grey selection boxes to show a list of available input or output types. The list of available I/O is opened under the 'Backplane' folder.

4.2.1.1 To Select Analogue Input Type

Right click into the grey selection box next to the input to be configured, for example, 1I, 1+, 1- terminals (Input 1). Select the input type from:

- Off
- -40mV to +40mV
- -80mV to +80mV
- -3V to +10V
- -2V to +2V
- 3-Wire, 0 to 400 Ω (Platinum resistance thermometer)
- Thermocouple -40mV to +40mV
- Thermocouple -80mV to +80mV

Repeat for all four inputs.

A diagrammatic representation of the I/O type is shown connected to the relevant terminal. In the example shown:

Input 1 is a thermocouple

Input 2 is mV or V

Input 3 is configured as a 3 wire RTD. The physical input can be a 2-wire RTD by wiring it between 3I and 3+ with a link placed between 3+ and 3-.

Input 4 is a 3 wire PRT

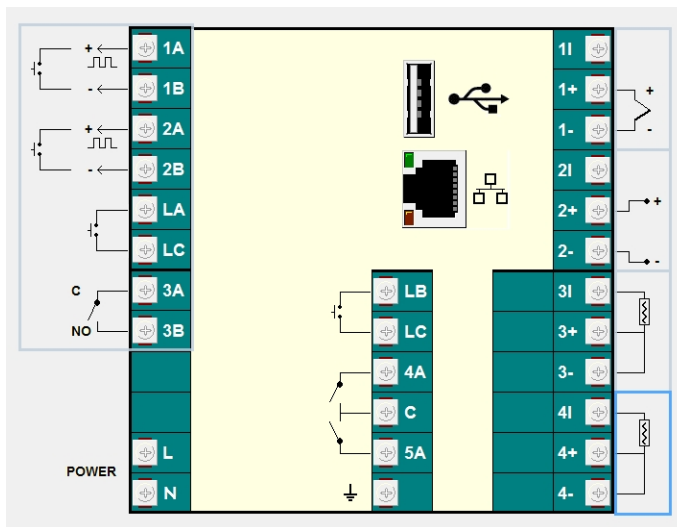

4.2.1.2 To Select Option I/O Type

Click in the grey selection box next to the option I/O terminals. The choices are:

OptionIO (DDD) Choose this option if the hardware of your device contains:
Isolated DC O/P on OP1, OP2 and OP3

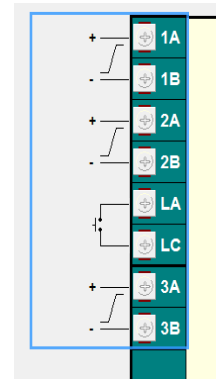

OptionIO (LLR) Choose this option if the hardware of your device contains:
OP1 = Logic input or output; OP2 = Logic input only; OP3 = normally open relay

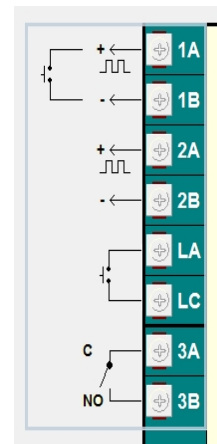

Plug Device This option in E+PLC100 is included for future development. In this release the above options are duplicated.

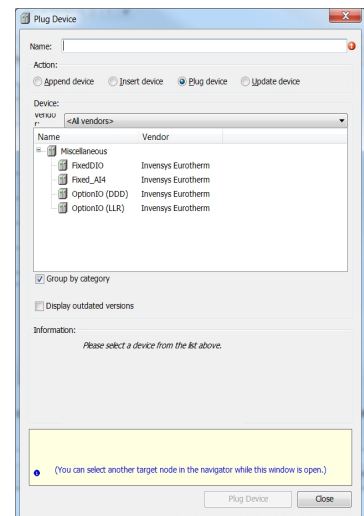

FixedDIO Not applicable to the current release

Fixed_AI4 Not applicable to the current release

4.2.1.3 Module Configuration Tab

Double click the path 'Fixed_AI4'. In the tab 'Module Configuration' a list of the analogue I/O is given.

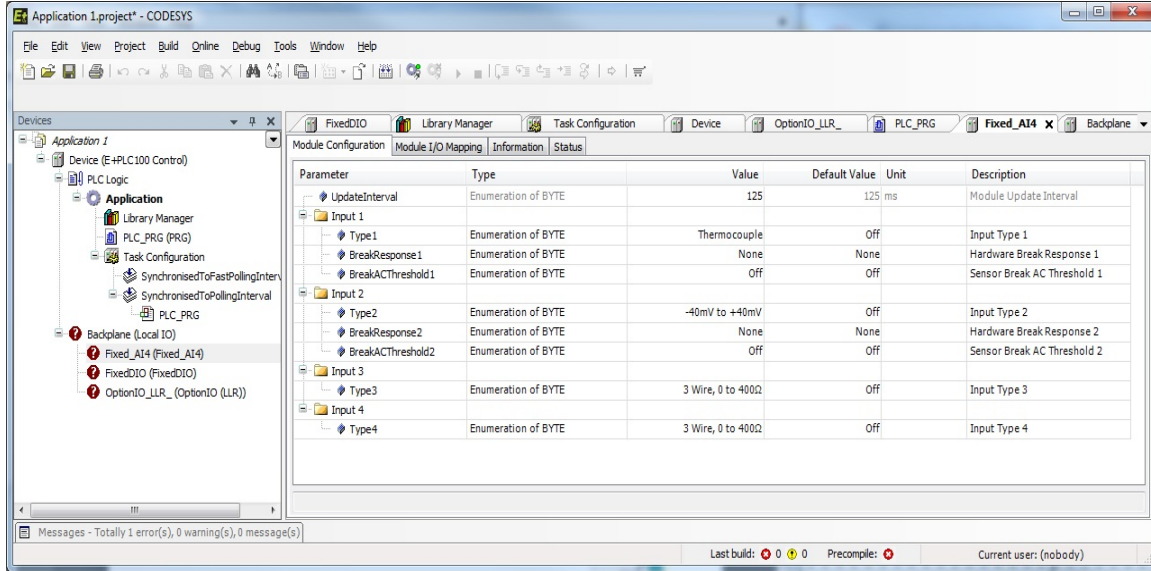

The I/O can also be configured from this menu as an alternative to the backplane view

4.2.1.4 Module I/O Mapping Tab

The tab 'Module I/O Mapping' shows the parameters associated with the I/O type. It also allows the source of the parameter to be defined. For example, to wire the container to physical input, double click in the 'Variable' column of the MV1 line. Provided that an application has been created (i.e. an input or output container has been defined as explained in section 5.2.3.) then, using the ellipsis, find the variable 'Input1' and double click. The name of the POU e.g. 'Application.PLC.PRG.Input1' will be displayed as shown below.

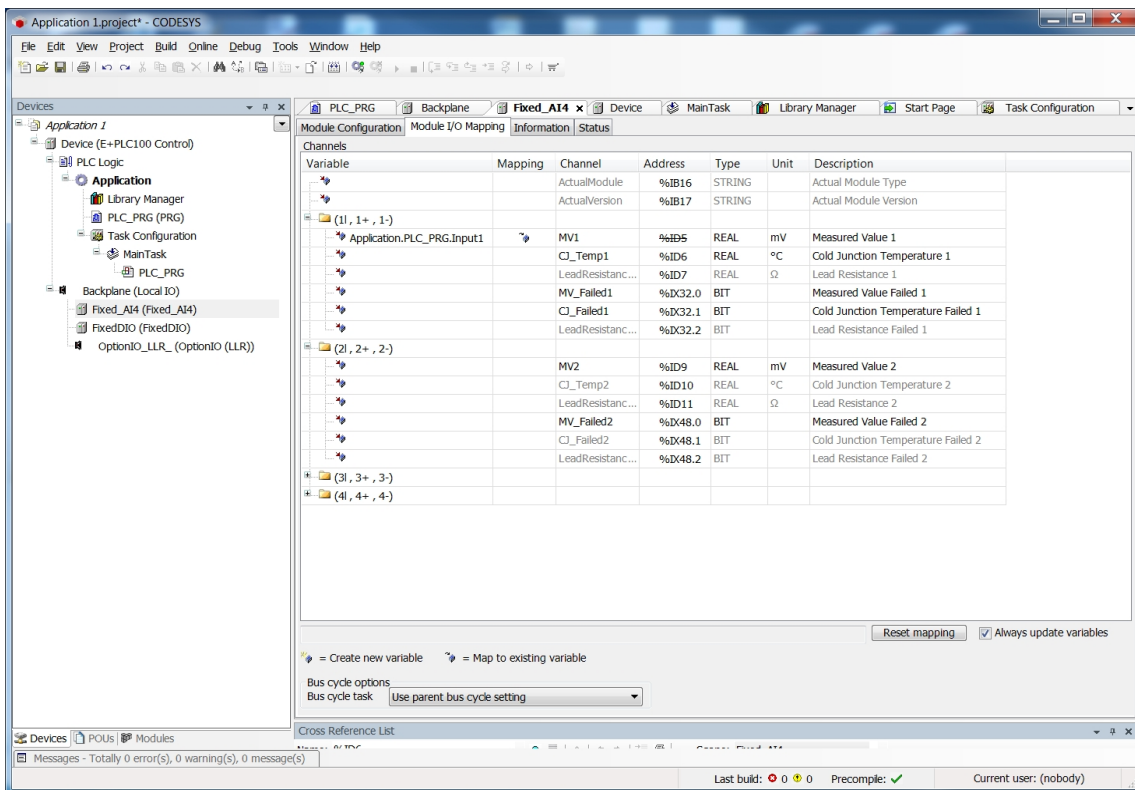

Similarly, double click the path 'FixedDIO' to show the Module Configuration of the Fixed IO.

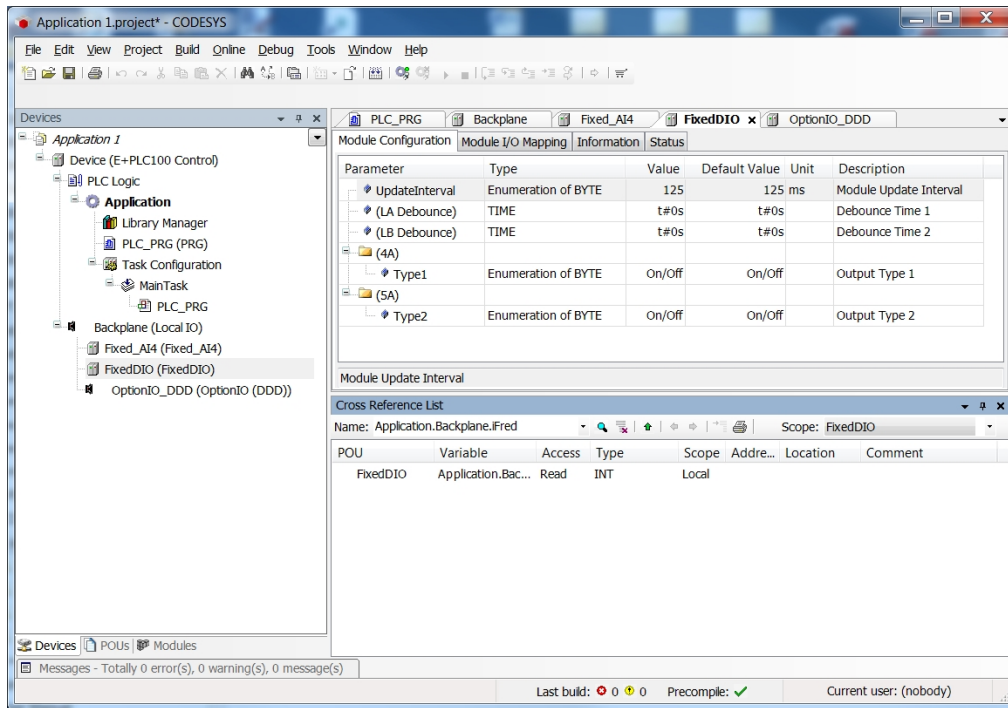

Or 'OptionIO' to show the Module Configuration of the variable IO

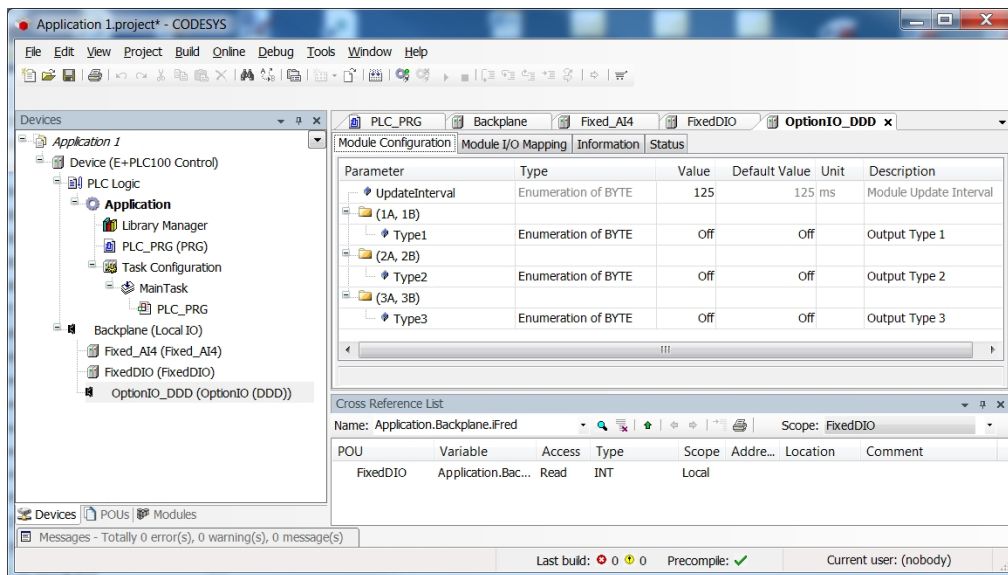

4.2.2 Introduction to Producing a Strategy

This section is intended as a very basic introduction to produce a real application. Double click the tab 'PLC_PRG'.

Example: To produce a 'container' for analogue input 1.

Drag an 'Input' from the ToolBox on the right hand side. This box is a container for a variable.

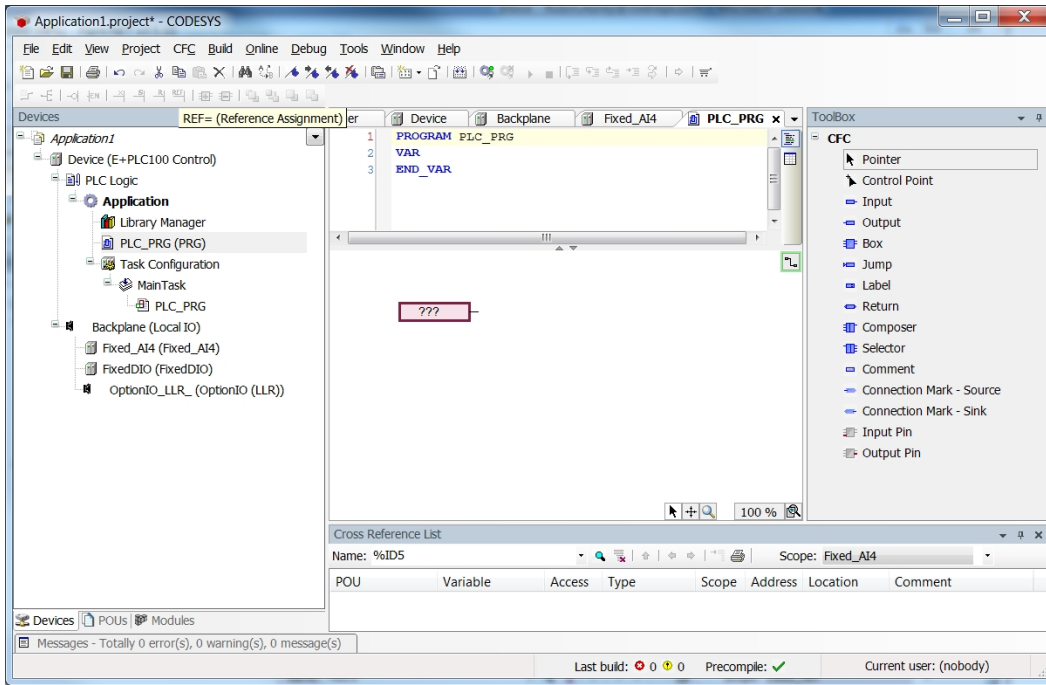

Type in a name e.g. **Input1**.

When enter is pressed the Auto Declare pop up is displayed.

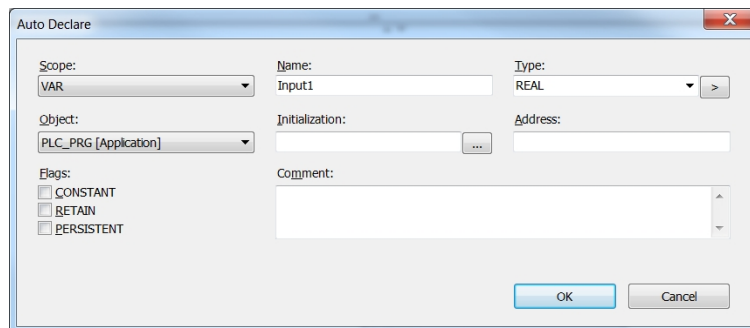

Select the Type from the drop down. In this example the type is a REAL value.

The flags CONSTANT, RETAIN and PERSISTANT are defined in the CODESYS Help. Note that RETAIN and PERSISTANT data is stored in an FRAM device, periodically (typically every 10s).

When the block has been entered it will appear under the 'VAR' list.

4.2.3 Wiring

Example: To connect the Input to an Output container so that its value appears in the output container. Drag and drop an 'Output' from the ToolBox and configure it in the same way as shown for Input1. Click on either the input or output and drag a wire from one to the other.

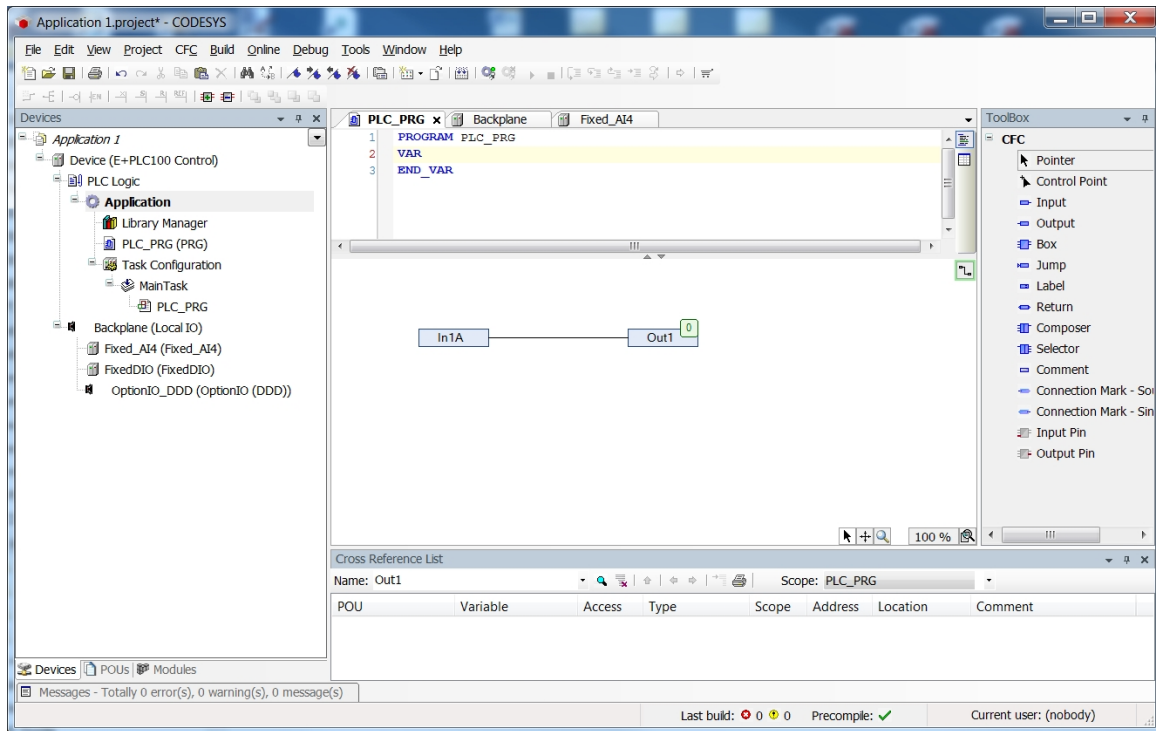

4.2.4 To Add a PID Control Block

A further strategy can be built using the items from the ToolBox.

The ToolBox contains a list of commonly used function blocks.

If the required block is not present it can be added from the library. For example, to add a control block, select 'Library Manager' from the list. Click 'Add library' and 'Select EPLC Control' and OK.

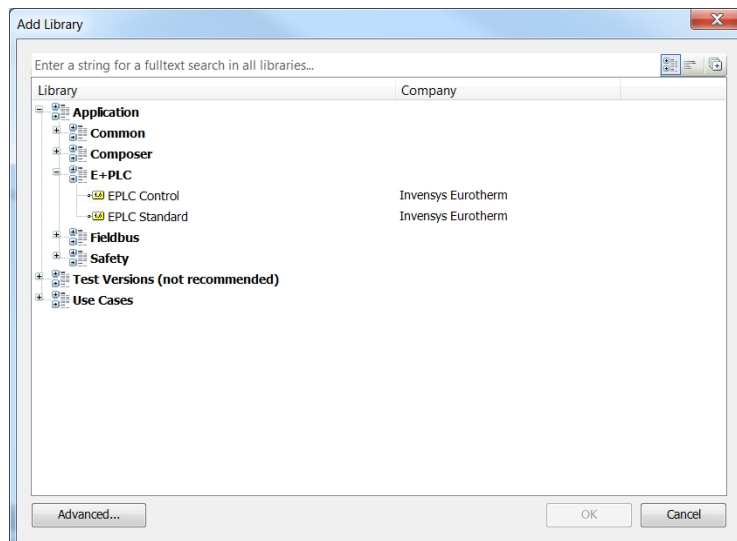

4.2.4.1 Example 1: To wire Input1 to the PID loop

Drag a 'Box' from the ToolBox. Name the box eg PID - a drop down is shown when you begin typing. When the block is declared it will appear in the VAR list.

Add a wire from the output of 'Input1' to the applicable input parameter of the PID block, e.g. the PV input 'rPV'.

Note the prefix:-

r means a reference source.

x is a boolean

e is an enumeration

rr is a reference source the value of which can be overridden depending upon the strategy. For example, a three term value may be overridden by auto tune

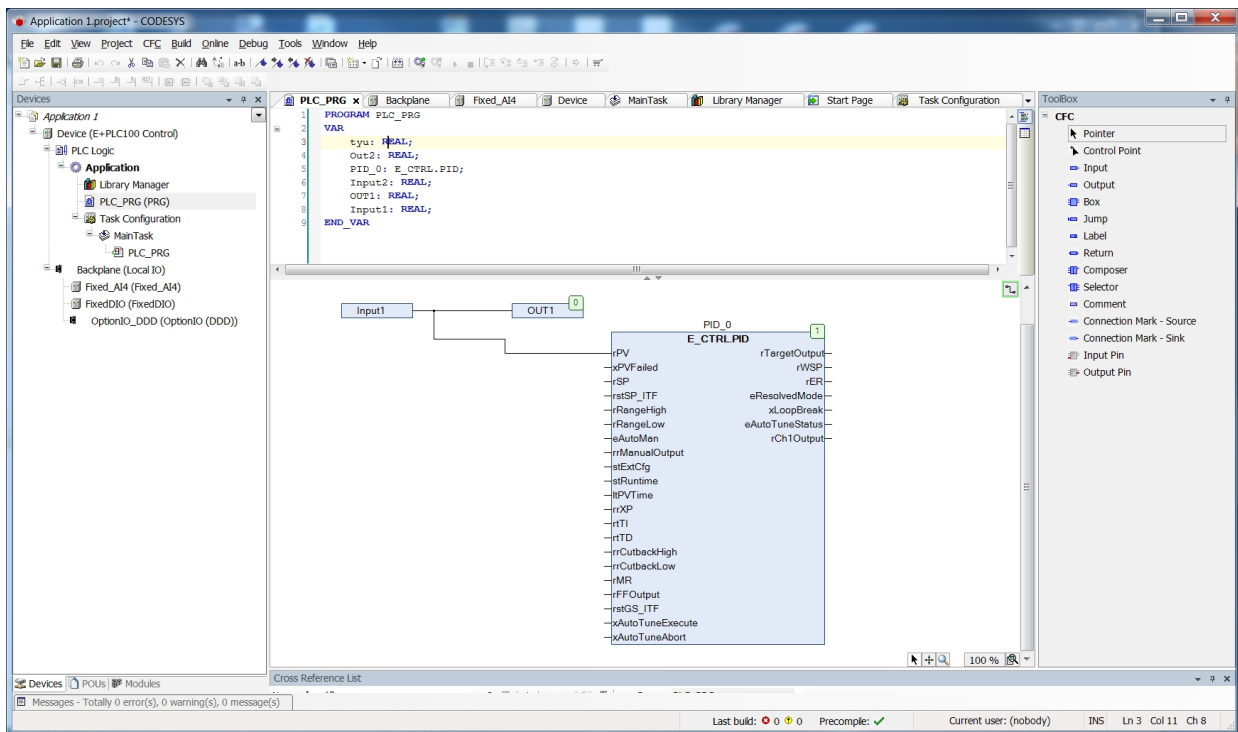

Note:

To reduce the number of I/O parameters, right click the block, select 'Pins' and 'Remove Unused pins'.

When complete select 'Build' from the menu.

Further information is available by accessing the Help library.

4.2.5 Example 2: Touch Screen Lock

A function block specific to E+PLC100 allows the touch screen to be locked. The strategy shown in the screen shot below shows the touch screen locked by a digital input being activated. The strategy could be expanded using inputs such as a timer to start a timed delay, for example.

A confirmation of the lock is produced by the function block TouchScreenLocked shown below connected to a digital output but which could equally produce a screen message or other functions.

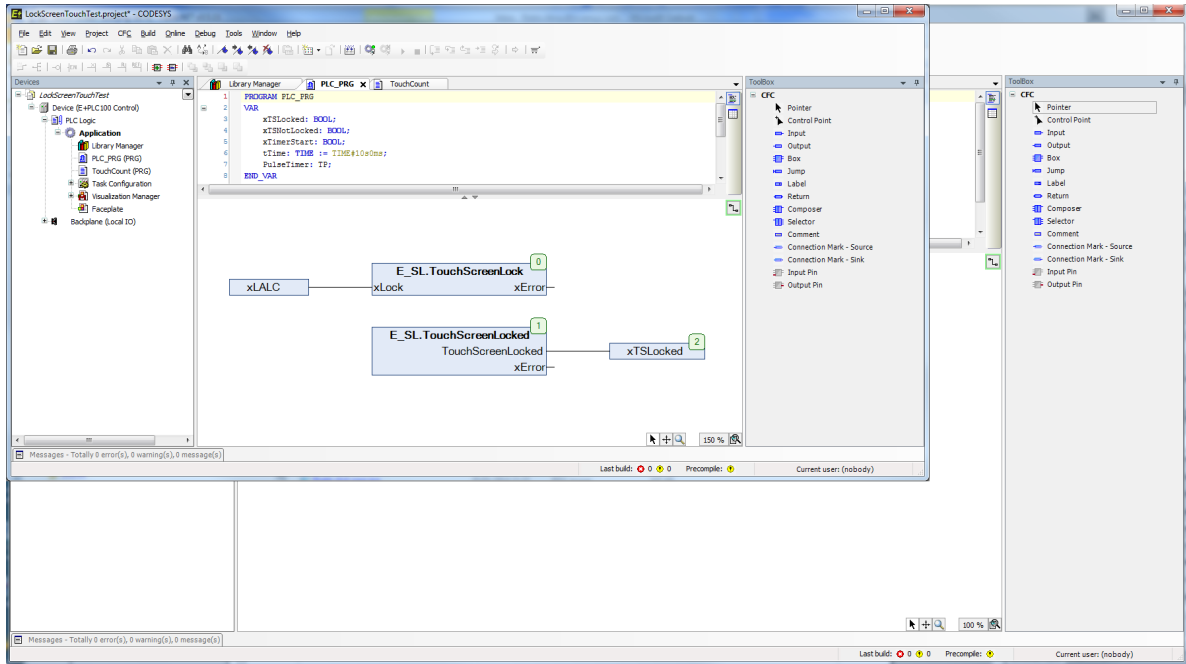

To produce the TouchScreenLock function block, Drag a 'Box' to the screen. Begin to type 'E_SL' (Eurotherm Screen Lock) and select this from the pop up. Then begin to type '.' and select 'TouchScreenLock'.

The 'TouchScreenLocked' confirmation function block is similarly produced.

These blocks are shown wired to Input and Output blocks as in the previous example.

Alternatively, it may be found more convenient to add the EPLC Screen Lock library from the Library Manager. The procedure is described in Section 4.2.4.

5 LOADING A NEW APPLICATION

As stated in section 3 it is necessary to clear the demonstration or any other application before loading a new one. The method for doing this is to perform a 'Reset origin device' operation in the CODESYS software. This is accessed from the CODESYS IDE file manager.

This will remove all application specific files, including the visualisation images.

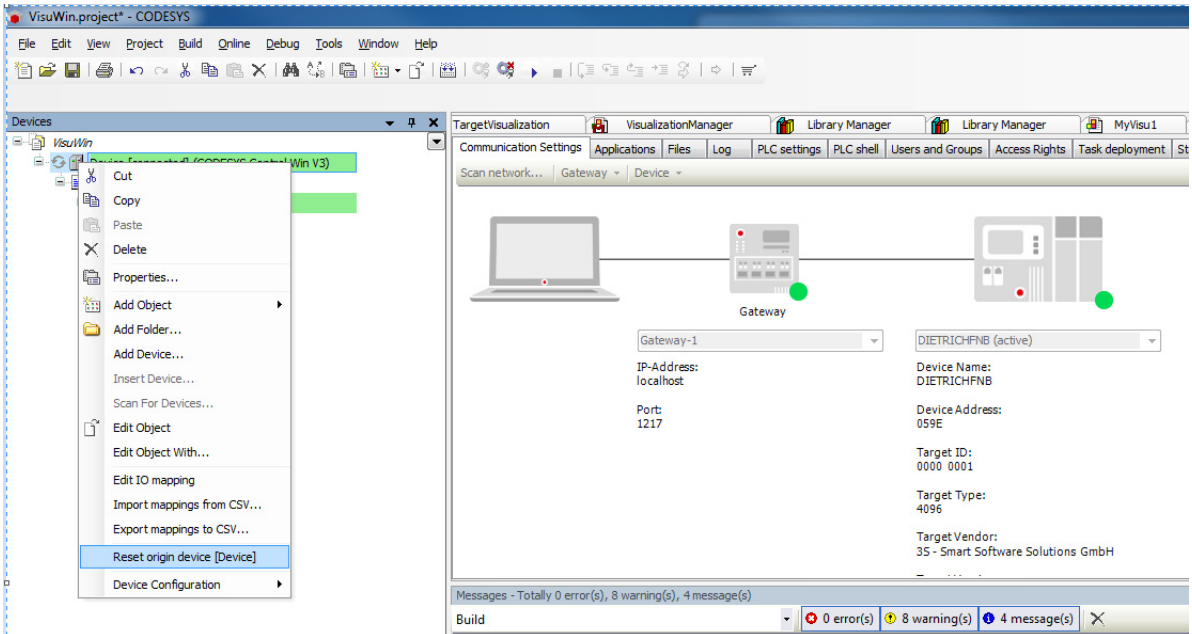

Note: In the current release it is not possible to access the application files via the CODESYS IDE file manager.

6 Accessing the CODESYS Online Help

The CODESYS software includes extensive online help.

To launch the CODESYS help, click on its Help menu:



The Online Help window is displayed.

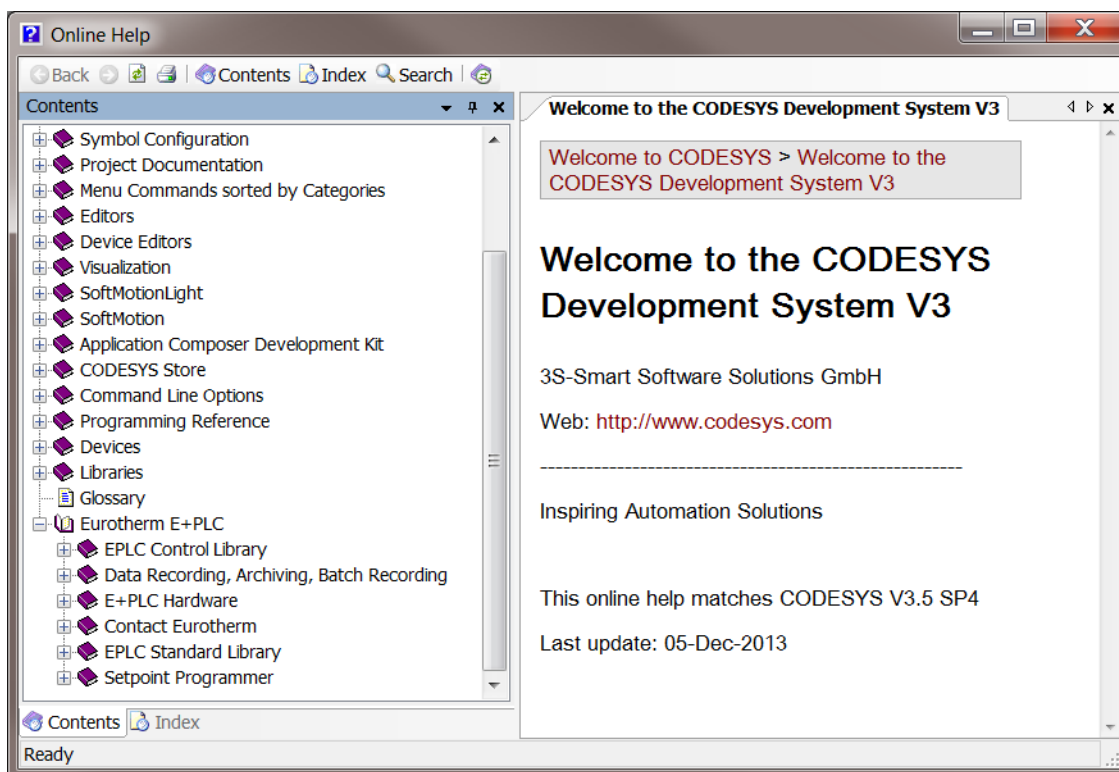

6.1 CODESYS Library Documentation

In addition to the CODESYS Online help, CODESYS libraries include their own documentation, with detailed information on the POU (Program Organisation Units) in the library (such as functions and function blocks). These can be viewed in the CODESYS editor windows themselves, for example, in the Library Manager shown below.

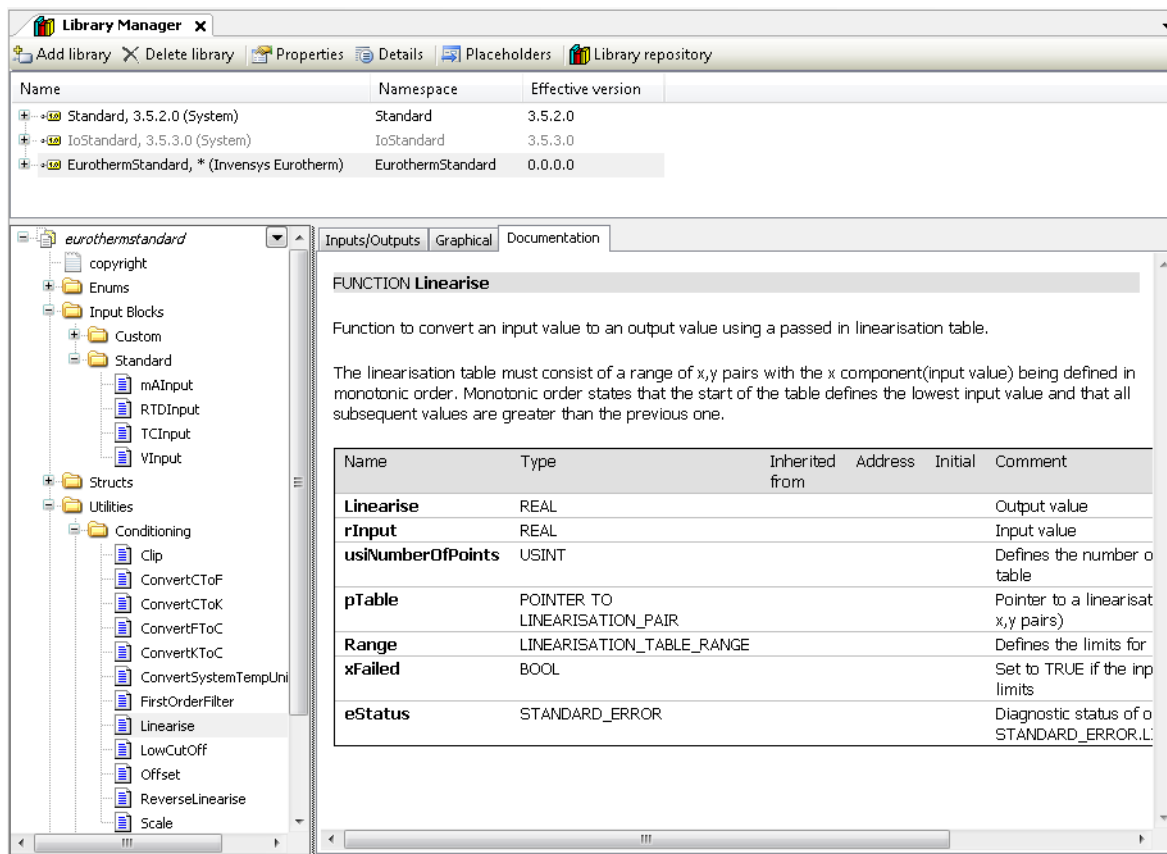

A subset of the same information is also displayed in a tooltip when using the mouse to hover over POU. To display information on a POU in the Online Help window, select the POU and press F1.

6.2 Online tutorials and 'How to' videos

A range of online tutorials and 'How to' videos for the E+PLC100 are available. These can be accessed through the web portal on the Start page displayed when CODESYS is first launched - see also Section 4.1.

Note: to access the online tutorials, the PC running the CODESYS software must have internet access.

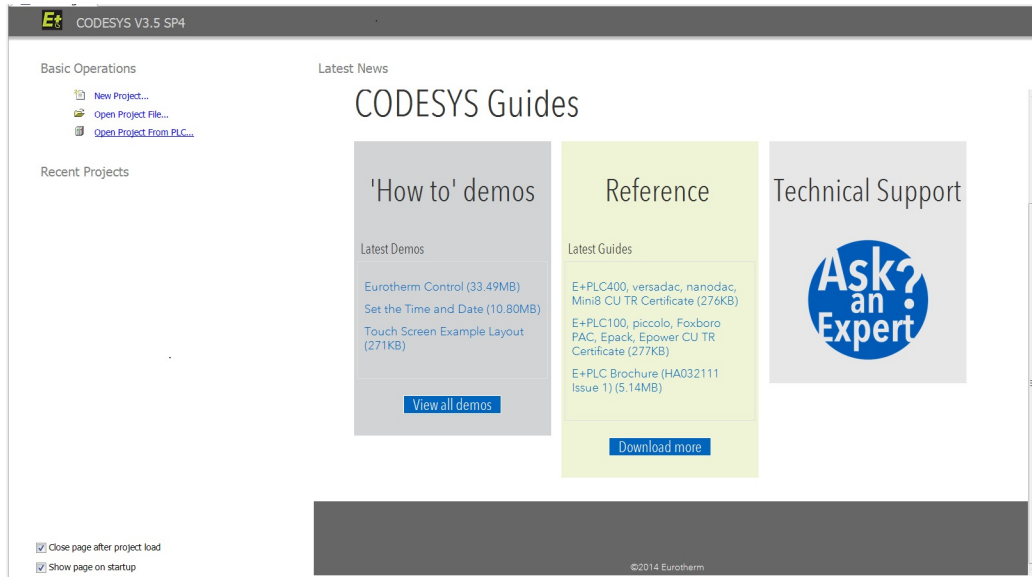

A Appendix A: TECHNICAL SPECIFICATION

A.1 INSTALLATION CATEGORY AND POLLUTION DEGREE

This product has been designed to conform to BS EN61010 installation category II and pollution degree 2, defined as follows:

Installation category II

The rated impulse voltage for equipment on nominal 230V mains is 2500V.

Pollution degree 2

Normally, only non-conductive pollution occurs. Occasionally, however, a temporary conductivity caused by condensation shall be expected.

A.2 SPECIFICATION

General

I/O types	Analogue i/p: Digital i/p: Digital (logic) o/p: Relay o/p: DC output:	Four Two Two maximum (dependant on build variant) Three maximum (dependant on build variant) Three maximum (dependant on build variant)
Memory Resources	12Mbytes 28Mbytes 64432bytes	for Application/Visualisation files for Data Recording history files for Retain/Persistent data

Environmental performance

Ambient temperature range	Operating: Storage:	0 to 55°C -20 to +70°C
Humidity range	Operating: Storage:	5% to 85% RH non condensing 5% to 85% RH non condensing
Protection	Front panel Behind panel: Shock/Vibration:	IP65 IP10 (International) To BS EN61131-2: section 4.2.1 (5 to 150 Hz. at 2g; 0.5 octave per min.)
Altitude:		<2000 metres
Atmosphere:		Not suitable for use in explosive or corrosive atmospheres
Electrical safety:		BS EN61010-1 (Installation category II; Pollution degree 2)

Electromagnetic compatibility

Emissions	Standard units: Low voltage option:	BS EN61326 Class B - Light industrial BS EN61326 Class A - Heavy industrial BS EN61326 Industrial
-----------	--	---

Immunity:

Other approvals and compliance details	General: PV input: RoHS	CE and cUL, EN61010 AMS2750 compliant EU; China BS61131-2:2007 - Section 6.3.3./6.3.4.
--	-------------------------------	---

Packaging:

Physical

Panel mounting:		1/4 DIN
Weight:	Instrument only:	0.44kg (15.52ozs)
Panel cut out dimension		92 x 92mm (both -0.0 +0.8) or 3.62 x 3.62" (both -0.00 +0.03")
Depth behind panel:		90 mm (3.54 in) excluding wiring
Operator interface		
Display:	Touchscreen	3.5" TFT colour display (320 pixels wide x 240 pixels high). Active touch screen size 320 X 288 pixels - refer to Appendix B.
Power requirements		
Supply voltage:	Standard: Low voltage:	100 to 230V ac $\pm 15\%$ at 48 to 62Hz 24V ac (+10% -15%) at 48 to 62Hz, or 24V dc (+20% -15%)
Power dissipation:		9W (max.)
Fuse type:		No internal fuse fitted
Interrupt protection:	Standard: Low voltage:	Holdup >20ms at 85V RMS supply voltage Holdup >20ms at 20.4V RMS supply voltage

Battery backup

Stored data:		Time, date
Replacement period:		Three years typical
Clock (real-time clock) data:	Support time: Temperature stability: RTC Ageing:	Minimum of 1 year with unit unpowered 0 to 55°C $\leq \pm 3.5$ ppm First year to 10 year $< \pm 5$ ppm Poly-carbonmonofluoride/lithium Eurotherm Part Number (PA260195)
Type:		

Caution: Battery may explode if mistreated. Do not recharge, disassemble or dispose of in fire.

Ethernet communications

Type:		10/100baseT Ethernet (IEEE802.3)
Protocols:		Modbus TCP/IP master/slave
Cable type:		Category 5
Maximum length:		100metres (110 yards)
Termination:		RJ45 Green LED illuminated = link connected; Amber LED flashing shows link activity

USB port

Number of ports:	One at rear of instrument
Standard:	USB1.1
Transmission speeds:	1.5Mbit/sec (low speed device)
Maximum current:	<100mA
Peripherals supported:	Memory stick (8GB max)
Update/Archive rates	
Sample rate (input/output):	8Hz
Trend update:	10Hz max.
Archive sample value:	Latest value at archive time
Display value:	Latest value at display update time

Option Boards

LLR (Logic, Logic, Relay)
 DDD (DC o/p, DC o/p, DC o/p)

Analogue Inputs

General

Number of Inputs:	Four
Input types:	dc Volts, dc mV, dc mA, mV, RTD (2-wire and 3-wire)
Input type mix:	Freely configurable
Sample rate:	8Hz (125ms)
Conversion method:	16 bit delta sigma
Input ranges:	See Table 1 and Table 2
Mains rejection (48 to 62Hz)	
	Series mode: > 95dB
	Common mode: >179dB
	Common mode voltage: 250V ac max.
Series mode voltage:	280mV at lowest range; 5V peak to peak at highest range
Input Impedance:	40mV, 80mV, 2V ranges > 100M Ω ; 62.5k Ω for input voltages > 5.6V 667k Ω for input ranges < 5.6V
Over-voltage protection	
	Continuous: \pm 30V RMS
	Transient (<1ms): \pm 200V pk-pk between terminals
Sensor break detection	Type: ac sensor break on each input giving quick response with no associated dc errors
	Recognition time: <3 seconds
	Minimum break resistance: 40mV, 80mV ranges: 5k Ω ; other ranges: 12.5k Ω
Shunt (mA inputs only):	1 Ω to 1K Ω mounted externally
additional error due to shunt:	0.1% of Input
Isolation:	
	Channel to Channel: 300V RMS or dc (Double insulation)
	Channel to common elec-tronics: 300V RMS or dc (Double insulation)
	Channel to ground: 300V RMS or dc (Double insulation)
Dielectric strength	Test: BS EN61010, 1 minute type test
	Channel to Channel: 2500V ac
	Channel to Ground: 1500V ac

Table 1: Voltage Input Ranges

Low Range	High Range	Resolution	Maximum error (Instrument at 25°C)	Temperature Performance
-40mV	40mv	1.9 μ V	4.6 μ V + 0.053% of reading	13ppm of input per °C
-80mV	80mV	3.2 μ V	7.5 μ V + 0.052% of reading	13ppm of input per °C
-2V	2V	82 μ V	420 μ V + 0.044% of reading	13ppm of input per °C
-3V	10V	500 μ V	1.5mV + 0.063% of reading	45ppm of input per °C

Resistance Input Ranges

Temperature scale:

ITS90

Types, ranges and accuracies:

See Table 3

Maximum source current:

200 μ A

Pt100 figures

Range:

0 to 400 Ω (-200 to +850 $^{\circ}$ C)

Resolution:

0.05 $^{\circ}$ C

Calibration error:

 $\pm 0.31^{\circ}$ C $\pm 0.023\%$ of measurement in $^{\circ}$ C at 25 $^{\circ}$ C ambient

Temperature coefficient:

 $\pm 0.01^{\circ}$ C/ $^{\circ}$ C ± 25 ppm/ $^{\circ}$ C measurement in $^{\circ}$ C from 25 $^{\circ}$ C ambient

Measurement noise:

0.05 $^{\circ}$ C peak-peak with 1.6s input filter

Linearity error:

0.0033% (best fit straight line)

Lead resistance:

0 to 22 Ω matched lead resistances

Bulb current:

200 μ A nominal**Table 2: Ohms (RTD) input ranges**

Low Range	High Range	Resolution	Maximum error (Instrument at 25 $^{\circ}$ C)	Temperature Performance
0 Ω	400 Ω	20m Ω	120m Ω + 0.023% of reading	25ppm of input per $^{\circ}$ C

Table 3: RTD type details

RTD Type	Overall range	Standard	Max. linearisation ($^{\circ}$ C)
Cu10	-20 to +400	General Electric Co.	0.02 $^{\circ}$ C
Cu53	-70 to +200	RC21-4-1966	0.01 $^{\circ}$ C
JPT100	-220 to +630	JIS C1604:1989	0.01 $^{\circ}$ C
Ni100	-60 to + 250	DIN43760:1987	0.01 $^{\circ}$ C
Ni120	-50 to +170	DIN43760:1987	0.01 $^{\circ}$ C
Pt100	-200 to + 850	IEC751	0.01 $^{\circ}$ C
Pt100A	-200 to + 600	Eurotherm Recorders SA	0.09 $^{\circ}$ C

Thermocouple Data

Temperature scale:

CJC

Types:

Remote CJC source:

Internal CJC error:

Internal CJC rejection ratio:

Upscale/downscale drive:

ITS90

Off, internal, external, remote.

Any input channel

<1°C max., with instrument at 25 °C

40:1 from 25°C

High, low or none independently

configurable for each channel's sensor break detection

See Table 4

Types, ranges and accuracies:

Table 4: Thermocouple types , ranges and accuracies			
T/C Type	Range (°C)	Standard	Max. linearisation error
B	0 to +1820	IEC584.1	0 to 400°C = 1.7°C 400 to 1820°C = 0.03°C
C	0 to +2300	Hoskins	0.12°C
D	0 to +2495	Hoskins	0.08°C
E	-270 to +1000	IEC584.1	0.03°C
G2	0 to + 2315	Hoskins	0.07°C
J	-210 to +1200	IEC584.1	0.02°C
K	-270 to +1372	IEC584.1	0.04°C
L	-200 to +900	DIN43710:1985 (to IPTS68)	0.02°C
N	-270 to +1300	IEC584.1	0.04°C
R	-50 to +1768	IEC584.1	0.04°C
S	-50 to +1768	IEC584.1	0.04°C
T	-270 to +400	IEC584.1	0.02°C
U	-200 to + 600	DIN43710:1985	0.08°C
NiMo/NiCo	-50 to + 1410	ASTM E1751-95	0.06°C
Platinel	0 to + 1370	Engelhard	0.02°C
Mi/NiMo	0 to + 1406	Ipsen	0.14°C
Pt20%Rh/Pt40%/Rh	0 to + 1888	ASTM E1751-95	0.07°C
Pt40%Rh			

Relay and Logic I/O

O/P1, O/P2 and O/P3 logic I/O and relay specification

Active (current on) current sourcing logic output (O/P1 or O/P2 only)

Voltage o/p across terminals:

+11V min.; +13V max.

Short circuit output current:

6mA min. (steady state); 44mA max. (switch current)

Inactive (current off) current sourcing logic output (O/P1 or O/P2 only)

Voltage o/p across terminals

0V (min.); 300mV (max.)

Output source leakage current into short circuit:

0µA (min.); 100µA (max.)

Active (current on) contact closure sourcing logic input (O/P1 only)

Input current

Input at 12V:

0mA (min.); 44mA (max.)

Input at 0V:

6mA min. (steady state); 44mA max. (switch current)

Open circuit input voltage:

11V (min.); 13V (max.)

Open circuit (inactive) resistance:

>500Ω (min.)

Closed circuit (active) resistance:

0Ω (min.); 150Ω (max.)

Relay Contacts

Contact switching power (resistive):

Max. 2A at 230V RMS ±15%

Min. 100mA at 12V

2A

Current through terminals:

General

Isolation

300V RMS or dc (double insulation) relays to common electronics

Digital Inputs

Dig InA and Dig InB contact closure logic input

Contact closure

Short circuit sensing current (source):

5.5mA (min.); 6.5mA (max.)

Open circuit (inactive) resistance:

>600Ω (min.)

Closed circuit (active) resistance:

0Ω (min.); 300Ω (max.)

DC Output (Option)

O/P1, O/P2, O/P3 DC analogue outputs

Current outputs (O/P1, O/P2 and O/P3)

Output ranges:

Configurable within 0 to 20mA

Load resistance:

500Ω max.

Calibration accuracy:

<±100µA ±1% of reading

Voltage outputs (OP3 only)

Output ranges:

Configurable within 0-10V

Load resistance:

500Ω min.

Calibration accuracy:

<±50mV ±1% of reading

General

Isolation:

300V RMS or dc (double insulated) relays to common electronics

Resolution:

>11 bits

Thermal drift:

<100ppm/°C

B Appendix B: DISPLAY AND ACTIVE TOUCH SCREEN DIMENSIONS

This section shows the dimensions in pixels for the active touch screen area. It includes the display area and the button positions.

The size of the image and, therefore, the size that the visualisation is to be set is 320 x 288 pixels.

The button size and their positions from the top left hand corner are shown in the table below:

Button Size: 48 x 32 pixels	x	y
f1	1	255
f2	91	255
f3	182	255
f4	271	255

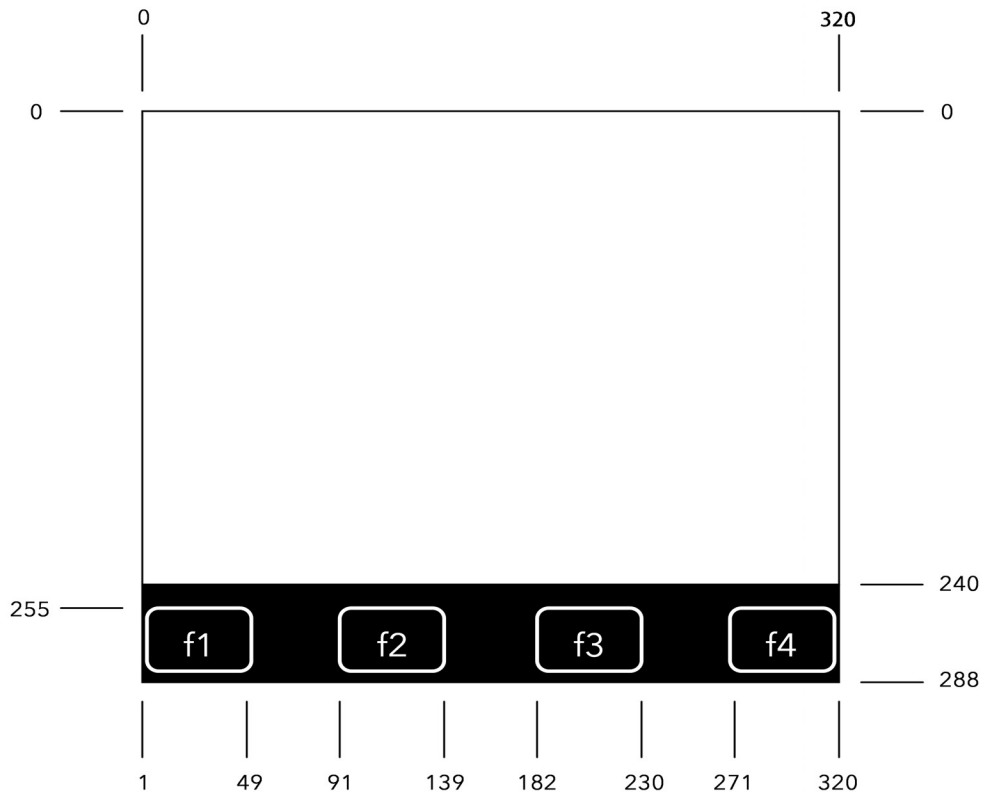

Notes:

A touch in the same location for more than 10 seconds will be filtered out.

It is recommended that the active elements are greater in size than the actual function keys.

The faceplate image is available from the E+PLC installed location, typically:

C:\Program Files (x86)\Eurotherm\E+PLC\E+PLC100\Images'

C Appendix C: HINTS AND TIPS

This section provides a place to document miscellaneous useful information.

C.1 Recovery from excessive CPU loading

It is possible for an application to be developed that consumes all available CPU bandwidth which would prevent other lower priority tasks from running, this could include the network task resulting in the loss of network connection or not being able to make a network connection. To recover from this situation with a project that has been loaded and is running which contains such a task, but a boot application has not been created, simply power-cycle the device as the application is not retained. However, to recover from this situation with a project that has been loaded and is running which contains such a task AND a boot application has been created, copy the files located in the E+PLC100 Recovery directory (typically C:\Program Files (x86)\Eurotherm\E+PLC\E+PLC100\Recovery) onto the root of a USB memory stick, insert the memory stick into the E+PLC100 device and power-cycle - this will result in the removal of the offending application.

C.2 Recovery from invalid/forgotten network settings

The network settings used by the E+PLC100 are contained in a network.ini file stored in the /startup drive on the device. In the event of these network settings being invalid for the network, or being forgotten, a connection can be made using the network settings contained in a network.ini file located on the root of a connected USB memory stick. This would allow an application to be developed to modify the internally stored network.ini file with the correct network settings. It should be noted that when the USB memory stick is removed and the device power-cycled, the device will use the network settings from the internally stored network.ini file.

C.3 Recovery in the event of a fully built up firewall

It is possible for a firewall rule file to be created that blocks all incoming network traffic which would prevent the device ever being connected. If a device contains such a firewall configuration file, it is possible to open default network ports used by CODESYS by connecting a USB memory stick that contains a file called fw4.default in its root directory and power-cycling the device. It should be noted that when the USB memory stick is removed and the device power-cycled, the device will use the internally stored firewall rule file fw4.cfg (stored in the /startup drive).

The default firewall permits the following:

- All TCP and UDP outbound traffic and their associated inbound responses (allowing Modbus master and FTP archiving communications)
- TCP and UDP inbound traffic from any port to port 53 (allowing DNS communications)
- ICMP traffic with rate limiting conditions (allowing PINGs and other Internet Control messages)
- UDP incoming traffic from any port to ports 1740 to 1743, and TCP incoming traffic from any port to port 11740 (allowing CODESYS IDE and gateway network scanner communications)
- UDP incoming traffic from any port to ports 1210, 1211, 1217 (allowing CODESYS gateway to PLC communications)

It should be noted that the default firewall does not permit the following, and additional firewall rules are required:

- Modbus slave communications (pass in on emac0 proto tcp from any to any port = 502)
- HTML communications (pass in on emac0 proto tcp from any to any port = 8080)
- SNTP communications (pass in on emac0 proto udp from any to any port = 123)

C.4 Line Voltage Measurement for Power Feed Forward Control

The GetPSULineVoltage function from the ECmpPSU library can be utilised to get the line voltage for the E_CTRL.LOOP_RUNTIME.rVLine input.

C.5 Watchdog functionality

Hardware watchdog - The E+PLC100 Controller incorporates a hardware watchdog function that will trigger a device reset if an IO system health check fails.

For further information, refer to the CODESYS Help.

C.6 Ensure all images are downloaded

To ensure all images in an image pool are downloaded, verify that the 'Download only used images' attribute is unset as shown below:

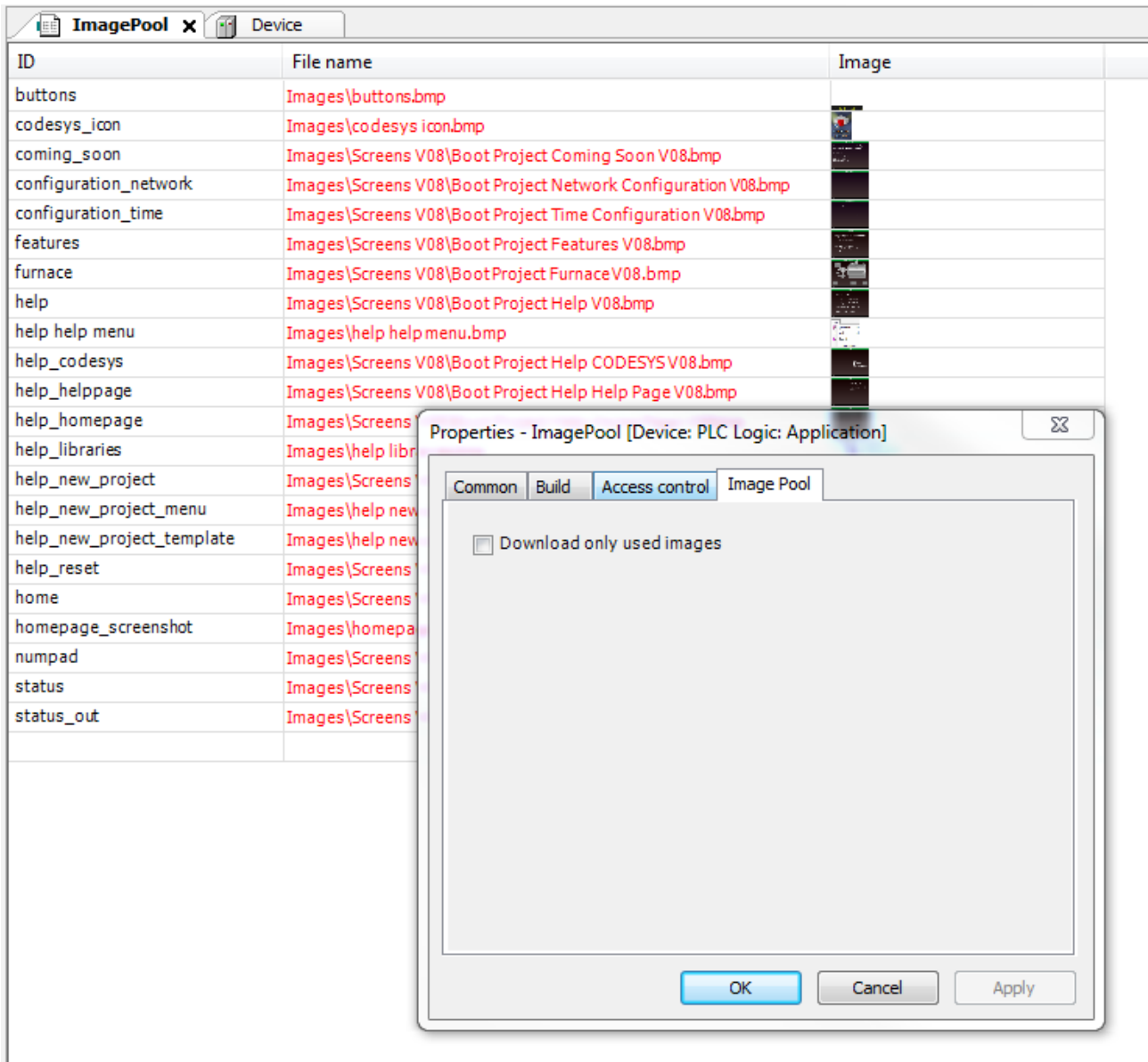

Notes:

E+PLC100 supports 24-bit bitmap images, however, they will be converted down to 16-bit bitmap images to be displayed on the target instrument and therefore image degradation may occur.

E+PLC100 does not support JPG images on the target instrument in this release.

International sales and support
Eurotherm:

www.eurotherm.com

Contact Information

Eurotherm Head Office
Faraday Close,
Durrington,
Worthing, West Sussex,
BN13 3PL

Sales Enquiries

T +44 1903 695888
F +44 845 130 9936

General Enquiries

T +39 031 975 111
F +39 031 977 512

Worldwide Offices

www.eurotherm.com/global



Scan for local contacts

© 2014 Eurotherm Limited

Invensys, Eurotherm, the Eurotherm logo, Chessell, EurothermSuite, Mini8, Eycon, Eyris, EPower, EPack nanodac, piccolo, versadac, optivis, Foxboro, and Wonderware are trademarks of Invensys plc, its subsidiaries and affiliates. All other brands may be trademarks of their respective owners.

All rights are strictly reserved. No part of this document may be reproduced, modified or transmitted in any form by any means, neither may it be stored in a retrieval system other than for the purpose to act as an aid in operating the equipment to which the document relates, without the prior written permission of Invensys Eurotherm Limited.

Eurotherm Limited pursues a policy of continuous development and product improvement. The specifications in this document may therefore be changed without notice. The information in this document is given in good faith, but is intended for guidance only.